

RULES FOR THE SURVEY AND CONSTRUCTION OF STEEL SHIPS

CONTENTS

Part CSR-T COMMON STRUCTURAL RULES FOR DOUBLE HULL OIL TANKERS

Section 1 INTRODUCTION

1. Introduction to Common Structural Rules for Oil Tankers	1
1.1 General	1
1.2 Application of the Society's Rules	1
1.3 Guidance on Rule Structure	1

Section 2 RULE PRINCIPLES

1. Introduction	4
1.1 Rule Principles	4
2. General Assumptions	5
2.1 General	5
3. Design Basis	6
3.1 General	6
4. Design Principles	10
4.1 Overall Principles	10
4.2 Loads	10
4.3 Structural Capacity Assessment	13
4.4 Materials and Welding	15
4.5 Assessment/Acceptance Criteria	15
4.6 Principle of Safety Equivalence	16
5. Application of Principles	17
5.1 Overview of the Application of Principles	17
5.2 Structural Design Process	17
5.3 Minimum Requirements	19
5.4 Load-capacity Based Requirements	19
5.5 Materials	23
5.6 Application of Rule Requirements	23

Section 3 RULE APPLICATION

1. Notations	25
1.1 Notations	25
2. Documentation, Plans and Data Requirements	26
2.1 Documentation and Data Requirements	26
2.2 Submission of Plans and Supporting Calculations	26
3. Scope of Approval	28
3.1 General	28
3.2 Classification	28
4. Equivalence Procedure	29
4.1 General	29
5. Calculation and Evaluation of Scantling Requirements	30
5.1 Determination of Scantling Requirements for Plates	30
5.2 Determination of Scantlings of Stiffeners	33

5.3	Calculation and Evaluation of Scantling Requirements for Primary Support Members	36
5.4	Rounding of Calculated Thickness	37

Section 4 BASIC INFORMATION

1. Definitions	38
1.1 Principal Particulars	38
1.2 Position 1 and Position 2	39
1.3 Type 'A' and Type 'B' Freeboard Ships	40
1.4 Coordinate System	40
1.5 Naming Convention	41
1.6 Symbols	43
1.7 Units	43
1.8 Glossary	44
2. Structural Idealisation	49
2.1 Definition of Span	49
2.2 Definition of Spacing and Supported Breadth	59
2.3 Effective Breadth of Plating	59
2.4 Geometrical Properties of Local Support Members	63
2.5 Geometrical Properties of Primary Support Members	69
2.6 Geometrical Properties of the Hull Girder Cross-Section	71
3. Structure Design Details	77
3.1 Standard Construction Details	77
3.2 Termination of Local Support Members	77
3.3 Termination of Primary Support Members	82
3.4 Intersections of Continuous Local Support Members and Primary Support Members	83
3.5 Openings	91
3.6 Local Reinforcement	92
3.7 Fatigue Strength	93

Section 5 STRUCTURAL ARRANGEMENT

1. General	94
1.1 Introduction	94
2. Watertight Subdivision	95
2.1 Watertight Bulkhead Arrangement	95
2.2 Position of Collision Bulkhead	95
2.3 Position of Aft Peak Bulkhead	95
3. Double Hull Arrangement	96
3.1 General	96
3.2 Double Bottom	96
3.3 Double Side	96
4. Separation of Spaces	97
4.1 Separation of Cargo Tanks	97
4.2 Cofferdam Spaces	97
5. Access Arrangements	98
5.1 Access Into and Within Spaces in, and Forward of, the Cargo Tank Region	98

Section 6 MATERIALS AND WELDING

1. Steel Grades	99
1.1 Hull Structural Steel	99

1.2 Application of Steel Materials	99
1.3 Aluminium Alloys	102
2. Corrosion Protection Including Coatings	103
2.1 Hull Protection	103
3. Corrosion Additions	105
3.1 General	105
3.2 Local Corrosion Additions	105
3.3 Application of Corrosion Additions	108
4. Fabrication	110
4.1 General	110
4.2 Cold Forming	111
4.3 Hot Forming	111
4.4 Welding	112
5. Weld Design and Dimensions	113
5.1 General	113
5.2 Butt Joints	113
5.3 Tee or Cross Joints	114
5.4 Lapped Joints	117
5.5 Slot Welds	118
5.6 Stud Welds	118
5.7 Determination of the Size of Welds	118
5.8 Weld for Structures Subject to High Tensile Stresses	122
5.9 Reduced Weld Size	122
5.10 End Connections of Pillars and Cross Ties	123
5.11 Alternatives	123

Section 7 LOADS

1. Introduction	129
1.1 General	129
1.2 Definitions	129
2. Static Load Components	131
2.1 Static Hull Girder Loads	131
2.2 Local Static Loads	134
3. Dynamic Load Components	138
3.1 General	138
3.2 Motions	139
3.3 Ship Accelerations	140
3.4 Dynamic Hull Girder Loads	142
3.5 Dynamic Local Loads	145
4. Sloshing and Impact Loads	155
4.1 General	155
4.2 Sloshing Pressure in Tanks	155
4.3 Bottom Slamming Loads	161
4.4 Bow Impact Loads	163
5. Accidental Loads	165
5.1 Flooded Condition	165
6. Combination of Loads	166
6.1 General	166
6.2 Design Load Combination	166
6.3 Application of Dynamic Loads	167
6.4 Dynamic Load Cases and Dynamic Load Combination Factors for Strength Assessment	178

6.5 Dynamic Load Cases and Dynamic Load Combination for Scantling Requirements	178
--	-----

Section 8 SCANTLING REQUIREMENTS

1. Longitudinal Strength	183
1.1 Loading Guidance	183
1.2 Hull Girder Bending Strength	186
1.3 Hull Girder Shear Strength	189
1.4 Hull Girder Buckling Strength	199
1.5 Hull Girder Fatigue Strength	201
1.6 Tapering and Structural Continuity of Longitudinal Hull Girder Elements	202
2. Cargo Tank Region	205
2.1 General	205
2.2 Hull Envelope Plating	207
2.3 Hull Envelope Framing	209
2.4 Inner Bottom	209
2.5 Bulkheads	209
2.6 Primary Support Members	224
3. Forward of the Forward Cargo Tank	244
3.1 General	244
3.2 Bottom Structure	245
3.3 Side Structure	246
3.4 Deck Structure	247
3.5 Tank Bulkheads	248
3.6 Watertight Boundaries	248
3.7 Superstructure	249
3.8 Miscellaneous Structures	249
3.9 Scantling Requirements	250
4. Machinery Space	256
4.1 General	256
4.2 Bottom Structure	258
4.3 Side Structure	258
4.4 Deck Structure	259
4.5 Machinery Foundations	260
4.6 Tank Bulkheads	261
4.7 Watertight Boundaries	262
4.8 Scantling Requirements	262
5. Aft End	266
5.1 General	266
5.2 Bottom Structure	267
5.3 Shell Structure	269
5.4 Deck Structure	270
5.5 Tank Bulkheads	271
5.6 Watertight Boundaries	271
5.7 Miscellaneous Structures	272
6. Evaluation of Structure for Sloshing and Impact Loads	273
6.1 General	273
6.2 Sloshing in Tanks	273
6.3 Bottom Slamming	279
6.4 Bow Impact	284
7. Application of Scantling Requirements to Other Structure	289
7.1 General	289

7.2 Scantling Requirements	289
----------------------------------	-----

Section 9 DESIGN VERIFICATION

1. Hull Girder Ultimate Strength	296
1.1 General	296
1.2 Rule Criteria	296
1.3 Hull Girder Bending Moment Capacity	296
1.4 Partial Safety Factors	296
2. Strength Assessment (FEM)	298
2.1 General	298
2.2 Cargo Tank Structural Strength Analysis	300
2.3 Local Fine Mesh Structural Strength Analysis	303
2.4 Application of Scantlings in Cargo Tank Region	305
3. Fatigue Strength	309
3.1 Fatigue Evaluation	309
3.2 Fatigue Criteria	309
3.3 Locations to Apply	310
3.4 Fatigue Assessment Methods	310

Section 10 BUCKLING AND ULTIMATE STRENGTH

1. General	312
1.1 Strength Criteria	312
2. Stiffness and Proportions	313
2.1 Structural Elements	313
2.2 Plates and Local Support Members	313
2.3 Primary Support Members	314
2.4 Other Structure	316
3. Prescriptive Buckling Requirements	319
3.1 General	319
3.2 Buckling of Plates	319
3.3 Buckling of Stiffeners	323
3.4 Primary Support Members	327
3.5 Other Structures	329
4. Advanced Buckling Analyses	332
4.1 General	332

Section 11 GENERAL REQUIREMENTS

1. Hull Openings and Closing Arrangements	333
1.1 Shell and Deck Openings	333
1.2 Ventilators	337
1.3 Air Pipes	339
1.4 Deck Houses and Companionways	341
1.5 Scuppers, Inlets and Discharges	347
2. Crew Protection	350
2.1 Bulwarks and Guardrails	350
2.2 Tank Access	351
2.3 Bow Access	351
3. Support Structure and Structural Appendages	354
3.1 Support Structure for Deck Equipment	354

3.2 Docking	363
3.3 Bilge Keels	363
4. Equipment	368
4.1 Equipment Number Calculation	368
4.2 Anchors and Mooring Equipment	369
4.3 Emergency Towing	377
5. Testing Procedures	378
5.1 Tank Testing	378

Section 12 SHIP IN OPERATION RENEWAL CRITERIA

1. Allowable Thickness Diminution for Hull Structure	382
1.1 General	382
1.2 Assessment of Thickness Measurements	382
1.3 Categories of Corrosion	383
1.4 Renewal Criteria of Local Structure for General Corrosion	385
1.5 Renewal Criteria of Hull Girder Sectional Properties for General Corrosion	387
1.6 Allowable Material Diminution for Pitting, Grooving and Edge Corrosion	387

Appendix A HULL GIRDER ULTIMATE STRENGTH

1. General	389
1.1 Definitions	389
1.2 Application	389
1.3 Assumptions	390
1.4 Alternative Methods	390
2. Calculation of Hull Girder Ultimate Capacity	391
2.1 Single Step Ultimate Capacity Method	391
2.2 Simplified Method Based on an Incremental-iterative Approach	392
2.3 Stress-strain Curves σ - ϵ (or Load-end Shortening Curves)	396
3. Alternative Methods	402
3.1 General	402
3.2 Methods	402

Appendix B STRUCTURAL STRENGTH ASSESSMENT

1. General	403
1.1 Application	403
1.2 Symbols, Units and Definitions	404
2. Cargo Tank Structural Strength Analysis	406
2.1 Assessment	406
2.2 Structural Modelling	406
2.3 Loading Conditions	414
2.4 Application of Loads	420
2.5 Procedure to Adjust Hull Girder Shear Forces and Bending Moments	425
2.6 Boundary Conditions	433
2.7 Result Evaluation	436
3. Local Fine Mesh Structural Strength Analysis	439
3.1 General	439
3.2 Structural Modelling	448
3.3. Loading Conditions	461
3.4 Application of Loads and Boundary Conditions	461

3.5	Result Evaluation and Acceptance Criteria	461
4.	Evaluation of Hot Spot Stress for Fatigue Analysis	463
4.1	Application	463
4.2	Structural Modelling	463
4.3	Loading Conditions	467
4.4	Boundary Conditions	469
4.5	Result Evaluation	469

Appendix C FATIGUE STRENGTH ASSESSMENT

1.	Nominal Stress Approach	471
1.1	General	471
1.2	Corrosion Model	471
1.3	Loads	471
1.4	Fatigue Damage Calculation	473
1.5	Classification of Structural Details	490
1.6	Other Details	501
2.	Hot Spot Stress (FE Based) Approach	503
2.1	General	503
2.2.	Corrosion Model	503
2.3	Loads	503
2.4.	Fatigue Damage Calculation	503
2.5	Detail Design Standard	505

Appendix D BUCKLING STRENGTH ASSESSMENT

1.	Advanced Buckling Analysis	511
1.1	General	511
2.	Advanced Buckling Analysis Method	513
2.1	General	513
3.	Application and Structural Modelling Principles	515
3.1	General	515
4.	Assessment Criteria	517
4.1	General	517
4.2	Utilisation Factors	517
5.	Strength Assessment (FEM) – Buckling Procedure	519
5.1	General	519
5.2	Structural Modelling and Capacity Assessment Method	519
5.3	Load Application	526
5.4.	Limitations of the Advanced Buckling Assessment Method	527
6.	Ultimate Hull Girder Strength Assessment	528
6.1	General	528
6.2	Load Application	528
6.3	Structural Modelling and Buckling Assessment	528

RULES FOR THE SURVEY AND CONSTRUCTION OF STEEL SHIPS

Part CSR-T COMMON STRUCTURAL RULES FOR DOUBLE HULL OIL TANKERS

Section 1 INTRODUCTION

1. Introduction to Common Structural Rules for Oil Tankers

1.1 General

1.1.1 Applicability

1.1.1.1 This Part apply to double hull oil tankers of 150m length, L_{CSR-T} , and upward classed with the Society and contracted for construction⁽¹⁾ on or after 1 April 2006 but before 1 July 2015. The definition of the rule length, L_{CSR-T} , is given in **Section 4/1.1.1.1**.

1.1.1.2 Generally, for double hull tankers of less than 150m in length, L_{CSR-T} , the Rules of the Society are to be applied.

1.1.1.3 Ships contracted for construction before the effective date of this Part are to comply with the Rules of the Society.

Note

The “contracted for construction” date means the date on which the contract to build the vessel is signed between the prospective owner and the shipbuilder. For further details regarding the date of “contracted for construction”, see **IACS Procedural Requirement (PR) No. 29**.

1.2 Application of the Society’s Rules

1.2.1 Regions of the ship which this Part does not cover

1.2.1.1 For regions of the structure which this Part does not cover, the relevant requirements of the Society’s Rules are to be applied.

1.3 Guidance on Rule Structure

1.3.1 Framework

1.3.1.1 This Part is structured in Sections giving instructions for detailed application and requirements which are applied in order to satisfy the Rule objectives. The acceptable procedures for the structural analysis required by this Part are given in the Appendices.

1.3.2 Numbering and cross-references

1.3.2.1 The system for numbering of Sections and Sub-Sections is given in **Table 1.1.1**.

Table 1.1.1 Section Numbering

Order	Levels	Example
1	Section name (displayed in the header)	SECTION 1 – INTRODUCTION
2	Sub-Section	1 INTRODUCTION TO THE COMMON STRUCTURAL...
3	Sub-Section 2	1.1 General
4	Sub-Section 3	1.1.1 Development of the rules
5	Paragraph number	1.1.1.1 An important part of the classification process is the development of rule...

1.3.2.2 The system for the numbering of Tables and Figures is given in **Table 1.1.2**.

Table 1.1.2 Numbering of Tables and Figures

Table location in document	Example of numbering
Section 5, Sub-Section 1, 2nd table in sub-section	Table 5.1.2
Section 1, Sub-Section 12, 5th table in sub-section	Table 1.12.5
Section 10, Sub-Section 4, 3rd table in sub-section	Table 10.4.3
Figure location in document	
Section 5, Sub-Section 1, 2nd figure in sub-section	Fig. 5.1.2
Section 1, Sub-Section 12, 5th figure in sub-section	Fig. 1.12.5
Section 10, Sub-Section 4, 3rd figure in sub-section	Fig. 10.4.3

1.3.2.3 Cross-references are given in **bold** throughout the document.

1.3.2.4 Cross-references within a Section (local) are represented as a Sub-Section or Paragraph number, e.g. **4.2** or **4.2.1.1**. See **Table 1.1.3**.

1.3.2.5 Cross-references outside a Section (global) are represented as Section no./Sub-Section or Paragraph number, e.g. **Section 4/2.1.1.3**. See **Table 1.1.3**.

Table 1.1.3 How Cross-References are Applied

Location of reference	Example of cross-reference	
<i>Local (within a Section)</i>		
Text in Sub-Section 4.2	See 4.2	in 4.2
Text in Sub-Section 6.2.2	See 6.2.2	in 6.2.2
Text in Paragraph 5.1.2.1	See 5.1.2.1	in 5.1.2.1
<i>Global (outside a section)</i>		
Text in Section 6, Sub-Section 4.2	Section 6/4.2	
Text in Section 6, Sub-Section 6.2.2	Section 6/6.2.2	
Text in Section 6, Paragraph 5.1.2.1	Section 6/5.1.2.1	

1.3.3 General organization of the Rules

1.3.3.1 The general organization of the Rules is shown in **Fig. 1.1.1**.

Fig .1.1.1 Schematic Layout of this Part

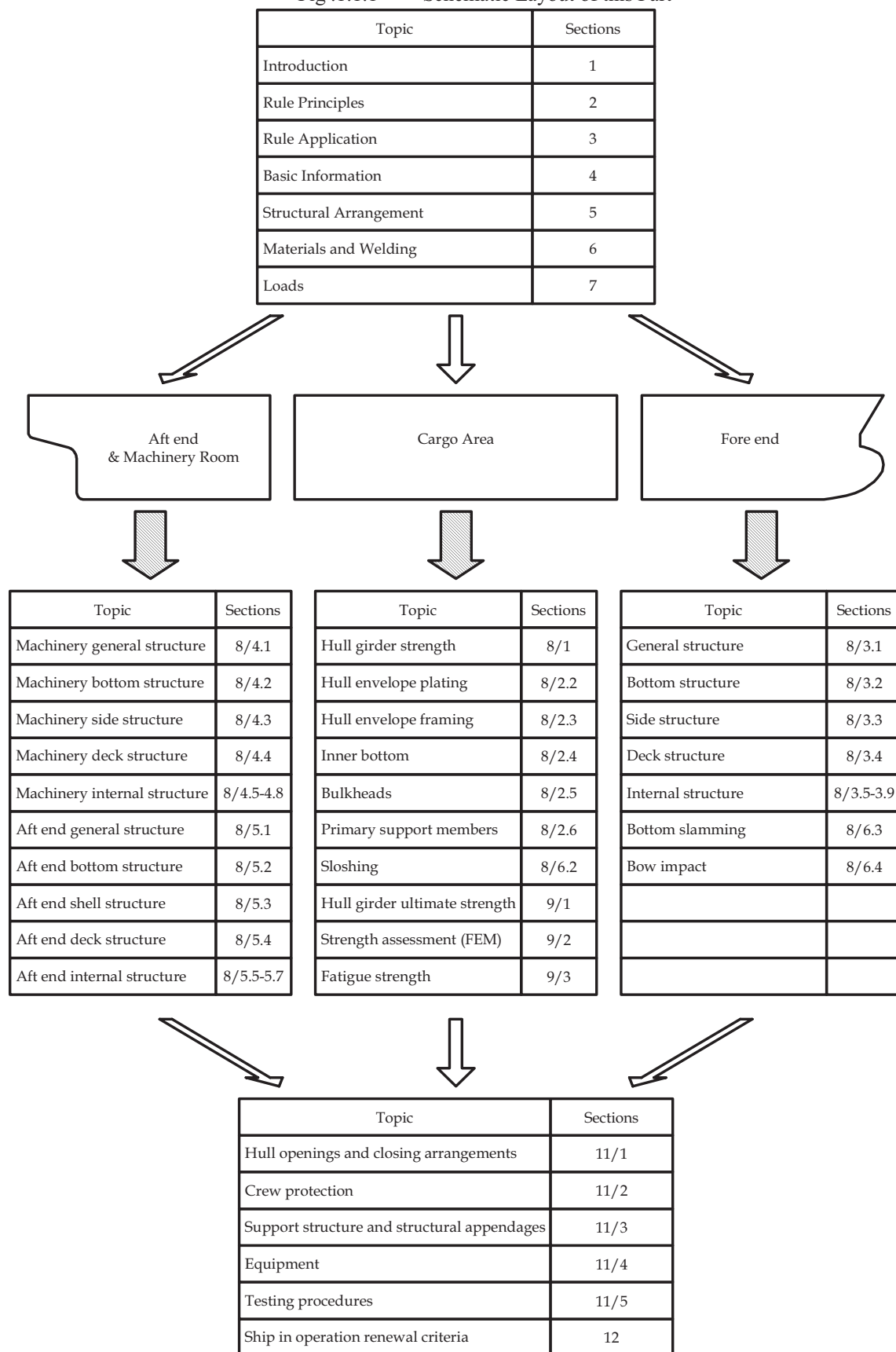

Section 2 RULE PRINCIPLES

1. Introduction

1.1 Rule Principles

1.1.1 Rule objectives

1.1.1.1 The objectives of the Rules are to establish requirements to reduce the risks of structural failure in order to help improve the safety of life, environment and property and to provide adequate durability of the hull structure for the design life.

1.1.2 General

1.1.2.1 The sub-sections contain:

- (a) the General Assumptions; pertaining to the design, construction and operation of the ship and gives information on the responsibilities of Classification Societies, builders and owners
- (b) the Design Basis; which specifies the premises that the design principles of the Rules are based on, in terms of design parameters and assumptions about the ship operation
- (c) the Design Principles; which define the fundamental principles used for the structural requirements in the Rules with respect to loads, structural capacity and assessment criteria
- (d) the Application of the Design Principles; which describes how the design principles and methods are applied and what criteria are used to demonstrate that the structure meets the objective.

2. General Assumptions

2.1 General

2.1.1 International and national regulations

2.1.1.1 Ships are to be designed, constructed and operated in compliance with the regulatory framework prescribed internationally by the International Maritime Organisation and implemented by National Administrations.

2.1.1.2 The Rules are based on the assumptions that all applicable statutory requirements are complied with.

2.1.1.3 The Rules incorporate the IACS unified requirements as shown in **Table 2.2.1**.

2.1.2 Classification Societies

2.1.2.1 Classification Societies develop and publish the standards for the hull structure and essential engineering systems. Classification Societies verify compliance with the classification requirements and the applicable international regulations when authorised by a National Administration during design, construction and operation of a ship.

Table 2.2.1 IACS Unified Requirements Applicable to Oil Tankers

Number	Title
A1	<i>Equipment</i>
A2	<i>Shipboard fittings and supporting hull structures associated with towing and mooring on conventional vessels</i>
S1	<i>Requirements for Loading Conditions, Loading Manuals and Loading Instruments</i>
S2	<i>Definitions of ship's length L_{CSR-T} and block coefficient C_b</i>
S3	<i>Strength of end bulkheads of superstructures and deckhouses</i>
S4	<i>Criteria for use of high tensile steel with yield points of 315 N/mm² and 355N/mm² (with respect to longitudinal strength)</i>
S5	<i>Calculation of midship section moduli for conventional ship for ship's scantlings</i>
S6	<i>Use of steel grades for various hull members – ships of 90m in length and above</i>
S7	<i>Minimum longitudinal strength Standards</i>
S11	<i>Longitudinal strength Standard</i>
S13	<i>Strength of bottom forward in oil tankers</i>
S14	<i>Testing procedures of Watertight Compartments</i>
S26	<i>Strength and securing of Small Hatches on the Exposed Fore Deck</i>
S27	<i>Strength Requirements for Fore Deck Fittings and Arrangements</i>

3. Design Basis

3.1 General

3.1.1 The design basis

3.1.1.1 This Sub-Section specifies the design parameters and the assumptions about the ship operation that are used as the basis of the design principles of the Rules.

3.1.1.2 The Rules are applicable for ships in compliance with the specified design basis. Special consideration will be given to deviations from this design basis.

3.1.1.3 The design basis used for the design of each ship is to be documented and submitted to the Classification Society as part of the design review and approval. All deviations from the design basis are to be formally advised to the Classification Society.

3.1.2 Arrangement and layout

3.1.2.1 The Rules cover typical double hull tankers of greater than or equal to 150m in length and with arrangements as follows:

- (a) engine room and deck house located aft of the cargo tank region, and
- (b) in addition to the inner skin two longitudinal oil-tight bulkheads with no centreline longitudinal bulkhead, or
- (c) in addition to the inner skin one centreline longitudinal oil-tight bulkhead.

3.1.2.2 The ship's structure is assumed to be:

- (a) constructed of welded steel structures
- (b) composed of stiffened plate panels
- (c) longitudinally framed with full transverse bulkheads and intermediate web frames.

3.1.2.3 The typical arrangements covered by the Rules are shown in **Fig. 2.3.1** and assume that the structural arrangements include:

- (a) narrow double side structure and double bottom structure with breadth/depth in accordance with statutory requirements
- (b) single deck ships
- (c) side longitudinal, centreline longitudinal or transverse bulkheads of plane, corrugated or double skin construction
- (d) the number and location of bulkheads are arranged to comply with the statutory requirements.

The cross sections shown in **Fig. 2.3.1** are typical examples only and other variations of cross tie and web frame arrangements are also covered

Fig. 2.3.1 Typical Arrangements of Double Hull Tankers

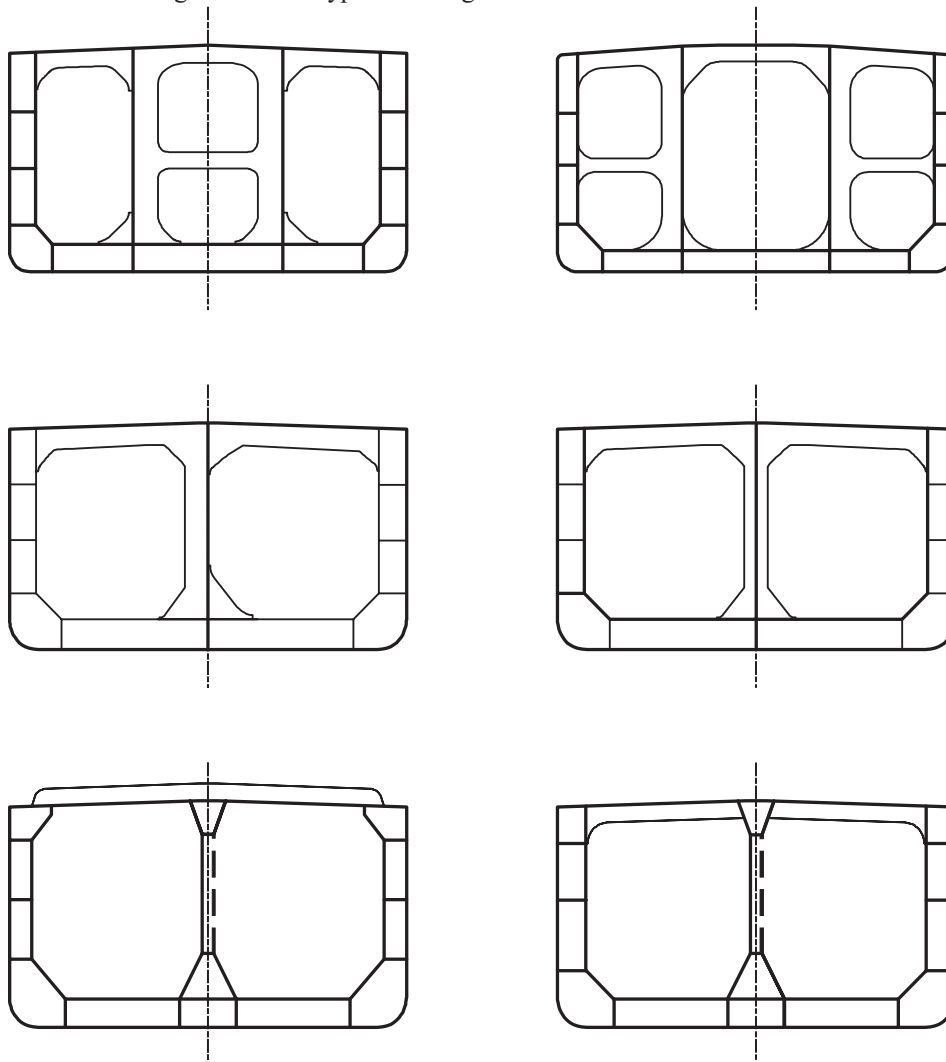

3.1.2.4 The Rules assume the following hull form with respect to environmental loading:

- full form ship with block coefficient (C_b) greater than 0.7
- the ship length breadth ratio (L_{CSR-T}/B) greater than 5
- ship breadth depth ratio (B/D) less than 2.5
- the metacentric height (GM) not greater than $0.12B$ for homogeneously full load conditions, and $0.33B$ for ballast conditions.

3.1.3 Design life

3.1.3.1 A nominal design life of 25 years is assumed for selecting appropriate ship design parameters. The specified design life is the nominal period that the ship is assumed to be exposed to operating conditions. However, the ship's actual service life may be longer or shorter depending on the actual operating conditions and maintenance of the ship throughout its life cycle.

3.1.4 Design speed

3.1.4.1 The design maximum service speed is to be specified by the designer. The Rules assume that the ship is able to operate at this service speed on a continuous basis, but this does not relieve the responsibilities of the owner and personnel to properly handle the ship and reduce speed or change heading in severe weather.

3.1.5 Operating conditions

3.1.5.1 The ship is to be capable of carrying the intended cargo with the necessary flexibility in operation to fulfil its design role. Specification of cargo loading conditions as required by the Rules and any additional cargo loading conditions required by the owner are the responsibility of the designer.

3.1.5.2 The Rules assume the following:

- (a) a minimum set of specified loading conditions as defined in the Rules are examined. These are to include both seagoing and harbour loading conditions
- (b) in addition to the minimum set of specified loading conditions, all relevant additional loading conditions covering the intended ship's service which result in increased still water shear force, bending moments or increased local static loadings are to be submitted for review
- (c) the Trim and Stability Booklet, Loading Manual and loading computer systems specify the operational limitations to the ship and these comply with the appropriate statutory and classification requirements
- (d) all cargo tanks are from a local strength point of view including sloshing designed for unrestricted filling for a cargo density as specified in 3.1.8. Limitations to loading patterns resulting in full or empty adjacent tanks as specified in the Rules and the Loading Manual do however apply for primary support members and hull girder shear force and bending moments.

3.1.6 Operating draughts

3.1.6.1 The design operating draughts are to be specified by the designer and are to be used to derive the appropriate structural scantlings. All operational loading conditions in the Loading Manual are to comply with the specified design operating draughts. The following design operating draughts are as a minimum to be considered:

- (a) the maximum and minimum mean operational draughts
- (b) maximum scantling draught for the assessment of structure
- (c) minimum draughts forward for the assessment of bottom slamming, with and without ballast tanks in way filled
- (d) maximum mean draught for a condition with all cargo tanks abreast empty
- (e) maximum mean draught for a condition with empty centre or wing cargo tank.

3.1.7 External environment

3.1.7.1 To cover worldwide trading operations and also to deal with the uncertainty in the future trading pattern of the ship and the corresponding wave conditions that will be encountered, a severe wave environment is used for the design assessment. The rule requirements are based on a ship trading in the North Atlantic wave environment for its entire design life.

3.1.7.2 The effects of wind and current on the structure are considered to be negligible and hence are not explicitly included.

3.1.7.3 The Rules do not include the effects of ice.

3.1.7.4 The Rules assume that the structural assessment of hull strength members is valid for the following design temperatures:

- (a) lowest daily mean temperature in air is $-10\text{ }^{\circ}\text{C}$
- (b) lowest daily mean temperature in sea water is $0\text{ }^{\circ}\text{C}$

Ships operating for long periods in areas with lower daily mean air temperature may be subject to additional requirements as specified by the individual Classification Society.

3.1.8 Internal environment (cargo and water ballast tanks)

3.1.8.1 A specific gravity (SG) of 1.025, or a higher value if specified by the designer, is to be used for oil cargoes for the strength assessment of cargo tank structures.

3.1.8.2 For the fatigue assessment of cargo tank structures, a representative mean cargo density throughout the ship's life is to be used. The representative mean density is to be taken as 0.9 tonnes/m^3 or the cargo density from the homogeneous full load condition at the full load design draught T_{full} , if this is higher.

3.1.8.3 A SG of 1.025 is to be used for water ballast.

3.1.8.4 The Rules are based on the following design temperatures for the cargo:

- (a) maximum cargo temperature is $80\text{ }^{\circ}\text{C}$
- (b) minimum cargo temperature is $0\text{ }^{\circ}\text{C}$

3.1.8.5 The design aspects and assumption upon which corrosion additions in the Rules are specified are as follows:

- (a) the corrosion additions are based on a combination of experience and a statistical evaluation of historical corrosion measurements. The corrosion additions are based on the carriage of a mixture of crude and other oil products with various degrees of corrosive properties

- (b) the corrosion additions are based on the design life, see **3.1.3.1**
- (c) ballast tanks are coated. Requirements for coating application and maintenance are excluded from the Rules.

3.1.8.6 The values for corrosion additions and wastage allowance are specified in **Section 6/3** and **Section 12** respectively.

3.1.9 Structural construction and inspection

3.1.9.1 The structural requirements included in the Rules are developed with the assumption that construction and repair will follow acceptable shipbuilding and repair standards and tolerances. The Rules may require that additional attention is paid during construction and repair of critical areas of the structure.

3.1.9.2 Tank strength and tightness testing are to be carried out as a part of the verification scheme.

3.1.9.3 The Rules define the renewal criteria for the individual structural items. The structural requirements included are developed on the assumption that the structure will be subject to periodical survey in accordance with individual Classification Society Rules and Regulations. All structural elements are to be arranged to allow access for inspection, see **Section 5/5**. It is assumed that close-up inspection of the critical areas will be carried out on a regular basis.

3.1.10 Owner's extras

3.1.10.1 Owner's specification of requirements above the general classification or statutory requirements may affect the structural design. Owner's extras may include requirements for:

- (a) vibration analysis
- (b) maximum percentage of high strength steel
- (c) additional scantling dimensions above that required by the Rules
- (d) additional design margin on the loads specified by the Rules, etc
- (e) improved fatigue resistance, in the form of a specified increase in design fatigue life or equivalent
- (f) combinations of cargo loading patterns and draughts exceeding the Rule specified conditions
- (g) higher cargo density for fatigue evaluation for ships intended to carry high density cargo in part load conditions on a regular basis.

Owner's extras are not covered by these Rules. Owner's extras that may affect the structural design are to be clearly specified in the design documentation.

4. Design Principles

4.1 Overall Principles

4.1.1 Introduction

4.1.1.1 This Sub-Section defines the underlying design principles of the Rules in terms of loads, structural capacity models and assessment criteria and also construction and in-service aspects.

4.1.2 General

4.1.2.1 The Rules are based on the following overall principles:

- (a) the safety of the structure can be demonstrated by addressing the potential structural failure mode(s) when the vessel is subjected to operational loads and environmental loads/conditions
- (b) the design complies with the design basis, see **Sub-Section 3**
- (c) the structural requirements are based on a consistent set of loads that represent typical worst possible loading scenarios
- (d) the structural requirements with respect to loads, capacity models and assessment criteria are presented in a modular format so that each component of the requirement is clearly identified.

4.1.2.2 The ship's structure is designed such that:

- (a) it has inherent redundancy. The ship's structure works in a hierarchical manner and, as such, failure of structural elements lower down in the hierarchy should not result in immediate consequential failure of elements higher up in the hierarchy
- (b) permanent deformations are minimised. Permanent deformations of local panel or individual stiffened plate members may be acceptable provided that this does not affect the structural integrity, containment integrity or the performance of structural or other systems
- (c) the incidence of in-service cracking is minimised, particularly in locations which; affect the structural integrity or containment integrity, affect the performance of structural or other systems or are difficult to inspect and repair
- (d) it has adequate structural redundancy to survive in the event that the structure is accidentally damaged; for example, minor impact leading to flooding of any compartment.

4.2 Loads

4.2.1 Load scenarios

4.2.1.1 The loads used for assessment of the structure covers the load scenarios encountered by the ship during operation at sea and in harbour.

4.2.2 Design load combinations

4.2.2.1 Design load combinations combine local and global load components to represent identified load scenarios. The design load combinations should be sufficiently severe and varied so as to encompass all scenarios that can reasonably occur during normal operation.

4.2.2.2 The design load combinations for the hull and structural members consider the most unfavourable combination of load effects in order to maintain a consistent safety level for all combinations.

4.2.2.3 The design load combinations are based on one of the following combinations of static and dynamic loads depending on the type of load and the load scenario being considered:

- (a) Static design load combinations (S)
covers application of all relevant static loads and typically covers load scenarios in harbour, tank testing or similar operations
- (b) Static plus Dynamic design load combination (S+D)
covers application of all relevant static loads plus a realistic combination of simultaneously occurring dynamic load components and typically covers load scenarios for seagoing operations
- (c) Impact design load combination

covers application of impact loads such as bottom slamming and bow impact encountered during seagoing operation. It is usually sufficient to ignore other static and dynamic load components in association with an impact load event.

- (d) Sloshing design load combination
covers application of sloshing loads encountered during seagoing operations
- (e) Fatigue design load
covers application of all relevant dynamic loads
- (f) Accidental design load combination (A)
covers application of accidental loads where these loads are not considered as occurring during normal operations

4.2.3 Load categorisation

4.2.3.1 The design load combinations are composed of many different types of loads, which are categorised as shown in **Table 2.4.1**.

Table 2.4.1 Load Categorisations

Operational Loads	Lightship weight	Steel weight and outfit Machinery and permanent equipment
	Buoyancy loads	Buoyancy of the ship
	Variable loads	Cargo Ballast water Stores and consumables Personnel Temporary equipment
	Other loads	Tug and berthing loads Towing loads Anchor and mooring loads Lifting appliance loads
Environmental loads	Cyclic loading due to wave action including inertia loads	Dynamic wave pressures Dynamic loads and dynamic tank pressures due to ship accelerations
	Impact loads or resonant loads	Wave impacts Bottom slamming Liquid sloshing in tanks Green sea loads
Accidental loads		Flooding of compartments
Deformation loads		Thermal loads Deformations due to construction

4.2.3.2 Operational loads generally are static loads. They are grouped into lightship weight, buoyancy loads, variable loads and other loads. The operational loads occur as a consequence of the operation and handling of the ship.

4.2.3.3 Environmental loads are dynamic loads due to external influences. The environmental loads covered by the Rules are loads due to wave action.

4.2.3.4 Accidental loads include loads that result as a consequence of an accident or operational mishandling of the ship. The accidental loads covered by the Rules are increased tank pressures due to flooding of compartments.

4.2.3.5 Deformation loads are caused by thermal loads and residual stresses. The load effects from deformation loads are not covered by the Rules.

4.2.4 Characteristic load values

4.2.4.1 The characteristic values of the load components that are applied in the Rules are dependant on the design load combination being considered. The characteristic loads are typical values and are given by:

- (a) for operational loads the characteristic loads are the expected or specified values
- (b) for environmental loads the characteristic load is typically a load value which has a low probability of occurrence, i.e. an 'extreme' value.

4.2.5 Operational loads

4.2.5.1 The characteristic values of the static sea pressure on the hull due to the buoyancy are based on the draught at the loading condition under consideration.

4.2.5.2 The characteristic values of the static tank pressure are based on the filling height and the specific gravity of the cargo/ballast, and include allowances for possible overpressure due to the height of air pipes, pressure relief valve settings and capacity of pumps.

4.2.5.3 The characteristic values of the loads due to personnel, stores and consumables, temporary equipment and permanent equipment are based on specified values.

4.2.5.4 The characteristic values for tug, berthing, towing and mooring loads are based on specified values.

4.2.6 Environmental loads

4.2.6.1 The Rule formulations for wave loads, as given in **Section 7/3**, are based on the envelope values calculated in accordance with **4.2.6.2** and calibrated with feedback from service experience and model tests.

4.2.6.2 The general principles for the derivation of the wave load values are:

- (a) the application of load values is consistent for all similar load scenarios
- (b) the characteristic load value is selected to suit the purpose of the application of the load and the selected structural assessment method, e.g. for strength assessment the expected lifetime maximum load is applied while for fatigue assessment an average value representing the expected load history is applied
- (c) load calculations are performed using 3-D linear hydrodynamic computational tools. The effects of speed are considered
- (d) the derivation of characteristic wave loads is based on a long term statistical approach which includes representation of the wave environment (North Atlantic scatter diagram), probability of ship/wave heading and probability of load value exceedance based on **IACS Rec. 34**. All of which result in envelope values
- (e) non-linear effects are considered for the expected lifetime maximum loads.

4.2.6.3 The combination of dynamic loads considers all simultaneously occurring dynamic load components. In deriving the simultaneously occurring loads, one particular load component is maximised or minimised and the relative magnitude of all simultaneously occurring dynamic load components is specified by the application of dynamic load combination factors (DLCF) based on the envelope load value. These dynamic load combination factors are based on the application of the equivalent design wave approach and are given as tabulated values.

4.2.6.4 The formulations of the load values for bottom slamming, bow impact loads and green sea loads take account of the following factors:

- (a) vessel draught
- (b) hull form
- (c) heading
- (d) forward speed
- (e) location of deck houses/superstructure
- (f) geometry of structural elements.

4.2.6.5 A slamming impact load results in a transient dynamic response in the structure. The formulation of the impact loads considers the impact load as an equivalent static load acting on the associated exposed hull surface.

4.2.6.6 The effect of green water on the deck structure along the entire vessel's length is considered. The green water loads on fore and parallel mid bodies of a ship are determined based on model tests, ship motion analysis and service experience. The green sea loads for the aft body are consistent with the derivation for the fore and mid body green sea loads.

4.2.7 Accidental loads

4.2.7.1 The accidental load scenarios cover loads acting on local structure as a consequence of flooding in accordance with the assumptions made in IMO regulations. This relates to the assessment of the watertight subdivision boundaries.

4.2.7.2 Only static loads corresponding to the draught in the flooded condition are considered.

4.2.8 Deformation loads

4.2.8.1 Thermal loads within the limits specified by the design basis are considered negligible. It is assumed that care is taken to account for, and allow for, expected thermal expansion.

4.3 Structural Capacity Assessment**4.3.1 General**

4.3.1.1 The basic principle in structural design is to apply the defined design loads, identify possible failure modes and employ appropriate capacity models to determine the required structural scantlings.

4.3.2 Capacity models for strength

4.3.2.1 The strength assessment method is to be capable of analysing the failure mode in question to the required degree of accuracy. Several assessment methods may be applicable, even for the same failure modes.

4.3.2.2 The following aspects are the basis for selection of strength capacity models:

- (a) whether the structural member is also assessed at a higher level in the hierarchy and/or at a later stage by more accurate methods or by more accurate response calculations
- (b) simplified capacity models where some of the stress components are neglected are to always give conservative results
- (c) appropriate methodology to assess the failure mode
- (d) probability level of the load
- (e) capability of response calculations to represent the physical behaviour of the structure up to the given load level
- (f) complexity of structure
- (g) complexity of loads
- (h) criticality of the structural member. This will primarily have an impact on the assessment criteria, but needs to be considered in conjunction with selection of the appropriate methodology for structural assessment.

4.3.2.3 The structural capacity assessment methods are in either a prescriptive format or require the use of more advanced calculations such as finite element analysis methods.

4.3.2.4 The formulae used to determine stresses, deformations and capacity are appropriate for the selected capacity assessment method and the type and magnitude of the design load set.

4.3.3 Capacity models for fatigue

4.3.3.1 The fatigue assessment method provides Rule requirements to safeguard structural details against fatigue failure.

4.3.3.2 The fatigue capacity model is based on a linear cumulative damage summation (Palmgren-Miner's rule) in combination with S-N curves, a characteristic stress range and an assumed long-term stress distribution curve.

4.3.3.3 The fatigue capacity assessment models are in either a prescriptive format or require the use of more advanced calculations such as finite element analysis methods. These methods account for the combined effects of global and local dynamic loads.

4.3.4 Net thickness approach

4.3.4.1 The philosophy behind the net thickness approach is to:

- (a) provide a direct link between the thickness used for strength calculations during the new building stage and the minimum thickness accepted during the operational phase
- (b) enable the status of the structure with respect to corrosion to be clearly ascertained throughout the life of the ship.

4.3.4.2 The net thickness approach distinguishes between local and global corrosion. Local corrosion is defined as uniform corrosion of local structural elements, such as a single plate or stiffener. Global corrosion is defined as the overall average corrosion of larger areas such as primary support members and the hull girder. Both the local and overall corrosion are used as a basis for the new building review and are to be confirmed during operation of the vessel.

4.3.4.3 The net thickness approach for the local corrosion is shown in **Fig. 2.4.1 (a)** and is in terms of new building thicknesses, given by:

- (a) the local strength requirements are given by the net thickness ($t_{net-req}$) after rounding

- (b) the required gross thickness ($t_{grs-req}$) is given by adding the corrosion addition (t_{corr}) to the required rounded net thickness ($t_{net-req}$)
- (c) the gross thickness (t_{grs}) is the actual thickness selected by the designer to fulfil the gross required thickness ($t_{grs-req}$) and is to be equal or greater than the required gross thickness ($t_{grs-req}$)
- (d) the as built thickness is equal to the gross thickness (t_{grs}) plus any additional owners extra margin (t_{own})
- (e) any additional thicknesses specified by the owner, as owners extra margin (t_{own}) are not to be included in the assessment of the required gross thickness ($t_{grs-req}$).

Fig. 2.4.1 Net Thickness Approach for Local Wastage

- (a) application to scanting requirements
- (b) application to ship in operation requirements

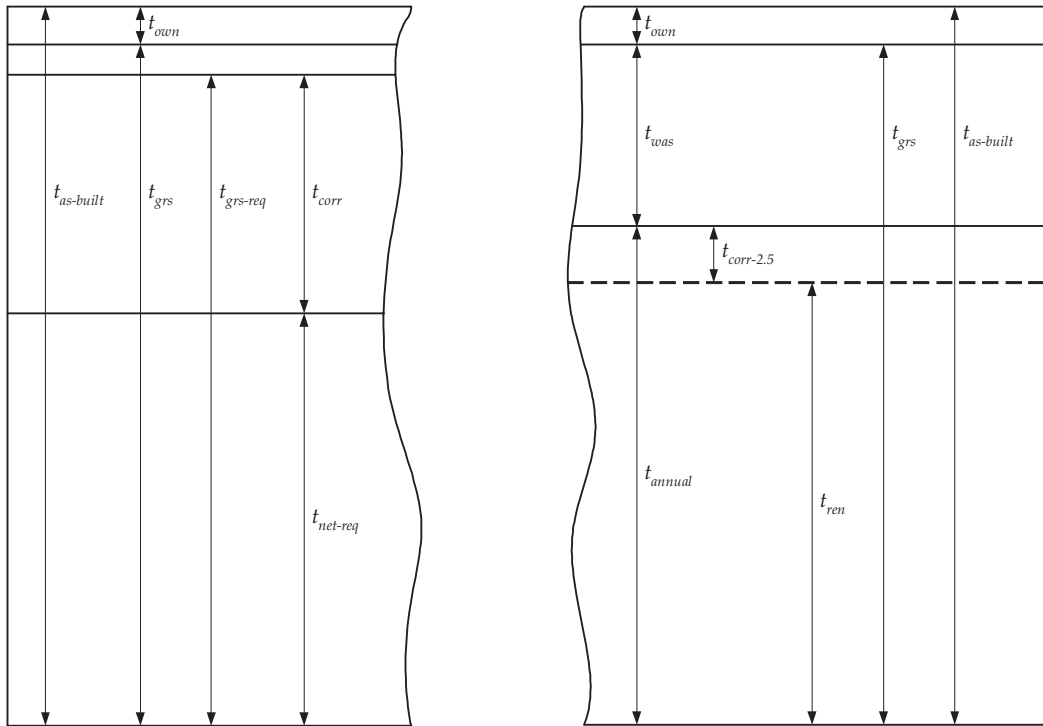

4.3.4.4 The net thickness approach for determining the local renewal thickness during the ship in operation phase is shown in **Fig. 2.4.1 (b)** and is given by:

- (a) the thickness at which annual surveys are required, t_{annual} , is obtained by subtracting the total wastage allowance (t_{was}) and the owners extra margin (t_{own}) from the as-built thickness ($t_{as-built}$)
- (b) thickness at which renewal is required, t_{ren} , is obtained by subtracting the total wastage allowance (t_{was}), the thickness $t_{corr-2.5}$ and the owners extra margin (t_{own}) from the as-built thickness ($t_{as-built}$). Where $t_{corr-2.5}$ is the wastage allowance in reserve for corrosion occurring in the two and half years between Intermediate and Special surveys
- (c) the total wastage allowance given is the rule specified wastage allowance (t_{was}) plus the wastage allowance in reserve ($t_{corr-2.5}$) plus any additional owners extra margin (t_{own})
- (d) the rule specified wastage allowance (t_{was}) available before annual surveys are required is obtained by deducting the thickness $t_{corr-2.5}$ from the corrosion addition (t_{corr}).

The approach calls for a general 2.5 year survey interval when the gauged thickness is greater than the “thickness at which annual surveys are required” (t_{annual}), and a 1 year survey interval when the gauged thickness is less than the “thickness at which annual surveys are required” (t_{annual}).

4.3.4.5 The overall average corrosion for primary support members and the hull girder cross-section is given by deducting half the local corrosion addition ($0.5t_{corr}$) from all structural elements comprising the respective cross-sections.

4.3.4.6 The assessment of local scantlings is performed based on the hull girder stresses given by the net hull girder

properties, e.g. based on a global overall average corrosion of the hull girder, and the local stresses based on the net thickness of the local member under consideration, e.g. based on full local corrosion. It is assumed that the structure may corrode locally to the maximum allowed and that the hull girder may reduce to the maximum allowed overall hull girder corrosion.

4.3.4.7 The assessment of global (hull girder and primary support member) scantlings is based on the overall global corrosion, e.g. half the full local corrosion for all structural members simultaneously. The assumption is that the full local corrosion will not occur globally and hence a lesser average value of assumed corrosion is appropriate. Individual structural elements may corrode to the maximum corrosion addition and this is taken into account in the buckling assessment.

4.3.4.8 As fatigue is an accumulative assessment the scantlings and stresses used for the assessment are to be taken as the representative mean value over the design life. The mean corrosion over the design life is given as half the corrosion assumed for scantling strength assessment. Local stresses are thus calculated based on half the full local corrosion addition and hull girder stresses are calculated based on half the overall global corrosion. Half the global overall corrosion is found by deduction of one quarter of the full local corrosion addition of all structural elements simultaneously.

4.3.4.9 The actual amount of wastage allowed in service is taken as:

- (a) locally: the full corrosion addition less an amount for typical wastage between the survey periods
- (b) globally: the full global overall corrosion addition less an amount for typical wastage between the survey periods. The global wastage is monitored in service by evaluating the current global characteristics of the vessel.

4.3.5 Intact structure

4.3.5.1 All strength calculations are based on the assumption that the structure is intact. The residual strength of the ship in a structurally damaged condition is not assessed.

4.3.5.2 No benefit is given in the assessment of structural capability for the presence of coatings or similar corrosion protection systems.

4.4 Materials and Welding

4.4.1 Materials

4.4.1.1 The Rule requirements associated with the selection of materials for structural components is based on the location, design temperature (see **3.1.7.4** and **3.1.8.4**), membrane, through thickness forces and criticality of the component. The requirements comply with **Chapter 1, Part C** of the Rules.

4.4.1.2 The Rule requirements are based on the assumption that the material is manufactured in accordance with the allowable under thickness rolling tolerances specified in **Part K** of the Rules.

4.4.2 Welding

4.4.2.1 The Rule requirements for weld type, size and materials are based on the following considerations:

- (a) joint type
- (b) criticality of the joint
- (c) magnitude, type and direction of the stresses in the joint
- (d) material properties of the parent and weld material
- (e) weld gap size.

4.5 Assessment/Acceptance Criteria

4.5.1 Design methods

4.5.1.1 The criteria for the assessment of the scantlings are based on one of the following design methods:

- (a) Working Stress Design (WSD) method, also known as the permissible or allowable stress method
- (b) Partial safety Factor (PF) method, also known as Load and Resistance Factor Design (LRFD).

4.5.1.2 For both WSD and PF, two design assessment conditions and corresponding acceptance criteria are given. These conditions are associated with the probability level of the combined loads, A and B:

- (a) condition A is applicable to design load combinations based on 'expected' characteristic load values, typically covered by the static design load combinations

(b) condition B is applicable to design load combinations based on ‘extreme’ characteristic load values, typically covered by the static + dynamic load combinations.

4.5.1.3 The WSD method has the following composition:

$$W_{stat} \leq \eta_1 R \quad \text{for condition A}$$

$$W_{stat} + W_{dyn} \leq \eta_2 R \quad \text{for condition B}$$

Where:

W_{stat} : simultaneously occurring static loads (or load effects in terms of stresses)

W_{dyn} : simultaneously occurring dynamic loads. The dynamic loads are typically a combination of local and global load components

R : characteristic structural capacity (e.g. yield stress or buckling capacity)

η_i : permissible utilisation factor (resistance factor). The utilisation factor includes consideration of uncertainties in loads, structural capacity and the consequence of failure

4.5.1.4 The PF method has the following composition:

$$\gamma_{stat-1} W_{stat} + \gamma_{dyn-1} W_{dyn} \leq \frac{R}{\gamma_R} \quad \text{for condition A}$$

$$\gamma_{stat-2} W_{stat} + \gamma_{dyn-2} W_{dyn} \leq \frac{R}{\gamma_R} \quad \text{for condition B}$$

Where:

γ_{stat} : partial safety factor that accounts for the uncertainties related to static loads

W_{stat} : simultaneously occurring static loads (or load effects in terms of stresses)

γ_{dyn-i} : partial safety factor that accounts for the uncertainties related to dynamic loads

W_{dyn} : simultaneously occurring dynamic loads. The dynamic loads are typically a combination of local and global load components

R : characteristic structural capacity (e.g. yield stress, ultimate hull girder stress)

γ_R : partial safety factor that accounts for the uncertainties related to structural capacity

4.5.1.5 The acceptance criteria for both the WSD method and PF method are calibrated for the various requirements such that consistent and acceptable safety level for all combinations of static and dynamic load effects are achieved.

4.6 Principle of Safety Equivalence

4.6.1 General

4.6.1.1 Novel designs deviating from the design basis or structural arrangements covered by the Rules will be subject to special consideration. The principle of equivalence is to be applied to the novel design, hence it must be demonstrated that the structural safety of the novel design is at least equivalent to that intended by the Rules.

4.6.1.2 The principle of equivalence may be applied to alternative calculation methods.

4.6.1.3 A systematic review process was undertaken in developing these Rules. This identified and evaluated the likely consequences of hazards due to operational and environmental influences on tanker structural configurations and arrangements covered by these Rules. For novel designs, dependent on the nature of the deviation, it may be necessary to conduct an independent systematic review to document equivalence with the Rules.

5. Application of Principles

5.1 Overview of the Application of Principles

5.1.1 General

5.1.1.1 This Sub-Section shows how the design principles described in **Sub-Section 4** have been applied in the development of the rule requirements.

5.2 Structural Design Process

5.2.1 Overview of the structural design process

5.2.1.1 An overview of the structural design process applied in the Rules is shown in **Fig. 2.5.1**.

5.2.1.2 The strength and acceptable safety of the hull and the structural elements is verified through the application of the following Rule requirements:

- (a) prescriptive scantling requirements
 - minimum requirements
 - load-capacity based requirements
- (b) design verification requirements based on load-capacity methods
 - hull girder ultimate strength
 - strength assessment using the Finite Element (FE) analysis
 - fatigue assessment

Fig. 2.5.1 Overview of Structural Design Process

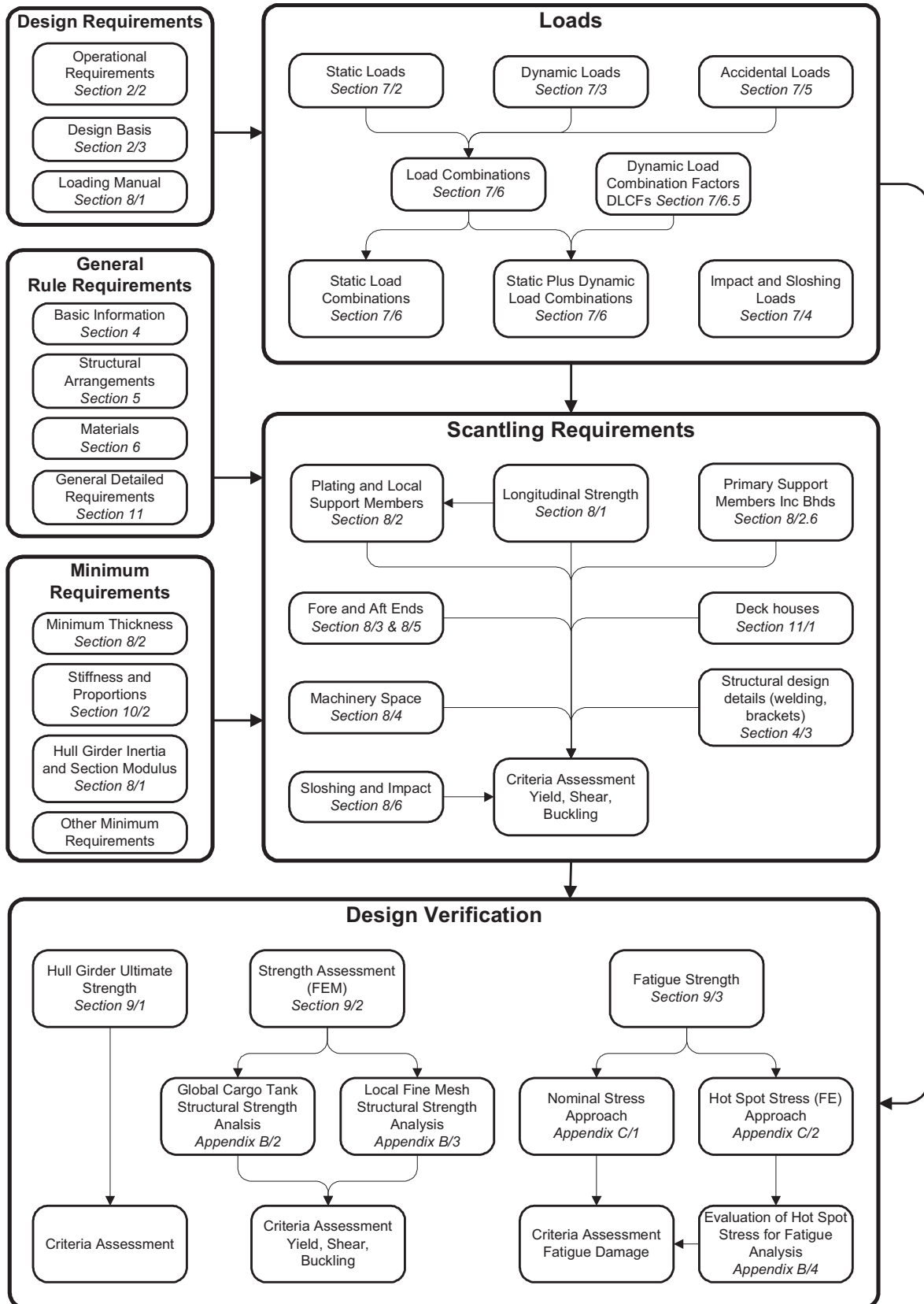

5.3 Minimum Requirements

5.3.1 General

5.3.1.1 The minimum requirements are usually in one of the following forms:

- (a) minimum thickness, which is independent of the yield stress, these are based on service experience and are usually expressed in the following format:

$$t = A + B L_{CSR-T}$$

Where:

A, B : constants

L_{CSR-T} : rule length, as defined in **Section 4/1.1.1.1**

- (b) minimum stiffness and proportion, which are based on prescriptive buckling requirements

5.4 Load-capacity Based Requirements

5.4.1 General

5.4.1.1 In general, the Working Stress Design (WSD) method is applied in the requirements, except for the hull girder ultimate strength criteria where the Partial safety Factor (PF) method is applied. The partial safety factor format is applied for this highly critical failure mode to better account for uncertainties related to static loads, dynamic loads and capacity formulations.

5.4.1.2 The identified load scenarios are addressed by the Rules in terms of design loads, design format and acceptance criteria set, as given in **Table 2.5.1**. The table is schematic and only intended to give an overview.

5.4.1.3 The load scenarios addressed by the rules cover operations such as seagoing conditions, loading and unloading, tank testing conditions, ballast water exchange situations, special operations in harbour (e.g. propeller inspection afloat condition) and accidental flooding.

5.4.1.4 The design load combinations that represent the identified load scenarios are given in **Section 7/6** and are denoted by S (static loads), S+D (static+dynamic loads), and A (accidental loads). In addition, the Rules address impact loads and sloshing loads as given in **Section 7/4** and fatigue loads as given in **Section 7/3**.

5.4.1.5 For the strength requirements, the considered loads cover the most severe operational loads that occur, hence the cargo tank finite element analysis and load-capacity based scantling requirements are based on rule loading conditions which simulate the worst possible loading conditions within the operating limits of the vessel.

5.4.1.6 For the fatigue requirements the considered loads cover an expected load history and representative loading conditions covering the ships' intended service are applied.

5.4.1.7 The acceptance criteria are categorised into three acceptance criteria sets. These are explained below and shown in **Tables 2.5.2** and **2.5.3**. The specific acceptance criteria set that is applied in the WSD rule requirements is dependent on the probability level of the characteristic combined load.

5.4.1.8 The acceptance criteria set AC1 is applied when the combined characteristic loads are frequently occurring, typically for the static design load combinations, but also applied for the sloshing design loads. This means that the loads occur on a frequent or regular basis. The allowable stress for a frequent load is lower than for an extreme load to take into account effects of:

- (a) repeated yield
- (b) allowance for some dynamics
- (c) margins for operational mistakes.

5.4.1.9 The acceptance criteria set AC2 is typically applied when the combined characteristic loads are extreme values, e.g. typically for the static+dynamic design load combinations. High utilisation (η_i in **Table 2.5.1**) of the structural capacity (R_i in **Table 2.5.1**) is allowed in such cases because the considered loads are extreme loads with a low probability of occurrence.

5.4.1.10 The acceptance criteria set AC3 is typically applied for capacity formulations based on the plastic collapse models such as those that are applied to address bottom slamming and bow impact loads.

Table 2.5.1 Load Scenarios and Corresponding Rule Requirements

Load Scenarios		Rule Requirements			
Operation	Loads (that the vessel is exposed to and is to withstand)	Design Load Combination (specified in Section 7/6)		Design Format (specified in Sections 8 and 9) see Note 1	Acceptance Criteria Set (specified in Sections 8 and 9)
		Ref. no	Notation		
Seagoing operations					
Transit	Static and dynamic loads in heavy weather	1	S + D	1. $S_G + S_L + D_G + D_L \leq \eta_2 R_1$	AC2
				2. $\gamma_S S_G + \gamma_D D_G \leq R_2 / \gamma_{R2}$	AC2
	Impact loads in heavy weather	2	Impact	$S_L + D_{imp} \leq \eta_3 R_p$	AC3
	Internal sloshing loads	3	Sloshing	$S_G + D_{slh} \leq \eta_1 R_1$	AC1
	Cyclic wave loads	4	Fatigue	$DM \leq \sum m_i / N_i$	-
BWE by flow through or sequential methods	Static and dynamic loads in heavy weather	5	S + D	$S_G + S_L + D_G + D_L \leq \eta_2 R_1$	AC2
Harbour and sheltered operations					
Loading, unloading and ballasting	Typical maximum loads during loading, unloading and ballasting operations	6	S	$S_G + S_L \leq \eta_1 R_1$	AC1
Tank testing	Typical maximum loads during tank testing operations	7	S	$S_G + S_{L1} \leq \eta_1 R_1$	AC1
Special conditions in harbour	Typical maximum loads during special operations in harbour, e.g. propeller inspection afloat or dry-docking loading conditions	8	S	$S_G + S_L \leq \eta_1 R_1$	AC1
Accidental condition					
Accidental flooding	Typically maximum loads on internal watertight subdivision structure due to accidental flooding	9	A	for water tight boundaries 1. $S_L \leq \eta_2 R_1$	AC2
				for collision bulkhead 2. $S_L \leq \eta_1 R_1$	AC1

Note

1. The symbols defined in this column are defined in the text of 5.4

Where:

- D_G dynamic global load
- D_L dynamic local load
- D_M cumulative fatigue damage ratio
- S_G static global load
- S_L static local load
- R_i structural capacity

5.4.2 Design loads for scantling requirements and strength assessment (FEM)

5.4.2.1 The structural assessment of compartment boundaries, e.g. bulkheads, is based on the worst possible loading, hence conditions are assessed with a full tank on one side and an empty tank on the other side. The situation with the tank content reversed is also considered. Similarly the shell envelope is assessed for conditions at the deepest draught

without internal filling and at the lowest draught with internal filling.

5.4.2.2 The standard loading patterns to be used in the strength assessment (FEM) are given in **Appendix B, Tables B.2.3 and B.2.4** for tankers with two oil-tight longitudinal bulkheads and one centreline oil-tight longitudinal bulkhead respectively. The corresponding information for the scantling requirements is given in **Section 8**.

5.4.2.3 To ensure consistency of approach, standardised rule values for parameters such as GM , $Rroll$, Tsc and Cb are applied to calculate the rule load values.

5.4.2.4 The probability level of the dynamic global and local loads (DG , DL and $Dimp$ in **Table 2.5.1**) is 10^{-8} and are derived using the long term statistical approach specified in **4.2.6.2**.

5.4.2.5 The probability level of the sloshing loads ($Dslh$ in **Table 2.5.1**) is 10^{-4} which is a load that occurs frequently.

5.4.2.6 The design load combinations corresponding to the identified load scenarios produce realistic design load sets suitable for the design and verification of the structural capability. Design load sets apply all the applicable simultaneously acting static and dynamic local load components (SL and DL in **Table 2.5.1**, which are usually pressure load components) and static and dynamic global load components (SG and DG in **Table 2.5.1**, which is usually hull girder bending moment) for the design of a particular or group of structural members. The relevant design load sets for the scantling requirements are given in **Sections 8/2 to 8/5**. The design load sets for the Finite Element analysis are referred to as load cases and are given in **Appendix B**.

5.4.2.7 The simultaneously occurring dynamic loads are specified by applying a dynamic load combination factor to the envelope dynamic load values given in **Section 7/3**. The dynamic load combination factors that define the dynamic load cases are given in **Section 7/6.4** for the structural strength assessment (FE) and in **Section 7/6.5** for the scantling requirements.

5.4.2.8 The dynamic load combination factors have been derived using the equivalent design wave approach to provide realistic simultaneously occurring dynamic loads components suitable for structural assessment.

5.4.2.9 For the determination of design loads for the hull girder ultimate strength requirement given in **Section 9/1**, the operational loads (i.e. ship loading conditions) and the environmental loads (i.e. hull girder wave bending moments) are maximised for sagging conditions for seagoing conditions. The characteristic value for the still water hull girder sagging bending moments M_{sw} is based on the maximum value from the seagoing conditions specified in **Section 8/1**. The characteristic value for the wave hull girder sagging bending moments M_{WV} is given in **Section 7/3**.

5.4.3 Design loads for fatigue requirements

5.4.3.1 For the fatigue requirements given in **Section 9/3** and **Appendix C**, the load assessment is based on the expected load history and an average approach is applied. The expected load history for the design life is characterised by the 10^{-4} probability level of the dynamic load value, the load history for each structural member is represented by Weibull probability distributions of the corresponding stresses.

5.4.3.2 The considered wave-induced loads include:

- (a) hull girder loads (i.e., vertical and horizontal bending moments)
- (b) dynamic wave pressures
- (c) dynamic tank pressures.

5.4.3.3 The fatigue analysis is calculated for two representative loading conditions covering the ship's intended operation. These two conditions are:

- (a) full load homogeneous conditions at design draught
- (b) normal ballast condition. The proportion of the ship's sailing life in the full load condition is 50% and in ballast 50%. It is assumed that 15% of the ships' life is in harbour/sheltered water. It is consequently assumed that the ship will be sailing in open waters in full load condition for 42.5% of the ship's life and in the ballast condition for 42.5% of the ship's life.

The proportion of the ship's sailing life in the full load condition is 50% and in ballast 50%. It is assumed that 15% of the ships' life is in harbour/sheltered water.

5.4.3.4 The load values are based on actual parameters corresponding to the applied loading conditions, e.g. GM , Cb , etc., and the applicable draughts at amidships is used. The actual values are taken from specified loading conditions in the loading manual.

5.4.3.5 The simultaneously occurring dynamic loads are accounted for by combination of stresses due to the various dynamic load components. The stress combination procedure is given in **Appendix C**.

5.4.3.6 Still water loads and static sea and tank pressures from the actual loading conditions are used to determine the mean stress effect.

5.4.4 Structural response analysis

5.4.4.1 In general, the following approaches are applied for determination of the structural response to the applied design load combinations

- (a) Beam theory
 - used for prescriptive requirements
- (b) FE analysis
 - coarse mesh for cargo hold model
 - fine mesh for local models
 - very fine mesh for fatigue assessment

5.4.5 Structural capacity assessment

5.4.5.1 The considered failure modes in the Rules are yield (plastic deformation), buckling, brittle fracture and fatigue. Structural failure due to yield and buckling is primarily controlled by the strength requirements, brittle fracture is primarily controlled by the requirements for material selection and welding, and fatigue failure is primarily controlled by the high cycle fatigue requirements.

5.4.5.2 Generally, the capacity models applied in the prescriptive rules, i.e., the scantling requirements in **Section 8**, are based on simple beam theory and include elastic yield and plastic capacity models. The buckling capacity is assessed using simplified buckling capacity models or by a more theoretical non-linear analysis procedure.

5.4.5.3 The design verification requirements are based on a linear elastic finite element analysis, a detailed prescriptive fatigue assessment procedure and a simplified ultimate strength assessment procedure. There is also a finite element based fatigue assessment procedure for some structural members, such as the hopper knuckle.

5.4.5.4 The application of the net thickness approach to assess the structural capacity is specified in **Section 6/3.3**.

5.4.6 Acceptance criteria

5.4.6.1 The acceptance criteria applied in the working stress design requirements are given as acceptance criteria sets shown in **Tables 2.5.2** and **2.5.3**. There are slight variations within each set depending on the relative contribution of local and global loads, static and dynamic loads and the structural member being considered. The specific acceptance criteria are given in the detailed rule requirements in **Section 8** and **9/2**.

Table 2.5.2 Principal Acceptance Criteria - Rule Requirements

Acceptance criteria set	Plate panels and Local Support Members		Primary Support Members		Hull girder members	
	Yield	Buckling	Yield	Buckling	Yield	Buckling
AC1:	70-80% of yield stress	Control of stiffness and proportions. Usage factor typically 0.8	70-75% of yield stress	Control of stiffness and proportions. Pillar buckling	75% of yield stress	NA
AC2:	90-100% of yield stress	Control of stiffness and proportions. Usage factor typically 1.0	85% of yield stress	Control of stiffness and proportions. Pillar buckling	90-100% of yield stress	Usage factor typically 0.9
AC3:	Plastic criteria	Control of stiffness and proportions	Plastic criteria	Control of stiffness and proportions	NA	NA

Table 2.5.3 Principal Acceptance Criteria - Design Verification - FE Analysis

Acceptance criteria set	Global cargo tank analysis		Local fine mesh analysis
	Yield	Buckling	Yield
AC1:	60-80% of yield stress	Control of stiffness and proportions. Usage factor typically 0.8	local mesh as 136% of yield stress averaged stresses as global analysis
AC2:	80-100% of yield stress	Control of stiffness and proportions. Usage factor typically 1.0	local mesh as 170% of yield stress averaged stresses as global analysis

5.4.6.2 The purpose of applying different sets is to achieve a consistent and acceptable safety level for all combinations of static and dynamic loads and to account for different capacity models.

5.5 Materials

5.5.1 General

5.5.1.1 Higher material properties are selected for highly critical structural elements which are subjected to high loads in order to reduce the risk of propagation of brittle fracture.

5.6 Application of Rule Requirements

5.6.1 Minimum requirements

5.6.1.1 These specify the minimum scantling requirements which are to be applied irrespective of all other requirements, hence thickness below the minimum are not allowed.

5.6.2 Load based prescriptive requirements

5.6.2.1 These provide scantling requirements for all plating, local support members, most primary support members and the hull girder and cover all structural elements including deckhouses, foundations for deck equipment, etc.

5.6.2.2 In general, these requirements explicitly control one particular failure mode and hence several requirements may be applied to assess one particular structural member.

5.6.3 Design verification - hull girder ultimate strength

5.6.3.1 The requirements for the ultimate strength of the hull girder are based on a Partial safety Factor (PF) method, see 4.5. A safety factor is assigned to each of the basic variables, the still water bending moment, wave bending moment and ultimate capacity. The safety factors were determined using a structural reliability assessment approach, the long term load history distribution of the wave bending moment was derived using ship motion analysis techniques suitable for determining extreme wave bending moments.

5.6.3.2 The purpose of the hull girder ultimate strength verification is to demonstrate that one of most critical failure modes of a double hull tanker is controlled.

5.6.4 Design verification - global finite element analysis

5.6.4.1 The global finite element analysis is used to verify the scantlings given by the load-capacity based prescriptive requirements. The analysis is required because the prescriptive requirements do not take into account the complex interactions between the ship's structural components, complex local structural geometry, change in thicknesses and member section properties as well as the complex load regime with sufficient accuracy. Hence the global finite element analysis is necessary to verify the proposed scantlings.

5.6.4.2 A linear elastic three dimensional finite element analysis of the cargo region (a FE model length of three tanks is required) is carried out to assess and verify the structural response of the proposed hull girder and primary support members and assist in specifying the scantling requirements for the primary support members. The purpose with the finite element analysis is to verify that the stresses and buckling capability of the primary support members are within acceptable limits for the applied design loads.

5.6.5 Design verification - fatigue assessment

5.6.5.1 The fatigue assessment is required to verify that the fatigue life of critical structural details is adequate. A prescriptive fatigue requirement is applied to details such as end connections of longitudinal stiffeners using an SN curve approach based on geometric details, i.e. Class F, F2, etc. A hot spot fatigue assessment procedure using finite element analysis is applied to details such as the hopper knuckle. In both cases, the fatigue assessment method is based on the Palmgren-Miner linear damage model.

5.6.6 Relationship between the prescriptive scantling requirements and the strength assessment (FEM)

5.6.6.1 The prescriptive minimum requirements define the minimum acceptable scantlings. These may not to be reduced by any form of alternative calculations such as load-capacity prescriptive requirements or strength analysis such as FEM.

5.6.6.2 The section modulus and/or shear area of a primary support member and/or the cross sectional area of a primary support member cross tie may be reduced to 85% of the prescriptive requirements provided that the reduced scantlings comply with the strength assessment (FEM).

5.6.6.3 The philosophy is that a coarse approach should be more conservative than a detailed approach. Hence, the prescriptive requirements are generally more conservative than the corresponding requirements based on strength assessment (FEM).

Section 3 RULE APPLICATION

1. Notations

1.1 Notations

1.1.1 General

1.1.1.1 Ships fully complying with the requirements of this part and the specific requirements of the Society relating to construction, survey and equipment will be eligible to be assigned with character symbols and a ship type notation appropriate to the Society.

1.1.1.2 In addition to **1.1.1.1**, ships fully complying with the requirements of this part will also be assigned the notation **CSR**.

2. Documentation, Plans and Data Requirements

2.1 Documentation and Data Requirements

2.1.1 Loading information

2.1.1.1 Loading guidance information containing sufficient information to enable the master of the ship to maintain the ship within the stipulated operational limitations is to be provided onboard the ship. The loading guidance information is to include an approved loading manual and loading computer system complying with the requirements given in **Sections 8/1.1.2** and **8/1.1.3** respectively.

2.1.2 Submission of calculation data and results

2.1.2.1 Where calculations have been carried out in accordance with the procedures given in the Appendices of this part, one copy of the following supporting information is to be submitted as applicable:

- (a) reference to the calculation procedure and technical program used
- (b) a description of the structural modelling
- (c) a summary of the analysis parameters including properties and boundary conditions
- (d) details of the loading conditions and the means of applying loads
- (e) a comprehensive summary of calculation results
- (f) sample calculations where appropriate.

2.1.2.2 In general, submission of large volumes of input and output data associated with programs, such as finite element analysis, will not be required.

2.1.2.3 The responsibility for error free specification and input of program data and the subsequent correct transposal of output resides with the designer.

2.1.3 Use of computer software for rule calculations

2.1.3.1 In general, any rule computation program recognised by the Society may be employed to determine scantlings according to this part provided the implementation given in **5.1** is complied with.

2.1.3.2 A computer program that has been demonstrated to produce reliable results to the satisfaction of the Society is regarded as a recognised program. Where the computer programs employed are not supplied or recognised by the Society, full particulars of the computer program, including example calculation output, are to be submitted. It is recommended that the designers consult the Society on the suitability of the computer programs intended to be used prior to the commencement of any analysis work.

2.2 Submission of Plans and Supporting Calculations

2.2.1 General

2.2.1.1 In general, the main categories and lists of information required are given in **2.2.2**. Additional requirements for some items are also given in subsequent sections as applicable.

2.2.1.2 Plans are generally to be submitted in triplicate, but one copy only is necessary for supporting documents and calculations. Additional copies may be required according to the Society requirements.

2.2.1.3 Plans are to contain all necessary information to fully define the structure, including construction details, materials, welding and loads imposed on the structure by equipment and systems as appropriate.

2.2.1.4 Plans are to include information related to the renewal thickness as specified in **Section 12**.

2.2.2 Plans and supporting calculations

2.2.2.1 In general, plans covering the following items are to be submitted:

- (a) main scantling plans:
 - midship sections showing longitudinal and transverse structural members
 - construction profiles/plans showing all main longitudinal structural elements along the ships length including decks, inner bottom, bulkheads, double side stringers and double bottom girders
 - shell expansion
 - main oil-tight and watertight transverse bulkheads including primary support members

- (b) loading guidance information:
 - preliminary loading manual
 - final loading manual
 - details of the design basis, see **Section 8/1.1.2**
 - test conditions for the loading instrument
- (c) detailed construction plans:
 - cargo tank construction plans showing the variations in detail arrangements and scantlings of double bottom floors, double side webs and other transverse primary support members
 - fore end
 - aft end
 - engine room construction including the engine and thrust bearing seating
 - deckhouses and superstructures
- (d) detail design plans except where the information is already included on plans listed in (a) and (c):
 - sternframe
 - hull penetration plans
 - welding
 - bilge keels
 - booklet of standard design details
 - anchoring and mooring equipment
 - pillar and girder support arrangements for decks
 - access arrangements through double bottom and side skin spaces in the cargo tank region
 - details and arrangements of openings and attachments to the hull structure for means of access for inspection purposes
- (e) plans detailing support structures except where the information is already included on plans listed in (a) to (d):
 - anchoring windlass and chain stopper
 - mooring winches
 - masts, derrick posts or cranes
 - emergency towing equipment
 - other deck equipment or fittings

2.2.2.2 The following supporting documents are to be submitted:

- (a) general arrangement
- (b) capacity plan
- (c) lines plan or equivalent
- (d) dry-docking plan, where developed
- (e) freeboard plan or equivalent, showing freeboards and items relative to the conditions of assignment

2.2.2.3 The following supporting calculations are to be submitted:

- (a) calculation of the equipment number.

2.2.2.4 Plans of items not covered by this part are to be submitted according to the requirements in **Chapter 2, Part B**.

2.2.3 Plans to be supplied onboard the ship

2.2.3.1 One copy of the following plans indicating the new-building and renewal thickness for each structural item:

- (a) main scantling plans as given in **2.2.2.1(a)**
- (b) one copy of the final approved loading manual, see **2.1.1**
- (c) one copy of the final loading instrument test conditions, see **Section 8/1.1.3**
- (d) detailed construction plans as given in **2.2.2.1(c)**
- (e) welding
- (f) details of the extent and location of higher tensile steel together with details of the specification and mechanical properties, and any recommendations for welding, working and treatment of these steels
- (g) details and information on use of special materials, such as aluminium alloy, used in the hull construction.
- (h) towing and mooring arrangements plan, see **Section 11/3.1.6.16**

3. Scope of Approval

3.1 General

3.1.1 Rule application

3.1.1.1 Further to the information contained in **Section 1/1.1.1** and **Section 1/1.2.1**, this part covers the scantling requirements for the classification of new double hull tankers of 150m or greater in length.

3.1.1.2 The attention of owners, designers, and builders is directed to the regulations of international, national, canal, and other authorities dealing with those requirements which may affect structural aspects, in addition to or in excess of the classification requirements.

3.1.1.3 Other aspects of the structural design not covered by this part are to be addressed using the rules of the Society.

3.2 Classification

3.2.1 General

3.2.1.1 The documentation, plans and data requirements specified in **Sub-Section 2** are to be submitted. The Society will review such documentation to verify compliance with the requirements.

3.2.1.2 An appropriate term to indicate that the plans, reports or documents have been reviewed for compliance with this part will be used according to **the REGULATIONS FOR THE CLASSIFICATION AND REGISTRY OF SHIPS**.

4. Equivalence Procedure

4.1 General

4.1.1 Rule applications

4.1.1.1 This part applies in general to double hull oil tankers of normal form, proportions, speed and structural arrangements. Relevant design parameters defining the assumptions made are given in **Section 2/3**.

4.1.1.2 This part is applicable to steel ships of welded construction. Other materials for use in hull construction will be specially considered.

4.1.1.3 Special consideration will be given to the application of this part incorporating design parameters which are outside the design basis of **Section 2/3**, for example:

- (a) increased fatigue life
- (b) increased corrosion additions
- (c) increased cargo density.

4.1.2 Novel designs

4.1.2.1 Ships of novel design, i.e. those of unusual form, proportions, speed and structural arrangements outside those reflected in **Section 2/3.1.2** of this part will be specially considered according to the contents of this sub-section.

4.1.2.2 Information is to be submitted to the Society to demonstrate that the structural safety of the novel design is at least equivalent to that intended by this part.

4.1.2.3 In such cases, the Society is to be contacted at an early stage in the design process to establish the applicability of this part and additional information required for submission.

4.1.2.4 Dependent on the nature of the deviation, a systematic review may be required to document equivalence with this part.

4.1.3 Alternative calculation methods

4.1.3.1 Where indicated in specific sections of this part, alternative calculation methods to those shown in this part may be accepted provided it is demonstrated that the scantlings and arrangements are of at least equivalent strength to those derived using the Rule calculation method.

5. Calculation and Evaluation of Scantling Requirements

5.1 Determination of Scantling Requirements for Plates

5.1.1 Determination of scantlings of plate strakes - idealisation of plate panels

5.1.1.1 Scantlings of plate strakes are to be derived based on the idealisation of the as-built structure as a series of Elementary Plate Panels (EPP).

5.1.1.2 An EPP is the unstiffened part of the plating between stiffeners. The plate panel length, l_{epp} , and breadth, s_{epp} , of the EPP are defined in relation to the longest and shortest plate edges respectively, as shown in **Fig. 3.5.1**.

5.1.1.3 For strength assessment, the idealisation of EPP may be different and take into account the mesh arrangement in the FEM model.

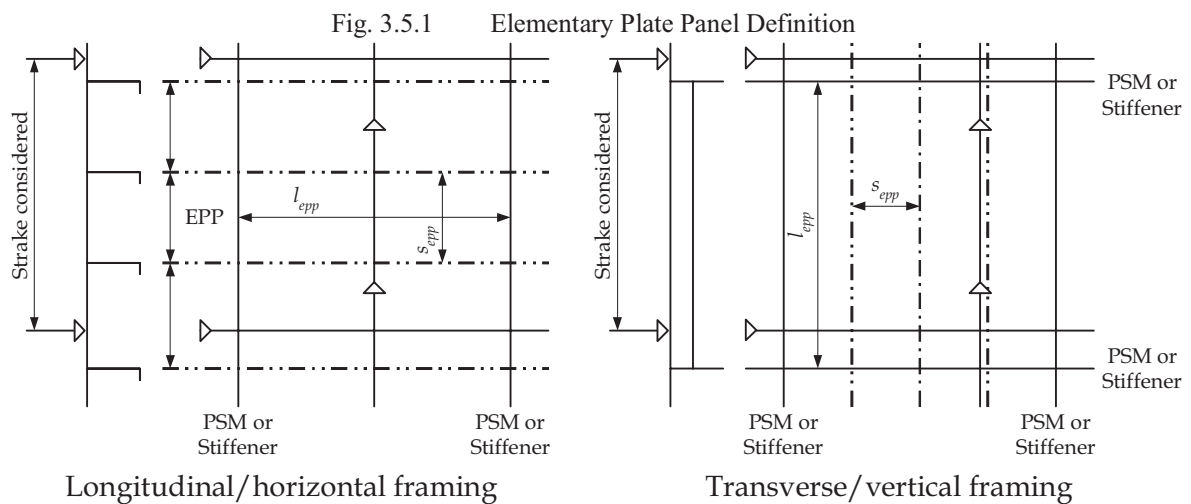

5.1.1.4 The required scantling of a plate strake is to be taken as the greatest value required for each EPP within that strake as given by:

- (a) an EPP positioned entirely within the strake boundaries, e.g. EPP2 in **Fig. 3.5.2**
- (b) an EPP with a strake boundary weld seam bisecting it predominantly in the direction of the long edge of the EPP, e.g. EPP1, 3, 4 and 6 in **Fig. 3.5.2**
- (c) an EPP with a strake boundary weld seam bisecting it predominantly in the direction of the short edge of the EPP within more than half the EPP breadth, s_{epp} , from the edge, e.g. EPP1 and EPP2 in **Fig. 3.5.3(a)**.

Fig. 3.5.2 Determining Elementary Plate Panels for a Strake

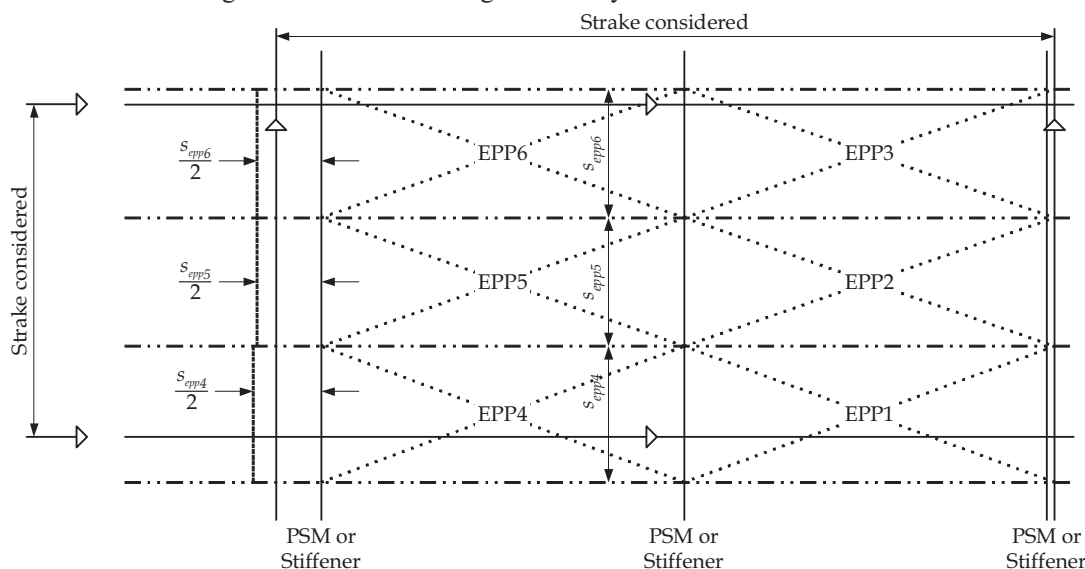

5.1.2 Determination of scantlings of elementary plate panels for scantling requirements

5.1.2.1 The required scantling of each elementary plate panel is to be calculated based on a Load Calculation Point (LCP) defined as:

- for longitudinal framing, at the mid length of the EPP measured along the global x -axis at its lower edge. For horizontal plating the load calculation point is to be taken at the outboard y -value of the EPP. See **Fig. 3.5.3(a)**
- for transverse framing, at the mid length of the EPP measured along the global x -axis at the lower edge of strake. For horizontal plating the load calculation point is to be taken at the outboard y -value of the EPP. See **Fig. 3.5.3(b)**
- for horizontal framing on vertical transverse structure, at the lower edge of the elementary plate panel at the point of outboard y -value of the EPP. See **Fig. 3.5.3(c)**
- for vertical framing on vertical transverse structure, at the greatest y -value of the lower edge of the EPP or at the lower edge of strake. See **Fig. 3.5.3(d)**

5.1.2.2 Both the local pressure and hull girder stress used for the calculation of the local scantling requirements are to be taken at the LCP.

5.1.3 Determination of scantlings of elementary plate panels for hull girder strength

5.1.3.1 The required scantlings of the elementary plate panels are to satisfy the hull girder bending and hull girder shear requirements of **Section 8/1**.

5.1.3.2 The required thickness of each elementary plate panel, with respect to buckling, is to be calculated based on stresses taken at the mid length of the EPP measured along the global x -axis.

5.1.3.3 The buckling evaluation is to be calculated using the stress distribution across the width of the panel defined with a reference stress taken at the edge with maximum stress and reduced stress at the other edge given as a fraction, φ , defined in **Table 10.3.1**, of the reference stress.

5.1.3.4 The required scantling of a plate strake is to be taken as the greatest value required for each EPP within that strake as given by:

- an EPP positioned entirely within the strake boundaries, e.g. EPP2 in **Fig. 3.5.2**
- an EPP with a strake boundary weld seam bisecting it predominantly in the direction of the long edge of the EPP, e.g. EPP 1, 3, 4 and 6 in **Fig. 3.5.2**
- an EPP with a strake boundary weld seam bisecting it predominantly in the direction of the short edge of the EPP within more than half the EPP breadth, s_{EPP} , from the edge, e.g. EPP 1 and 2 in **Fig. 3.5.3(a)**.

5.1.4 Determination of scantlings of elementary plate panels for FEM strength assessment

5.1.4.1 The required scantlings of elementary plate panels are to be derived from the plate mesh element with maximum utilisation, see **Section 9/2**.

Fig. 3.5.3 Example of Load Calculation Point for Typical Structural Configurations
(a) Longitudinal Framing

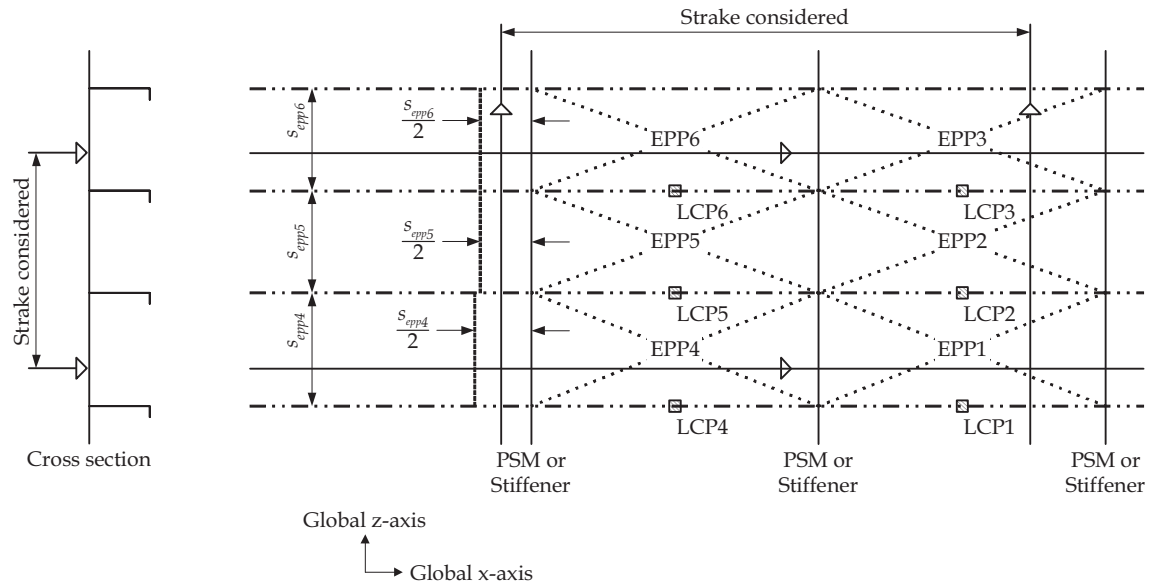

(b) Transverse Framing

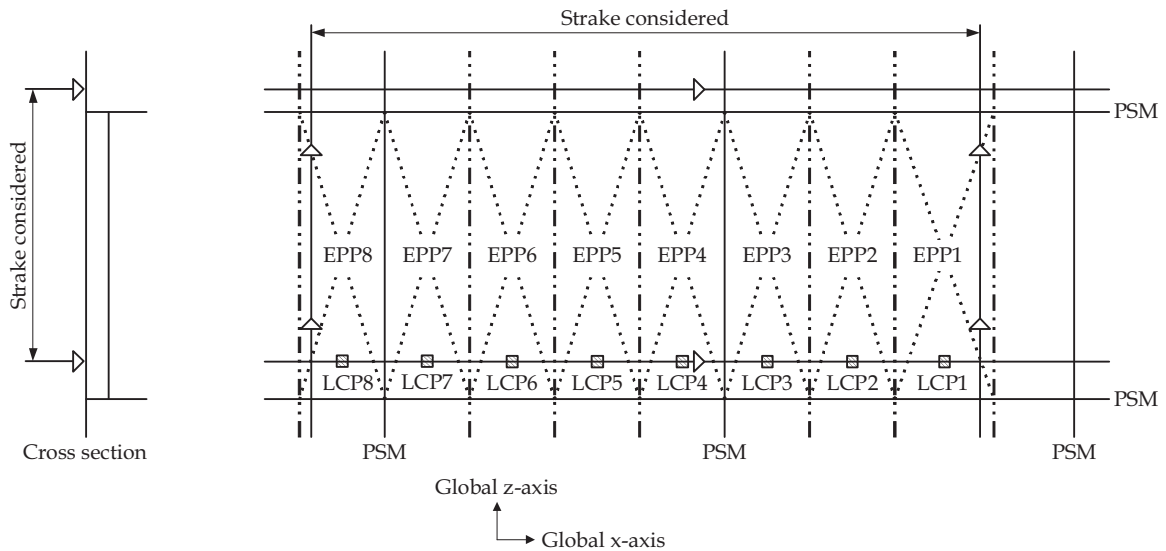
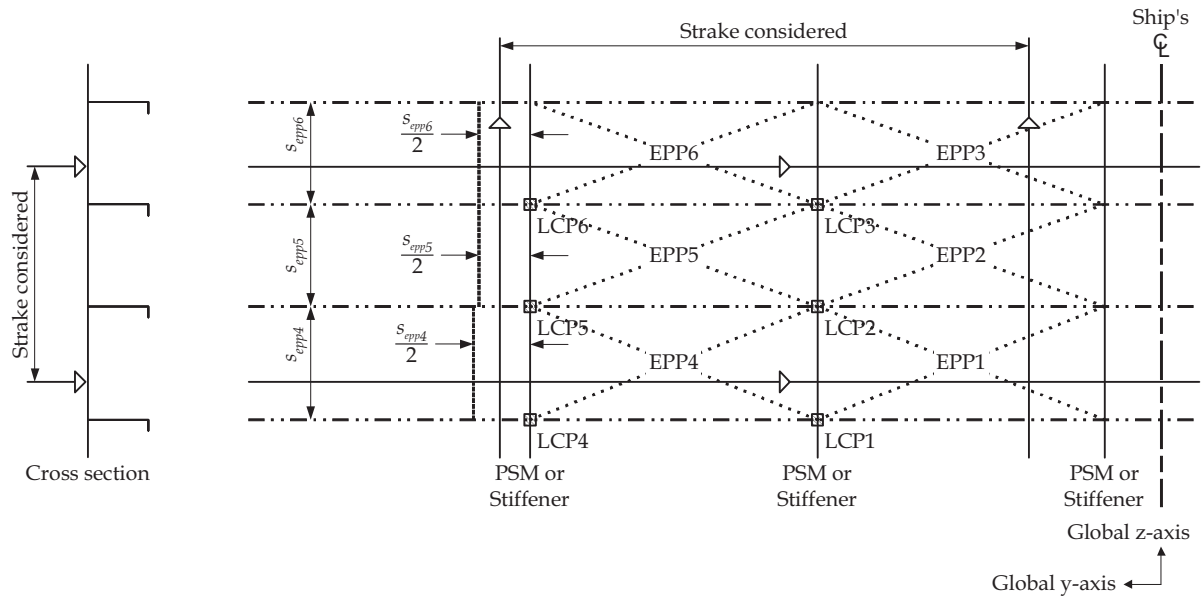
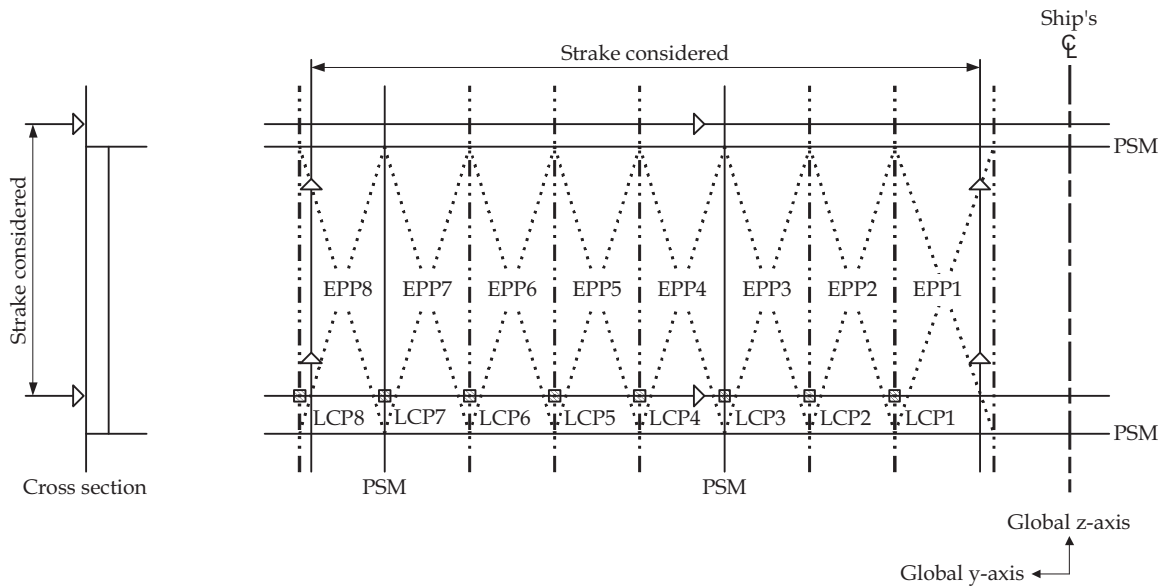

Fig. 3.5.3 (Continued) Example of Load Calculation Point for Typical Structural Configurations
(c) Horizontal Framing on Transverse Structure



(d) Vertical Framing on Transverse Structure



5.2 Determination of Scantlings of Stiffeners

5.2.1 Determination of scantlings of stiffeners - idealisation of stiffeners

5.2.1.1 Scantlings of individual stiffeners are to be derived based on the idealisation of the as-built structure as a series of stiffened panels.

5.2.1.2 A stiffened panel consists of a single idealised stiffener profile and effective plate flange supporting a boundary of one or more elementary plate panels. The arrangement of stiffened panels is based on the idealisation of the structure according to the elementary plate panel definition in 5.1.1.

5.2.1.3 Scantlings of stiffeners based on requirements in Section 8 may be decided based on the concept of grouping designated sequentially placed stiffeners of equal scantlings. The scantling of the group is to be taken as the greater of the following:

- (a) the average of the required scantling of all stiffeners within a group
- (b) 90% of the maximum scantling required for any one stiffener within the group.

The concept of grouping is not applicable to fatigue requirements as given in Section 9/3 and Appendix C.

5.2.2 Determination of scantlings of stiffened panels for scantling requirements and fatigue

5.2.2.1 The required scantling of a stiffened panel is to be based on a pressure load calculation point defined as:

- (a) mid point of the overall span, l_{full} , of the stiffener between primary support members, see **Fig.3.5.4**
- (b) at the connection of the stiffener to the plating.

Fig. 3.5.4 Definition of Overall Span of Stiffeners, l_{full}
Double Skin Construction

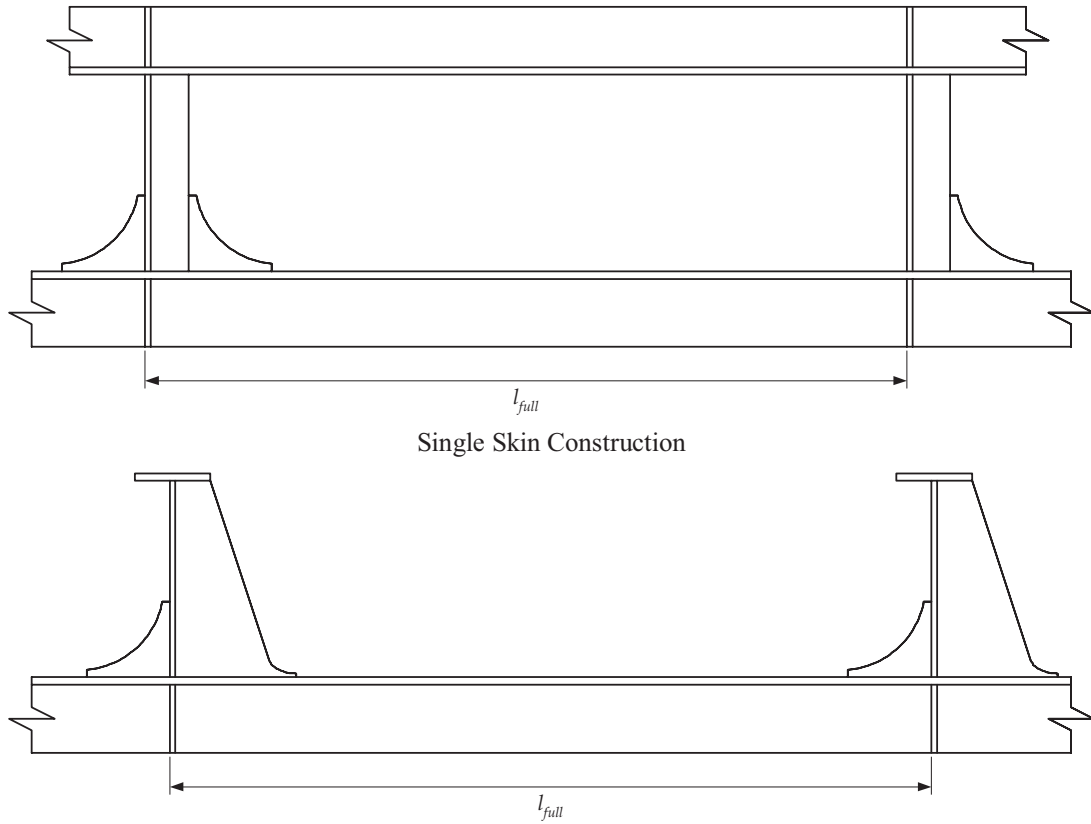

5.2.2.2 For longitudinal and horizontal framing the design pressure is to be taken as the pressure at the mid point of the overall span.

5.2.2.3 For transverse and vertical framing the design pressure is to be taken as the greater of the following:

$$P_{ms} \quad (kN/m^2)$$

$$\frac{(P_{end-1} + P_{end-2})}{2} \quad (kN/m^2)$$

Where:

P_{ms} : calculated pressure at mid point of overall span, l_{full} , in kN/m^2

P_{end-1} : calculated pressure at 1st end of overall span, in kN/m^2

P_{end-2} : calculated pressure at 2nd end of overall span, in kN/m^2

l_{full} : overall span, in m , see **Fig. 3.5.4**

5.2.2.4 The section modulus requirements given in this part relate to the reference point giving the minimum section modulus. In general, this will be on the outer surface of the faceplate. The reference point for calculation of section modulus for typical profiles is shown in **Fig. 3.5.5**.

5.2.2.5 The hull girder stress used for calculation of local scantling requirements for stiffeners is to be taken at the reference point as shown in **Fig. 3.5.5**

Fig. 3.5.5 Reference Point for Calculation of Section Modulus and Hull Girder Stress for Local Scantling Assessment

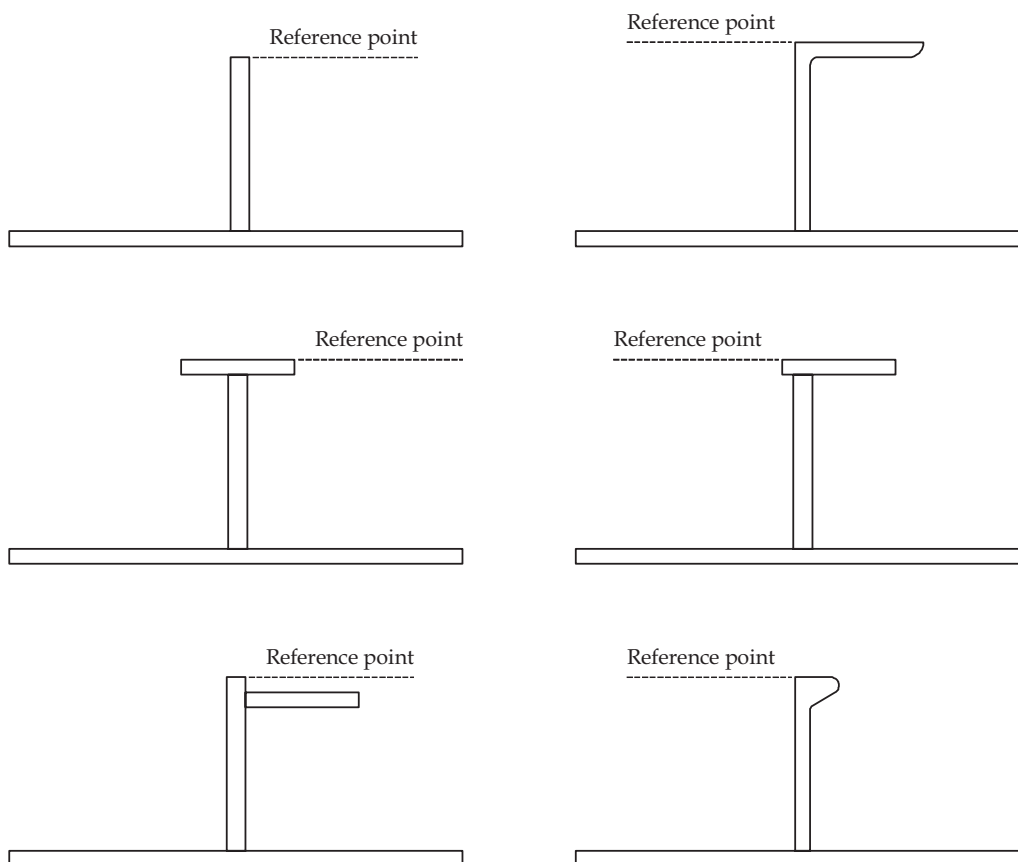

5.2.3 Determination of scantlings of stiffened panels for hull girder buckling strength

5.2.3.1 The required scantling of a stiffened panel, with respect to buckling, is to be based on the axial stress calculated at the attachment point of the stiffener to the plate and at the mid length of the stiffener measured along the global x -axis.

5.2.3.2 The required scantling as given in 5.2.3.1 applies to stiffeners outside of a distance s from the support, where s is the stiffener spacing.

5.2.4 Determination of scantlings of stiffened panels for FEM strength assessment

5.2.4.1 The required scantlings of the stiffened panel are to be based on the derivation of applied stresses in accordance with Section 9/2.

5.2.5 Shear area requirements of stiffeners

5.2.5.1 Requirements for the shear area and/or web thickness of stiffeners are given in Section 8.

5.2.5.2 The requirements in Section 8 are to be calculated based on the load point defined in 5.2.2 and the effective span as given in Section 4/2.1.2.

5.2.5.3 The requirements in Section 8 are to be evaluated against the actual shear area of the stiffener, based on the effective shear height of the stiffener as given in Section 4/2.4.2 and based on the specified minimum yield of the stiffener.

5.2.5.4 The effect of brackets may be included in the calculation of the effective span, but no part of the bracket is to be included in the calculation of the actual shear area.

5.2.6 Bending requirements of stiffeners

5.2.6.1 Requirements for the section modulus and moment of inertia of stiffeners are given in Section 8.

5.2.6.2 The requirements in Section 8 are to be calculated based on the load point defined in 5.2.2 and the effective span as given in Section 4/2.1.1.

5.2.6.3 The requirements in **Section 8** are to be evaluated against the actual section modulus/moment of inertia of the stiffener. The stiffener web and flanges are to be included in the calculation of actual sectional properties.

5.2.6.4 The effect of brackets may be included in the calculation of the effective span, but no part of the bracket is to be included in the calculation of section modulus/moment of inertia.

5.2.6.5 When the stiffener is of a higher strength material than the attached plate, the yield stress used for the calculation of the section modulus requirements in **Section 8** is in general not to be greater than 1.35 *times* the minimum specified yield stress of the attached plate. If the yield stress of the stiffener exceeds this limitation the following criterion is to be satisfied:

$$\sigma_{yd-stf} \leq \left(\sigma_{yd-plt} - |\sigma_{hg}| \right) \frac{Z_{net-plt}}{Z_{net}} + |\sigma_{hg}| \quad (N/mm^2)$$

Where:

σ_{yd-stf} : specified minimum yield stress of the material of the stiffener, in N/mm^2

σ_{yd-plt} : specified minimum yield stress of the material of the attached plate, in N/mm^2

σ_{hg} : maximum hull girder stress of sagging and hogging (S+D), in N/mm^2 , as defined in **Table 8.2.5** and **Table 8.4.3** for stiffeners in cargo tank region and machinery spaces respectively and not to be taken as less than $0.4 \sigma_{yd-plt}$

Z_{net} : net section modulus, in way of face plate/free edge of the stiffener, in cm^3

$Z_{net-plt}$: net section modulus, in way of the attached plate of stiffener, in cm^3

5.2.7 Evaluation of slanted stiffeners

5.2.7.1 The shear area and section modulus requirements for local support members are valid about an axis parallel to the plate flange. If the angle φ_w between the stiffener web and the attached plating is less than 75 *degrees*, see **Fig. 4.2.14**, then the actual shear area and section modulus is to be adjusted in accordance with **Sections 4/2.4.2** and **2.4.3**. The angle between the stiffener web, φ_w , and the attached plating is not to be less than 50 *degrees*.

5.3 Calculation and Evaluation of Scantling Requirements for Primary Support Members

5.3.1 Load application point for primary support members

5.3.1.1 The design pressure for primary support members is generally taken at the mid point of the load area. The design pressures for the primary support members are defined for individual members as given in **Section 8**.

5.3.2 Shear requirements of primary support members

5.3.2.1 Requirements for shear area and/or web thickness of primary support members are given in **Section 8**.

5.3.2.2 These requirements are to be calculated based on the load point defined in **5.3.1** and the effective span as given in **Section 4/2.1.5**.

5.3.2.3 These requirements are to be evaluated against the actual shear area and the specified minimum yield of the web plate of the primary support member. The actual shear area of the primary support member is defined in **Section 4/2.5.1**. The effect of brackets may be included in the calculation of effective span, but are not to be included in the calculation of actual shear area.

5.3.3 Bending requirements of primary support members

5.3.3.1 Requirements for section modulus and moment of inertia of primary support members are given in **Section 8** and **Section 10**, respectively.

5.3.3.2 These requirements are to be calculated based on the load point defined in **5.3.1** and the effective span as given in **Section 4/2.1.4**.

5.3.3.3 These requirements are to be evaluated against the actual section modulus/moment of inertia of the primary support member. Web and flanges are included in the calculation of actual sectional properties. The effect of brackets may be included in calculation of effective span, but are not to be included in the calculation of section modulus/moment of inertia.

5.3.3.4 Where it is impracticable to fit a primary support member with the required web depth, then it is permissible to fit a member with reduced depth provided that the fitted member has equivalent moment of inertia or deflection to the required member. The required equivalent moment of inertia is to be based on an equivalent section given by the effective width of plating at mid span with required plate thickness, web of required depth and thickness and face plate of sufficient width and thickness to satisfy the required mild steel section modulus. All other rule requirements,

such as minimum thicknesses, slenderness ratio, section modulus and shear area, are to be satisfied for the member of reduced depth. The equivalent moment of inertia may be also demonstrated by an equivalent member having the same deflection as the required member.

5.4 Rounding of Calculated Thickness

5.4.1 Required gross thickness

5.4.1.1 The minimum required gross thickness of any member to be fitted at the new-building stage, exclusive of any owners' extras, is to be taken as the rounded net thickness required plus the appropriate corrosion addition.

5.4.1.2 The required net thickness is given by rounding the calculated net thickness to the nearest half millimetre. For example:

- (a) for $10.75 \leq t_{calc-net} < 11.25 \text{ mm}$ the Rule required thickness is 11 mm
- (b) for $11.25 \leq t_{calc-net} < 11.75 \text{ mm}$ the Rule required thickness is 11.5 mm .

Section 4 BASIC INFORMATION

1. Definitions

1.1 Principal Particulars

1.1.1 L_{CSR-T} , rule length

1.1.1.1 L_{CSR-T} , the rule length, is the distance on the waterline at the scantling draught, from the forward side of the stem to the centreline of the rudder stock, in metres. L_{CSR-T} is not to be less than 96%, and need not be greater than 97%, of the extreme length on the summer load waterline. In ships with an unusual stern and bow arrangement the length, L_{CSR-T} , will be specially considered.

1.1.2 L_L , load line length

1.1.2.1 L_L , the load line length is defined in the *International Convention on Load Lines*.

1.1.3 Moulded breadth

1.1.3.1 B , the moulded breadth, is the maximum breadth of the ship, measured amidships to the moulded line of the frame, in metres.

1.1.4 Moulded depth

1.1.4.1 D , the moulded depth, is the vertical distance, in metres, amidships, from the moulded baseline to the moulded deck line of the uppermost continuous deck measured at deck at side. On vessels with a rounded gunwale, D is to be measured to the continuation of the moulded deck line.

1.1.5 Draughts

1.1.5.1 T , the draught in metres, is the summer load line draught for the ship in operation, measured from the moulded base line at amidships. Note this may be less than the maximum permissible summer load waterline draught.

1.1.5.2 T_{bal} , is the minimum design ballast draught, in metres, at which the strength requirements for the scantlings of the ship are met. The minimum design ballast draught is not to be greater than the minimum draught of ballast conditions including ballast water exchange operation, measured from the moulded base line at amidships, for any ballast loading condition in the loading manual including both departure and arrival conditions.

1.1.5.3 T_{bal-n} , the normal ballast draught in metres, is the draught at departure given for the normal ballast condition in the loading manual, measured from the moulded base line at amidships, see **Section 8/1.1.2.3**. The normal ballast condition is the ballast condition in compliance with condition specified in **Section 8/1.1.2.2(a)**.

1.1.5.4 T_{full} , the full load design draught in metres, is the draught at departure given for the homogeneous full load condition in the loading manual, measured from the moulded base line at amidships, see **Section 8/1.1.2.3**.

1.1.5.5 T_{sc} , is the maximum design draught, in metres, at which the strength requirements for the scantlings of the ship are met.

1.1.6 Amidships

1.1.6.1 Amidships is to be taken as the middle of the rule length, L_{CSR-T} .

1.1.7 Moulded displacement

1.1.7.1 Δ , the moulded displacement, in tonnes, corresponding to the underwater volume of the ship, at draught T_{sc} , in sea water with a density of $1.025t/m^3$.

1.1.8 Maximum service speed

1.1.8.1 V , the maximum ahead service speed, in *knots*, means the greatest speed which the ship is designed to maintain in service at her deepest sea-going draught at the maximum propeller RPM and corresponding engine MCR (Maximum Continuous Rating).

1.1.9 Block coefficient

1.1.9.1 C_b , the block coefficient at the scantling draught, is defined as:

$$C_b = \frac{\nabla}{L_{CSR-T} B_{WL} T_{sc}}$$

Where:

∇ : moulded displacement volume at the scantling draught, in m^3

L_{CSR-T} : rule length, as defined in **1.1.1.1**

B_{WL} : moulded breadth measured amidships, in m , at the scantling draught waterline

T_{sc} : scantling draught, as defined in **1.1.5.5**

1.1.9.2 C_{b-LC} , the block coefficient at considered loading condition, is defined as:

$$C_{b-LC} = \frac{\nabla_{LC}}{L_{CSR-T} B_{WL} T_{LC}}$$

Where:

∇_{LC} : moulded displacement volume at the T_{LC} , in m^3

L_{CSR-T} : rule length, as defined in **1.1.1.1**

B_{WL} : moulded breadth measured amidships, in m , at the T_{LC}

T_{LC} : draught at amidships, in m , in the loading condition being considered.

1.1.10 Length between perpendiculars

1.1.10.1 L_{pp} , the length between perpendiculars, is the distance, in metres, on the scantling draught waterline from the fore side of the stem to the after side of the rudder post, or to the centre of the rudder stock if there is no rudder post.

1.1.11 The forward perpendicular

1.1.11.1 $F.P.$, the forward perpendicular, is the perpendicular at the intersection of the scantling draught waterline with the fore side of the stem. The $F.P.$ is the forward end of the rule length, L_{CSR-T} .

1.1.12 The aft perpendicular

1.1.12.1 $A.P.$, the aft perpendicular, is the perpendicular at the aft end of the rule length, L_{CSR-T} , measured from the $F.P.$

1.1.13 Load line block coefficient

1.1.13.1 C_{bL} , the load line block coefficient, is defined in the *International Convention on Load Lines* as follows:

$$C_{bL} = \frac{\nabla_L}{L_L B_L T_L}$$

Where:

∇_L : moulded displacement volume at the moulded draught, T_L , in m^3

L_L : load line length, as defined in **1.1.2.1**

B_L : moulded breadth, in m , as defined in **1.1.3.1**

T_L : the moulded draught measured to the waterline at 85% of the least moulded depth, in m

1.1.14 Deadweight

1.1.14.1 DWT , is the deadweight of the ship, in tonnes, floating in water with a specific gravity of 1.025, at the summer load line draught.

1.2 Position 1 and Position 2

1.2.1 Position 1

1.2.1.1 Position 1 is defined as any location upon exposed freeboard and raised quarterdecks, and exposed superstructure decks within the forward $0.25L_L$.

1.2.2 Position 2

1.2.2.1 Position 2 is defined as any location upon exposed superstructure decks abaft the forward $0.25L_L$.

1.3 Type 'A' and Type 'B' Freeboard Ships

1.3.1 ICLL definition

1.3.1.1 A Type 'A' or Type 'B' freeboard ship is as defined in the *International Convention on Load Lines*.

1.4 Coordinate System

1.4.1 Origin and orientation

1.4.1.1 The coordinate system used within this Part is shown in **Fig. 4.1.1**. Motions and displacements are considered positive in the forward, up and to port direction. Angular motions are considered positive in the clockwise direction about the x , y or z axis.

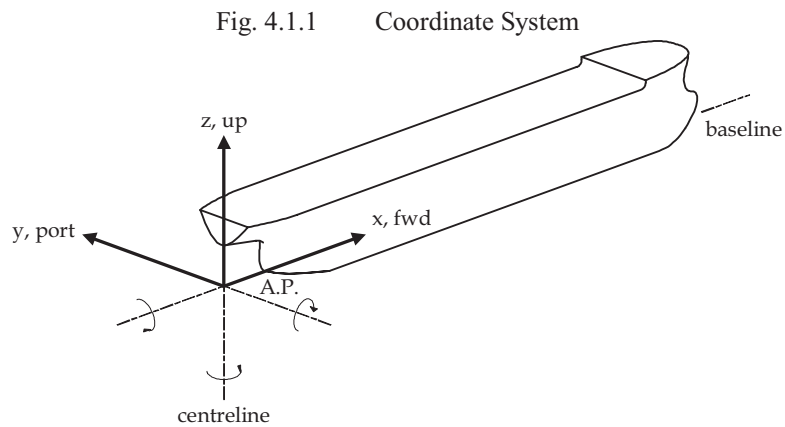

1.5 Naming Convention

1.5.1 Bulkhead nomenclature

1.5.1.1 Fig. 4.1.2, 4.1.3 and 4.1.4 show the common structural nomenclature used within this Part.

Fig. 4.1.2 Corrugated Transverse Bulkhead Nomenclature

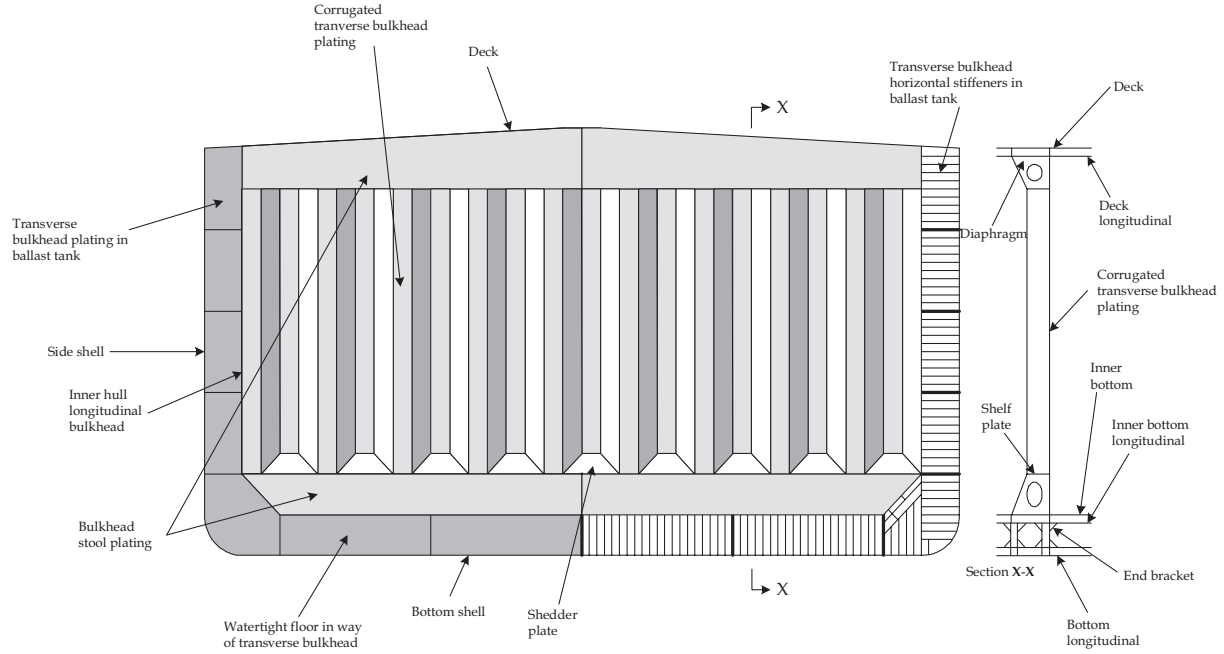

Fig. 4.1.3 Flat Transverse Bulkhead Nomenclature

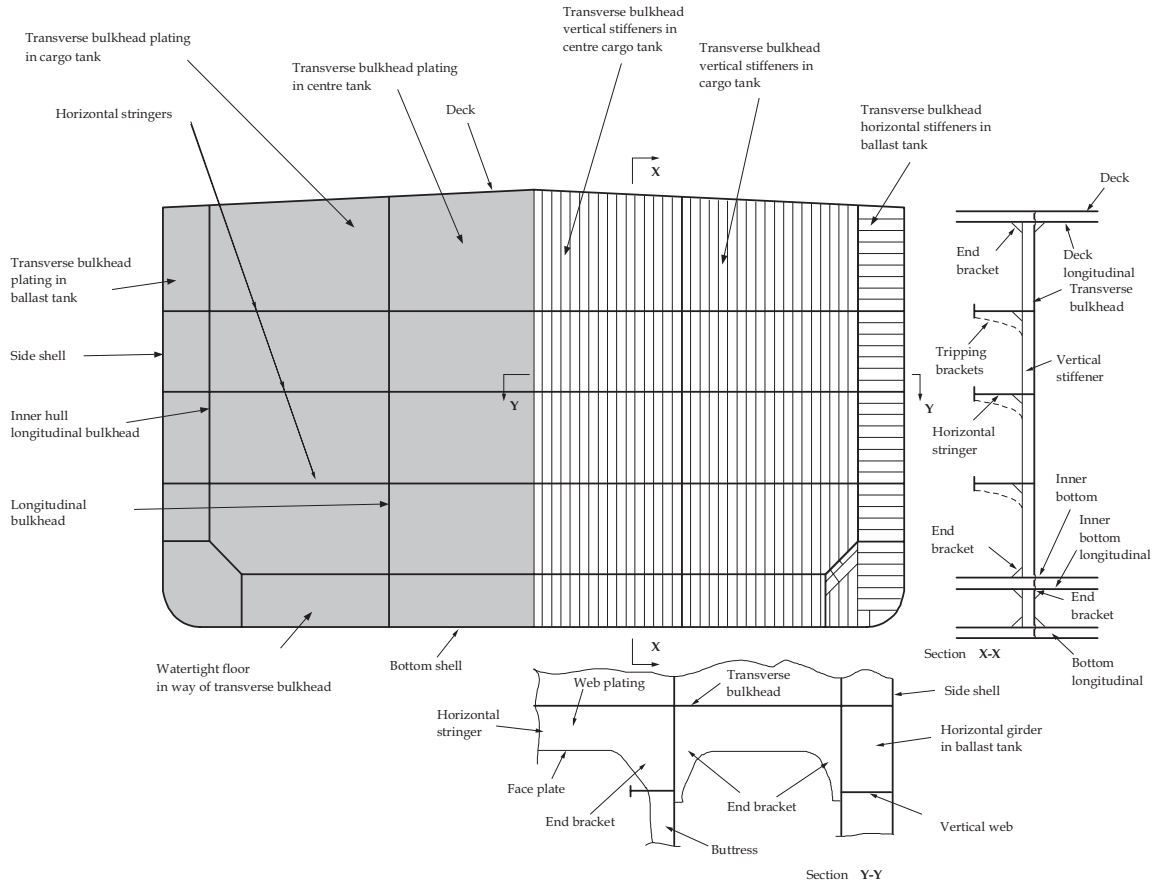
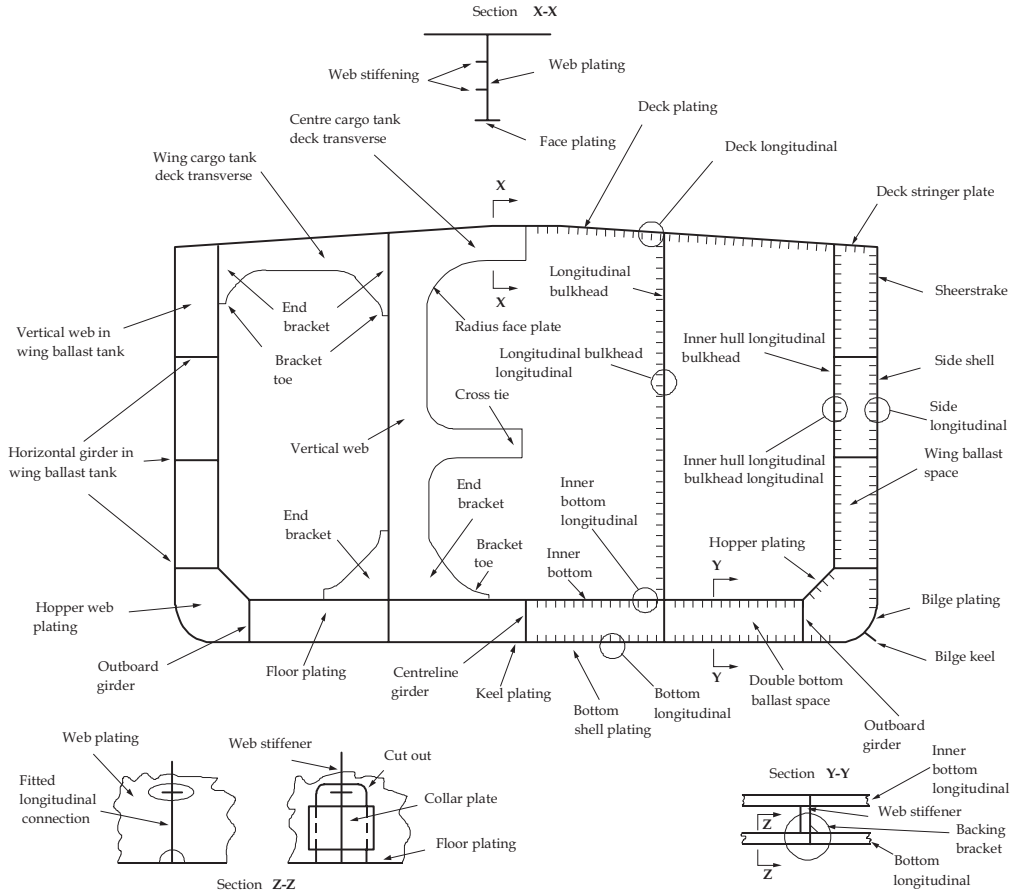

Fig. 4.1.4 Mid Cargo Hold Transverse Section



1.6 Symbols

1.6.1 General

1.6.1.1 The symbols and subscripts used within this Part are defined locally. The principal particulars, as defined in 1.1, may be referred to within text without reference.

1.7 Units

1.7.1 General

1.7.1.1 The following units are used within this Part. The units to be used within equations are given locally.

- (a) General:
- dimensions/distances m
 - primary spacings m
 - secondary spacings mm
 - area m^2
 - volume m^3
 - mass t
 - velocity m/s
 - acceleration m/s^2
- (b) Hull girder properties:
- dimensions m
 - area m^2
 - section modulus m^3
 - moment of inertia m^4
 - moment of area m^3
- (c) Stiffener properties:
- dimensions mm
 - area cm^2
 - section modulus cm^3
 - inertia cm^4
 - length/effective length m
 - span m
- (d) Plating dimensions:
- breadth mm
 - length m
 - thickness mm
- (e) Loads:
- pressures kN/m^2
 - loads kN
 - bending moment kNm
 - shear force kN
- (f) Miscellaneous:
- yield strength N/mm^2
 - stress N/mm^2
 - deflections mm
 - modulus of elasticity N/mm^2
 - density t/m^3
 - displacement t
 - angle deg
 - calculated angle rad
 - period s
 - frequency Hz
 - ship speed $knots$

1.8 Glossary

1.8.1 Definitions of terms

1.8.1.1 The terms in **Table 4.1.1** are used within this Part to describe the items which their respective definitions describe.

Table 4.1.1 Definitions of Terms

Terms	Definition
Accommodation deck	A deck used primarily for the accommodation of the crew
Accommodation ladder	A portable set of steps on a ship's side for people boarding from small boats or from a pier
Aft peak	The area aft of the aft peak bulkhead
Aft peak bulkhead	The first main transverse watertight bulkhead forward of the stern
Aft peak tank	The compartment in the narrow part of the stern aft of the aft peak bulkhead
Anchor	a device which is attached to anchor chain at one end and lowered into the sea bed to hold a ship in position; it is designed to grip the bottom when it is dragged by the ship trying to float away under the influence of wind and current; usually made of heavy casting or casting
Ballast tank	A compartment used for the storage of water ballast
Bay	The area between adjacent transverse frames or transverse bulkheads
Bilge keel	A piece of plate set perpendicular to a ship's shell along the bilges to reduce the rolling motion
Bilge plating	The area of curved plating between the bottom shell and side shell. To be taken as follows: From the start of the curvature at the lower turn of bilge on the bottom to the lesser of, the end of curvature at the upper turn of the bilge on the side shell or 0.2D above the baseline/local centreline elevation
Bilge strake	The lower strake of bilge plating
Boss	The boss of propeller is the central part to which propeller blades are attached and through which the shaft end passes
Bottom shell	The shell envelope plating forming the predominantly flat bottom portion of the shell envelope including the keel plate
Bow	The structural arrangement and form of the forward end of the ship
Bower Anchor	An anchor carried at the bow of the ship
Bracket	An extra structural component used to increase the strength of a joint between two structural members
Bracket toe	The narrow end of a tapered bracket
Breakwater	Inclined and stiffened plate structure on a weather deck to break and deflect the flow of water coming over the bow
Breast hook	A triangular plate bracket joining port and starboard side structural members at the stem
Bridge	An elevated superstructure having a clear view forward and at each side, and from which a ship is steered
Bulb profile	A stiffener utilising an increase in steel mass on the outer end of the web instead of a separate flange
Bulkhead	A structural partition wall sub-dividing the interior of the ship into compartments
Bulkhead deck	The uppermost continuous deck to which transverse watertight bulkheads and shell are carried
Bulkhead stool	The lower or upper base of a corrugated bulkhead
Bulkhead structure	The transverse or longitudinal bulkhead plating with stiffeners and girders
Bulwark	The vertical plating immediately above the upper edge of the ship's side surrounding the exposed deck(s)
Bunker	A compartment for the storage of fuel oil used by the ship's machinery
Cable	A rope or chain attached to the anchor
Camber	The upward rise of the weather deck from both sides towards the centreline of the ship
Cargo tank bulkhead	A boundary bulkhead separating cargo tanks

Table 4.1.1 (Continued) Definitions of Terms

Terms	Definition
Cargo area	The part of the ship that contains cargo tanks and cargo/slop tanks and adjacent areas including ballast tanks, fuel tanks, cofferdams, void spaces and also including deck areas throughout the entire length and breadth of the part of the ship over the mentioned spaces. It includes the collision bulkhead and the transverse bulkhead at the aft end of the cargo block.
Carlings	A stiffening member used to supplement the regular stiffening arrangement
Casing	The covering or bulkhead around or about any space for protection
Cellular construction	A structural arrangement where there are two closely spaced boundaries and internal diaphragm plates arranged in such a manner to create small compartments
Centreline girder	A longitudinal member located on the centreline of the ship
Chain	Connected metal rings or links used for holding anchor, fastening timber cargoes, etc.
Chain locker	A compartment usually at the forward end of a ship which is used to store the anchor chain
Chain pipe	A section of pipe through which the anchor chain enters or leaves the chain locker
Chain stopper	A device for securing the chain cable when riding at anchor as well as securing the anchor in the housed position in the hawse pipe, thereby relieving the strain on the windlass
Coaming	The vertical boundary structure of a hatch or skylight
Cofferdams	The spaces between two bulkheads or decks primarily designed as a safeguard against leakage of oil from one compartment to another
Collar plate	A patch used to, partly or completely, close a hole cut for a longitudinal stiffener passing through a transverse web
Collision bulkhead	The foremost main transverse watertight bulkhead
Companionway	A weathertight entrance leading from a ship's deck to spaces below
Compartment	An internal space bounded by bulkheads or plating
Confined space	A space identified by one of the following characteristics: limited openings for entry and exit, unfavourable natural ventilation or not designed for continuous worker occupancy
Corrugated bulkhead	A bulkhead comprised of plating arranged in a corrugated fashion
Cross ties	Large transverse structural members joining longitudinal bulkheads and used to support them against hydrostatic and hydrodynamic loads
Deck	A horizontal structure element that defines the upper or lower boundary of a compartment
Deck house	A decked structure other than a superstructure, located on the freeboard deck or above
Deck structure	The deck plating with stiffeners, girders and supporting pillars
Deep tank	Any tank which extends between two decks or the shell/inner bottom and the deck above or higher
Discharges	Any piping leading through the ship's sides for conveying bilge water, circulating water, drains etc.
Docking bracket	A bracket located in the double bottom to locally strengthen the bottom structure for the purposes of docking
Double bottom structure	The shell plating with stiffeners below the top of the inner bottom and other elements below and including the inner bottom plating
Doubler	Small piece of plate which is attached to a larger area of plate that requires strengthening in that location. Usually at the attachment point of a stiffener
Double skin member	Double skin member is defined as a structural member where the idealized beam comprises webs, with top and bottom flanges formed by attached plating
Duct keel	A keel built of plates in box form extending the length of the cargo tank. It is used to house ballast and other piping leading forward which otherwise would have to run through the cargo tanks
Enclosed superstructure	The superstructure with bulkheads forward and/or aft fitted with weather tight doors and closing appliances
Engine room bulkhead	A transverse bulkhead either directly forward or aft of the engine room

Table 4.1.1 (Continued) Definitions of Terms

Terms	Definition
Face plate	The section of a stiffening member attached to the plate via a web and is usually parallel to the plated surface
Flange	The section of a stiffening member, typically attached to the web, but is sometimes formed by bending the web over. It is usually parallel to the plated surface
Flat bar	A stiffener comprising only of a web
Floor	A bottom transverse member
Forecastle	A short superstructure situated at the bow
Fore peak	The area of the ship forward of the collision bulkhead
Fore peak deck	A short raised deck extending aft from the bow of the ship
Freeboard deck	Generally the uppermost complete deck exposed to weather and sea, which has permanent means of closing all exposed openings
Freeing port	An opening in the bulwarks to allow water shipped on deck to run freely overboard
Gangway	The raised walkway between superstructure, such as between the forecastle and bridge, or between the bridge and poop
Girder	A collective term for primary supporting structural members
Gudgeon	A block with a hole in the centre to receive the pintle of a rudder; located on the stern post, it supports and allows the rudder to swing
Gunwale	The upper edge of the ship's sides
Gusset	A plate, usually fitted to distribute forces at a strength connection between two structural members
Hatch ways	Openings, generally rectangular, in a ship's deck affording access into the compartment below
Hawse pipe	Steel pipe through which the hawser or cable of anchor passes, located in the ship's bow on either side of the stem, also known as spurling pipe
Hawser	Large steel wire or fibre rope used for towing or mooring
Hopper plating	Plating running the length of a compartment sloping between the inner bottom and vertical portion of inner hull longitudinal bulkhead
HP	Holland Profile
Independent tank	A self supporting tank
Inner hull	The innermost plating forming a second layer to the hull of the ship
Intercostal	Longitudinal member between the floors or frames of a ship; it is non-continuous
JIS	Japanese industrial standard profile
Keel	The main structural member or backbone of a ship running longitudinal along centreline of bottom. Usually a flat plate stiffened by a vertical plate on its centreline inside the shell
Knuckle	A discontinuity in a structural member
Lightening hole	A hole cut in a structural member to reduce its weight
Limber hole	A small drain hole cut in a frame or plate to prevent water or oil from collecting
Local support members	Local support members are defined as local stiffening members which only influence the structural integrity of a single panel, e.g. deck beams
Longitudinal centreline bulkhead	A longitudinal bulkhead located on the centreline of the ship
Longitudinal hull girder structural members	Structural members that contribute to the longitudinal strength of the hull girder, including: deck, side, bottom, inner bottom, inner hull longitudinal bulkheads including upper sloped plating where fitted, hopper, bilge plate, longitudinal bulkheads, double bottom girders and horizontal girders in wing ballast tanks
Longitudinal hull girder shear structural members	Structural members that contribute to strength against hull girder vertical shear loads, including: side, inner hull longitudinal bulkheads, hopper, longitudinal bulkheads and double bottom girders
Manhole	A round or oval hole cut in decks, tanks, etc., for the purpose of providing access

Table 4.1.1 (Continued) Definitions of Terms

Terms	Definition
Margin plate	The outboard strake of the inner bottom and when turned down at the bilge the margin plate (or girder) forms the outer boundary of the double bottom
Notch	A discontinuity in a structural member caused by welding
Oil fuel tank	A tank used for the storage of fuel oil
Pillar	A vertical support placed between decks where the deck is unsupported by the shell or bulkhead
Pintle	Vertical pin on a rudder's forward edge that enables the rudder to hang onto the stern post and swing when it fits into the gudgeon
Pipe tunnel	The void space running in the midships fore and aft lines between the inner bottom and shell plating forming a protective space for bilge, ballast and other lines extending from the engine room to the tanks
Poop	The space below an enclosed superstructure at the extreme aft end of a ship
Poop deck	The first deck above the shelter deck at the aft end of a ship
Primary support members	Members of the beam, girder or stringer type which ensure the overall structural integrity of the hull envelope and tank boundaries, e.g. double bottom floors and girders, transverse side structure, deck transverses, bulkhead stringers and vertical webs on longitudinal bulkheads
Rudder	A device, usually of an aerofoil or flat section, that is used to steer a ship. A common type has a vertical fin at the stern and is able to move from 35 degrees port to 35 degrees starboard; rudders are characterised by their area, aspect ratio, and shape
Scallop	A hole cut into a stiffening member to allow continuous welding of a plate seam
Scarfig bracket	A bracket used between two offset structural items
Scantlings	The physical dimensions of a structural item
Scupper	Any openings for carrying off water from a deck, either directly or through piping
Scuttle	A small opening in a deck or elsewhere, usually fitted with a cover or lid or a door for access to a compartment
Shedder plates	Slanted plates that are fitted to minimise pocketing of residual cargo in way of corrugated bulkheads
Sheer strake	The top strake of a ship's side shell plating
Shelf plate	A horizontal plate located on the top of a bulkhead stool
Shell envelope plating	The shell plating forming the effective hull girder
Side shell	The shell envelope plating forming the side portion of the shell envelope above the bilge plating
Single skin member	Single skin member is defined as a structural member where the idealized beam comprises a web, with a top flange formed by attached plating and a bottom flange formed by a face plate
Skylight	A deck opening fitted with or without a glass port light and serving as a ventilator for engine room, quarters, etc.
Slop tank	A tank in an oil tanker which is used to collect the oil and water mixtures from cargo tanks after tank washing
Spaces	Separate compartments including tanks
Stay	Bulwark and hatch coaming brackets
Stem	The piece of bar or plating at which a ship's outside plating terminates at forward end
Stern frame	The heavy strength member in single or triple screw ships, combining the rudder post
Stern tube	A tube through which the shaft passes to the propeller; and acts as an after bearings for the shafting and may be water or oil lubricated
Stiffener	A collective term for secondary supporting structural members
Stool	A structure supporting tank bulkheads
Strake	A course, or row, of shell, deck, bulkhead, or other plating
Strength deck	The uppermost continuous deck
Stringer	Horizontal girders linking vertical web frames

Table 4.1.1 (Continued) Definitions of Terms

Terms	Definition
Stringer plate	The outside strake of deck plating
Superstructure	A decked structure on the freeboard deck, extending from side to side of the ship or with the side plating not being inboard of the shell plating more than 0.04B
Tank top	The horizontal plating forming the bottom of a cargo tank
Towing pennant	A long rope which is used to effect the tow of a ship
Transom	The structural arrangement and form of the aft end of the ship
Transverse ring	All transverse material appearing in a cross-section of the ship's hull, in way of a double bottom floor, vertical web and deck transverse girder
Transverse web frame	The primary transverse girders which join the ships longitudinal structure
Tripping bracket	A bracket used to strengthen a structural member under compression, against torsional forces
Tween deck	An abbreviation of between decks, placed between the upper deck and the tank top in the cargo tanks
Ullage	The quantity represented by the unoccupied space in a tank
Void	An enclosed empty space in a ship
Wash bulkhead	A perforated or partial bulkhead in a tank
Watertight	Watertight means capable of preventing the passage of water through the structure under a head of water for which the surrounding structure is designed
Weather deck	A deck or section of deck exposed to the elements which has means of closing weathertight, all hatches and openings
Weathertight	Weathertight means that in any sea conditions water will not penetrate into the ship
Web	The section of a stiffening member attached perpendicular to the plated surface
Wind and water strakes	The strakes of a ship's side shell plating between the ballast and the deepest load waterline
Windlass	A machine for lifting and lowering the anchor chain
Wing tank	The space bounded by the inner hull longitudinal bulkhead and side shell

2. Structural Idealisation

2.1 Definition of Span

2.1.1 Effective bending span of local support members

2.1.1.1 The effective bending span, l_{bdg} , of a stiffener is defined for typical arrangements in 2.1.1.3 to 2.1.1.7. Where arrangements differ from those shown in Fig. 4.2.1 through Fig. 4.2.8, span definition may be specially considered.

2.1.1.2 The effective bending span may be reduced due to the presence of brackets, provided the brackets are effectively supported by the adjacent structure, otherwise the effective bending span is to be taken as the full length of the stiffener between primary member supports.

2.1.1.3 If the web stiffener is sniped at the end or not attached to the stiffener under consideration, the effective bending span is to be taken as the full length between primary member supports unless a backing bracket is fitted, see Fig. 4.2.2.

2.1.1.4 The effective bending span may only be reduced where brackets are fitted to the flange or free edge of the stiffener. Brackets fitted to the attached plating on the side opposite to that of the stiffener are not to be considered as effective in reducing the effective bending span.

2.1.1.5 The effective bending span, l_{bdg} , for stiffeners forming part of a double skin arrangement is to be taken as shown in Fig. 4.2.1.

2.1.1.6 The effective bending span, l_{bdg} , for stiffeners forming part of a single skin arrangement is to be taken as shown in Fig. 4.2.2.

2.1.1.7 For stiffeners supported by a bracket on one side of primary support members, the effective bending span is to be taken as the full distance between primary support members as shown in Fig. 4.2.2(a). If brackets are fitted on both sides of the primary support member, the effective bending span is to be taken as in Fig. 4.2.2(b), (c) and (d).

Fig. 4.2.1 Effective Bending Span of Stiffeners Supported by Web Stiffeners
(Double Skin Construction)

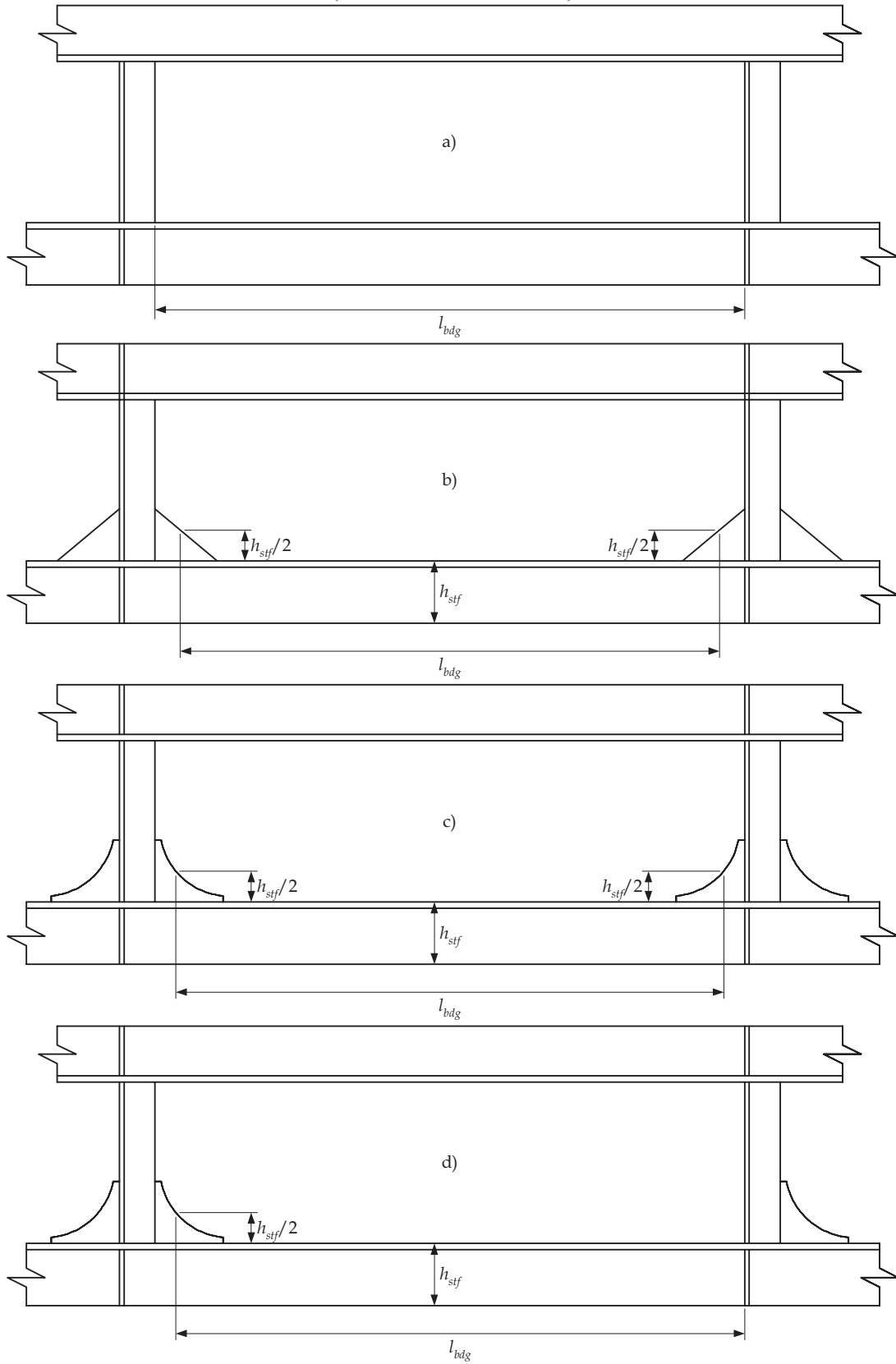
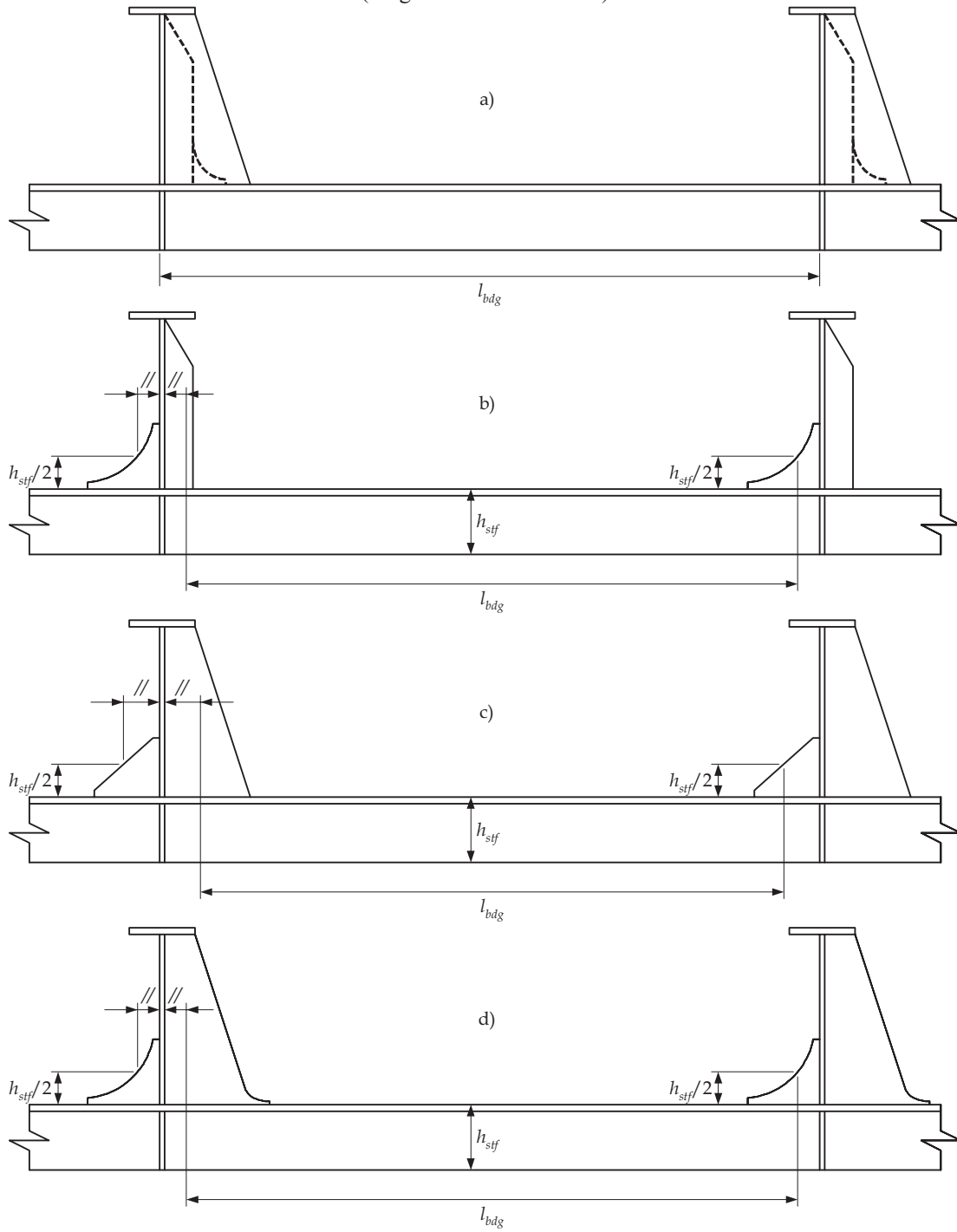
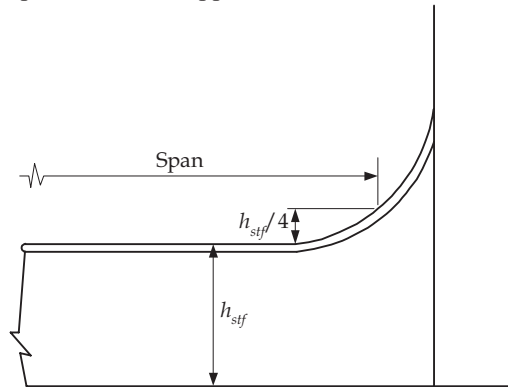

Fig. 4.2.2 Effective Bending Span of Stiffeners Supported by Web Stiffeners
(Single Skin Construction)



2.1.1.8 Where the face plate of the stiffener is continuous along the edge of the bracket, the effective bending span is to be taken to the position where the depth of the bracket is equal to one quarter of the depth of the stiffener, see **Fig. 4.2.3**.

Fig. 4.2.3 Effective Bending Span for Local Support Members with Continuous Face Plate along Bracket Edge



2.1.1.9 For the calculation of the span point, the bracket length is not to be taken greater than 1.5 times the length of the arm on the bulkhead or base.

2.1.2 Effective shear span of local support members

2.1.2.1 The effective shear span, l_{shr} , of a stiffener is defined for typical arrangements in 2.1.2.5 to 2.1.2.7. Effective bending span for other arrangements will be specially considered.

2.1.2.2 The effective shear span may be reduced due to the presence of brackets provided the brackets are effectively supported by the adjacent structure, otherwise the effective shear span is to be as the full length as given in 2.1.2.4.

2.1.2.3 The effective shear span may be reduced for brackets fitted on either the flange or the free edge of the stiffener, or for brackets fitted to the attached plating on the side opposite to that of the stiffener. If brackets are fitted at both the flange or free edge of the stiffener, and to the attached plating on the side opposite to that of the stiffener the effective shear span may be calculated using the longer effective bracket arm.

2.1.2.4 The effective shear span may be reduced by a minimum of $s/4,000$ m at each end of the member, regardless of support detail, hence the effective shear span, l_{shr} , is not to be taken greater than:

$$l_{shr} \leq l - \frac{s}{2000} \quad m$$

Where:

l : full length of the stiffener between primary support members, in m

s : stiffener spacing, in mm , as defined in 2.2.1

2.1.2.5 The effective shear span, l_{shr} , for stiffeners forming part of a double skin arrangement is to be taken as shown in **Fig. 4.2.4**.

2.1.2.6 The effective shear span, l_{shr} , for stiffeners forming part of a single skin arrangement is to be taken as shown in **Fig. 4.2.5**.

Fig. 4.2.4 Effective Shear Span of Stiffeners Supported by Web Stiffeners (Double Skin Construction)

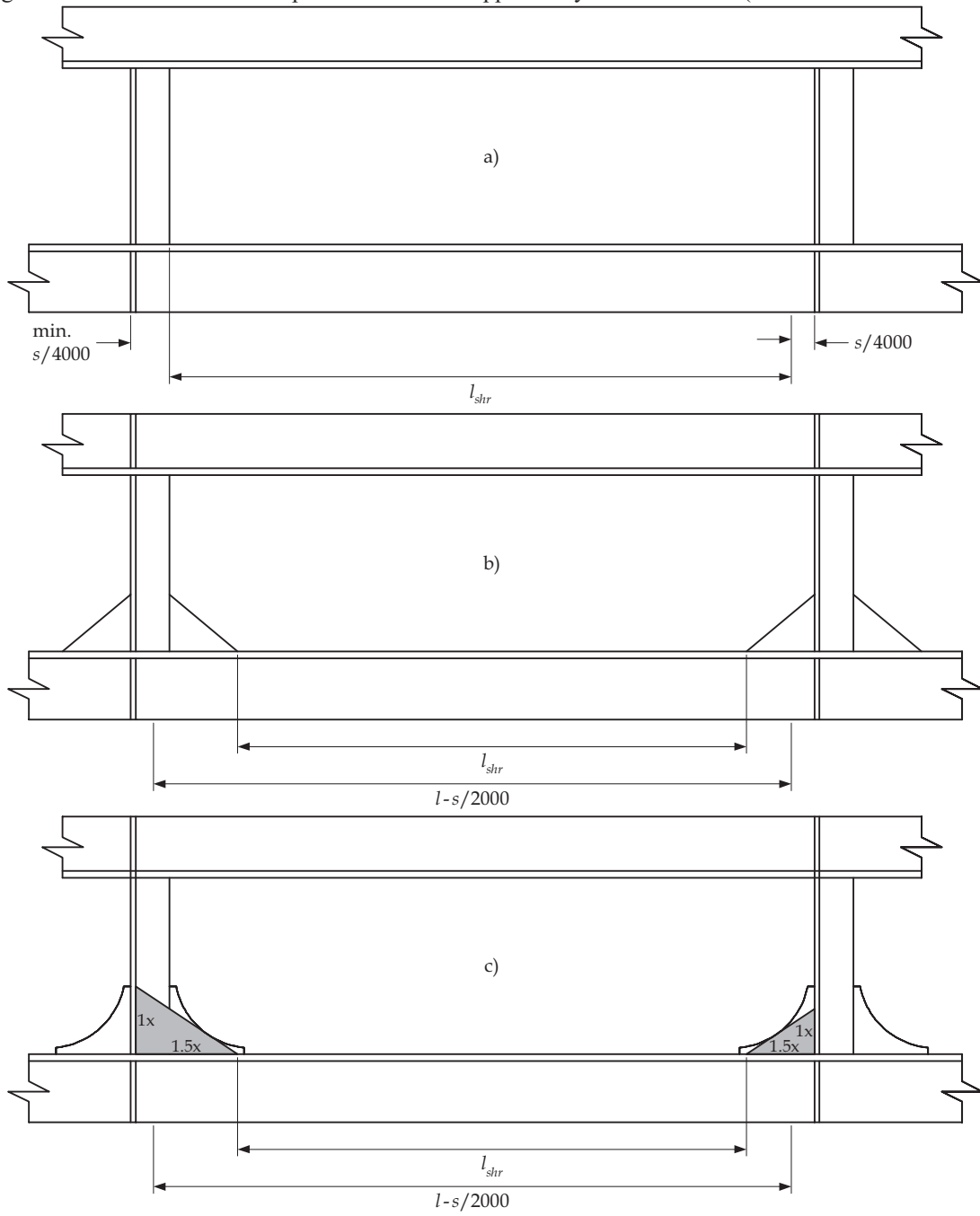

Fig. 4.2.5 Effective Shear Span of Stiffeners Supported by Web Stiffeners (Single Skin Construction)

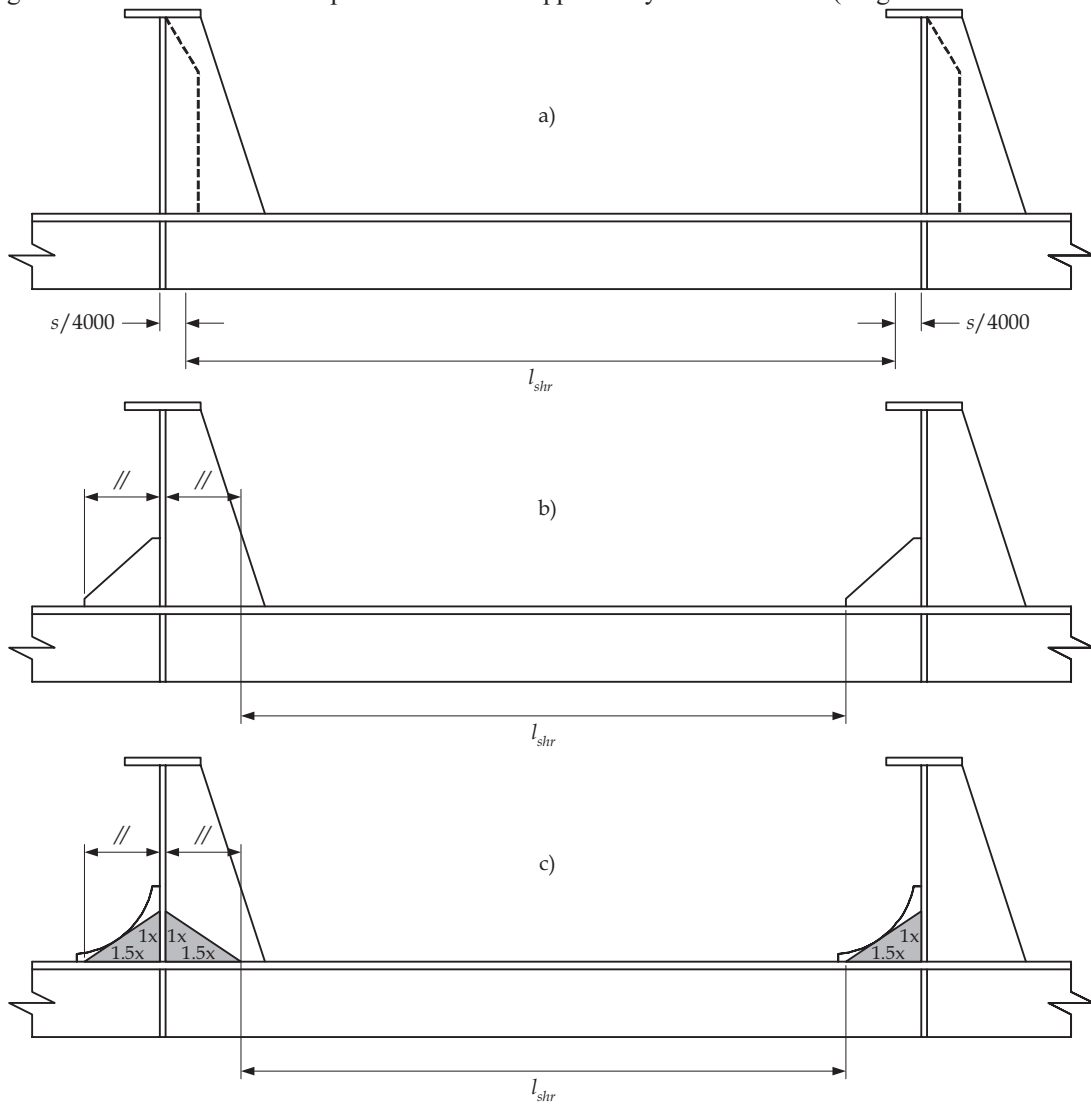
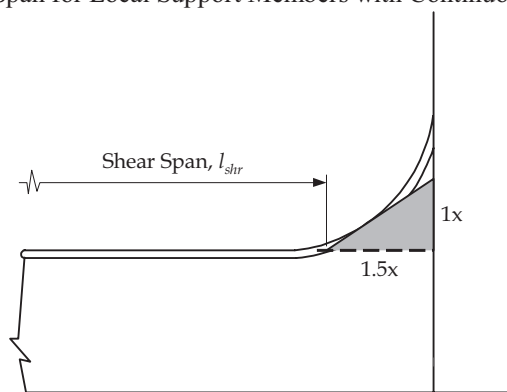

Fig. 4.2.6 Effective Shear Span for Local Support Members with Continuous Face Plate along Bracket Edge



2.1.2.7 Where the face plate of the stiffener is continuous along the curved edge of the bracket, the effective shear span is to be taken as shown in **Fig. 4.2.6**.

2.1.2.8 For curved and/or long brackets (high length/height ratio) the effective bracket length is to be taken as the maximum inscribed 1:1.5 bracket as shown in **Fig. 4.2.4(c)** and **Fig. 4.2.5(c)**.

2.1.3 Effect of hull form shape on span of local support members

2.1.3.1 The full length of the stiffener between primary support members, l , is to be measured along the flange for stiffeners with a flange, and along the free edge for flat bar stiffeners. For curved stiffeners the span is defined as the

chord length between span points. The calculation of the effective span is to be in accordance with requirements given in **2.1.1**.

2.1.4 Effective bending span of primary support members

2.1.4.1 The effective bending span, l_{bdg} , of a primary support member may be taken as less than the full length of the member between supports provided that suitable end brackets are fitted.

2.1.4.2 For arrangements where the primary support member face plate is not carried continuously around the edge of the bracket, i.e. the bracket is welded to the primary support member, the span point at each end of the member, between which the effective bending span is measured, is to be taken at the point where the depth of end bracket measured from the face of the member is equal to one half the depth of the member, as shown in **Fig. 4.2.7(b)**. The effective bracket used to define the span point is to be taken as given in **2.1.4.4**.

2.1.4.3 For brackets where the face plate of the primary support member is continuous along the face of the bracket, i.e. the bracket is integral part of the primary support member, the span point is to be taken at the position where the depth of the bracket is equal to one quarter the depth of the member, see **Fig. 4.2.7(a), (c) and (d)**. The effective bracket used to define the span point is to be taken as given in **2.1.4.4**.

2.1.4.4 The effective bracket is defined as the maximum size of triangular bracket with a length to height ratio of 1.5 that just fits inside the as fitted bracket, for curved brackets the tangent point is to be used to define the fit, see **Fig. 4.2.7** for examples.

2.1.4.5 For straight brackets with a length to height ratio greater than 1.5, the span point is to be taken to the effective bracket; for steeper brackets the span point is to be taken to the as fitted bracket.

2.1.4.6 For curved brackets the span point is to be measured taken to the fitted bracket at span positions above the tangent point between fitted bracket and effective bracket. For span positions below the tangent point the span point is to be measured to the effective bracket.

2.1.4.7 For arrangements where the primary support member face plate is carried on to the bracket and backing brackets are fitted the span point need not be taken greater than to the position where the total depth reaches twice the depth of the primary support member. Arrangements with small and large backing brackets are shown in **Fig. 4.2.7(e) and (f)**.

2.1.4.8 For arrangements where the height of the primary support member is maintained and the face plate width is increased towards the support the effective bending span may be taken to a position where the face plate breadth reaches twice the nominal breadth.

Fig. 4.2.7 Effective Span of Primary Support Member for Bending Assessment

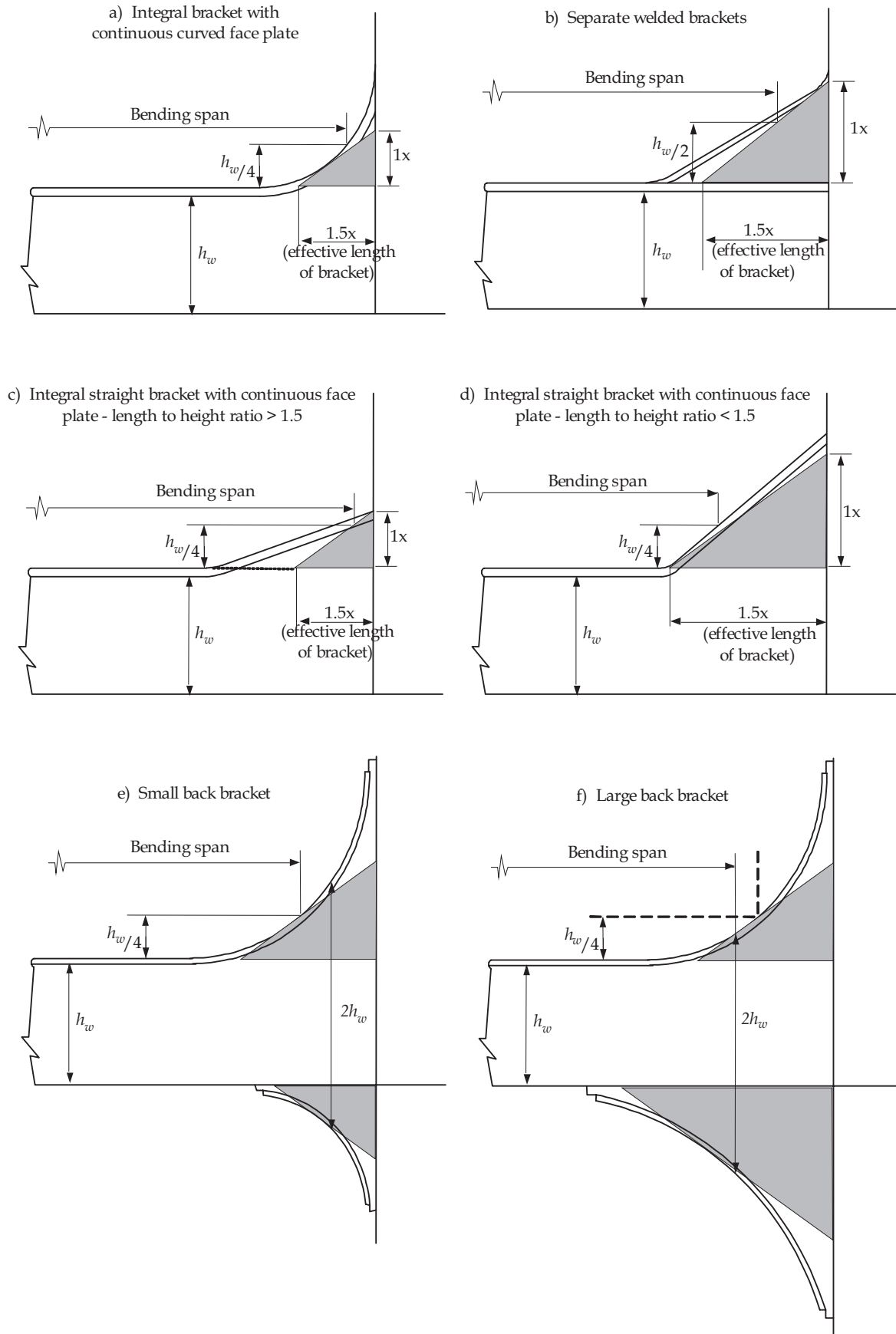

2.1.5 Effective shear span of primary support members

2.1.5.1 The span point at each end of the primary support member, between which the shear span is measured, is to be taken at the toe of the effective brackets supporting the member, where the toes of effective brackets are as shown in **Fig. 4.2.8**. The effective bracket used to define the toe point is given in **2.1.4.4**.

2.1.5.2 For arrangements where the effective backing bracket is larger than the effective bracket in way of face plate, the shear span is to be taken as the mean distance between toes of the effective brackets as shown in **Fig. 4.2.8 (f)**.

Fig. 4.2.8 Effective Span of Primary Support Member for Shear Assessment

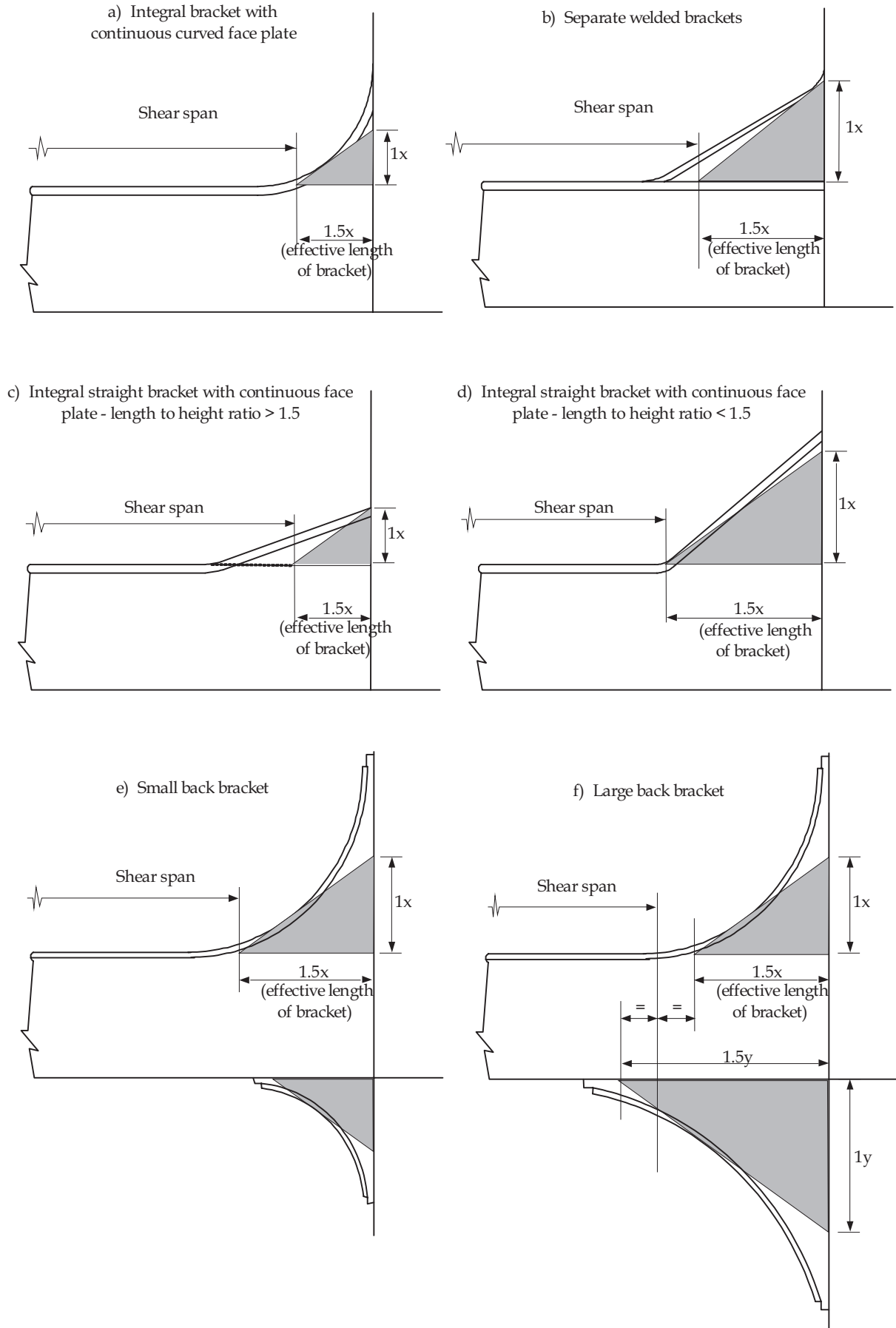

2.2 Definition of Spacing and Supported Breadth

2.2.1 Supported load breadth of local support members

2.2.1.1 The mean of the stiffener spacings on each side is to be used for the calculation of the effective plate flange of stiffeners and the load breadth supported by a stiffener, s , see **Fig. 4.2.9**.

2.2.2 Spacing and supporting load breadth of primary support members

2.2.2.1 Primary support member spacing, S , for the calculation of the effective plate flange of primary support members is to be taken as the mean spacing between adjacent primary support members, as shown in **Fig. 4.2.9**.

2.2.2.2 Unless specifically defined elsewhere in the Rules, the loading breadth supported by a girder is defined as half the sum of the primary support member spacing on each side, see **Fig. 4.2.9**.

2.2.3 Effective spacing of curved plating

2.2.3.1 For curved plating the stiffener spacing or the primary support member spacing, s or S , is to be measured on the mean chord between members.

Fig. 4.2.9 Supported Load Breadth and Breadth of Attached Plating for Local and Primary Support Members

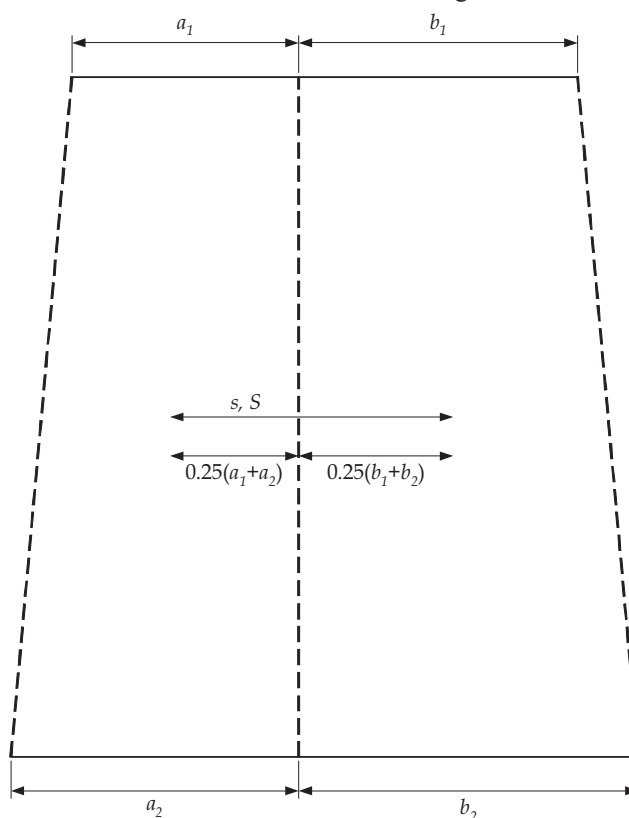

Note

1. The mean breadth is to be taken as $0.25(a_1 + a_2 + b_1 + b_2)$, where a_1, a_2, b_1, b_2 are the spacings between local and primary support members at ends as appropriate.

2.3 Effective Breadth of Plating

2.3.1 Effective breadth of attached plate of local support members for strength evaluation

2.3.1.1 The effective breadth as defined in 2.3.1.2 is applicable to the scantling requirements of stiffeners as given in **Section 8**.

2.3.1.2 The effective breadth of the attached plate, b_{eff} , to be used for calculating the combined section modulus of the stiffener and attached plate is to be taken as the mean stiffener spacing, s , as given in 2.2.1. However, where the attached plate net thickness, t_{p-net} , is less than 8mm, the effective breadth is not to be taken greater than 600mm.

2.3.2 Effective breadth of attached plate and flanges of primary support members for strength evaluation

2.3.2.1 The effective breadths as defined in 2.3.2.2 to 2.3.2.4 are applicable to the scantling requirements of primary support members as given in Section 8.

2.3.2.2 At the end of the span where no effective end bracket is fitted, the effective breadth of attached plate, b_{eff} , for calculating the section modulus and/or moment of inertia of a primary support member is to be taken as:

$$b_{eff} = 0.67 S \sin \left[\frac{\pi}{6} \left(\frac{l_{bdg} \left(1 - \frac{1}{\sqrt{3}}\right)}{2S} \right) \right] \quad (m) \quad \text{for} \quad \left(\frac{l_{bdg} \left(1 - \frac{1}{\sqrt{3}}\right)}{2S} \right) \leq 3$$

$$b_{eff} = 0.67S \quad (m) \quad \text{for} \quad \left(\frac{l_{bdg} \left(1 - \frac{1}{\sqrt{3}}\right)}{2S} \right) > 3$$

Where:

S : mean spacing of primary support member as defined in 2.2.2 at position considered, in m

l_{bdg} : effective bending span, as defined in 2.1.4, in m

Note : $\sin()$ is to be calculated in *radians*

2.3.2.3 At mid span, the effective breadth of attached plate, b_{eff} , for calculating the section modulus and/or moment of inertia of a primary support member is to be taken as:

$$b_{eff} = S \sin \left[\frac{\pi}{18} \left(\frac{l_{bdg}}{S\sqrt{3}} \right) \right] \quad (m) \quad \text{for} \quad \left(\frac{l_{bdg}}{S\sqrt{3}} \right) \leq 9$$

$$b_{eff} = 1.0S \quad (m) \quad \text{for} \quad \left(\frac{l_{bdg}}{S\sqrt{3}} \right) > 9$$

Where:

S : mean spacing of primary support member as defined in 2.2.2 at position considered, in m

l_{bdg} : effective bending span, as defined in 2.1.4, in m

Note : $\sin()$ is to be calculated in *radians*

2.3.2.4 At the end of the span where an effective end bracket is fitted, the effective breadth of attached plate, b_{eff} , for calculating the section modulus of a primary support member is to be taken as the mean values of those given by 2.3.2.2 and 2.3.2.3. A bracket is considered effective when the length as defined in Fig. 4.2.7 is equal or greater than $0.1l_{bdg}$.

2.3.2.5 The free flange of primary support members of single skin construction may generally be considered fully effective provided tripping bracket arrangements are fitted as required in Section 10/2.3.3. For curved face plates see 2.3.4.

2.3.3 Effective breadth of attached plate of local support members for fatigue strength evaluation

2.3.3.1 The effective breadths as defined in 2.3.3.2 and 2.3.3.3 are applicable to the fatigue strength evaluation of local support members as given in Section 9/3 and Appendix C.

2.3.3.2 At the ends of the span and in way of end brackets and supports, the effective breadth of attached plating, b_{eff} , to be used for calculating the combined section modulus of the stiffener and attached plate is to be taken as:

$$b_{eff} = 0.67s \sin \left[\frac{\pi}{6} \left(\frac{l_{bdg} \left(1 - \frac{1}{\sqrt{3}}\right)}{2s} \right) \right] \quad (mm) \quad \text{for} \quad \left(\frac{1000l_{bdg} \left(1 - \frac{1}{\sqrt{3}}\right)}{2s} \right) \leq 3$$

$$b_{eff} = 0.67s \quad (mm) \quad \text{for} \quad \left(\frac{1000l_{bdg} \left(1 - \frac{1}{\sqrt{3}}\right)}{2s} \right) > 3$$

Where:

s : stiffener spacing, in mm , as defined in 2.2.1

l_{bdg} : effective bending span, as defined in 2.1.1, in m

Note : $\sin()$ is to be calculated in *radians*

2.3.3.3 At mid span, the effective breadth of attached plate, b_{eff} , to be used for calculating the combined section modulus of the stiffener and attached plate is to be taken as:

$$b_{eff} = s \sin \left[\frac{\pi}{18} \left(\frac{1000 l_{bdg}}{s \sqrt{3}} \right) \right] \quad (mm) \quad \text{for } \left(\frac{1000 l_{bdg}}{s \sqrt{3}} \right) \leq 9$$

$$b_{eff} = 1.0 s \quad (mm) \quad \text{for } \left(\frac{1000 l_{bdg}}{s \sqrt{3}} \right) > 9$$

Where:

s : stiffener spacing, in mm , as defined in 2.2.1

l_{bdg} : effective bending span, as defined in 2.1.1, in m

Note : $\sin()$ is to be calculated in *radians*

2.3.4 Effective area of curved face plates or attached plating of primary support members

2.3.4.1 The effective area as defined in 2.3.4.2 and 2.3.4.3 is applicable to primary support members as follows:

- deriving the effective net area of curved face plates and curved attached plating for calculating the section modulus of primary support members for the scantling requirements in **Section 8**
- deriving the effective net area of curved face plates, modelled by beam elements, for the strength assessment (*FEM*) in **Section 9/2** and **Appendix B**

2.3.4.2 The effective net area of curved face plates or attached plating of primary support members, $A_{eff-net50}$, is to be taken as:

$$A_{eff-net50} = C_f t_{f-net50} b_f \quad (mm^2)$$

Where:

C_f : flange efficiency coefficient as shown in **Fig. 4.2.10**

$$= C_{f1} \frac{\sqrt{r_f t_{f-net50}}}{b_1} \quad \text{but not to be taken greater than 1.0}$$

$$C_{f1} = \frac{0.643 (\sinh \beta \cosh \beta + \sin \beta \cos \beta)}{\sinh^2 \beta + \sin^2 \beta} \quad \text{for symmetrical and unsymmetrical}$$

face plates, see *Curve 1* in **Fig. 4.2.10**

$$= \frac{0.78 (\sinh \beta + \sin \beta) (\cosh \beta - \cos \beta)}{\sinh^2 \beta + \sin^2 \beta} \quad \text{for attached plating of box girders}$$

with two webs, see *Curve 2* in **Fig. 4.2.10**

$$= \frac{1.56 (\cosh \beta - \cos \beta)}{\sinh \beta + \sin \beta} \quad \text{for attached plating of box girders with multiple}$$

webs, see *Curve 3* in **Fig. 4.2.10**

$$\beta = \frac{1.285 b_1}{\sqrt{r_f t_{f-net50}}} \quad (rad)$$

$$b_1 = 0.5 (b_f - t_{w-net50}) \quad \text{for symmetrical face plates}$$

$$= b_f \quad \text{for unsymmetrical face plates}$$

$$= s_w - t_{w-net50} \quad \text{for attached plating of box girders}$$

s_w : spacing of supporting webs for box girders, in mm

$t_{f-net50}$: net flange thickness

$$= t_{f-grs} - 0.5 t_{corr} \quad (mm)$$

for calculation of C_f and β for unsymmetrical face plates $t_{f-net50}$ is not to be taken greater than $t_{w-net50}$

t_{f-grs} : gross flange thickness, in mm

$t_{w-net50}$: net web plate thickness

$$= t_{w-grs} - 0.5 t_{corr} \quad (mm)$$

- t_{w-grs} : gross web thickness, in *mm*
- t_{corr} : corrosion addition, as given in **Section 6/3.2**
- r_f : radius of curved face plate or attached plating, in *mm*
- b_f : breadth of face plate or attached plating, in *mm*

2.3.4.3 The effective net area of curved face plates supported by radial brackets, or attached plating supported by cylindrical stiffeners, $A_{eff-net50}$, is given by:

$$A_{eff-net50} = \left(\frac{3r_f t_{f-net50} + C_f s_r^2}{3r_f t_{f-net50} + s_r^2} \right) t_{f-net50} b_f \quad (mm^2)$$

Where:

- C_f : as defined in **2.3.4.2**
- $t_{f-net50}$: net flange thickness, as defined in **2.3.4.2**
- s_r : spacing of tripping brackets or web stiffeners or stiffeners normal to the web plating, in *mm*, see **Fig. 4.2.11**
- b_f : breadth of face plate or attached plating, in *mm*, see **Fig. 4.2.11**
- r_f : radius of curved face plate or attached plating, in *mm*, see **Fig. 4.2.11**

Fig. 4.2.10 Effective Width of Curved Face Plates for Alternative Structural Configurations

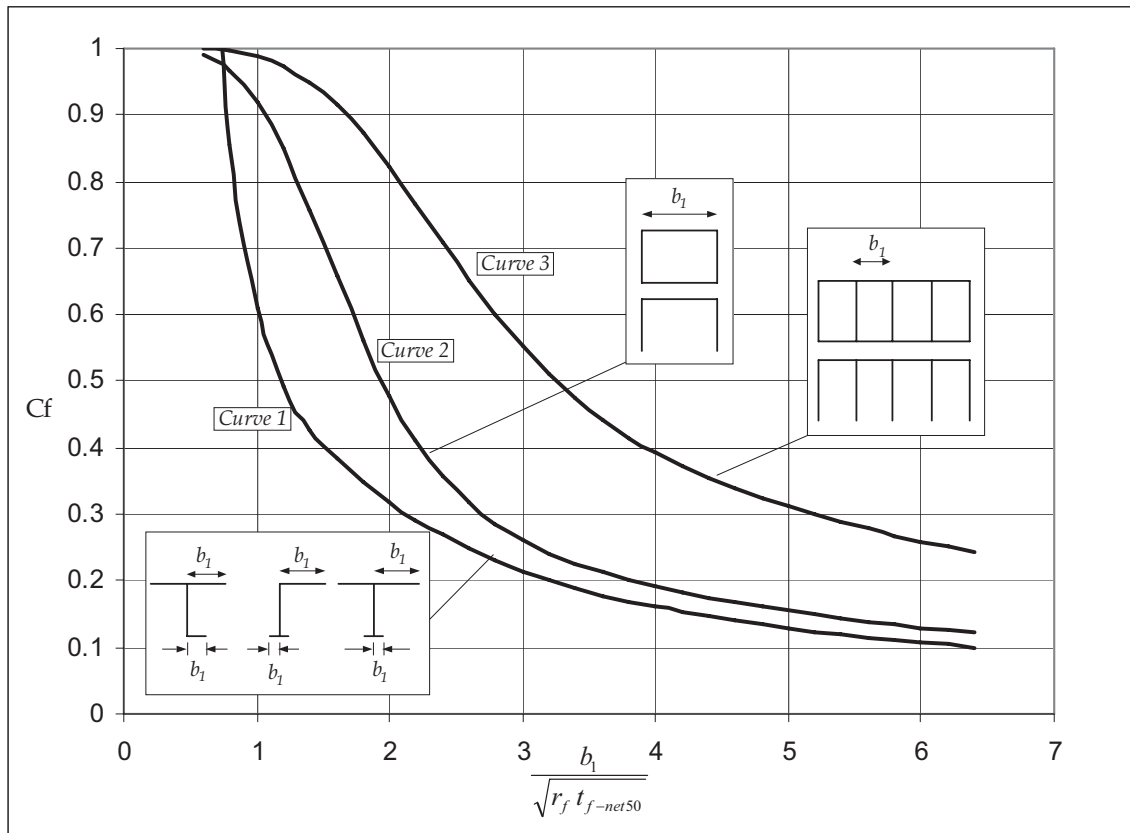

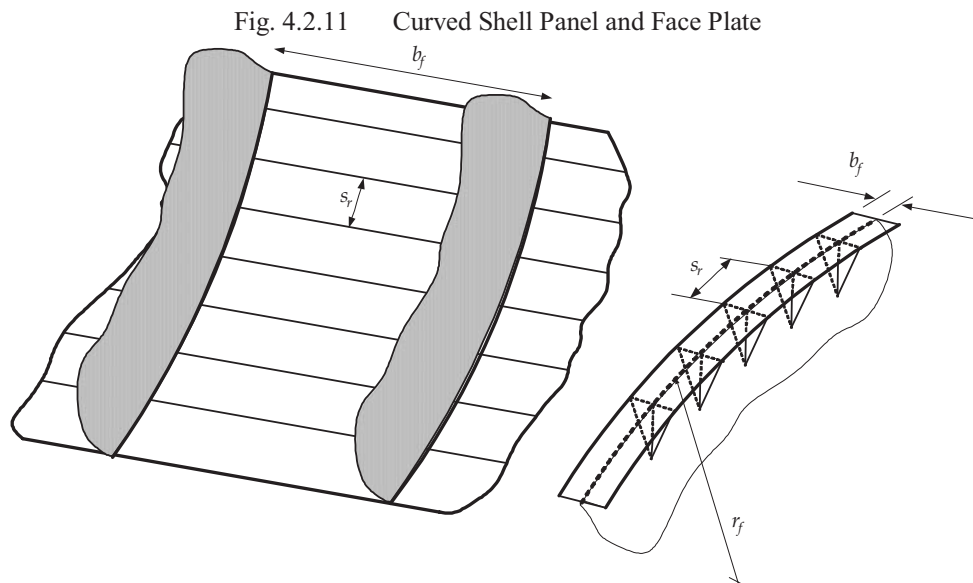

2.3.4.4 The effective area given in 2.3.4.2 and 2.3.4.3 is only applicable to faceplates and attached plating of primary support members. This is not to be applied for the area of web stiffeners parallel to the face plate.

2.4 Geometrical Properties of Local Support Members

2.4.1 Calculation of net section properties for local support members

2.4.1.1 The net section modulus, moment of inertia and shear area properties of local support members are to be calculated using the net thicknesses of the attached plate, web and flange.

2.4.1.2 The description of the net dimensions for typical profiles is given in Fig. 4.2.12.

Fig. 4.2.12 Net Sectional Properties of Local Support Members

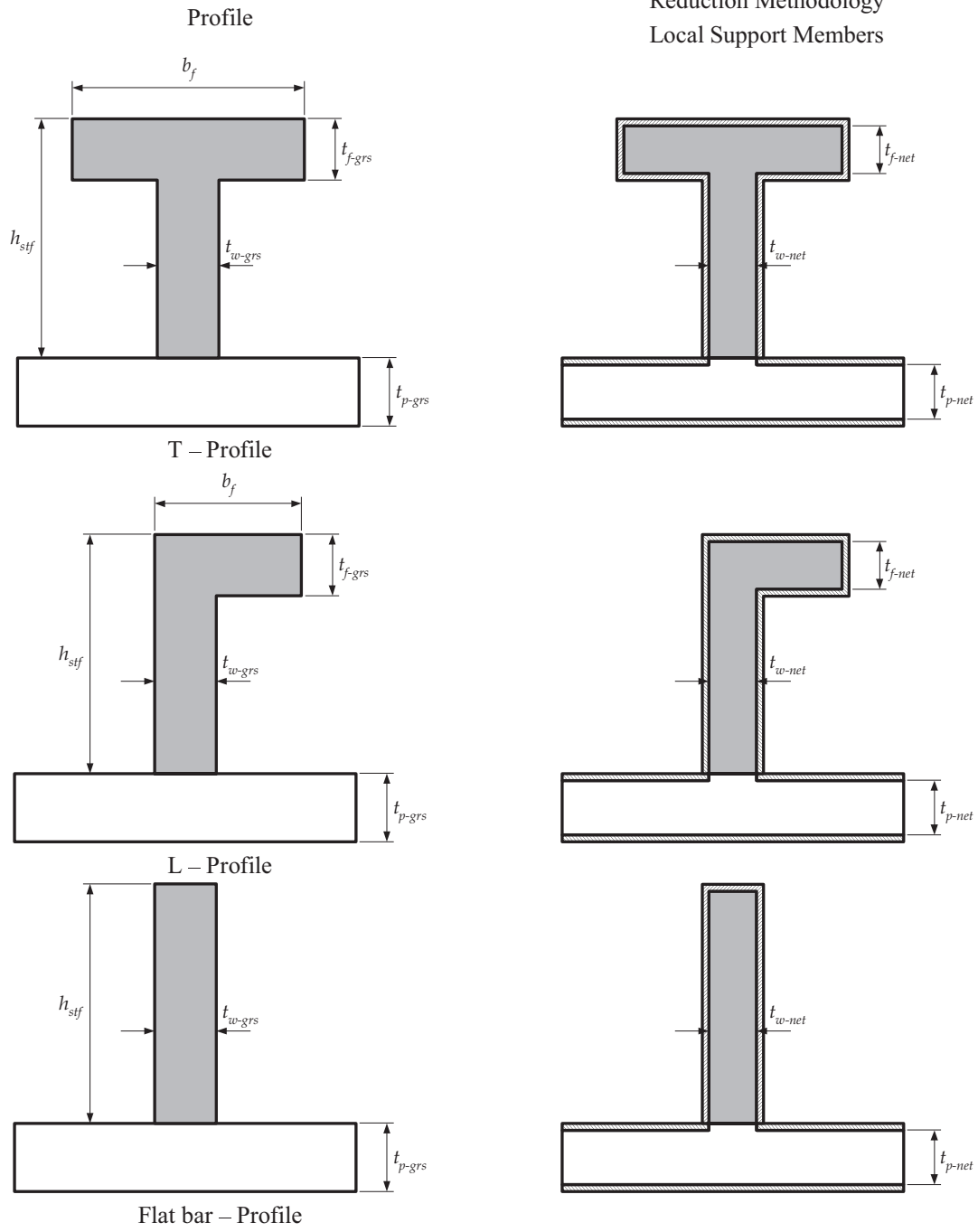
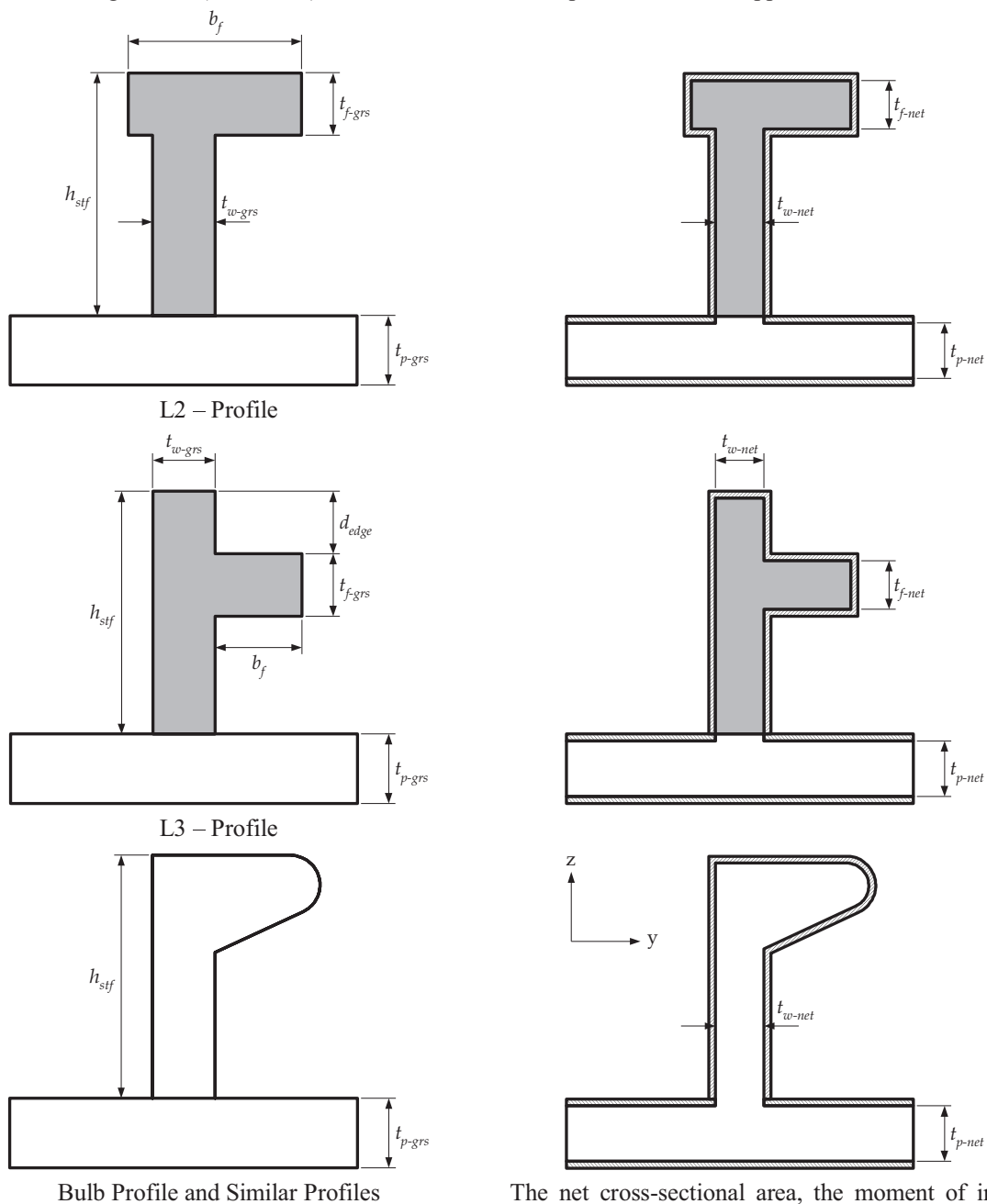

Fig. 4.2.12 (Continued) Net Sectional Properties of Local Support Members



The net cross-sectional area, the moment of inertia about the y -axis and the associated neutral axis position of the profile is to be determined assuming the corrosion magnitude $0.5t_{corr}$ deducted from the surface of the profile cross-section

2.4.2 Effective elastic sectional properties of local support members

2.4.2.1 The net elastic shear area, $A_{shr-el-net}$, of local support members is to be taken as:

$$A_{shr-el-net} = \frac{(h_{stf} + t_{p-net}) t_{w-net} \sin \varphi_w}{100} \quad (cm^2)$$

Where:

h_{stf} : stiffener height, including face plate, in *mm*. See also **2.4.1.2**

t_{p-net} : net thickness of attached plate, in *mm*

t_{w-net} : net web thickness, in *mm*

φ_w : angle between the stiffener web and attached plating, see **Fig. 4.2.14**, in *degrees*. φ_w is to be taken as 90 *degrees* if the angle is greater than or equal to 75 *degrees*

2.4.2.2 The effective shear depth of stiffeners, d_{shr} , is to be taken as:

$$d_{shr} = (h_{stf} + t_{p-net}) \sin \varphi_w \quad (mm)$$

Where:

h_{stf} : stiffener height, including face plate, in *mm*. See also **2.4.1.2**

t_{p-net} : net thickness of attached plate, in *mm*

φ_w : angle between the stiffener web and attached plating, see **Fig. 4.2.14**, in *degrees*. φ_w is to be taken as 90 *degrees* if the angle is greater than or equal to 75 *degrees*

2.4.2.3 The elastic net section modulus, $Z_{el-\varphi-net}$ of local support members is to be taken as:

$$Z_{el-\varphi-net} = Z_{stf-net} \sin \varphi_w \quad (cm^3)$$

Where:

$Z_{stf-net}$: net section modulus of corresponding upright stiffener, i.e. when φ_w is equal to 90 *degrees*, in cm^3 . See also **2.4.1.2**

φ_w : angle between the stiffener web and attached plating, see **Fig. 4.2.14**, in *degrees*. φ_w is to be taken as 90 *degrees* if the angle is greater than or equal to 75 *degrees*

2.4.3 Effective plastic section modulus and shear area of stiffeners

2.4.3.1 The net plastic shear area, $A_{shr-pl-net}$, of local support members is to be taken as:

$$A_{shr-pl-net} = \frac{(h_{stf} + t_{p-net}) t_{w-net} \sin \varphi_w}{100} \quad (cm^2)$$

Where:

h_{stf} : stiffener height, including face plate, in *mm*. See also **2.4.1.2**

t_{p-net} : net thickness of attached plate, in *mm*

t_{w-net} : net web thickness, in *mm*

φ_w : angle between the stiffener web and the plate flange, see **Fig. 4.2.14**, in *degrees*. φ_w is to be taken as 90 *degrees* if the angle is greater than or equal to 75 *degrees*

Fig. 4.2.14 Angle between Stiffener Web and Plate Flange

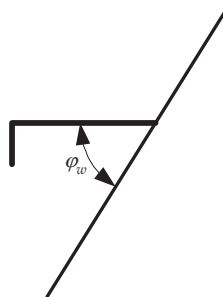

2.4.3.2 The effective net plastic section modulus, Z_{pl-net} , of local support members is to be taken as:

$$Z_{pl-net} = \frac{f_w d_w^2 t_{w-net} \sin \varphi_w}{2000} + \frac{(2\gamma - 1) A_{f-net} (h_{f-ctr} \sin \varphi_w - b_{f-ctr} \cos \varphi_w)}{1000} \quad (cm^3)$$

Where:

f_w : web shear stress factor

= 0.75 for flanged profile cross-sections with $n = 1$ or 2

= 1.0 for flanged profile cross-sections with $n = 0$ and for flat bar stiffeners

n : number of moment effective end supports of each member = 0, 1 or 2

A moment effective end support may be considered where:

(a) the stiffener is continuous at the support

(b) the stiffener passes through the support plate while it is connected at its termination point by a carling (or equivalent) to adjacent stiffeners

(c) the stiffener is attached to an abutting stiffener effective in bending (not a buckling stiffener) or bracket. The bracket is assumed to be bending effective when it is attached to another stiffener (not a buckling stiffener).

d_w : depth of stiffener web, in mm

= $h_{stf} - t_{f-net}$ for T, L (rolled and built up) and L2 profiles

= h_{stf} for flat bar and L3 profiles

to be taken as given in **Table 4.2.3** and **Table 4.2.4** for bulb profiles

h_{stf} : stiffener height, in mm , see **Fig. 4.2.12**

γ = $0.25 \left(1 + \sqrt{3 + 12\beta} \right)$

β = 0.5 for all cases, except L profiles without a mid span tripping bracket

$$= \frac{10^6 t_{w-net}^2 f_b l_f^2}{80 b_f^2 t_{f-net} h_{f-ctr}} + \frac{t_{w-net}}{2 b_f}$$

but not to be taken greater than 0.5 for L (rolled and built-up) profiles without a mid span tripping bracket

A_{f-net} : net cross-sectional area of flange, in mm^2

= $b_f t_{f-net}$ in general

= 0 for flat bar stiffeners

b_f : breadth of flange, in mm , see **Fig. 4.2.12**. For bulb profiles, see **Table 4.2.3** and **Table 4.2.4**

b_{f-ctr} : distance from mid thickness of stiffener web to the centre of the flange area

= $0.5(b_f - t_{w-grs})$ for rolled angle profiles

= 0 for T profiles

as given in **Table 4.2.3** and **Table 4.2.4** for bulb profiles

h_{f-ctr} : height of stiffener measured to the mid thickness of the flange

= $h_{stf} - 0.5 t_{f-net}$ for profiles with flange of rectangular shape except for L3 profiles

= $h_{stf} - d_{edge} - 0.5 t_{f-net}$ for L3 profiles

as given in **Table 4.2.3** and **4.2.4** for bulb profiles

d_{edge} : distance from upper edge of web to the top of the flange, in mm . For L3 profiles, see

Fig. 4.2.12

f_b = 1.0 in general

= 0.8 for continuous flanges with end bracket(s). A continuous flange is defined as a flange that is not sniped and continuous through the primary support member

= 0.7 for non-continuous flanges with end bracket(s). A non-continuous flange is defined as a flange that is sniped at the primary support member or terminated at the support without aligned structure on the other side of the support

l_f : length of stiffener flange between supporting webs, in m , but reduced by the arm length of end bracket(s) for stiffeners with end bracket(s) fitted

- t_{f-net} : net flange thickness, in *mm*
 = 0 for flat bar stiffeners
 given in **Table 4.2.3** and **Table 4.2.4** for bulb profiles
- t_{w-net} : net web thickness, in *mm*
- φ_w : angle between the stiffener web and the plate flange, see **Fig. 4.2.14**, in *degrees*. φ_w is to be taken as 90 *degrees* if the angle is greater than or equal to 75 *degrees*

Table 4.2.3 Characteristic Flange Data for *HP* Bulb Profiles (see **Fig. 4.2.15**)

h_{stf} (<i>mm</i>)	d_w (<i>mm</i>)	b_{f-grs}^* (<i>mm</i>)	t_{f-grs}^* (<i>mm</i>)	b_{f-ctr} (<i>mm</i>)	h_{f-ctr} (<i>mm</i>)
200	171	40	14.4	10.9	188
220	188	44	16.2	12.1	206
240	205	49	17.7	13.3	225
260	221	53	19.5	14.5	244
280	238	57	21.3	15.8	263
300	255	62	22.8	16.9	281
320	271	65	25.0	18.1	300
340	288	70	26.4	19.3	318
370	313	77	28.8	21.1	346
400	338	83	31.5	22.9	374
430	363	90	33.9	24.7	402

Note

1. Characteristic flange data converted to net scantlings are given as:

$$b_f \cong b_{f-grs}^* + 2 t_{w-net}$$

$$t_{f-net} = t_{f-grs}^* - t_{corr}$$

$$t_{w-net} = t_{w-grs} - t_{corr}$$

Table 4.2.4 Characteristic Flange Data for *JIS* Bulb Profiles (see **Fig. 4.2.15**)

h_{stf} (<i>mm</i>)	d_w (<i>mm</i>)	b_{f-grs}^* (<i>mm</i>)	t_{f-grs}^* (<i>mm</i>)	b_{f-ctr} (<i>mm</i>)	h_{f-ctr} (<i>mm</i>)
180	156	34	11.9	9.0	170
200	172	39	13.7	10.4	188
230	198	45	15.2	11.7	217
250	215	49	17.1	12.9	235

Note

1. Characteristic flange data converted to net scantlings are given as:

$$b_f \cong b_{f-grs}^* + 2 t_{w-net}$$

$$t_{f-net} = t_{f-grs}^* - t_{corr}$$

$$t_{w-net} = t_{w-grs} - t_{corr}$$

Fig. 4.2.15 Characteristic Data for Bulb Profiles

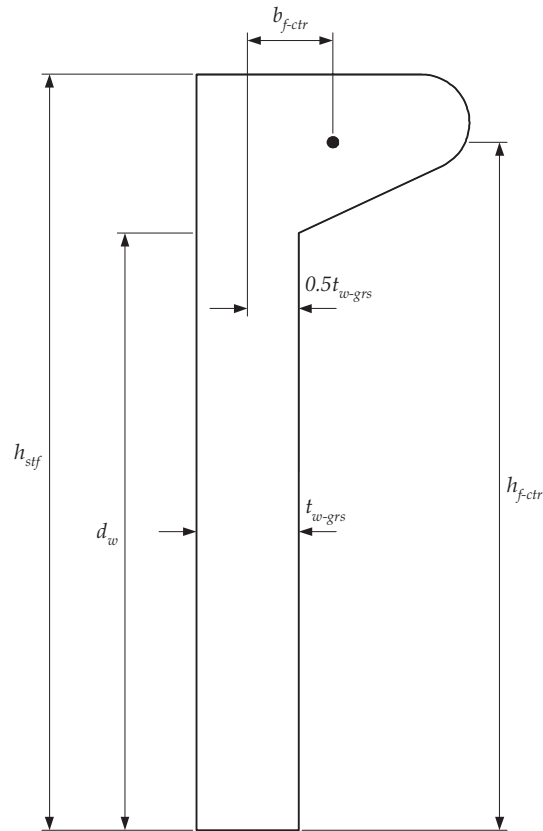

2.5 Geometrical Properties of Primary Support Members

2.5.1 Effective shear area of primary support members

2.5.1.1 For calculation of the shear area of primary support members the web height, h_w , is to be taken as the moulded height of the primary support member.

2.5.1.2 For single and double skin primary support members, the effective net shear area, $A_{shr-net50}$, is to be taken as:

$$A_{shr-net50} = 0.01 h_n t_{w-net50} \sin \varphi_w \quad (cm^2)$$

Where:

h_n : for a single skin primary support member, see **Fig. 4.2.16**, the effective web height, in *mm*, is to be taken as the lesser of

- (a) h_w
- (b) $h_{n3} + h_{n4}$
- (c) $h_{n1} + h_{n2} + h_{n4}$

: for a double skin primary support member, the same principle is to be adopted in determining the effective web height.

h_w : web height of primary support member, in *mm*

$h_{n1}, h_{n2}, h_{n3}, h_{n4}$: as shown in **Fig. 4.2.16**

$t_{w-net50}$: net web thickness
 $= t_{w-grs} - 0.5 t_{corr}$ (mm)

t_{w-grs} : gross web thickness, in *mm*

t_{corr} : corrosion addition, as given in **Section 6/3.2**, in *mm*

φ_w : angle between the web and attached plating, see **Fig.4.2.14**, in *degrees*.
 φ_w is to be taken as 90 *degrees* if the angle is greater than or equal to 75 *degrees*

Fig. 4.2.16 Effective Shear Area in way of Openings

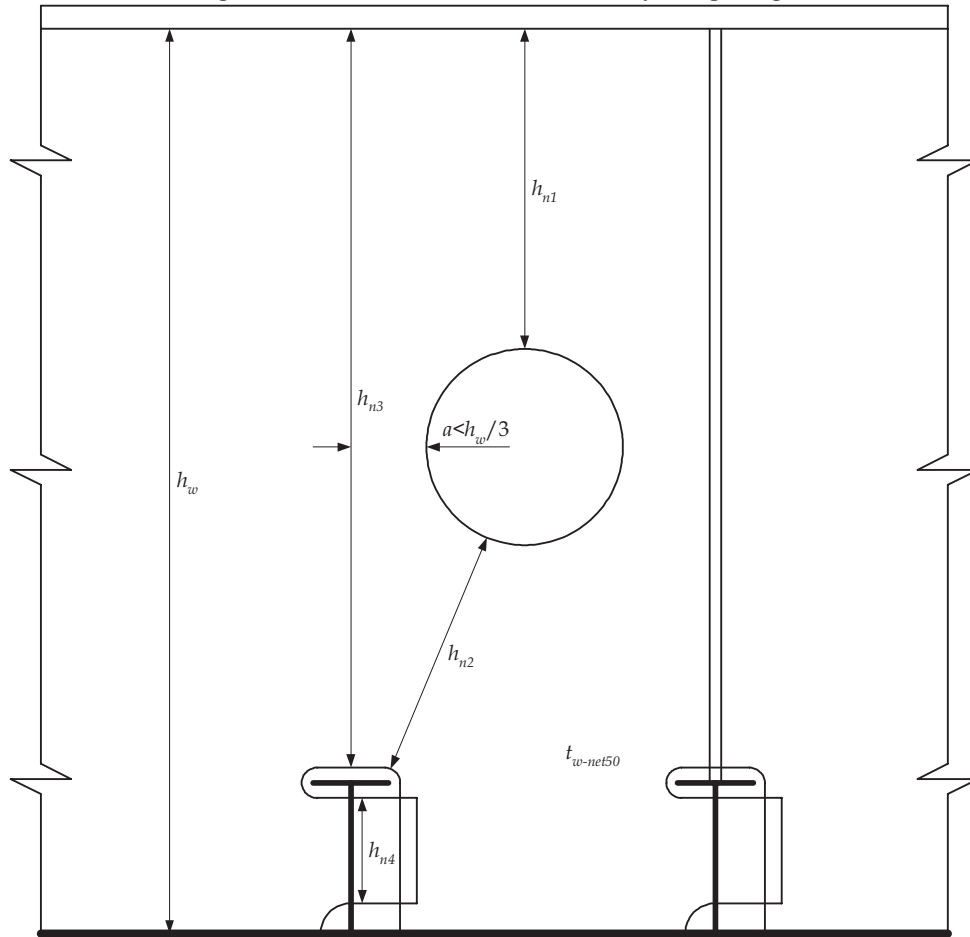

Note :

The figure shows effective web height for a single skin primary support member. The effective web height of a double skin primary support member follows the same principles.

2.5.1.3 Where an opening is located at a distance less than $h_w/3$ from the cross-section considered, h_n is to be taken as the smaller of the net height and the net distance through the opening. See **Fig. 4.2.16**.

2.5.1.4 Where a girder flange of a single skin primary support member is not parallel to the axis of the attached plating, the effective net shear area, $A_{shr-net50}$, is to be taken as:

$$A_{shr-net50} = 0.01 h_n t_{w-net50} + 1.3 A_{f-net50} \sin 2\theta \sin \theta \quad (cm^2)$$

Where:

$A_{f-net50}$: net flange/face plate area
 $= 0.01 b_f t_{f-net50} \quad (cm^2)$

b_f : breadth of flange or face plate, in *mm*

$t_{f-net50}$: net flange thickness
 $= t_{f-grs} - 0.5t_{corr} \quad (mm)$

t_{f-grs} : gross flange thickness, in *mm*

t_{corr} : corrosion addition, as given in **Section 6/3.2**, in *mm*

θ : angle of slope of continuous flange, see **Fig. 4.2.17**

$t_{w-net50}$: net web thickness, as defined in **2.5.1.2**, in *mm*

h_n : effective web height, as defined in **Fig. 4.2.16**, in *mm*

Fig. 4.2.17 Effective Shear Area in way of Brackets

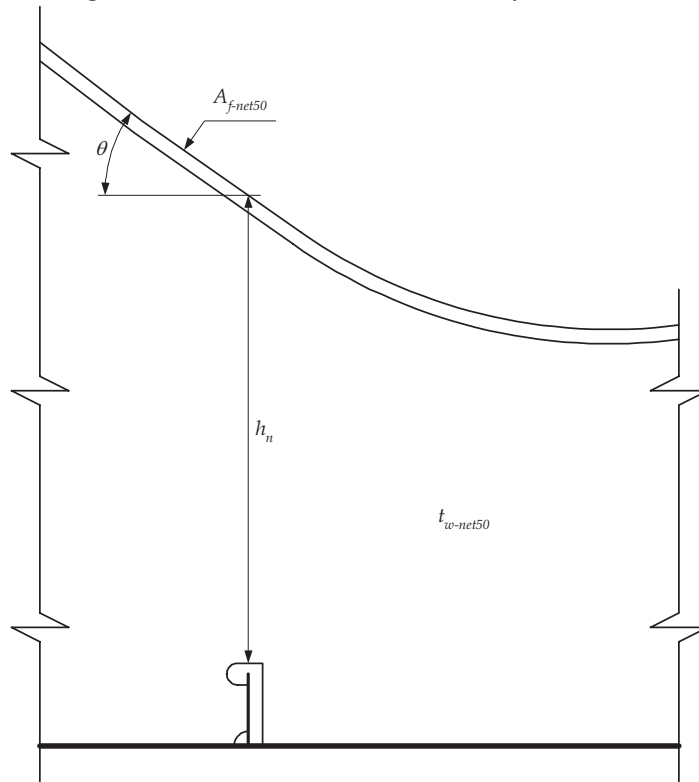

2.5.2 Effective section modulus of primary support members

2.5.2.1 The net section modulus of primary support members is to be calculated using the net thicknesses of the attached plate, web and face plate (or top attached plate for double skin girders), where the net thicknesses are to be taken as:

$$t_{w-net50} = t_{w-grs} - 0.5t_{corr} \quad \text{mm, for the net web thickness}$$

$$t_{p-net50} = t_{p-grs} - 0.5t_{corr} \quad \text{mm, for the net lower attached plate thickness}$$

$$t_{f-net50} = t_{f-grs} - 0.5t_{corr} \quad \text{mm, for the net upper attached plate or face plate}$$

Where:

t_{w-grs} : gross web thickness, in mm

t_{p-grs} : gross thickness of lower attached plate, in mm

t_{f-grs} : gross thickness of upper attached plate or face plate, in mm

t_{corr} : corrosion addition, as given in **Section 6/3.2**, in mm

Note :

See **2.3.4** for curved face plates of primary support members

Where angle between the primary support member web and the plate flange is less than 75 degrees, the section modulus is to be directly calculated.

2.6 Geometrical Properties of the Hull Girder Cross-Section

2.6.1 Vertical hull girder section modulus

2.6.1.1 The effective vertical hull girder section modulus, Z_v , at any vertical distance, z , above the baseline is defined by:

$$Z_v = \frac{I_v}{|z - z_{NA}|} \quad (m^3)$$

where:

I_v : vertical hull girder moment of inertia, of all longitudinally continuous members in cross section under consideration, after deduction of openings as given in **2.6.3**, in m^4

z : distance from the structural member under consideration to the baseline, in m

z_{NA} : distance from the baseline to the horizontal neutral axis of the hull girder cross-section, in m

2.6.1.2 For calculation of the vertical net hull girder section modulus for the strength assessment, $Z_{v-net50}$, required by **Section 8**, the vertical net hull girder moment of inertia and position of horizontal neutral axis is to be calculated based on gross thickness minus the corrosion addition $0.5t_{corr}$ of all effective structural members comprising the hull girder section, where t_{corr} is as defined in **Section 6/3.2**.

2.6.1.3 For calculation of vertical net hull girder section modulus for the fatigue assessment, $Z_{v-net75}$, required by **Section 9/3**, the vertical net hull girder moment of inertia and position of horizontal neutral axis is to be calculated based on gross thickness minus the corrosion addition $0.25t_{corr}$ of all effective structural members comprising the hull girder section, where t_{corr} is as defined in **Section 6/3.2**.

2.6.2 Horizontal hull girder section modulus

2.6.2.1 The effective horizontal hull girder section modulus, Z_h , at any transverse coordinate, y , is to be taken as:

$$Z_h = \frac{I_h}{|y - y_{NA}|} \quad (m^3)$$

where:

- I_h : horizontal hull girder moment of inertia, of all longitudinally continuous members in cross section under consideration, after deduction of openings as given in **2.6.3**, in m^4
- y : transverse coordinate, in m
- y_{NA} : distance from the centreline to the vertical neutral axis of the hull girder cross section, in m

2.6.2.2 For calculation of the horizontal net hull girder section modulus for the strength assessment, $Z_{h-net50}$, required by **Section 8**, the horizontal net hull girder moment of inertia and position of vertical neutral axis is to be calculated based on gross thickness minus the corrosion addition $0.5t_{corr}$ of all effective structural members comprising the hull girder section, where t_{corr} is as defined in **Section 6/3.2**.

2.6.2.3 For calculation of the horizontal net hull girder section modulus for fatigue assessment, $Z_{h-net75}$, as required in **Section 9/3**, the net horizontal hull girder moment of inertia and position of vertical neutral axis is to be calculated based on gross thickness minus the corrosion addition $0.25t_{corr}$ of all effective structural members comprising the hull girder section, where t_{corr} is as defined in **Section 6/3.2**.

2.6.3 Effective area for calculation of hull girder moment of inertia and section modulus

2.6.3.1 The effective hull girder sectional area includes all the longitudinally continuous structural members after deduction of openings. The structural members given in **2.6.3.2** are not to be included in the effective hull girder sectional area. The definition of openings to be deducted and deduction free openings are given in **2.6.3.4 – 2.6.3.9**. The definition of effective area in way of non-continuous bulkheads and decks is given in **2.6.3.10**.

2.6.3.2 The following structural members are not to be considered as effectively contributing to the hull girder sectional area as they do not provide sufficient structural continuity and are therefore to be excluded in the calculation:

- (a) superstructures which do not form a strength deck
- (b) deck houses
- (c) vertically corrugated bulkheads
- (d) bulwarks and gutter plates
- (e) bilge keels
- (f) sniped or non-continuous longitudinal stiffeners if the cross-section under consideration is closer than twice the height of the stiffener from the end of the stiffener.

2.6.3.3 The following definitions of opening are to be applied:

- (a) large openings are openings exceeding $2.5m$ in length and/or $1.2m$ in breadth, where the length is measured along the global x -axis of the ship as defined in **Fig. 4.1.1**
- (b) small openings are openings that are not large openings i.e. manholes, lightening holes, etc.
- (c) isolated openings are openings spaced not less than $1m$ apart in the ship's transverse/vertical direction

2.6.3.4 Large openings and small openings that are not isolated are to be deducted from the sectional area used in the section modulus calculation.

2.6.3.5 Isolated small openings in longitudinal stiffeners or girders are to be deducted if their depth exceeds 25% of the web depth.

2.6.3.6 When several openings are located in or adjacent to the same cross-section, the total equivalent breadth of the combined openings, Σb_{ded} , is to be deducted, see **2.6.3.7 to 2.6.3.8** and **Fig. 4.2.18**.

2.6.3.7 Isolated small openings need not be deducted provided that the sum of their breadths, or shadow area breadths, in one transverse section does not reduce the hull girder section modulus at deck or baseline by more than 3%.

Alternatively isolated small openings need not to be deducted provided the total equivalent breadth of small openings, Σb_{sm} , is less than:

$$\Sigma b_{sm} = 0.06(B_{sect} - \Sigma b_{ded}) \quad (m)$$

Where:

Σb_{sm} : total equivalent breadth of small openings, see **Fig. 4.2.18**

$$= b_{sm1} + b_{sm2} + b_{sm3} \quad (m)$$

B_{sect} : the breadth of the ship at the section being considered, in m

Σb_{ded} : total equivalent breadth of combined openings specified in **2.6.3.7**, in m

The effect of the shadow area of deductible openings is to be taken into account.

2.6.3.8 When calculating the total equivalent breadth of small openings, Σb_{sm} , each opening is assumed to have a longitudinal shadow area, see **Fig. 4.2.18**. This shadow area is obtained by drawing two tangent lines with an angle of 15 *degrees* to the longitudinal axis of the ship.

2.6.3.9 Full or partial compensation of openings may be provided by increasing the sectional area of the plating, longitudinal stiffeners or girders, or other suitable structure. The compensation area is to extend well beyond the forward and aft end of the opening. Any local edge reinforcement of the opening is not to be included in the effective area of the hull girder section modulus calculations. Compensation is not necessary for openings which are not required to be deducted in accordance with **2.6.3.7**.

2.6.3.10 When calculating the ineffective area in way of large openings and in way of non-continuous decks and longitudinal bulkheads, the effective area is to be taken as shown in **Fig. 4.2.19**. The shadow area, which indicates the area that is not effective, is obtained by drawing two tangent lines with an angle of 15 *degrees* to the longitudinal axis of the ship.

Fig. 4.2.18 Calculation of equivalent Breadth

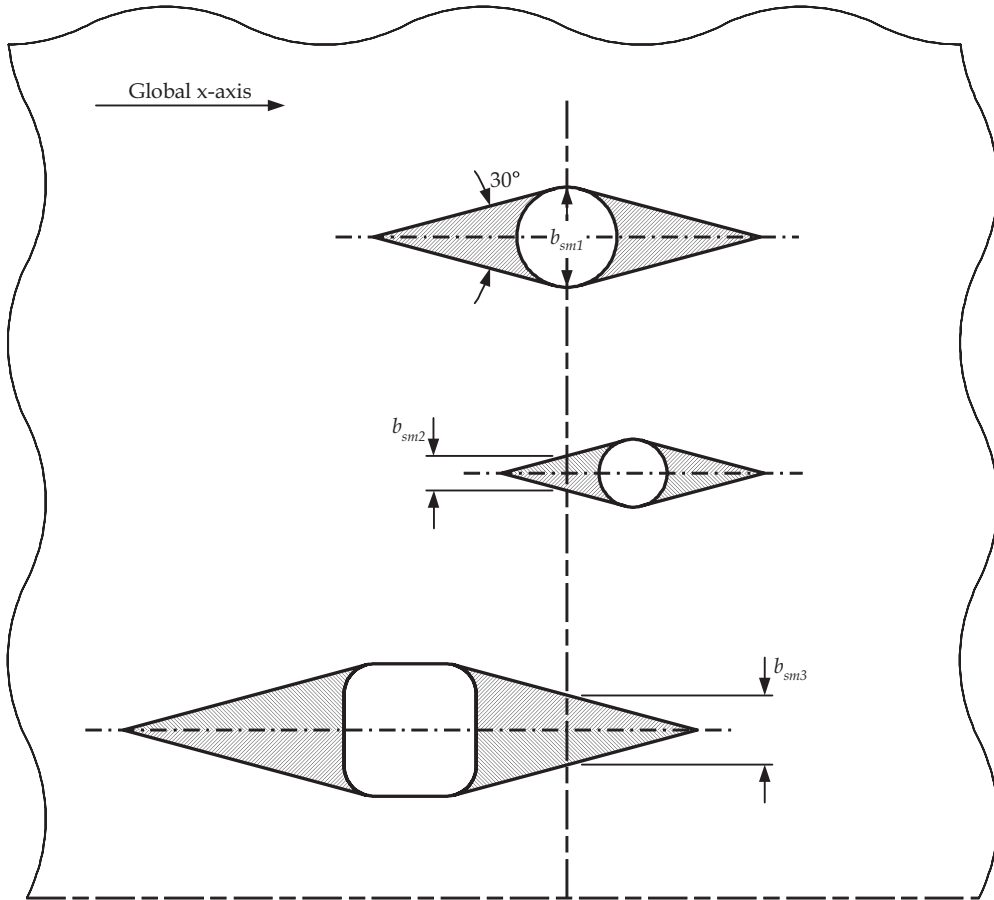
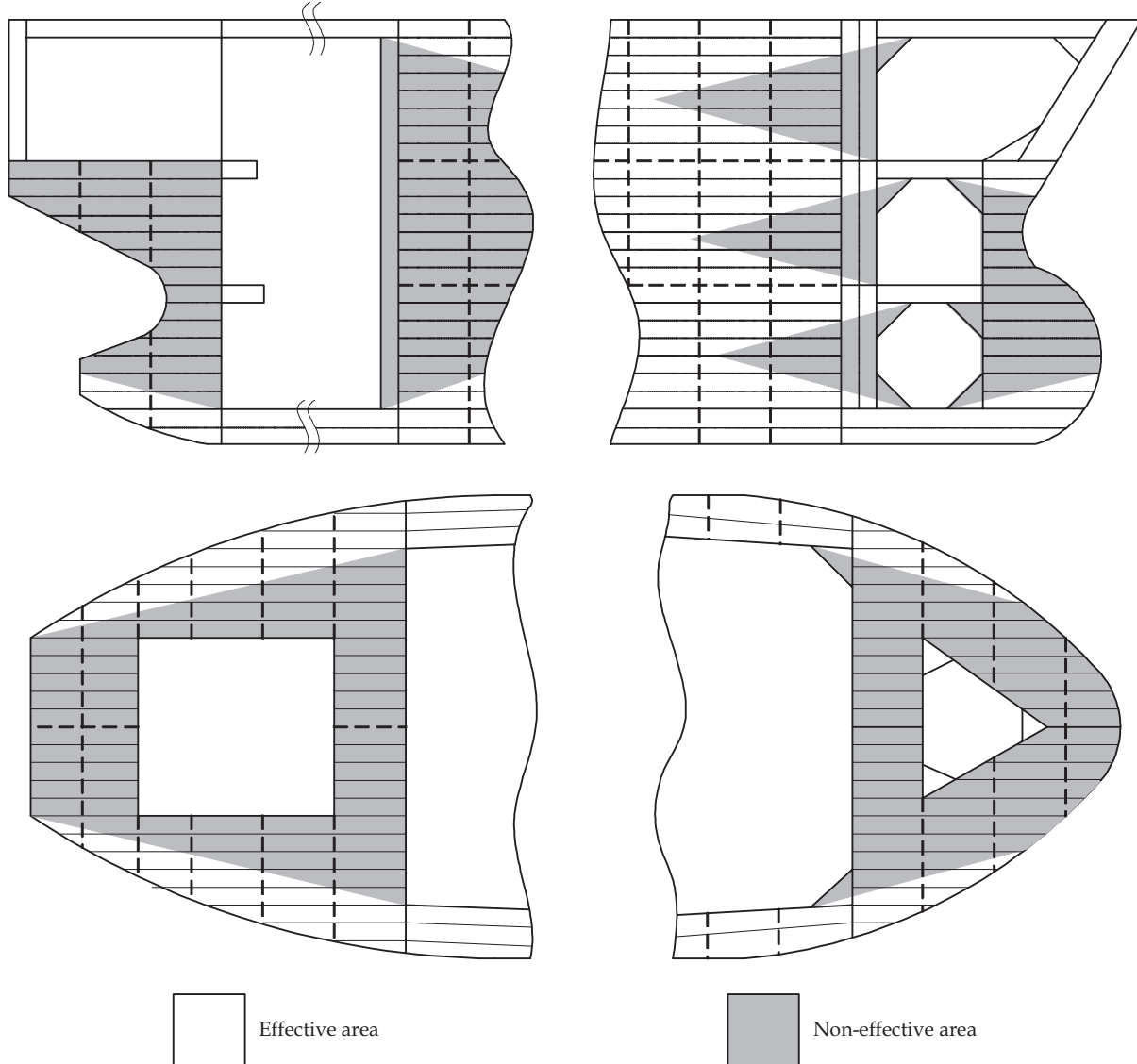

Fig. 4.2.19 Effective Area in way of Non-Continuous Decks and Bulkheads



2.6.4 Effective vertical hull girder shear area

2.6.4.1 The effective net hull girder vertical shear area includes the net plating area of the side shell including the bilge, the inner hull including the hopper side and the outboard girder under and the longitudinal bulkheads including the double bottom girders in line.

2.6.4.2 For calculation of the net hull girder vertical shear area, the net plating area is to be calculated based on the net thickness, t_{net50} , given by the gross thickness minus the corrosion addition $0.5t_{corr}$ of all effective structural members given in 2.6.4.1. Where t_{corr} is as defined in Section 6/3.2.

2.6.4.3 For longitudinal strength members forming the web of the hull girder which are inclined to the vertical, the area of the member to be included in the shear force calculation is to be based on the projected area onto the vertical plane. See Fig. 4.2.20.

2.6.4.4 The calculation of the net effective shear area for vertical and horizontal corrugated bulkheads is to be based on the net effective equivalent thickness, $t_{cg-net50}$, given by:

$$t_{cg-net50} = \left[0.5(t_{w-grs} + t_{f-grs}) \frac{b_{cg}}{b_{w-cg} + b_{f-cg}} \right] - 0.5t_{corr} \quad (mm)$$

Where:

t_{w-grs} : gross corrugation web thickness, in *mm*

t_{f-grs} : gross corrugation flange thickness, in *mm*

b_{cg} : projected length of one corrugation, in *mm*, as defined in Fig. 4.2.20

- b_{w-cg} : breadth of corrugation web, in *mm*, as defined in **Fig. 4.2.20**
- b_{f-cg} : breadth of corrugation flange, in *mm*, as defined in **Fig. 4.2.20**
- t_{corr} : corrosion addition, as defined in **Section 6/3.2**

2.6.4.5 The equivalent net corrugation thickness, $t_{cg-net50}$, is only applicable for the calculation of the effective area, $A_{eff-net50}$, and shear force distribution factor, f_i as defined in **Section 8/1.3.2.2**.

Fig. 4.2.20 Effective Shear Area

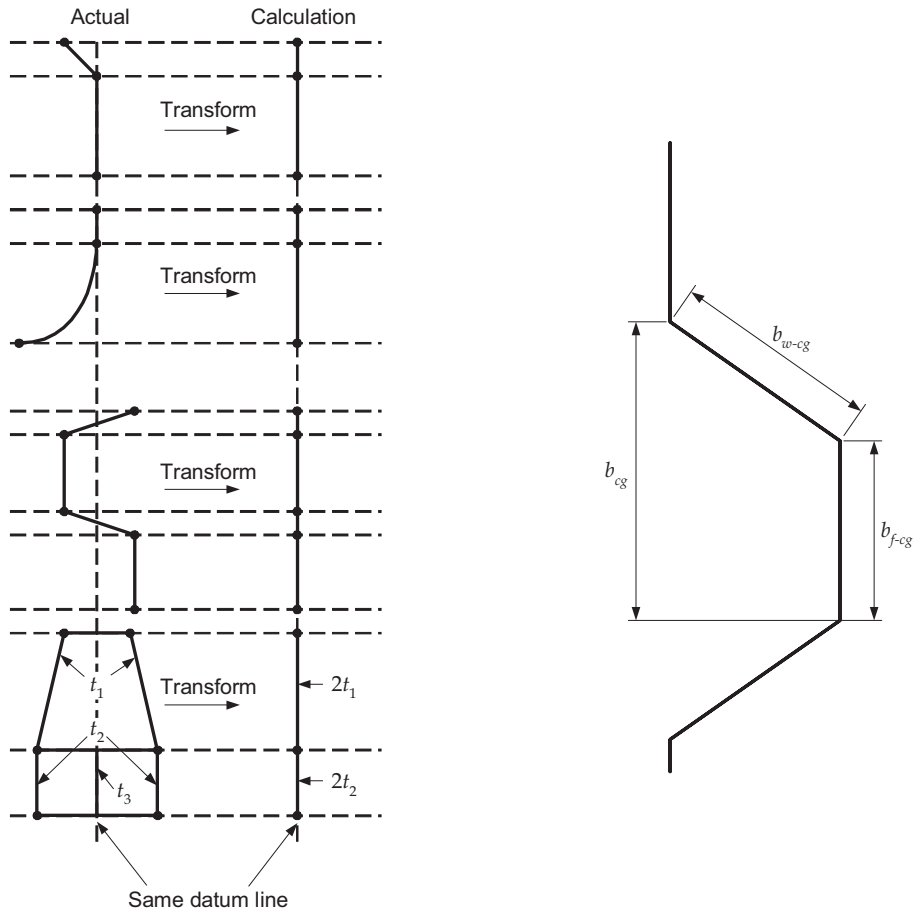

3. Structure Design Details

3.1 Standard Construction Details

3.1.1 Details to be submitted

3.1.1.1 A booklet of standard construction details is to be submitted for review. It is to include the following:

- (a) the proportions of built-up members to demonstrate compliance with established standards for structural stability, see **Section 10**
- (b) the design of structural details which reduce the harmful effects of stress concentrations, notches and material fatigue; such as:
 - details of the ends, at the intersections of members and associated brackets
 - shape and location of air, drainage, and/or lightening holes
 - shape and reinforcement of slots or cut-outs for internals
 - elimination or closing of weld scallops in way of butts, ‘softening’ of bracket toes, reduction of abrupt changes of section or structural discontinuities
 - proportion and thickness of structural members to reduce fatigue response due to engine, propeller or wave induced cyclic stresses, particularly for higher strength steels.

3.2 Termination of Local Support Members

3.2.1 General

3.2.1.1 In general, structural members are to be effectively connected to adjacent structures to avoid hard spots, notches and stress concentrations.

3.2.1.2 Where a structural member is terminated, structural continuity is to be maintained by suitable back-up structure fitted in way of the end connection of frames, or the end connection is to be effectively extended with additional structure and integrated with an adjacent beam, stiffener, etc.

3.2.1.3 All types of stiffeners (longitudinals, beams, frames, bulkhead stiffeners) are to be connected at their ends. However, in special cases sniped ends may be permitted. Requirements for the various types of connections (bracketed, bracketless or sniped ends) are given in **3.2.3** to **3.2.5**.

3.2.2 Longitudinal members

3.2.2.1 All longitudinals are to be kept continuous within the $0.4L_{CSR-T}$ amidships cargo tank region. In special cases, in way of large openings, foundations and partial girders, the longitudinals may be terminated, but end connection and welding is to be specially considered.

3.2.2.2 Where continuity of strength of longitudinal members is provided by brackets, the correct alignment of the brackets on each side of the primary support member is to be ensured, and the scantlings of the brackets are to be such that the combined stiffener/bracket section modulus and effective cross-sectional area are not less than those of the member.

3.2.3 Bracketed connections

3.2.3.1 At bracketed end connections, continuity of strength is to be maintained at the stiffener connection to the bracket and at the connection of the bracket to the supporting member. The brackets are to have scantlings sufficient to compensate for the non-continuous stiffener flange or non-continuous stiffener.

3.2.3.2 The arrangement of the connection between the stiffener and the bracket is to be such that at no point in the connection, the section modulus is less than that required for the stiffener.

3.2.3.3 Minimum net bracket thickness, $t_{bkt-net}$, is to be taken as:

$$t_{bkt-net} = \left(2 + f_{bkt} \sqrt{Z_{rl-net}} \right) \left(\sqrt{\frac{\sigma_{ydl-stf}}{\sigma_{ydl-bkt}}} \right) \quad (mm)$$

, but is not to be less than $6mm$ and need not be greater than $13.5mm$

Where:

f_{bkt} 0.2 for brackets with flange or edge stiffener

0.3 for brackets without flange or edge stiffener

Z_{rl-net} : net rule section modulus, for the stiffener, in cm^3 . In the case of two stiffeners connected, it need not be taken as greater than that of the smallest connected stiffener

σ_{yd-stf} : specified minimum yield stress of the material of the stiffener, in N/mm^2

Σ_{yd-bkt} : specified minimum yield stress of the material of the bracket, in N/mm^2

3.2.3.4 Brackets to provide fixity of end rotation are to be fitted at the ends of discontinuous local support members, except as otherwise permitted by **3.2.4**. The end brackets are to have arm lengths, l_{bkt} , not less than:

$$l_{bkt} = c_{bkt} \sqrt{\frac{Z_{rl-net}}{t_{bkt-net}}} \quad mm, \text{ but is not to be less than:}$$

1.8 times the depth of the stiffener web for connections where the end of the stiffener web is supported and the bracket is welded in line with the stiffener web or with offset necessary to enable welding, see **Fig. 4.3.1(c)**

4.3.1(c)

2.0 times for other cases, see **Fig. 4.3.1(a), (b) and (d)**

Where:

c_{bkt} 65 for brackets with flange or edge stiffener

70 for brackets without flange or edge stiffener

Z_{rl-net} : net rule section modulus, for the stiffener, in cm^3 . In the case of two stiffeners connected, it need not be taken as greater than that of the smallest connected stiffener

$t_{bkt-net}$: minimum net bracket thickness, as defined in **3.2.3.3**

3.2.3.4bis In case of different arm lengths the lengths of the arms, measured from the plating to the toe of the bracket, are to be such that the sum of them is greater than $2l_{bkt}$ and each arm not to be less than $0.8l_{bkt}$, where l_{bkt} is as defined in **3.2.3.4**.

Fig. 4.3.1 Bracket Arm Length

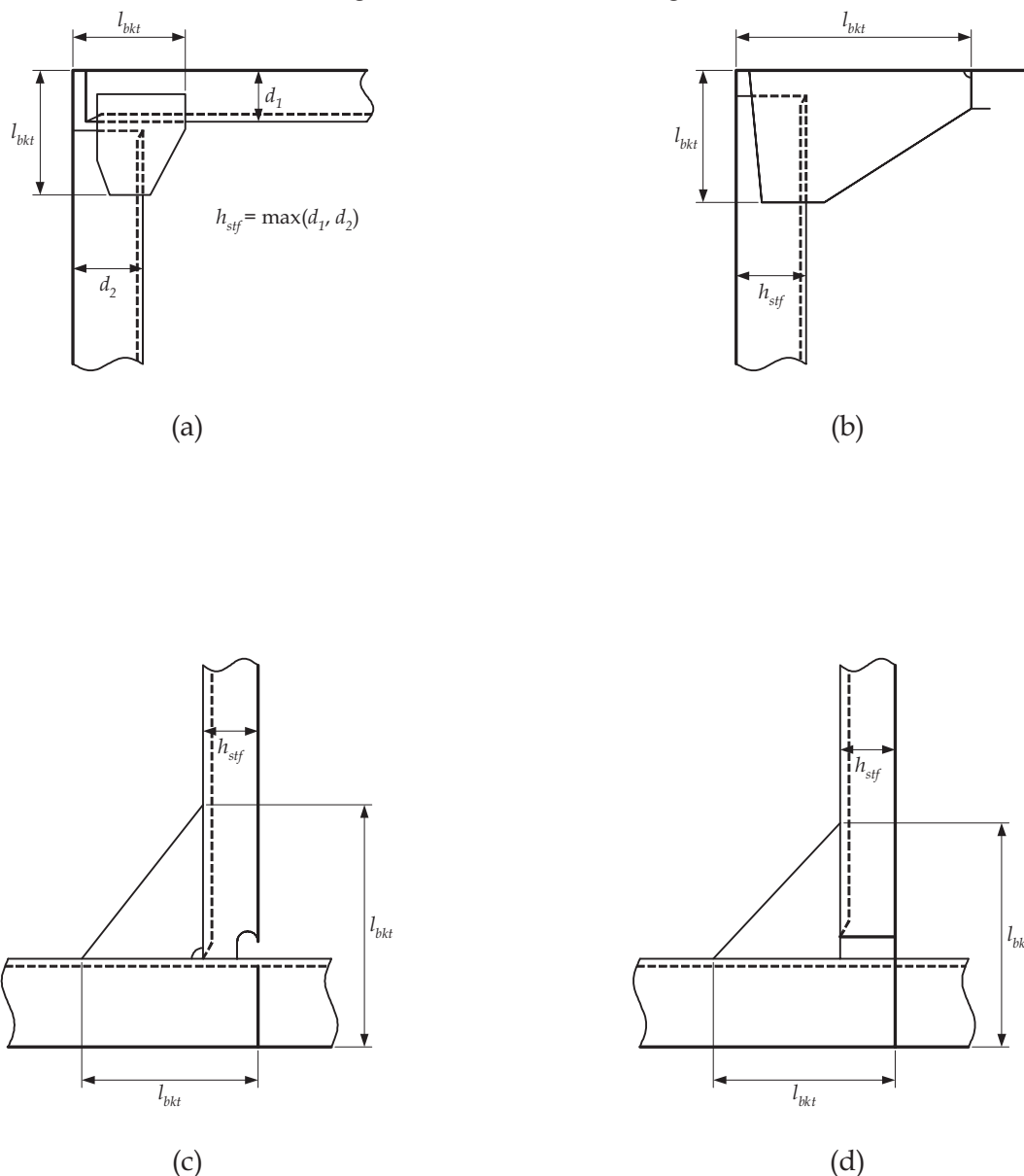
Note

1. For stiffeners of configuration **(b)** that are not lapped, the bracket arm length l_{bkt} is not to be less than the stiffener height h_{stf} .
2. For stiffener arrangements similar to **(c)** and **(d)** where the smaller attached stiffener, labelled as h_{stf} , is connected to a primary support member or bulkhead, the height of the bracket is not to be less than the height of the attached stiffener, h_{stf} .

3.2.3.5 The proportions and edge stiffening of brackets are to be in accordance with the requirements of Section 10/2.4.

Where an edge stiffener is required, the depth of stiffener web, d_w , is not to be less than:

$$d_w = 45 \left(1 + \frac{Z_{rl-net}}{2000} \right) \quad \text{mm, but is not to be less than } 50\text{mm}$$

Where:

Z_{rl-net} : net rule section modulus, for the stiffener, in cm^3 . In the case of two stiffeners connected, it need not be taken as greater than that of the smallest connected stiffener

3.2.4 Bracketless connections

3.2.4.1 Local support members, for example longitudinals, beams, frames and bulkhead stiffeners forming part of the hull structure, are generally to be connected at their ends, in accordance with the requirements of 3.2.2 and 3.2.3.

3.2.4.2 Where alternative connections are adopted, the proposed arrangements will be specially considered.

3.2.4.3 The design of end connections and their supporting structure is to be such as to provide adequate resistance to rotation and displacement of the joint.

3.2.5 Sniped ends

3.2.5.1 Stiffeners with sniped ends may be used where dynamic loads are small and where the incidence of vibration is considered to be small, i.e. structure not in the stern area and structure not in the vicinity of engines or generators, provided the net thickness of plating supported by the stiffener, t_{p-net} , is not less than:

$$t_{p-net} = c_1 \sqrt{\left(1000l - \frac{s}{2}\right) \frac{sPk}{10^6}} \quad (mm)$$

Where:

l : stiffener span, in m

s : stiffener spacing, in mm , as defined in 2.2

P : design pressure for the stiffener for the design load set being considered, in kN/m^2 . The design load sets and method to derive the design pressure are to be taken in accordance with the following criteria, which define the acceptance criteria set to be used

- (a) **Table 8.2.5** in the cargo tank region
- (b) **Section 8/3.9.2.2** in the area forward of the forward cargo tank, and in the aft end
- (c) **Section 8/4.8.1.2** in the machinery space
- (d) **Section 8/6.2.4.1** and **6.2.5.3** as applicable for the particular structure under consideration

k : higher strength steel factor, as defined in **Section 6/1.1.4**

c_1 : coefficient for the design load set being considered, to be taken as

=1.2	for acceptance criteria set AC1 and sloshing design load
=1.1	for acceptance criteria set AC2

3.2.5.2 Bracket toes and sniped end members are, in general, to be kept within $25mm$ of the adjacent member. The maximum distance is not to exceed $40mm$ unless the bracket or member is supported by another member on the opposite side of the plating. Special attention is to be given to the end taper by using a sniped end of not more than 30 degrees. The depth of toe or sniped end is, generally, not to exceed the thickness of the bracket toe or sniped end member, but need not be less than $15mm$.

3.2.5.3 The end attachments of non-load bearing members may be snipe ended. The sniped end is to be not more than 30 degrees and is generally to be kept within $50mm$ of the adjacent member unless it is supported by a member on the opposite side of the plating. The depth of the toe is generally not to exceed $15mm$.

3.2.6 Air and drain holes and scallops

3.2.6.1 Air and drain holes and scallops are to be kept at least $200mm$ clear of the toes of end brackets, end connections and other areas of high stress concentration measured along the length of the stiffener toward the mid-span and $50mm$ measured along the length in the opposite direction. See **Fig. 4.3.2(b)**. Openings that have been fitted with closing plates, such as scallops, may be permitted in way of block fabrication butts. In areas where the shear stress is less than 60 percent of the allowable limit, alternative arrangements may be accepted. Openings are to be well-rounded. **Fig. 4.3.2(a)** shows some examples of air and drain holes and scallops. In general, the ratio of a/b , as defined in **Fig. 4.3.2(a)**, is to be between 0.5 and 1.0 . In fatigue sensitive areas further consideration may be required with respect to the details and arrangements of openings and scallops.

Fig. 4.3.2(a) Examples of Air and Drain Holes and Scallops

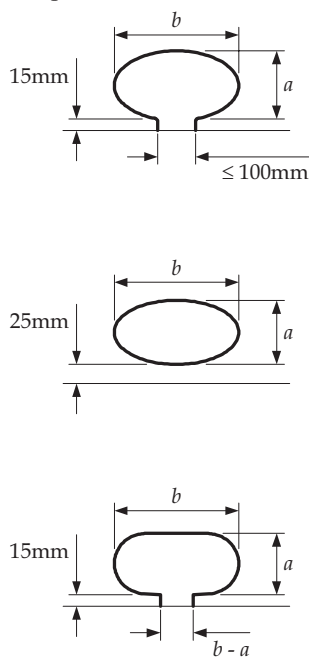

Note

The details shown in this figure are for guidance and illustration only.

Fig. 4.3.2(b) Location of Air and Drain Holes

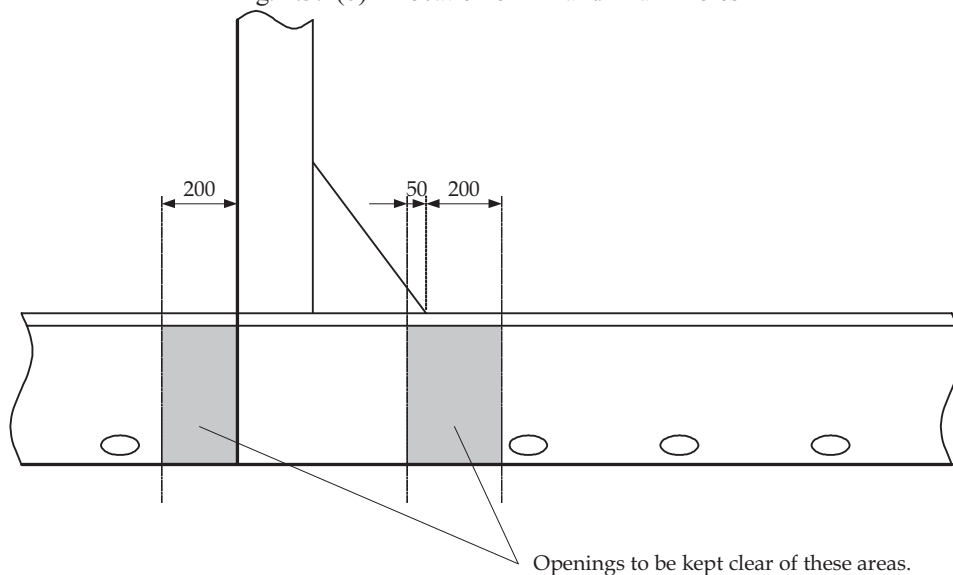

3.2.7 Special requirements

3.2.7.1 Closely spaced scallops or drain holes, i.e. where the distance between scallops/drain holes is less than twice the width b as shown in **Fig. 4.3.2(a)**, are not permitted in longitudinal strength members or within 20% of the stiffener span measured from the end of the stiffener. Widely spaced air or drain holes may be permitted provided that they are of elliptical shape or equivalent to minimise stress concentration and are, in general, cut clear of the weld connection.

3.3 Termination of Primary Support Members

3.3.1 General

3.3.1.1 Primary support members are to be arranged to ensure effective continuity of strength. Abrupt changes of depth or section are to be avoided. Primary support members in tanks are to form a continuous line of support and, wherever possible, a complete ring system.

3.3.1.2 The members are to have adequate lateral stability and web stiffening, and the structure is to be arranged to minimise hard spots and other sources of stress concentration. Openings are to have well-rounded corners and are to be located considering the stress distribution and buckling strength of the panel.

3.3.2 End connection

3.3.2.1 Primary support members are to be provided with adequate end fixity by brackets or equivalent structure. The design of end connections and their supporting structure is to provide adequate resistance to rotation and displacement of the joint and effective distribution of the load from the member.

3.3.2.2 The ends of brackets are generally to be soft-toed. The free edges of the brackets are to be stiffened. Scantlings and details are given in **3.3.3**.

3.3.2.3 Where primary support members are subject to concentrated loads additional strengthening may be required, particularly if these are out of line with the member web.

3.3.2.4 In general, ends of primary support members or connections between primary support members forming ring systems are to be provided with brackets. Bracketless connections may be applied provided that there is adequate support of the adjoining face plates.

3.3.3 Brackets

3.3.3.1 In general, the arm lengths of brackets connecting primary support members are not to be less than the web depth of the member, and need not be taken as greater than 1.5 times the web depth. The thickness of the bracket is, in general, not to be less than that of the girder web plate.

3.3.3.2 For a ring system where the end bracket is integral with the webs of the members and the face plate is carried continuously along the edges of the members and the bracket, the full area of the largest face plate is to be maintained close to the mid point of the bracket and gradually tapered to the smaller face plates. Butts in face plates are to be kept well clear of the bracket toes.

3.3.3.3 Where a wide face plate abuts a narrower one, the taper is generally not to be greater than 1 in 4. Where a thick face plate abuts against a thinner one and the difference in thickness is greater than 4mm, the taper of the thickness is not to be greater than 1 in 3.

3.3.3.4 Face plates of brackets (typical brackets similar to those indicated in **Fig. 4.2.7b**) are to have a net cross-sectional area, A_{f-net} , which is not to be less than:

$$A_{f-net} = l_{bkt-edge} t_{bkt-net} \quad (cm^2)$$

Where:

$l_{bkt-edge}$: length of free edge of bracket, in *m*. For brackets that are curved the length of the free edge may be taken as the length of the tangent at the midpoint of the free edge. If $l_{bkt-edge}$ is greater than 1.5*m*, 40 percent of the face plate area is to be in a stiffener fitted parallel to the free edge and a maximum 0.15*m* from the edge

$t_{bkt-net}$: minimum net bracket thickness, in *mm*, as defined in **3.2.3.3**

3.3.4 Bracket toes

3.3.4.1 The toes of brackets are not to land on unstiffened plating. Notch effects at the toes of brackets may be reduced by making the toe concave or otherwise tapering it off. In general, the toe height is not to be greater than the thickness of the bracket toe, but need not be less than 15mm. The end brackets of large primary support members are to be soft-toed. Where any end bracket has a face plate, it is to be sniped and tapered at an angle not greater than 30°.

3.3.4.2 Where primary support members are constructed of higher strength steel, particular attention is to be paid to the design of the end bracket toes in order to minimise stress concentrations. Sniped face plates, which are welded onto the edge of primary support member brackets, are to be carried well around the radiused bracket toe and are to incorporate a taper not greater than 1 in 3. Where sniped face plates are welded adjacent to the edge of primary support member brackets, adequate cross-sectional area is to be provided through the bracket toe at the end of the snipe. In general, this area, measured perpendicular to the face plate is to be not less than 60 percent of the full cross-sectional area of the face plate, see **Fig. 4.3.3**.

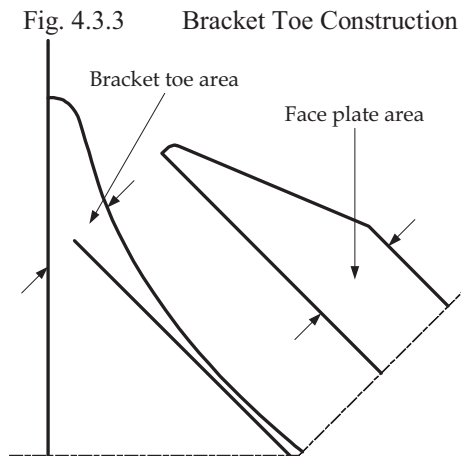

Note :

The details shown in this figure are only used to illustrate items described in the text and are not intended to represent design guidance or recommendations.

3.4 Intersections of Continuous Local Support Members and Primary Support Members

3.4.1 General

3.4.1.1 Cut-outs for the passage of stiffeners through the web of primary support members, and the related collaring arrangements, are to be designed to minimize stress concentrations around the perimeter of the opening and on the attached web stiffeners.

3.4.1.2 Cut-outs in way of cross-tie ends and floors under bulkhead stools or in high stress areas are to be fitted with “full” collar plates, see **Fig. 4.3.4**.

3.4.1.3 Lug type collar plates are to be fitted in cut-outs where required for compliance with the requirements of **3.4.3**, and in areas of significant stress concentrations, e.g., in way of primary support member toes. See **Fig. 4.3.5** for typical lug arrangements.

3.4.1.4 When, in the following locations, the calculated direct stress, σ_w , in the primary support member web stiffener according to **3.4.3.5** exceeds 80% of the permissible values a soft heel is to be provided in way of the heel of primary support member web stiffeners:

- (a) connection to shell envelope longitudinals below the scantling draught, T_{sc}
- (b) connection to inner bottom longitudinals.

A soft heel is not required at the intersection with watertight bulkheads and primary support members, where a back bracket is fitted or where the primary support member web is welded to the stiffener face plate. The soft heel is to have a keyhole, similar to that shown in **Fig. 4.3.6(c)**.

Fig. 4.3.4 Collars for Cut-outs in Areas of High Stress

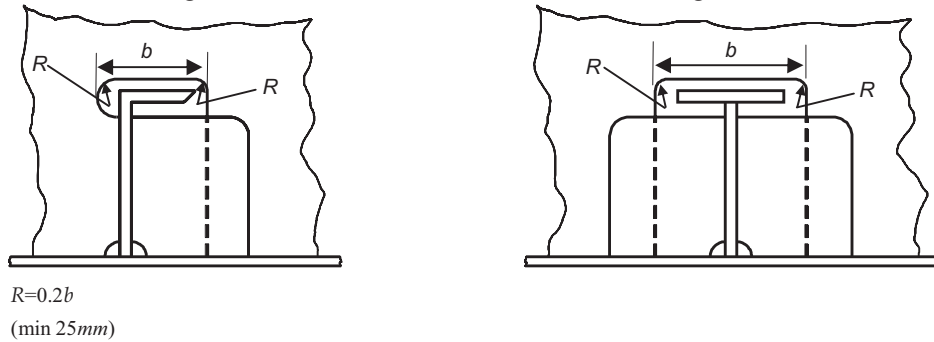

3.4.2 Details of cut-outs

3.4.2.1 In general, cut-outs are to have rounded corners and the corner radii, R , are to be as large as practicable, with a minimum of 20 percent of the breadth, b , of the cut-out or 25mm, whichever is greater, but need not be greater than 50 mm, see Fig. 4.3.4. Consideration will be given to other shapes on the basis of maintaining equivalent strength and minimizing stress concentration.

3.4.3 Connection between primary support members and intersecting stiffeners (local support members)

3.4.3.1 The cross-sectional areas of the connections are to be determined from the proportion of load transmitted through each component in association with its appropriate permissible stress.

3.4.3.2 The total load, W , transmitted through the connection to the primary support member is given by:

$$W = P s \left(S - \frac{s}{2000} \right) 10^{-3} \quad (kN)$$

Where:

P : design pressure for the stiffener for the design load set being considered, in kN/m^2 .

The design load sets, method to derive the design pressure and applicable acceptance criteria set are to be taken in accordance with the following criteria, which define the Acceptance Criteria Set to be used

Table 8.2.5 in the cargo tank region

Section 8/3.9.2.2 in the area forward of the forward cargo tank

Section 8/3.9.2.2 in the aft end

Section 8/4.8.1.2 in the machinery space

Section 8/6.2.4.1 if subjected to sloshing loads

Section 8/6.3.5.1 if subjected to bottom slamming loads

Section 8/6.4.5.1 if subjected to bow impact loads

S : primary support member spacing, in m , as defined in **Section 4/2.2**

s : stiffener spacing, in mm , as defined in **Section 4/2.2**

For stiffeners having different primary support member spacing, S , and/or different pressure, P , at each side of the primary support member, the average load for the two sides is to be applied, e.g. vertical stiffeners at transverse bulkhead.

3.4.3.3 The load, W_1 , transmitted through the shear connection is to be taken as follows.

If the web stiffener is connected to the intersecting stiffener:

$$W_1 = W \left(\alpha_a + \frac{A_{1-net}}{4 f_c A_{w-net} + A_{1-net}} \right) \quad (kN)$$

If the web stiffener is not connected to the intersecting stiffener:

$$W_1 = W$$

Where:

W : the total load, in kN , as defined in **3.4.3.2**

α_a : panel aspect ratio, not to be taken greater than 0.25

$$= \frac{s}{1000 S}$$

- S : primary support member spacing, in m
 s : stiffener spacing, in mm
 A_{1-net} : effective net shear area of the connection, to be taken as the sum of the components of the connection
 $A_{1d-net} + A_{1c-net}$ (cm^2)
 in case of a slit type slot connections area, A_{1-net} , is given by:
 $A_{1-net} = 2l_d t_{w-net} 10^{-2}$ (cm^2)
 in case of a typical double lug or collar plate connection area, A_{1-net} , is given by:
 $A_{1-net} = 2f_1 l_c t_{c-net} 10^{-2}$ (cm^2)
 A_{1d-net} : net shear connection area excluding lug or collar plate, as given by the following and **Fig. 4.3.5**
 $A_{1d-net} = l_d t_{w-net} 10^{-2}$ (cm^2)
 l_d : length of direct connection between stiffener and primary support member web, in mm
 t_{w-net} : net web thickness of the primary support member, in mm
 A_{1c-net} : net shear connection area with lug or collar plate, given by the following and **Fig. 4.3.5**
 $A_{1c-net} = f_1 l_c t_{c-net} 10^{-2}$ (cm^2)
 l_c : length of connection between lug or collar plate and primary support member, in mm
 t_{c-net} : net thickness of lug or collar plate, not to be taken greater than the net thickness of the adjacent primary support member web, in mm
 f_1 : shear stiffness coefficient
 $= 1.0$ for stiffeners of symmetrical cross section
 $= 140/w$ for stiffeners of asymmetrical cross section but is not to be taken as greater than 1.0
 w : the width of the cut-out for an asymmetrical stiffener, measured from the cut-out side of the stiffener web, in mm , as indicated in **Fig. 4.3.5**
 A_{w-net} : effective net cross-sectional area of the primary support member web stiffener in way of the connection including backing bracket where fitted, as shown in **Fig. 4.3.6**, in cm^2 . If the primary support member web stiffener incorporates a soft heel ending or soft heel and soft toe ending, A_{w-net} , is to be measured at the throat of the connection, as shown in **Fig. 4.3.6**.
 f_c : the collar load factor defined as follows
 for intersecting stiffeners of symmetrical cross section
 $= 1.85$ for $A_{w-net} \leq 14$
 $= 1.85 - 0.0441(A_{w-net} - 14)$ for $14 < A_{w-net} \leq 31$
 $= 1.1 - 0.013(A_{w-net} - 31)$ for $31 < A_{w-net} \leq 58$
 $= 0.75$ for $A_{w-net} > 58$
 for intersecting stiffeners of asymmetrical cross section
 $= 0.68 + 0.0172 \frac{l_s}{A_{w-net}}$
 where:
 $l_s = l_c$ for a single lug or collar plate connection to the primary support member
 $= l_d$ for a single sided direct connection to the primary support member
 $=$ mean of the connection length on both sides, i.e., in the case of a lug or collar plus a direct connection, $l_s = 0.5(l_c + l_d)$

3.4.3.4 The load, W_2 , transmitted through the primary support member web stiffener is to be taken as follows.

If the web stiffener is connected to the intersecting stiffener:

$$W_2 = W \left(1 - \alpha_a - \frac{A_{1-net}}{4f_c A_{w-net} + A_{1-net}} \right) \quad (kN)$$

If the web stiffener is not connected to the intersecting stiffener:

$$W_2 = 0$$

Where:

- W : the total load, in kN , as defined in **3.4.3.2**
- α_a : panel aspect ratio

$$= \frac{s}{1000S}$$
- S : primary support member spacing, in m
- s : stiffener spacing, in mm
- A_{1-net} : effective net shear area of the connection, in cm^2 , as defined in **3.4.3.3**
- f_c : collar load factor, as defined in **3.4.3.3**
- A_{w-net} : effective net cross-sectional area of the primary support member web stiffener, in cm^2 , as defined in **3.4.3.3**

3.4.3.5 The values of A_{w-net} , A_{wc-net} and A_{1-net} are to be such that the calculated stresses satisfy the following criteria: for the connection to the primary support member web stiffener away from the weld:

$$\sigma_w \leq \sigma_{perm}$$

for the connection to the primary support member web stiffener in way of the weld:

$$\sigma_{wc} \leq \sigma_{perm}$$

for the shear connection to the primary support member web:

$$\tau_w \leq \tau_{perm}$$

Where:

σ_w : direct stress in the primary support member web stiffener at the minimum bracket area away from the weld connection

$$= \frac{10W_2}{A_{w-net}} \quad (N/mm^2)$$

σ_{wc} : direct stress in the primary support member web stiffener in way of the weld connection

$$= \frac{10W_2}{A_{wc-net}} \quad (N/mm^2)$$

τ_w : shear stress in the shear connection to the primary support member

$$= \frac{10W_1}{A_{1-net}} \quad (N/mm^2)$$

A_{w-net} : effective net cross-sectional area of the primary support member web stiffener, in cm^2 , as defined in **3.4.3.3**

A_{wc-net} : effective net area of the web stiffener in way of the weld as shown in **Fig. 4.3.6**, in cm^2

A_{1-net} : effective net shear area of the connection, in cm^2 , as defined in **3.4.3.3**

W_1 : load transmitted through the shear connection, in kN , as defined in **3.4.3.3**

W_2 : load transmitted through the web stiffener, in kN , as defined in **3.4.3.4**

σ_{perm} : permissible direct stress given in **Table 4.3.1** for the applicable acceptance criteria, see **3.4.3.2**, in N/mm^2

τ_{perm} : permissible shear stress given in **Table 4.3.1** for the applicable acceptance criteria, see **3.4.3.2**, in N/mm^2

3.4.3.5 bis1 When total load, W , is bottom slamming or bow impact loads the following criteria apply in lieu of **3.4.3.3** to **3.4.3.5**:

$$0.9W \leq \frac{(A_{1-net} \tau_{perm} + A_{w-net} \sigma_{perm})}{10} \quad (kN)$$

A_{1-net} : effective net shear area in cm^2 of the connection, as defined in **3.4.3.3**.

A_{w-net} : effective net cross-sectional area in cm^2 of the primary support member web stiffener in way of the connection including backing bracket where fitted, as defined in **3.4.3.3**.

σ_{perm} : permissible direct stress given in **Table 4.3.1** for AC-3, in N/mm^2

τ_{perm} : permissible shear stress given in **Table 4.3.1** for AC-3, in N/mm^2

Table 4.3.1 Permissible Stresses for Connection between Stiffeners and Primary Support Members

Item	Direct Stress, σ_{perm} , in N/mm^2			Shear Stress, τ_{perm} , in N/mm^2		
	Acceptance Criteria Set See 3.4.3.2			Acceptance Criteria Set See 3.4.3.2		
	AC1	AC2	AC3	AC1	AC2	AC3
Primary support member web stiffener	$0.83 \sigma_{yd}^{(3)}$	σ_{yd}	σ_{yd}	-	-	-
Primary support member web stiffener to intersecting stiffener in way of weld connection:						
double continuous fillet	$0.58 \sigma_{yd}^{(3)}$	$0.70 \sigma_{yd}^{(3)}$	σ_{yd}	-	-	-
partial penetration weld	$0.83 \sigma_{yd}^{(2)(3)}$	$\sigma_{yd}^{(2)}$	σ_{yd}	-	-	-
Primary support member stiffener to intersecting stiffener in way of lapped welding	$0.50 \sigma_{yd}$	$0.60 \sigma_{yd}$	σ_{yd}	-	-	-
Shear connection including lugs or collar plates:						
single sided connection	-	-	-	$0.71 \tau_{yd}$	$0.85 \tau_{yd}$	τ_{yd}
double sided connection	-	-	-	$0.83 \tau_{yd}$	τ_{yd}	τ_{yd}

Where:

- τ_{perm} permissible shear stress, in N/mm^2
 σ_{perm} permissible direct stress, in N/mm^2
 σ_{yd} minimum specified material yield stress, in N/mm^2
 $\tau_{yd} = \frac{\sigma_{yd}}{\sqrt{3}}$, in N/mm^2

Note

1. The stress computation on plate type members is to be performed on the basis of net thicknesses, whereas gross values are to be used in weld strength assessments, see 3.4.3.11.
2. The root face is not to be greater than one third of the gross thickness of the primary support member stiffener.
3. Allowable stresses may be increased by 5 percent where a soft heel is provided in way of the heel of the primary support member web stiffener.

3.4.3.6 Where a backing bracket is fitted in addition to the primary support member web stiffener, it is to be arranged on the opposite side to, and in alignment with the web stiffener. The arm length of the bracket is to be not less than the depth of the web stiffener and its net cross-sectional area through the throat of the bracket is to be included in the calculation of A_{w-net} as shown in Fig. 4.3.6.

3.4.3.7 Lapped connections of primary support member web stiffeners or tripping brackets to local support members are not permitted in the cargo tank region, e.g., lapped connections between transverse and longitudinal local support members.

3.4.3.8 Fabricated stiffeners having their face plate welded to the side of the web, leaving the edge of the web exposed, are not recommended for side shell and longitudinal bulkhead longitudinals. Where such sections are connected to the primary support member web stiffener, a symmetrical arrangement of connection to the transverse members is to be incorporated. This may be implemented by fitting backing brackets on the opposite side of the transverse web or bulkhead. In way of the cargo tank region, the primary support member web stiffener and backing brackets are to be butt welded to the intersecting stiffener web.

3.4.3.9 Where the web stiffener of the primary support member is parallel to the web of the intersecting stiffener, but not connected to it, the offset primary support member web stiffener may be located as shown in Fig. 4.3.7. The offset primary support member web stiffener is to be located in close proximity to the slot edge. See also Fig. 4.3.7. The ends of the offset web stiffeners are to be suitably tapered and softened.

3.4.3.10 Alternative arrangements will be specially considered on the basis of their ability to transmit load with equivalent effectiveness. Details of calculations made and/or testing procedures and results are to be submitted.

3.4.3.11 The size of the fillet welds is to be calculated according to **Section 6/5** based on the weld factors given in **Table 4.3.2**. For the welding in way of the shear connection the size is not to be less than that required for the primary support member web plate for the location under consideration.

Table 4.3.2 Weld Factors for Connection between Stiffeners and Primary Support Members

Item	Weld factor
Primary support member stiffener to intersecting stiffener	$0.6 \sigma_{wc} / \sigma_{perm}$ not to be less than 0.38
Shear connection inclusive lug or collar plate	0.38
Shear connection inclusive lug or collar plate, where the web stiffener of the primary support member is not connected to the intersection stiffener	$0.6 \tau_w / \tau_{perm}$ not to be less than 0.44

Where:

τ_w shear stress, as defined in **3.4.3.5**

σ_w as defined in **3.4.3.5**

τ_{perm} permissible shear stress, in N/mm^2 , see **Table 4.3.1**

σ_{perm} permissible direct stress, in N/mm^2 see **Table 4.3.1**

Fig. 4.3.5 Symmetric and Asymmetric Cut outs

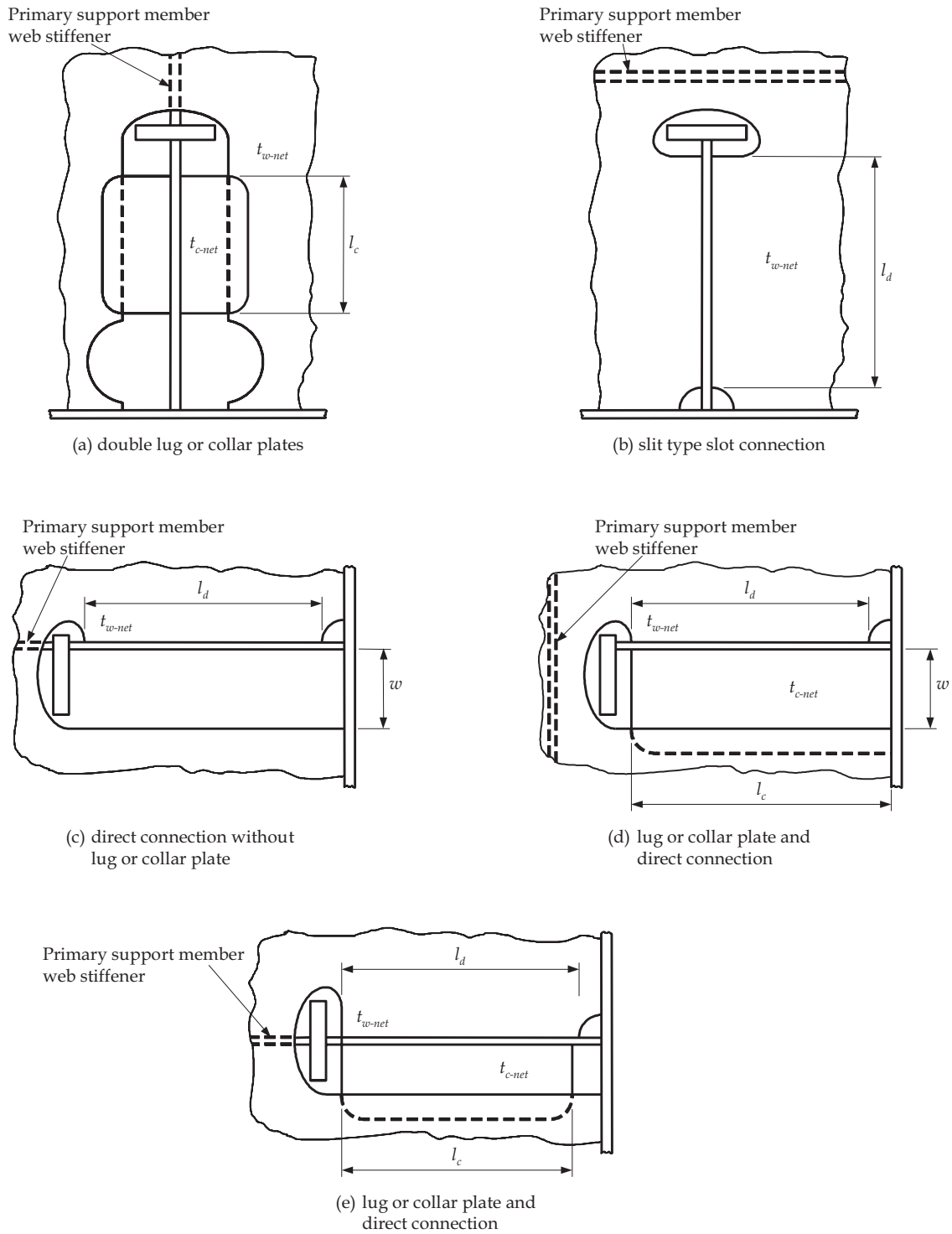

Note

The details shown in this figure are only used to illustrate symbols and definitions and are not intended to represent design guidance or recommendations.

Fig. 4.3.6 Primary Support Member Web Stiffener Details

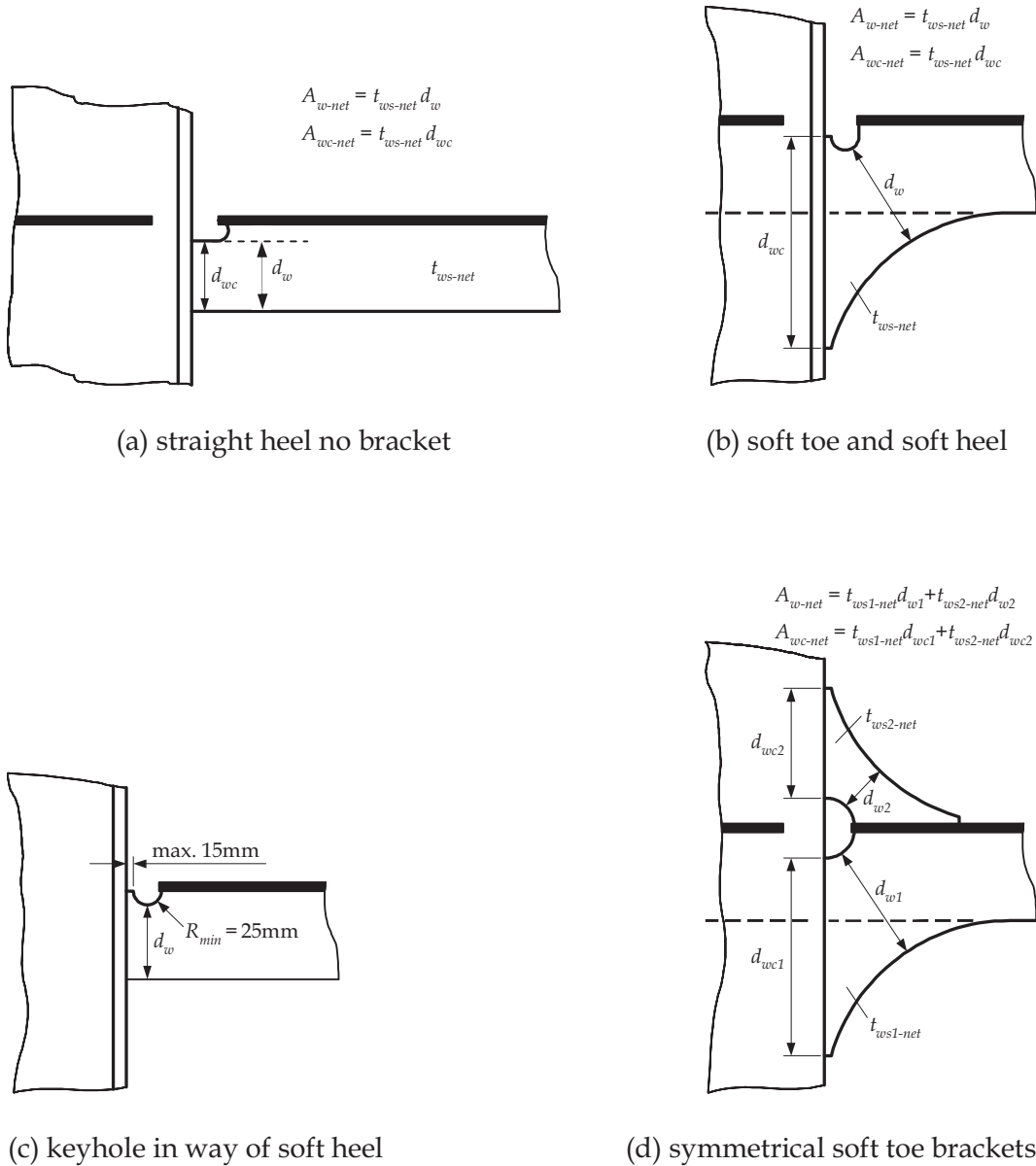

Where:

- t_{ws-net} , $t_{ws1-net}$ and $t_{ws2-net}$: net thickness of the primary support member web stiffener/backing bracket, in *mm*
- d_w , d_{w1} and d_{w2} : minimum depth of the primary support member web stiffener/backing bracket, in *mm*
- d_{wc} , d_{wc1} and d_{wc2} : length of connection between the primary support member web stiffener/backing bracket and the local support stiffener, in *mm*

Note :

Except where specific dimensions are noted for the details of the keyhole in way of the soft heel, see 3.4.1.4, the details shown in this figure are only used to illustrate symbols and definitions and are not intended to represent design guidance or recommendations.

Fig. 4.3.7 Offset Primary Support Member Web Stiffeners

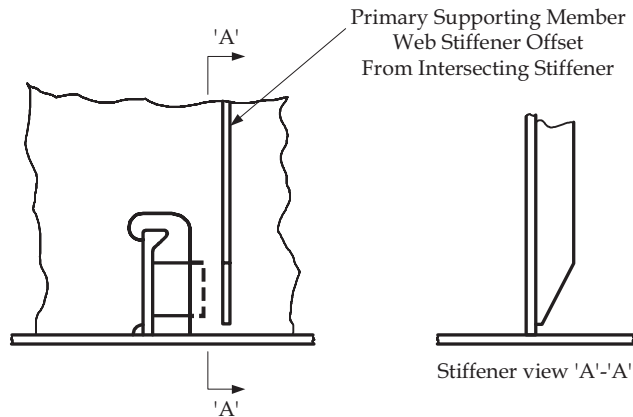

3.5 Openings

3.5.1 General

3.5.1.1 Openings are to have well rounded corners.

3.5.1.2 Manholes, lightening holes and other similar openings are to be avoided in way of concentrated loads and areas of high shear. In particular, manholes and similar openings are to be avoided in high stress areas unless the stresses in the plating and the panel buckling characteristics have been calculated and found satisfactory. Examples of high stress areas include:

- in vertical or horizontal diaphragm plates in narrow cofferdams/double plate bulkheads within one-sixth of their length from either end
- in floors or double bottom girders close to their span ends
- above the heads and below the heels of pillars.

Where larger openings than given by 3.5.2 or 3.5.3 are proposed, the arrangements and compensation required will be specially considered.

3.5.2 Manholes and lightening holes in single skin sections not requiring reinforcement

3.5.2.1 Openings cut in the web with depth of opening not exceeding 25 percent of the web depth and located so that the edges are not less than 40 percent of the web depth from the faceplate do not generally require reinforcement. The length of opening is not to be greater than the web depth or 60 percent of the local support member spacing, whichever is greater. The ends of the openings are to be equidistant from the corners of cut outs for local support members.

3.5.3 Manholes and lightening holes in double skin sections not requiring reinforcement

3.5.3.1 Where openings are cut in the web and are clear of high stress areas, reinforcement of these openings is not required provided that the depth of the opening does not exceed 50 percent of the web depth and is located so that the edges are well clear of cut outs for the passage of local support members.

3.5.4 Manholes and lightening holes requiring reinforcement

3.5.4.1 Manholes and lightening holes are to be stiffened as required by 3.5.4.2 and 3.5.4.3. The stiffening requirements of 3.5.4.2 and 3.5.4.3 may be modified where alternative arrangements are demonstrated as satisfactory with regards to stress and stability, in accordance with analysis methods described in Section 9/2.

3.5.4.2 The web plate is to be stiffened at openings when the mean shear stress, as determined by application of the requirements of Section 8 or Section 9/2, is greater than 50N/mm^2 for acceptance criteria set AC1 or greater than 60N/mm^2 for acceptance criteria set AC2. The stiffening arrangement is to ensure buckling strength as required by Section 10 under application of the loading as required in Section 8 or Section 9/2.

3.5.4.3 On members contributing to longitudinal strength, stiffeners are to be fitted along the free edges of the openings parallel to the vertical and horizontal axis of the opening. Stiffeners may be omitted in one direction if the shortest axis is less than 400mm , and in both directions if length of both axes is less than 300mm . Edge reinforcement may be used as an alternative to stiffeners. See Fig. 4.3.8.

Fig. 4.3.8 Web Plate with Large Openings

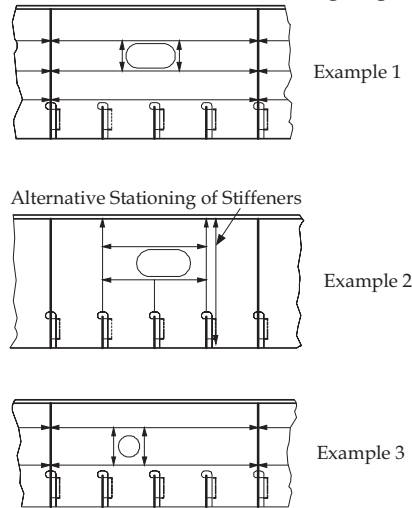

3.6 Local Reinforcement

3.6.1 Reinforcement at knuckles

3.6.1.1 Whenever a knuckle in a main member (shell, longitudinal bulkhead etc.) is arranged, adequate stiffening is to be fitted at the knuckle to transmit the transverse load. This stiffening, in the form of webs, brackets or profiles, is to be connected to the transverse members to which they are to transfer the load (in shear). See Fig. 4.3.9.

3.6.1.2 In general, for longitudinal shallow knuckles, closely spaced carlings are to be fitted across the knuckle, between longitudinal members above and below the knuckle. Carlings or other types of reinforcement need not be fitted in way of shallow knuckles that are not subject to high lateral loads and/or high in-plane loads across the knuckle, such as deck camber knuckles.

3.6.1.3 Generally, the distance between the knuckle and the support stiffening described in 3.6.1.1 is not to be greater than 50mm.

Fig. 4.3.9 Example of Reinforcement at Knuckles

Section, in way of typical hopper

Horizontal girder at upper hopper knuckle

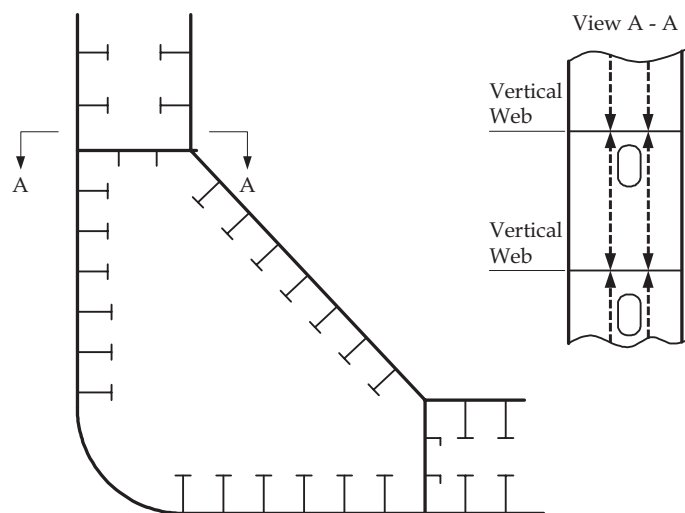

3.6.2 Reinforcement for openings and attachments associated with means of access for inspection purposes

3.6.2.1 Local reinforcement is to be provided taking into account proper location and strength of all attachments to the hull structure for access for inspection purposes.

3.7 Fatigue Strength

3.7.1 General

3.7.1.1 Structural details are to be designed for compliance with the requirements of fatigue strength as specified in **Section 9/3**.

Section 5 STRUCTURAL ARRANGEMENT

1. General

1.1 Introduction

1.1.1 Scope

1.1.1.1 This section covers the general structural arrangement requirements for the ship, which are based on or derived from National and International regulations, see **Section 2/2.1.1**.

2. Watertight Subdivision

2.1 Watertight Bulkhead Arrangement

2.1.1 General

2.1.1.1 All ships are to be provided with watertight bulkheads arranged to subdivide the hull into watertight compartments in accordance with the following requirements.

2.1.2 Minimum number and disposition of watertight bulkheads

2.1.2.1 The following watertight bulkheads are to be fitted on all ships:

- (a) a collision bulkhead, see **2.2.1.1**
- (b) an aft peak bulkhead
- (c) a bulkhead at each end of the machinery space.

2.1.2.2 The bulkheads in the cargo tank region are to be spaced at uniform intervals so far as practicable.

2.1.2.3 The applicable number and disposition of bulkheads are to be arranged to suit the requirements for subdivision, floodability and damage stability, and are to be in accordance with the requirements of National regulations.

2.1.2.4 The number of openings in watertight bulkheads is to be kept to a minimum. Where penetrations of watertight bulkheads and internal decks are necessary for access, piping, ventilation, electrical cables, etc., arrangements are to be made to maintain the watertight integrity. Additional requirements apply to collision bulkheads in **Section 8/3.6.2**.

2.2 Position of Collision Bulkhead

2.2.1 General

2.2.1.1 A collision bulkhead is to be fitted on all ships and is to extend to the freeboard deck. It is to be located between $0.05L_L$ or $10m$, whichever is less, and $0.08 L_L$ aft of the reference point, where the load line length, L_L , is as defined in **Section 4/1.1.2.1** and the reference point is as defined in **2.2.1.2**. Proposals for location of the collision bulkhead aft of $0.08 L_L$ will be specially considered.

2.2.1.2 For ships without bulbous bows the reference point is to be taken where the forward end of L_L coincides with the forward side of the stem, on the waterline which L_L is measured. For ships with bulbous bows, it is to be measured from the forward end of L_L a distance x forward; where x is to be taken as the lesser of the following:

- (a) half the distance, from the forward end of L_L and the extreme forward end of the bulb extension
- (b) $0.015 L_L$
- (c) $3.0m$.

2.2.1.3 In general, the collision bulkhead is to be in one plane, however, the bulkhead may have steps or recesses provided they are in compliance with the limits prescribed in **2.2.1.1** and **2.2.1.2**.

2.3 Position of Aft Peak Bulkhead

2.3.1 General

2.3.1.1 An aft peak bulkhead, enclosing the stern tube and rudder trunk in a watertight compartment, is to be provided. Where the shafting arrangements make enclosure of the stern tube in a watertight compartment impractical, alternative arrangements will be specially considered. The aft peak bulkhead location on ships powered and/or controlled by equipment that do not require the fitting of a stern tube and/or rudder trunk will also be subject to special consideration.

2.3.1.2 The aft peak bulkhead may terminate at the first deck above the summer load waterline, provided that this deck is made watertight to the stern or to a watertight transom floor.

3. Double Hull Arrangement

3.1 General

3.1.1 Protection of cargo tanks

3.1.1.1 Every tanker is to be provided with double bottom tanks and spaces, and double side tanks and spaces, in accordance with 3.2 and 3.3. The double bottom and double side tanks and spaces, protect the cargo tanks or spaces, and are not to be used for the carriage of oil cargoes.

3.1.2 Capacity of ballast tanks

3.1.2.1 The capacity of the segregated ballast tanks shall be so determined that the ship may operate safely on ballast voyages without recourse to the use of cargo tanks for water ballast. The capacity of ballast shall be at least such that, in any ballast condition at any part of the voyage, including the conditions consisting of lightweight plus segregated ballast only, the ships draught and trim can meet the requirements in 3.1.2.2 to 3.1.2.4.

3.1.2.2 The moulded draught amidships, T_{mid} , excluding any hogging or sagging correction, is not to be less than:

$$T_{mid} = 2.0 + 0.02L_{CSR-T} \quad (m)$$

Where:

L_{CSR-T} : rule length, as defined in Section 4/1.1.1.1, in m

3.1.2.3 The draughts at the F.P. and A.P. are to correspond to those determined by the draught amidships, as given in 3.1.2.2, and in association with a trim by the stern not greater than $0.015L_{CSR-T} (m)$.

3.1.2.4 The draught at the A.P. is not to be less than that required to obtain full immersion of the propeller(s).

3.1.3 Limitation of size and arrangement of cargo tanks

3.1.3.1 Cargo tanks are to be of a size and arrangement that hypothetical oil outflow from side and bottom damage, anywhere in the length of the ship, is limited.

3.2 Double Bottom

3.2.1 Double bottom depth

3.2.1.1 The minimum double bottom depth, d_{db} , is to be taken as the lesser of:

$$d_{db} = \frac{B}{15} \quad (m), \text{ but not less than } 1.0m$$

$$d_{db} = 2.0 \quad (m)$$

Where:

B : moulded breadth, in m , as defined in Section 4/1.1.3.1

3.3 Double Side

3.3.1 Double side width

3.3.1.1 The minimum double side width, w_{ds} , is to be taken as the lesser of:

$$w_{ds} = 0.5 + \frac{DWT}{20000} \quad (m), \text{ but not less than } 1.0m$$

$$w_{ds} = 2.0 \quad (m)$$

Where:

DWT : deadweight of the ship, in *tonnes*, as defined in Section 4/1.1.14.1

4. Separation of Spaces

4.1 Separation of Cargo Tanks

4.1.1 General

4.1.1.1 The cargo pump room, cargo tanks, slop tanks and cofferdams are to be positioned forward of machinery spaces. Main cargo control stations, control stations, accommodation and service spaces are to be positioned aft of cargo tanks, slop tanks, and spaces which isolate cargo or slop tanks from machinery spaces, but not necessarily aft of the oil fuel bunker tanks and ballast tanks.

4.2 Cofferdam Spaces

4.2.1 General

4.2.1.1 Cofferdam spaces are to be kept gas-tight. Where applicable, access requirements to permit internal inspections, are to be in accordance with **5.1**.

5. Access Arrangements

5.1 Access Into and Within Spaces in, and Forward of, the Cargo Tank Region

5.1.1 General

5.1.1.1 Access into and within spaces in, and forward of, the cargo tank region is to satisfy the requirement of **Chapter 35, Part C** of the Rules, for details and arrangements of openings and attachments to the hull structure. This will be reviewed in conjunction with the structural requirements. In addition, the requirements of **5.1.1.2** to **5.1.1.5** are to be complied with.

5.1.1.2 Where a duct keel or pipe tunnel is fitted provision is to be made for at least two exits to the open deck arranged at a maximum distance from each other. The duct keel or pipe tunnel is not to pass into machinery spaces. The aft access may lead from the pump room to the duct keel. Where an aft access is provided from the pump room to the duct keel, the access opening from the pump room to the duct keel is to be provided with an oil-tight cover plate or a watertight door. Mechanical ventilation is to be provided and such spaces are to be sufficiently ventilated prior to entry. A notice board is to be fitted at each entrance to the pipe tunnel stating that before any attempt is made to enter, the ventilating fan must have been in operation for a sufficient period. In addition, the atmosphere in the tunnel is to be sampled by a gas monitor, and where an inert gas system is fitted in cargo tanks, an oxygen monitor is to be provided.

5.1.1.3 Where a watertight door is fitted in the pump room for access to the duct keel, the scantlings of the watertight door are to comply with the requirements of the Society and the following additional requirements:

- (a) the watertight door is to be capable of being manually closed from outside the main pump room entrance, in addition to bridge operation. A means of indicating whether the door is open or closed is to be provided locally and on the bridge.
- (b) a notice is to be affixed at each operating position to the effect that the watertight door is to be kept closed during normal operations of the ship, except when access to the pipe tunnel is required.

5.1.1.4 At least one horizontal access opening of 600mm by 800mm clear opening is to be fitted in each horizontal girder in the vertical wing ballast space and weather deck to assist in rescue operations. Where an opening of 600mm by 800mm is not permitted due to structural arrangements, a 600mm by 600mm clear opening will be accepted.

5.1.1.5 Special consideration will be given to any proposals to fit permanent repair/maintenance access openings with oil-tight covers in cargo tank bulkheads. Attention is drawn to the relevant National regulations concerning load line and oil outflow aspects of such arrangements.

Section 6 MATERIALS AND WELDING

1. Steel Grades

1.1 Hull Structural Steel

1.1.1 Scope

1.1.1.1 Materials used during construction are to comply with **Part C** and **Part K** of the Rules. Use of other materials and the corresponding scantlings will be specially considered.

1.1.2 Strength

1.1.2.1 Steel having a specified minimum yield stress of 235N/mm^2 is regarded as normal strength hull structural steel. Steel having a higher specified minimum yield stress is regarded as higher strength hull structural steel.

1.1.3 Material grades

1.1.3.1 Material grades of hull structural steels are referred to as follows:

- (a) *A*, *B*, *D* and *E* denote normal strength steel grades
- (b) *AH*, *DH* and *EH* denote higher strength steel grades.

1.1.4 Higher strength steel factor

1.1.4.1 For the determination of hull girder section modulus, where higher strength hull structural steel is used, a higher strength steel factor, *k* is given in **Table 6.1.1**.

Table 6.1.1 Values of *k*

Specified minimum yield stress, N/mm^2	<i>k</i>
235	1.00
265	0.93
315	0.78
340	0.74
355	0.72
390	0.68

Note

1. Intermediate values are to be calculated by linear interpolation.

1.1.5 Through thickness property

1.1.5.1 Where tee or cruciform connections employ partial or full penetration welds, and the plate material is subject to significant tensile strain in a direction perpendicular to the rolled surfaces, consideration is to be given to the use of special material with specified through thickness properties, in accordance with **3.11 Part K** of the Rules. These steels are to be designated on the approved plan by the required steel strength grade followed by the letter *Z* (e.g. *EH36 Z*).

1.1.6 Steel castings and forgings

1.1.6.1 Steel castings or forgings that are used for stern frames, rudder frames, rudder stocks, propeller shaft brackets and other major structural items are to be in accordance with **Chapter 5** and **Chapter 6, Part K** of the Rules.

1.2 Application of Steel Materials

1.2.1 Selection of material grades

1.2.1.1 Steel materials for particular locations are not to be of lower grades than those given in **Table 6.1.2** for the material class given in **Table 6.1.3**.

1.2.2 Applicable thickness

1.2.2.1 For application of **Table 6.1.2** and **Table 6.1.3**, the steel grade is to correspond to the as-built thickness.

1.2.3 Operation in areas with low air temperature

1.2.3.1 For ships intended to operate for long periods in areas with a lowest mean daily average temperature below -10 degrees C (i.e. regular service during winter to Arctic or Antarctic waters) the materials in exposed structures will be specially considered.

Table 6.1.2 Material Grades

Thickness, t in mm	Material Class		
	I	II	III
$t \leq 15$	<i>A, AH</i>	<i>A, AH</i>	<i>A, AH</i>
$15 < t \leq 20$	<i>A, AH</i>	<i>A, AH</i>	<i>B, AH</i>
$20 < t \leq 25$	<i>A, AH</i>	<i>B, AH</i>	<i>D, DH</i>
$25 < t \leq 30$	<i>A, AH</i>	<i>D, DH</i>	<i>D, DH</i>
$30 < t \leq 35$	<i>B, AH</i>	<i>D, DH</i>	<i>E, EH</i>
$35 < t \leq 40$	<i>B, AH</i>	<i>D, DH</i>	<i>E, EH</i>
$40 < t \leq 51$	<i>D, DH</i>	<i>E, EH</i>	<i>E, EH</i>

Table 6.1.3 Material Class or Grade of Structural Members

Structural member category	Material Class or Grade	
	Within $0.4L_{CSR-T}$ Amidships	Outside $0.4L_{CSR-T}$
Secondary Longitudinal bulkhead strakes, other than those belonging to primary category Deck plating exposed to weather other than that belonging to primary or special category Side plating	Class I	Grade $A^{(8)}/AH$
Primary Bottom plating including keel plate Strength deck plating, excluding that belonging to the special category ⁽¹⁰⁾⁽¹¹⁾ Continuous longitudinal members above strength deck, excluding longitudinal hatch coamings Uppermost strake in longitudinal bulkheads ⁽¹⁰⁾⁽¹¹⁾ Vertical strake (hatch side girder) and upper sloped strake in top wing tank	Class II	Grade $A^{(8)}/AH$
Special Sheer strake at strength deck ⁽¹⁾⁽²⁾⁽³⁾⁽¹⁰⁾⁽¹¹⁾ Stringer plate in strength deck ⁽¹⁾⁽²⁾⁽³⁾⁽¹⁰⁾⁽¹¹⁾ Deck strake at longitudinal bulkhead, excluding deck plating in way of inner hull longitudinal bulkhead ⁽²⁾⁽⁴⁾⁽¹⁰⁾⁽¹¹⁾ Strength deck plating at outboard corners of cargo hatch openings ⁽¹¹⁾ Bilge strake ⁽²⁾⁽⁶⁾ Continuous longitudinal hatch coamings ⁽¹¹⁾	Class III	Class II (Class I outside $0.6L_{CSR-T}$ amidships)
Other Categories Plating for stern frames, rudder horns and shaft brackets Longitudinal strength members of strength deck plating for ships with single strength deck ⁽¹¹⁾ Strength members not referred to in above categories ⁽⁹⁾	– Grade B/AH Grade $A^{(8)}/AH$	Class II – Grade $A^{(8)}/AH$

Notes

- Not to be less than E/EH within $0.4L_{CSR-T}$ amidships in vessels with length, L_{CSR-T} , exceeding 250m.
- Single strakes required to be of material class III or E/EH are, within $0.4L_{CSR-T}$ amidships, to have breadths not less than $800 + 5L_{CSR-T} mm$, but need not be greater than 1800mm.
- A radius gunwale plate may be considered to meet the requirements for both the stringer plate and the sheer strake, provided it extends generally 600mm inboard and vertically.
- For tankers having a breadth, B , exceeding 70m, the centreline strake and the strakes in way of the longitudinal bulkheads port and starboard, are to be class III.
- (Void)
- To be not lower than D/DH within $0.6L_{CSR-T}$ amidships of vessels with length, L_{CSR-T} , exceeding 250m.
- (Void)
- Grade B/AH to be used for plate thickness more than 40mm. For engine foundation heavy plates, Grade B/AH to be used for plate thickness more than 30mm. However, engine foundation heavy plates outside $0.6L_{CSR-T}$ amidships may be of Grade A/AH .
- The material class used for reinforcement and the quality of material (i.e. whether normal or higher strength steel) used for welded attachments, such as spill protection bars and bilge keel, is to be similar to that of the hull envelope plating in way. Where attachments are made to round gunwale plates, special consideration will be given to the required grade of steel, taking account of the intended structural arrangements and attachment details.

10. The material class for deck plating, sheer strake and upper strake of longitudinal bulkhead within $0.4L_{CSR-T}$ amidships is also to be applied at structural breaks of the superstructure, irrespective of position.
11. To be not lower than B/AH within $0.4L_{CSR-T}$ amidships for ships with single strength deck.

1.2.4 Guidance for repairs

1.2.4.1 Where materials are used in the construction, which are not in accordance with **Part K** of the Rules, a set of plans showing the following information, for each material, is to be placed aboard the vessel in addition to those normally retained on the vessel:

- (a) material specification and applicable thickness
- (b) welding procedure
- (c) location and extent of application.

1.3 Aluminium Alloys

1.3.1 General

1.3.1.1 The use of aluminium alloys in superstructures, deckhouses, hatch covers, helicopter platforms, or other local components will be specially considered. A specification of the proposed alloys and their proposed method of fabrication is to be submitted for approval.

1.3.1.2 Details of the proposed method of joining any aluminium and steel structures are to be submitted for approval.

1.3.1.3 Material requirements and scantlings are to comply with **Part C** and **Part K** of the Rules.

1.3.2 Incendiary sparking on impact with steel

1.3.2.1 Aluminium may, under certain circumstances give rise to incendiary sparking on impact with oxidized steel. A particular risk is where an aluminium component is dragged or rubbed against the uncoated steel structure creating a thin smear of aluminium on the surface. Subsequent high energy impact by a rusted component on that smear could generate an incendiary spark capable of igniting any surrounding inflammable gas. The following requirements are therefore to be complied with:

- (a) aluminium fittings in tanks used for the carriage of oil, and in cofferdams and pump rooms are to be avoided
- (b) where fitted, aluminium fittings, units and supports, in tanks used for the carriage of oil, cofferdams and pump rooms are to satisfy the requirements of **2.1.2** for aluminium anodes
- (c) the underside of heavy portable aluminium structures such as gangways, etc., is to be protected by means of a hard plastic or wood cover, or other approved means, in order to avoid the creation of smears. Such protection is to be permanently and securely attached to the structures.

2. Corrosion Protection Including Coatings

2.1 Hull Protection

2.1.1 General

2.1.1.1 All dedicated seawater ballast tanks are to have an efficient corrosion prevention system, as required by **Chapter 25, Part C** of the Rules, see **Section 2/2.1.1**.

2.1.1.2 For ships contracted for construction on or after 8 December 2006, the date of IMO adoption of the amended *SOLAS Regulation II-1/3-2*, by which an IMO “Performance standard for protective coatings for ballast tanks and void spaces” will be made mandatory, the coatings of internal spaces subject to the amended *SOLAS Regulation* are to satisfy the requirements of the IMO performance standard. For ships contracted for construction on or after 1 July 2012, the IMO performance standard is to be applied as interpreted by *IACS UI SC 223* and *IACS UI SC 227*. In applying *IACS UI SC 223*, “Administration” is to be read to be the “Classification Society”.

2.1.1.3 Consistent with *IMO Resolution A.798(19)* and *IACS UI SC 122*, the selection of the coating system, including coating selection, specification, and inspection plan, are to be agreed between the shipbuilder, coating system supplier and the owner, in consultation with the Society, prior to commencement of construction. The specification for the coating system for these spaces is to be documented and this documentation is to be verified by the Society and is to be in full compliance with the coating performance standard.

2.1.1.4 The shipbuilder is to demonstrate that the selected coating system with associated surface preparation and application methods is compatible with the manufacturing processes and methods.

2.1.1.5 The shipbuilder is to demonstrate that the coating inspectors have proper qualification as required by the IMO standard.

2.1.1.6 The attending surveyor of the Society will not verify the application of the coatings but will review the reports of the coating inspectors to verify that the specified shipyard coating procedures have been followed.

2.1.1.7 Where anodes are fitted in ballast tanks, ballast tank anode distribution drawings are to be submitted for approval. Such drawings are to include details of the connections to the hull, e.g. welding details.

2.1.1.8 The corrosion protection for all cargo oil tanks is to be in accordance with **Chapter 25, Part C**.

2.1.2 Internal cathodic protection systems

2.1.2.1 When a cathodic protection system is to be fitted to steel structures in tanks used for liquid cargo with flash point below 60°C, a plan of the fitting arrangement is to be submitted for approval. The arrangements will be considered for safety against fire and explosion. This approval also applies to adjacent tanks.

2.1.2.2 Permanent anodes in tanks made of, or alloyed with magnesium are not acceptable, except in tanks solely intended for water ballast that are not adjacent to cargo tanks. Impressed current systems are not to be used in cargo tanks due to the development of chlorine and hydrogen that can result in an explosion. Aluminium anodes are accepted, however, in tanks with liquid cargo with flash point below 60°C and in adjacent ballast tanks, aluminium anodes are to be located so a kinetic energy of not more than 275J is developed in the event of their loosening and becoming detached.

2.1.2.3 Aluminium anodes are to be located in such a way that they are protected from falling objects. They are not to be located under tank hatches or Butterworth openings unless protected by adjacent structure.

2.1.2.4 All anodes are to be attached to the structure in such a way that they will remain securely fastened both initially and during service. The following methods are acceptable:

- (a) steel core connected to the structure by continuous fillet welds of sufficient cross section
- (b) attachment by properly secured through-bolts or other positive locking devices. Attachment by clamps fixed with setscrews is to be by approved means.

2.1.2.5 Anode steel cores bent and directly welded to the steel structure are to be of a material complying with the requirements for grade *A* of **Part K** of the Rules.

2.1.2.6 Anodes are to be attached to stiffeners or aligned in way of stiffeners on plane bulkhead plating, but they are not to be attached to the shell. The two ends are not to be attached to separate members which are capable of relative movement.

2.1.2.7 Where cores or supports are welded to local support members or primary support members, they are to be kept clear of end supports, toes of brackets and similar stress raisers. Where they are welded to asymmetrical members, the welding is to be at least *25mm* away from the edge of the web. In the case of stiffeners or girders with symmetrical face plates, the connection may be made to the web or to the centreline of the face plate, but well clear of the free edges. Generally, anodes are not to be fitted to a face plate of higher strength steel.

2.1.2.8 Tanks in which anodes are installed, are to have sufficient holes for the circulation of air to prevent gas from collecting in pockets.

2.1.3 Paint containing aluminium

2.1.3.1 Paint containing aluminium is not to be used in positions where cargo vapours may accumulate unless it has been shown by appropriate tests that the paint to be used does not increase the incendiary sparking hazard. Tests need not be performed for coatings with less than *10 percent* aluminium by weight.

3. Corrosion Additions

3.1 General

3.1.1 Introduction

3.1.1.1 The required net thickness of steel structures is to be increased by the corrosion addition as specified in this Sub-Section.

3.1.1.2 The corrosion additions given in this Sub-Section are applicable to carbon-manganese steels, see **1.1**. Application of corrosion additions for other materials, such as stainless steel, is to be in accordance with the requirements of the Society.

3.1.1.3 The application of the corrosion additions in rule calculations is given in **3.3**.

3.2 Local Corrosion Additions

3.2.1 General

3.2.1.1 The local corrosion additions, t_{corr} , for structural members are to be taken as:

$$t_{corr} = t_{was} + 0.5 \quad (mm)$$

Where:

t_{was} : total wastage allowance of the considered structural member, in *mm*,
as given in **Section 12/1.4.2.2**

3.2.1.2 The local corrosion additions, t_{corr} , for typical structural elements in the cargo tank region are given in **Table 6.3.1** and **Fig. 6.3.1**.

Table 6.3.1 Corrosion Addition, t_{corr} , for Typical Structural Elements Within the Cargo Tank Region

Category of contents			Corrosion Addition t_{corr} in <i>mm</i>
Internal members and plate boundary between spaces with the same category of contents			
In and between ballast water tanks	Face plate of PSM	Within 3 <i>m</i> below top of tank ⁽¹⁾	4.5
		Elsewhere	3.5
	Other members	Within 3 <i>m</i> below top of tank ⁽¹⁾	4.0
		Elsewhere	3.0
	Stiffeners on boundaries to heated cargo tanks	Within 3 <i>m</i> below top of tank ⁽¹⁾	4.5
		Elsewhere	3.5
In and between cargo oil tanks	Face plate of PSM	Within 3 <i>m</i> below top of tank ⁽¹⁾	4.0
		Elsewhere	3.5
	Other members	Within 3 <i>m</i> below top of tank ⁽¹⁾	4.0
		Elsewhere	2.5
Exposed to atmosphere on both sides	Support members on deck		2.5
In and between void spaces	Spaces not normally accessed, e.g. access only via bolted manhole openings, pipe tunnels, etc.		2.0
In and between dry spaces	Internals of deckhouses, machinery spaces, pump room, store rooms, steering gear space, etc.		1.5
Plate boundary between spaces having a different category			
Boundary between ballast tank and cargo oil tank	Unheated cargo tank	Within 3 <i>m</i> below top of tank ⁽¹⁾	4.0
		Inner bottom plating	4.0
		Elsewhere	3.0
	Heated cargo tank	Within 3 <i>m</i> below top of tank ⁽¹⁾	4.5
		Inner bottom plating	4.5
		Elsewhere	3.5
Boundary between ballast tank and atmosphere or sea	Weather deck plating		4.0
	Other members ⁽²⁾	Within 3 <i>m</i> below top of tank ⁽¹⁾	3.5
		Elsewhere	3.0
Boundary between ballast tank and void or dry space	Within 3 <i>m</i> below top of tank ⁽¹⁾		3.0
	Elsewhere		2.5
Boundary between cargo tank and atmosphere	Weather deck plating		4.0
Boundary between cargo tank and void spaces	Within 3 <i>m</i> below top of tank ⁽¹⁾		3.0
	Elsewhere		2.5
Boundary between cargo tank and dry spaces	Within 3 <i>m</i> below top of tank ⁽¹⁾		3.0
	Elsewhere		2.0

Notes

- (1) Only applicable to cargo and ballast tanks with weather deck as the tank top
- (2) 0.5*mm* to be added for side plating in the quay contact region defined in **Section 8/Fig. 8.2.2**
- (3) Heated cargo oil tanks are defined as cargo tanks arranged with any form of heating capability

Fig. 6.3.1 Corrosion Addition, t_{corr} , for Typical Structural Elements Within the Cargo Tank

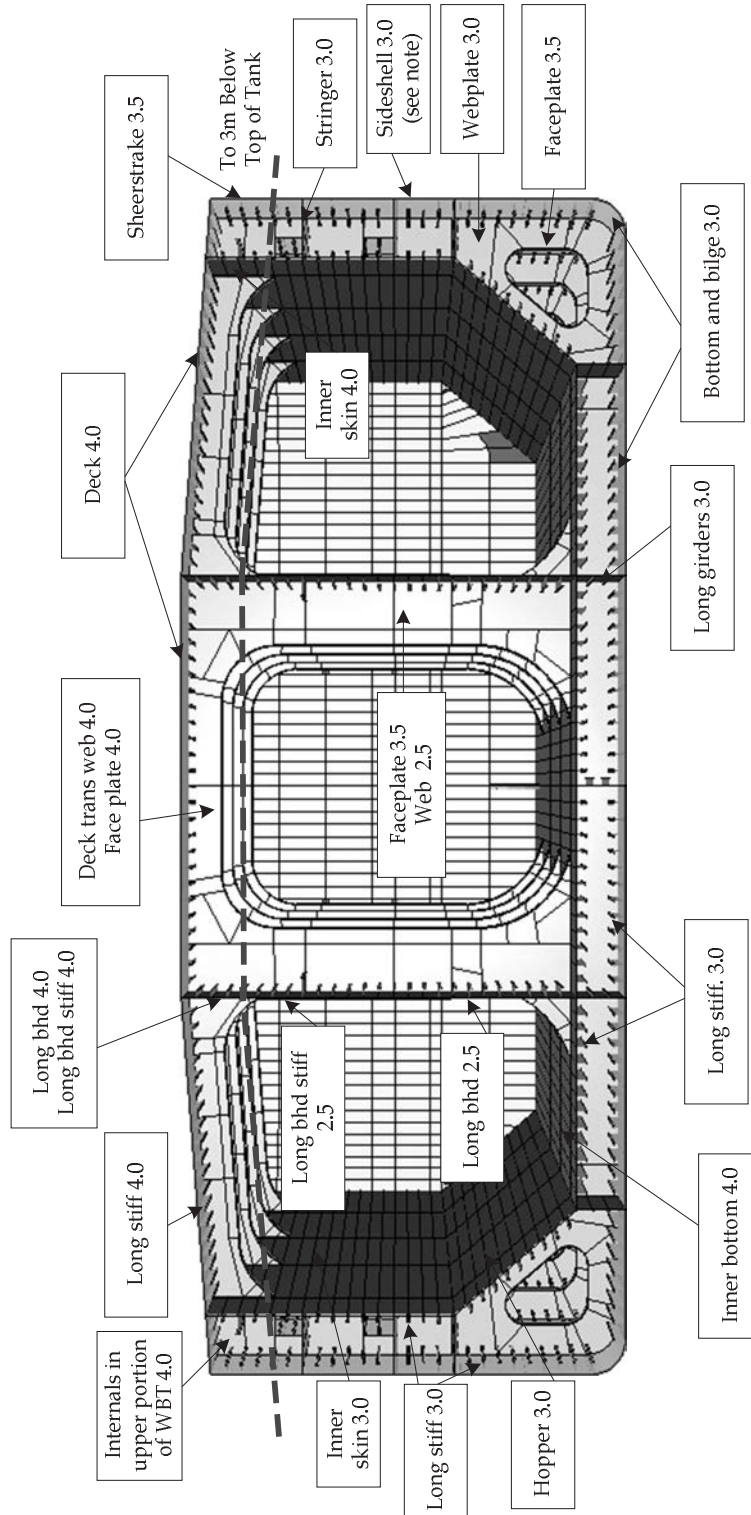

Note

1. Corrosion additions are given for a standard configuration and without heated cargo
2. 0.5mm to be added for side plating in the quay contact region defined in Section 8/ Fig. 8.2.2
3. The distance 3m below top of tank is to be measure parallel to the deck

3.3 Application of Corrosion Additions

3.3.1 General

3.3.1.1 The application of corrosion additions described in 3.3.2 to 3.3.7 is to be applied unless otherwise specified in the specific rule requirements.

3.3.1.2 Compliance with this part may be performed either by:

- (a) comparison of the proposed gross scantling with the gross required, in which case the applicable corrosion addition is added to the net requirement of this part.
- (b) comparison of the proposed net scantling with the net required, in which case the applicable corrosion addition is deducted from the gross proposed.

Methods (a) and (b) are suitable for assessment of thickness. Method (b) is the most suitable for assessment of section properties, e.g. section modulus, area and moment of inertia.

3.3.1.3 The gross scantlings specified in 3.3.2 to 3.3.7 used to derive the net scantlings are to exclude any owner's extra thicknesses, see also Section 2/4.3.4.3.

3.3.2 Application for hull girder longitudinal strength calculations

3.3.2.1 The calculation of hull girder stresses for the assessment of longitudinal strength as given in Section 8/1 is to be based on the net hull girder sectional properties calculated by deducting half the corrosion addition, i.e. $-0.5t_{corr}$, from the gross thickness of all structural elements comprising the hull girder cross-section.

3.3.2.2 The local buckling capacity of plates and stiffeners subject to hull girder stresses are to be calculated based on the net scantlings, as given in Section 8/1.4.2. The net scantling is calculated by deducting the full corrosion addition, i.e. $-1.0t_{corr}$, from the gross thickness.

3.3.3 Application for scantling strength assessment of plates and local support members

3.3.3.1 The required gross thickness for plates and local support members are calculated by adding the full corrosion addition, i.e. $+1.0t_{corr}$, to the net thickness required in accordance with the scantling requirements in Sections 4/3.4 and 8/2 to 8/7.

3.3.3.2 The net sectional properties of local support members are calculated by deducting the full corrosion addition, i.e. $-1.0t_{corr}$, from the web, flange and attached plate gross thicknesses as described in Section 4/2.4.1 and are to comply with required section modulus, moment of inertia and shear area as given in Sections 4/3.4 and 8/2 to 8/7.

3.3.3.3 The calculation of hull girder stresses for the strength assessment of members under combined local and global loading is to be based on the net hull girder sectional properties calculated by deducting half the corrosion addition, i.e. $-0.5t_{corr}$, from the gross thickness of all structural elements comprising the hull girder cross-section.

3.3.3.4 The required minimum gross thickness of plates and local support members is calculated by adding the full corrosion addition, i.e. $+1.0t_{corr}$, to the minimum net thickness requirements given in Section 8/2.1.5.

3.3.4 Application of corrosion additions for scantling strength assessment of primary support members

3.3.4.1 The required gross thickness of primary support members is calculated by adding half the corrosion addition, i.e. $+0.5t_{corr}$, to the net thickness required in accordance with the strength requirements in Section 8/2.6 and 8/3 to 8/7.

3.3.4.2 The net sectional properties of primary support members are to be calculated by deducting half the corrosion addition, i.e. $-0.5t_{corr}$, from the web and flange gross thicknesses, and are to comply with the required section modulus, moment of inertia and area as given in Section 8/2.6 and 8/3 to 8/7.

3.3.4.3 The required minimum gross thickness of primary support members is calculated by adding the full corrosion addition, i.e. $+1.0t_{corr}$, to the minimum net thickness requirement given in Section 8/2.1.6.1, 8/3.1.4.1, 8/4.1.5.1, 8/5.1.4.1, 8/6.3.7.5, 8/6.4.5.4 and 10/2.3.

3.3.5 Application of corrosion additions for hull girder ultimate strength analysis

3.3.5.1 The calculation of the hull girder ultimate capacity, M_u , as given in Section 9/1, is to be based on the net hull girder sectional properties calculated by deducting half the corrosion addition, i.e. $-0.5t_{corr}$, from the gross thickness of all structural elements comprising the hull girder cross-section.

3.3.5.2 The buckling capacity of the structural elements used to derive the hull girder ultimate capacity is to be calculated by deducting half the corrosion addition, i.e. $-0.5t_{corr}$, from the gross thicknesses of the plates and stiffener webs and flanges.

3.3.6 Application of corrosion additions for strength assessment by finite element analysis

3.3.6.1 For the cargo tank structural strength analysis, as given in **Section 9/2.2** and **Appendix B/2**, the finite element model is to be modelled with thicknesses calculated by deducting half the corrosion addition, i.e. $-0.5t_{corr}$, from the gross thickness of all structural elements.

3.3.6.2 The local buckling capacity of plates and stiffeners are to be calculated by deducting the full corrosion addition, i.e. $-1.0t_{corr}$, from the gross thickness.

3.3.6.3 The local fine mesh structural strength analysis models, as given in **Section 9/2.3** and **Appendix B/3**, are to be modelled with thicknesses calculated by deducting half the corrosion addition, i.e. $-0.5t_{corr}$, from the gross thickness. The specified fine mesh areas are to be modelled by deduction of the full corrosion addition, i.e. $-1.0t_{corr}$, from the gross thickness.

3.3.7 Application of corrosion additions for fatigue strength assessment

3.3.7.1 The calculation of hull girder stresses for the fatigue strength assessment, as given in **Section 9/3** and **Appendix C/1**, is to be based on the net fatigue hull girder sectional properties, calculated by deducting a quarter of the corrosion addition, i.e. $-0.25t_{corr}$, from the gross thickness of all structural elements comprising the hull girder cross section.

3.3.7.2 The calculation of stresses in local support members from lateral load for the fatigue strength assessment, as given in **Section 9/3** and **Appendix C/1**, are to be based on deducting half the corrosion addition, i.e. $-0.5t_{corr}$, from the stiffener web, flange and attached plate.

3.3.7.3 For hot spot stress (FE based) approach, as given in **Section 9/3** and **Appendix C/2**, the FE model of the hopper knuckle is to be modelled with thickness calculated by deducting a quarter of the corrosion addition, i.e. $-0.25t_{corr}$, from the gross thicknesses. The very fine mesh areas are to be modelled by deduction of half the corrosion addition, i.e. $-0.5t_{corr}$, from the gross thickness.

3.3.7.4 As an alternative to **3.3.7.3**, the hopper fatigue FE model may be made in accordance with requirements for FE strength model, i.e. all areas at $-0.5t_{corr}$, as described in **3.3.6.1**. However the calculated stress range is then to be corrected by the factor f_{model} as described in **Appendix C/2.4.2.7**.

4. Fabrication

4.1 General

4.1.1 Workmanship

4.1.1.1 All workmanship is to be of commercial marine quality and acceptable to the Surveyor. Welding is to be in accordance with the requirements of **Sub-Section 5**. Any defect is to be rectified to the satisfaction of the Surveyor before the material is covered with paint, cement or any other composition.

4.1.2 Fabrication standard

4.1.2.1 Structural fabrication is to be carried out, in accordance with '*IACS Recommendation 47, Shipbuilding and Repair Quality Standard for New Construction*' or a recognised fabrication standard which has been accepted by the Society prior to the commencement of fabrication/construction.

4.1.2.2 The fabrication standard to be used during fabrication/construction is to be made available to the attending representative of the Society, prior to the commencement of the fabrication/construction.

4.1.2.3 The fabrication standard is to include information, to establish the range and the tolerance limits, for the items specified as follows:

- (a) Cutting edge
 - the slope of the cut edge and the roughness of the cut edges
- (b) Flanged longitudinals and brackets and built-up sections
 - the breadth of flange and depth of web, angle between flange and web, and straightness in plane of flange or at the top of face plate
- (c) Pillars
 - the straightness between decks, and cylindrical structure diameter
- (d) Brackets and small stiffeners
 - the distortion at the free edge line of tripping brackets and small stiffeners
- (e) Sub-assembly stiffeners
 - details of snipe end of secondary face plates and stiffeners
- (f) Plate assembly
 - for flat and curved blocks the dimensions (length and breadth), distortion and squareness, and the deviation of interior members from the plate
- (g) Cubic assembly
 - in addition to the criteria for plate assembly, twisting deviation between upper and lower plates, for flat and curved cubic blocks
- (h) Special assembly
 - the distance between upper and lower gudgeons, distance between aft edge of propeller boss and aft peak bulkhead, twist of stern frame assembly, deviation of rudder from shaft centreline, twist of rudder plate, and flatness, breadth and length of top plate of main engine bed. Where boring out of the propeller boss and stern frame, skeg or solepiece is carried out at a late stage of construction, it is to be carried out after completing the major part of the welding of the aft part of the ship. Where block boring is used, the shaft alignment is to be carried out using a method and sequence submitted to and recognized by the Classification Society. The fit-up and alignment of the rudder, pintles and axles, are to be carried out after completing the major part of the welding of the aft part of the ship. The contacts between the conical surfaces of pintles, rudder stocks and rudder axles are to be checked before the final mounting.
- (i) Butt joints in plating
 - alignment of butt joint in plating
- (j) Cruciform joints
 - alignment measured on the median line and measured on the heel line of cruciform joints
- (k) Alignment of interior members
 - alignments of flange of T longitudinals, alignment of panel stiffeners, gaps in T joints and lap joints, and

distance between scallop and cut outs for continuous stiffeners in assembly and in erection joints

- (l) Keel and bottom sighting
 - deflections for whole length of the ship, and for the distance between two adjacent bulkheads, cocking-up of fore body and of aft body, and rise of floor amidships
- (m) Dimensions
 - dimensions of length between perpendiculars, moulded breadth and depth at midship, and length between aft edge of propeller boss and main engine
- (n) Fairness of plating between frames
 - deflections between frames of shell, tank top, bulkhead, upper deck, superstructure deck, deck house deck and wall plating
- (o) Fairness of plating in way of frames
 - deflections of shell, tank top, bulkhead, strength deck plating and other structures measured in way of frames

4.2 Cold Forming

4.2.1 Special structural members

4.2.1.1 For highly stressed components of the hull girder where notch toughness is of particular concern (e.g. items required to be Class III in **Table 6.1.3**, such as radius gunwales and bilge strakes) the inside bending radius, in cold formed plating, is not to be less than 10 *times* the gross plate thickness for carbon-manganese steels (hull structural steels, see **1.1**). The allowable inside bending radius may be reduced below 10 *times* the gross plate thickness, providing the additional requirements stated in **4.2.3** are complied with.

4.2.2 Other members

4.2.2.1 For main structural members, e.g. corrugated bulkheads and hopper knuckles, the inside bending radius, in cold formed plating, is not to be less than 4.5 *times* the gross plate thickness for carbon-manganese steels (hull structural steels, see **1.1**). The allowable inside bending radius may be reduced below 4.5 *times* the gross plate thickness, providing the additional requirements stated in **4.2.3** are complied with.

4.2.3 Additional requirements

4.2.3.1 When steel is formed below 650°C with a radius of less than 10 or 4.5 *times* the gross plate thickness for special and other members, respectively, supporting data is to be provided. As a minimum, the following additional requirements are to be complied with:

- (a) the steel is to be of grade *D/DH* or higher
- (b) the material is impact tested in the strain-aged condition and satisfies the requirements stated herein. The deformation is to be equal to the maximum deformation to be applied during production, calculated by the formula $t_{grs} / (2r_{bdg} + t_{grs})$, where t_{grs} is the gross thickness of the plate material and r_{bdg} is the bending radius. One sample is to be plastically strained at the calculated deformation or 5%, whichever is greater and then artificially aged at 250°C for one hour then subject to Charpy V-notch testing. The average impact energy after strain ageing is to meet the impact requirements specified for the grade of steel used.
- (c) 100% visual inspection of the deformed area is to be carried out. In addition, random checks by magnetic particle testing are to be carried out.

The bending radius is in no case to be less than twice the gross plate thickness.

4.3 Hot Forming

4.3.1 Temperature requirements

4.3.1.1 Steel is not to be formed between the upper and lower critical temperatures. If the forming temperature exceeds 650°C for as-rolled, controlled rolled, thermo-mechanical controlled rolled or normalised steels, or is not at least 28°C lower than the tempering temperature for quenched and tempered steels, mechanical tests are to be made to assure that these temperatures have not adversely affected both the tensile and impact properties of the steel. Where curve forming or fairing, by line or spot heating, is carried out in accordance with **4.3.2.1** these mechanical tests are not required.

4.3.1.2 Confirmation is required to demonstrate the mechanical properties after further heating meet the requirements specified by a procedure test using representative material, when considering further heating other than in 4.3.1.1 of thermo-mechanically controlled steels (TMCP plates) for forming and stress relieving.

4.3.2 Line or spot heating

4.3.2.1 Curve forming or fairing, by linear or spot heating, is to be carried out using approved procedures in order to ensure that the properties of the material are not adversely affected. Heating temperature, on the surface, is to be controlled so as not to exceed the maximum allowable limit applicable to the plate grade.

4.4 Welding

4.4.1 General

4.4.1.1 All welding is to be carried out by approved welders, in accordance with approved welding procedures, using approved welding consumables and is to comply with the requirements of **Part M** of the Rules.

4.4.2 Welding sequence

4.4.2.1 Consideration is to be given to the assembly sequence and the effect on the overall shrinkage of plate panels, assemblies, etc., resulting from the welding processes employed. Welding is to proceed systematically, with each welded joint being completed in the correct sequence, without undue interruption.

4.4.2.2 Where practicable, welding is to commence at the centre of a joint and proceed outwards, or at the centre of an assembly and progress outwards towards the perimeter so that each part has freedom to move in one or more directions.

4.4.2.3 Generally, the welding of stiffener members, including transverses, frames, girders, etc., to welded plate panels by automatic processes is to be carried out in such a way as to minimize angular distortion of the stiffener.

4.4.3 Arrangements at junctions of welds

4.4.3.1 Welds are to be made flush in way of the faying surface where stiffening members, attached by continuous fillet welds, cross the completely finished butt or seam welds. Similarly, butt welds in webs of stiffening members are to be completed and made flush with the stiffening member before the fillet weld is made. The ends of the flush portion are to run out smoothly without notches or sudden changes of section. Where these conditions cannot be complied with, a scallop is to be arranged in the web of the stiffening member. Scallops are to be of a size, and in a position, that a satisfactory return weld can be made.

4.4.4 Leak stoppers

4.4.4.1 Where structural members pass through the boundary of a tank, leakage into the adjacent space could be hazardous or undesirable, and full penetration welding is to be adopted for the members for at least 150mm on each side of the boundary. Alternatively, a small scallop of suitable shape may be cut in the member close to the boundary outside of the compartment, and carefully welded all around.

5. Weld Design and Dimensions

5.1 General

5.1.1 Scope

5.1.1.1 In general, weld sizes are based on the Rule gross thickness values.

5.1.1.2 Requirements for welding sequence, qualification of welders, welding procedures and welding consumables are given in 4.4.

5.1.2 Plans and specifications

5.1.2.1 Plans and/or specifications showing weld sizes and weld details are to be submitted for approval for each new construction project.

5.1.2.2 Where reductions in weld sizes are proposed the requirements given in 5.9 are to be applied and the following details are to be included in the welding specification:

- (a) proposed weld gap size
- (b) proposed welding consumable.

5.1.3 Tolerance requirements

5.1.3.1 The gaps between the faying surfaces of members being joined are to be kept to a minimum or in accordance with approved specification.

5.1.3.2 Where the gap between the members joined by fillet welds exceeds $2mm$, the weld size is to be increased in accordance with 5.7.1.6.

5.1.4 Special precautions

5.1.4.1 Welding is to be based on approved welding procedure specifications where small fillets are used to attach heavy plates or sections. Special precautions, such as the use of preheating, low-hydrogen electrodes or low-hydrogen welding processes, are accepted.

5.1.4.2 When heavy structural members are attached to relatively light plating, the weld size and sequence may require modification.

5.2 Butt Joints

5.2.1 General

5.2.1.1 Joints in the plate components of stiffened panel structures are generally to be joined by butt welds. Typical types of butt welds with corresponding edge preparation are shown in **Fig. 6.5.1**.

5.2.1.2 All types of butt joints are to be welded from both sides. Before welding is carried out on the second side, unsound weld metal is to be removed at the root by a suitable method. Butt welding from one side will only be permitted for specific applications with an approved welding procedure specification.

Fig. 6.5.1 Typical Butt Welds

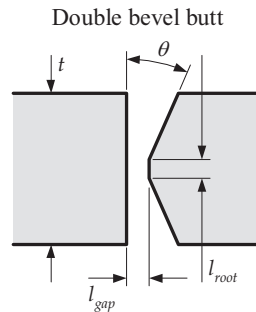
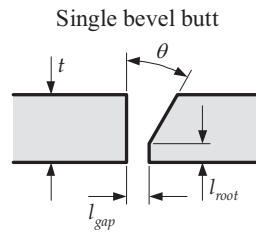

Double vee butt, uniform bevels

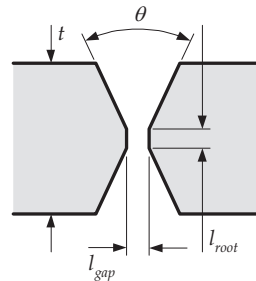

Single vee butt, one side welding with backing strip (temporary or permanent)

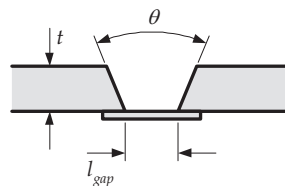

Note

1. The above figures are shown for guidance only. Actual details and dimensions are to be in accordance with a recognised fabrication standard. See 4.1.2.1

5.2.2 Thickness difference in butt welds

- 5.2.2.1 Abrupt change of section is to be avoided where plates of different thicknesses are butt welded.
- 5.2.2.2 Where plates to be joined differ in thickness by more than 4mm, a suitable transition taper is to be provided. The transition may be formed by tapering the thicker member, or by specifying a weld joint design which provides the required transition.
- 5.2.2.3 For the transverse butts in longitudinal strength members, the transition taper length is to be not less than three times the offset.
- 5.2.2.4 Differences in thickness greater than 4mm and without transition taper may be accepted for specific applications.

5.3 Tee or Cross Joints

5.3.1 General

- 5.3.1.1 The connection of primary support members and stiffener web/end connections and joints formed by plating abutting on another plate panel is generally to be made by fillet welds sized in accordance with 5.7 and Fig. 6.5.2. Examples of other typical tee or cross joint weld arrangements are shown in Fig. 6.5.3.
- 5.3.1.2 Where the connection is highly stressed or otherwise considered critical, a partial or full penetration weld is to be achieved by bevelling the edge of the abutting plate. See 5.3.4 and Fig. 6.5.3.

Fig. 6.5.2 Typical Tee or Cross Joint Fillet Welds

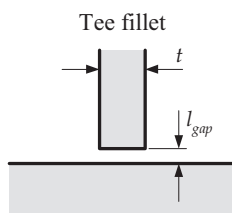

Note

1. The above figure is shown for guidance only. Actual details and dimensions are to be in accordance with a recognised fabrication standard. See 4.1.2.1.

Fig. 6.5.3 Other Typical Tee and Cross Joint Welds

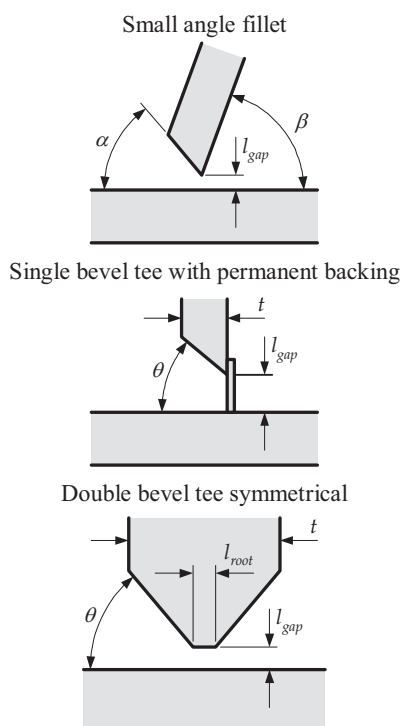

Note

1. The above figures are shown for guidance only. Actual details and dimensions are to be in accordance with a recognised fabrication standard. See 4.1.2.1.

5.3.2 Continuous welding

5.3.2.1 Continuous welding is to be adopted in the following locations:

- (a) all fillet welds where higher strength steel is used
- (b) boundaries of weathertight decks and erections, including hatch coamings, companionways and other openings
- (c) boundaries of tanks and watertight compartments
- (d) all structures in ballast and fresh water tanks and the ballast and fresh water tank bulkhead stiffeners
- (e) all structures in the aft peak and the aft peak bulkhead stiffeners
- (f) all structures in the fore peak tank/void
- (g) all welding inside tanks intended for crude oil, petroleum products, chemicals, edible liquids or fresh water cargoes
- (h) welding in way of all end connections, including end brackets, lugs, scallops, and at the orthogonal connections with other members
- (i) all lap welds in the main hull
- (j) primary support members and stiffener members to bottom shell in the $0.3L_{CSR-T}$ forward region
- (k) flat bar longitudinals to plating

- (l) the attachment of minor fittings to higher strength steel plating and other connections or attachments.

5.3.3 Intermittent welding

5.3.3.1 Where continuous welding is not required, intermittent welding may be applied.

5.3.3.2 Where beams, stiffeners, frames, etc. are intermittently welded and pass through slotted girders, shelves or stringers, there is to be a pair of matched intermittent welds on each side of every intersection. In addition, the beams, stiffeners and frames are to be efficiently attached to the girders, shelves and stringers.

5.3.4 Full or partial penetration corner or tee joints

5.3.4.1 Where high tensile stresses act through an intermediate plate (see **Fig. 6.5.4**), increased fillet welds or penetration welds are to be used as required by **5.8**. Examples of such structures are:

- (a) connection of hopper to inner hull
- (b) longitudinal/transverse bulkhead primary support member end connections to the double bottom
- (c) connection of corrugated bulkhead lower stool side plates to shelf plate and inner bottom/hopper tank
- (d) connections of gusset plates to corrugated bulkheads
- (e) connection of double bottom floors, lower hopper tank webs and double bottom girders below corrugated bulkhead flanges and gusset plates for corrugated bulkheads configured without lower stools
- (f) structural elements in double bottoms below bulkhead primary support members and stool plates.

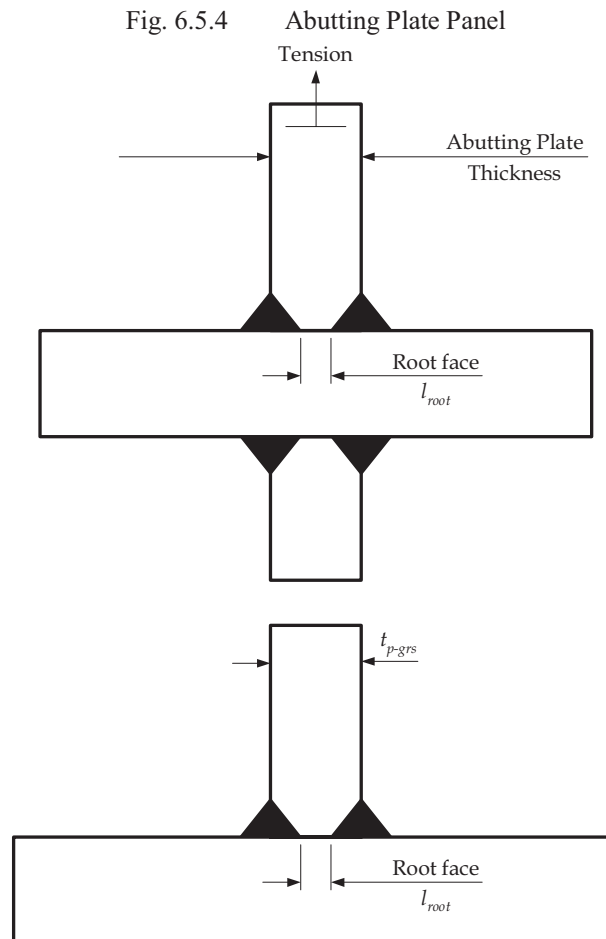

5.3.4.2 Full or partial penetration welds, with maximum root face, $l_{root} = t_{p-grs}/3$, where l_{root} is the weld root face length and t_{p-grs} is the gross plate thickness, as shown in **Fig. 6.5.4**, are to be used in the connection of hopper sloped plating to inner bottom.

5.3.4.3 Full penetration welds are to be used in the following connections:

- (a) lower end of vertical corrugated bulkhead connections
- (b) lower end of gusset plates fitted to corrugated bulkheads
- (c) rudder horns and shaft brackets to shell structure

- (d) rudder side plating to rudder stock connection areas
- (e) edge reinforcements within $0.6L_{CSR-T}$ amidships to the strength deck, sheer strake, bottom and bilge plating, when the transverse dimensions of the opening exceeds $300mm$, see **Fig. 6.5.5**. Where collar plates are fitted in way of pipe penetrations, the collar plate is to be welded by a continuous fillet weld.
- (f) abutting plate panels with gross plate thickness, t_{p-grs} , as shown in **Fig. 6.5.4**, less than or equal to $12mm$, forming outer shell boundaries below the scantling draught, T_{sc} , including, but not limited to; sea chests, rudder trunks, and portions of transoms. For gross plate thickness, t_{p-grs} , greater than $12mm$, partial penetration welding with a maximum root face length $l_{root} = t_{p-grs}/3$ is acceptable.
- (g) crane pedestals and associated bracketing and support structure, as required by **Section 11/3.1.4.14**.

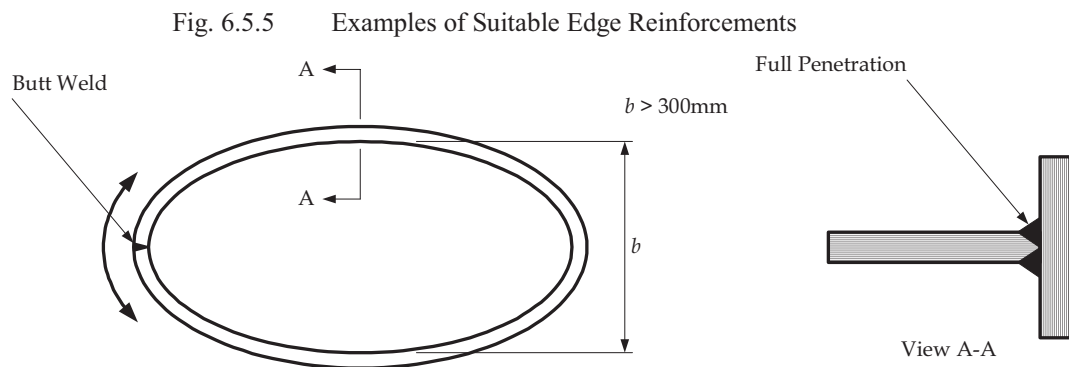

5.4 Lapped Joints

5.4.1 General

5.4.1.1 Overlaps may be adopted for end connections where the connection is not subject to high tensile or compressive loading.

5.4.1.2 Where overlaps are adopted, the width of the overlap, w_{lap} , is not to be less than three *times*, but not greater than four *times*, the gross thickness of the thinner of the plates being joined. See **Fig. 6.5.6**. Where the gross thickness of the thinner plate being joined has a thickness of $25mm$ or more the overlap will be subject to special consideration.

5.4.1.3 The overlaps for lugs and collars in way of cut-outs for the passage of stiffeners through webs and bulkhead plating are not to be less than three *times* the gross thickness of the lug but need not be greater than $50mm$. The joints are to be positioned to allow adequate access for completion of sound welds.

5.4.1.4 The faying surfaces of lap joints are to be in close contact and both edges of the overlap are to have continuous fillet welds.

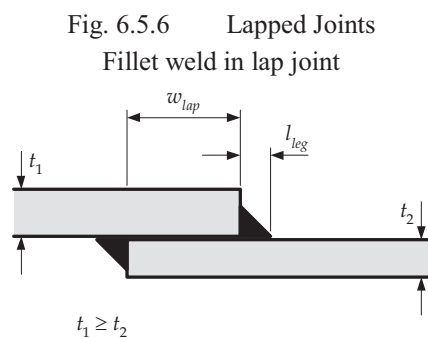

5.4.2 Overlapped end connections

5.4.2.1 Lapped end connections, where accepted by the Rules, are to have continuous welds on each edge with leg length, l_{leg} , as shown in **Fig. 6.5.6**, such that the sum of the two leg lengths is not less than 1.5 times the gross thickness of the thinner plate.

5.4.3 Overlapped seams

5.4.3.1 Overlapped seams are to have continuous welds on both edges, of the sizes required by **Table 6.5.1** for the boundaries of tank or watertight bulkheads. Seams for plates with a gross thickness of 12.5mm or less, which are clear of tanks, may have one edge with intermittent welds in accordance with **Table 6.5.1** for watertight bulkhead boundaries.

5.5 Slot Welds

5.5.1 General

5.5.1.1 Slot welds may be specially approved for particular applications. Typical applications are indicated in **5.5.2** and **5.5.3**, and typical arrangements are shown in **Fig. 6.5.7**.

5.5.1.2 Slots are to be well-rounded and have a minimum slot length, l_{slot} , of 75mm and width, w_{slot} , of twice the gross plate thickness. Where used in the body of doublers and similar locations, such welds are in general to be spaced a distance, s_{slot} , of $2l_{slot}$ to $3l_{slot}$ but not greater than 250mm .

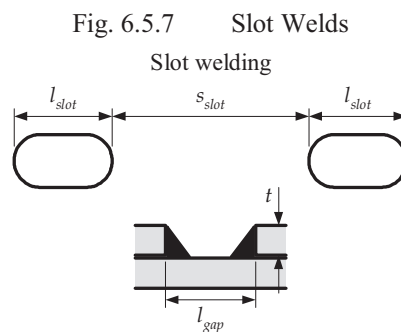

5.5.2 Closing plates

5.5.2.1 For the connection of plating to internal webs, where access for welding is not practicable, the closing plating may be attached by slot fillet welds to face plates fitted to the webs.

5.5.2.2 Slots are to be well rounded and have a minimum slot length, l_{slot} , of 90mm and a minimum width, w_{slot} , of twice the gross plate thickness. Slots cut in plating are to have smooth, clean and square edges and are in general to be spaced a distance, s_{slot} , not greater than 140mm . Slots are not to be filled with welding.

5.6 Stud Welds

5.6.1 General

5.6.1.1 Where permanent or temporary studs are to be attached by welding to main structural parts in areas subject to high stress, the proposed location of the studs is to be submitted for approval.

5.7 Determination of the Size of Welds

5.7.1 General

5.7.1.1 The following weld sizes are to be rounded to the nearest half millimetre.

5.7.1.2 The leg length, l_{leg} , as shown in **Fig. 6.5.8**, of continuous, lapped or intermittent fillet welds, in association with the requirements of **5.7.2** to **5.7.5**, is not to be taken as less than:

- (a) $l_{leg} = f_l t_{p-grs}$
- (b) $l_{leg} = f_{yd} f_{weld} f_2 t_{p-grs} + t_{gap}$
- (c) l_{leg} as given in **Table 6.5.2**

Where:

$$f_l = 0.30 \quad \text{for double continuous welding}$$

$$= 0.38 \quad \text{for intermittent welding}$$

t_{p-grs} : the gross plate thickness, in mm . Is generally to be taken as that of the abutting member (member being attached). See **5.7.1.5**

- f_{yd} : correction factor taking into account the yield strength of the weld deposit

$$= \left(\frac{1}{k}\right)^{0.5} \left(\frac{235}{\sigma_{weld}}\right)^{0.75}$$
 but is not to be taken as less than 0.707
- σ_{weld} : minimum yield stress of the weld deposit, and is not to be less than
 305N/mm² for welding of normal strength steel
 375N/mm² for welding of higher strength steels with yield strength of 265 to 355N/mm²
 400N/mm² for welding of higher strength steel with yield strength of 390N/mm²
 See 5.9.4 for additional requirements that are to be applied where the weld size is determined based on a weld deposit yield strength that exceeds the specified minimum value
- k : higher strength steel factor, as defined in 1.1.4. k is to be based on the material of the abutting member
- f_{weld} : weld factor depending on the type of structural member, see 5.7.2, 5.7.3 and 5.7.5
- f_2 : correction factor for the type of weld
 1.0 for double continuous fillet

$$\frac{s_{ctr}}{l_{weld}}$$
 for intermittent or chain welding
- l_{weld} : the actual length of weld fillet, clear of crater, in mm
- s_{ctr} : the distance between successive weld fillets, from centre to centre, in mm
- t_{gap} : allowance for weld gap (lesser gaps may be permitted, see 5.9.2)
 $= 2.0mm$ for $t_{p-grs} > 6.5mm$

$$= 2 \left(1.25 - \frac{1}{f_2} \right) (mm)$$
 for $t_{p-grs} \leq 6.5mm$

5.7.1.3 The throat size is not to be less than $l_{leg}/\sqrt{2}$, where the leg length, l_{leg} , is as shown in Fig. 6.5.8.

5.7.1.4 The leg size for matched fillet welds either side of an intersection with intermittent welding is not to be greater than $0.62t_{p-grs}$ or $6.5mm$, whichever is the lesser.

5.7.1.5 Where the gross web thickness of the abutting longitudinal stiffener is greater than $15mm$ and exceeds the thickness of the table member (e.g. plating), the welding is to be double continuous and the leg length of the weld is to be not less than the greatest of the following:

- 0.3 times the gross thickness of the table member. The table member thickness used need not be greater than $30mm$
- 0.27 times the gross thickness of the abutting member plus $1.0mm$. The leg size need not be greater than $8.0mm$
- as given by Table 6.5.2 for stiffeners to plating.

5.7.1.6 Where the gap between members being joined exceeds $2mm$ and is not greater than $5mm$, the weld leg size is to be increased by the amount of the opening in excess of $2mm$. Where the opening between members is greater than $5mm$, corrective measures are to be taken, in accordance with an approved welding procedure specification.

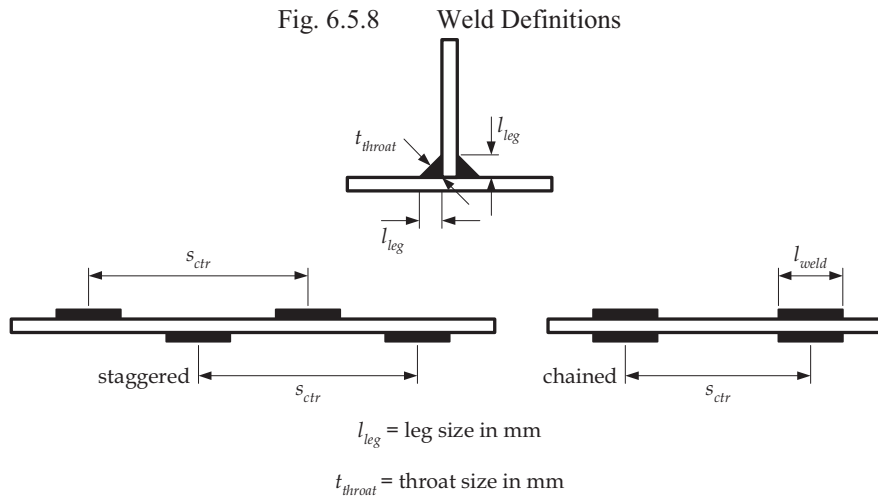

5.7.2 Welding of fillet joints of main structural components

5.7.2.1 General weld factors for the connections of the structural components of the hull are given in **Table 6.5.1**.

5.7.2.2 Where components of the hull form a part of a double skin primary support member the requirements of **5.7.4** are also to be applied.

5.7.2.3 Where high tensile stresses act through an intermediate plate (see **Fig. 6.5.4**), increased fillet welds or penetration welds are to be used as required by **5.8**.

5.7.3 Welding of primary support members

5.7.3.1 Weld factors for the connections of the web plating of primary support members are given in **Table 6.5.4**.

5.7.3.2 Where the minimum weld size is determined by the requirements of **5.7.1.2(b)** the weld connections to shell, decks or bulkheads are to take account of the material lost in the cut out where stiffeners pass through the member. In cases where the web plating and the width of the notch exceeds 15 percent of the stiffener spacing, the size of the weld leg length is to be multiplied by:

$$\frac{0.85s}{l_w}$$

Where:

s : stiffener spacing, in *mm*

l_w : length of web plating between notches, in *mm*, see **Fig. 6.5.9**

Fig. 6.5.9 Lost Material in Web Cut-outs for Stiffeners

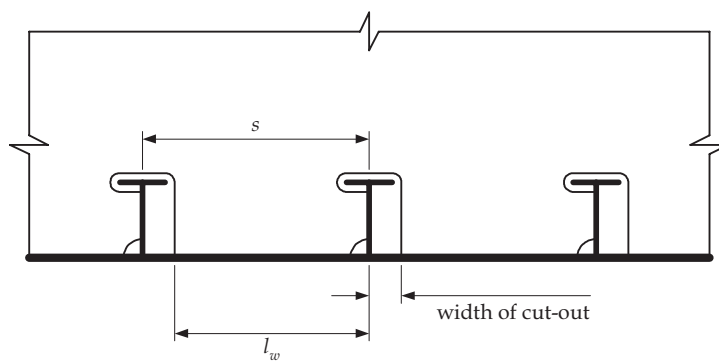

5.7.4 Welding of end connections of primary support members

5.7.4.1 Welding of end connections of primary support members (i.e. transverse frames and girders) is to be such that the weld area, A_{weld} , is to be equivalent to the Rule gross cross-sectional area of the member. In terms of weld leg length, l_{leg} , this is to be taken as by:

$$l_{leg} = 1.41 f_{yd} \frac{h_w t_{p-grs}}{l_{dep}} \quad (mm)$$

Where:

- h_w : web height of primary support member, in *mm*, see **Fig. 6.5.10**
 t_{p-grs} : rule gross thickness of the primary support member, in *mm*
 l_{dep} : total length of deposit of weld metal, in *mm*. Generally this can be taken as twice l_{weld} shown in **Fig. 6.5.10** for a double continuous fillet weld
 f_{yd} : correction factor taking into account the yield strength of the weld deposit, as defined in **5.7.1.2**

In no case is the size of weld to be less than that calculated in accordance with **5.7.1.2**, using a minimum weld factor, f_{welds} , of 0.48 in tanks or 0.38 elsewhere.

Fig. 6.5.10 End Connection of Primary Support Members

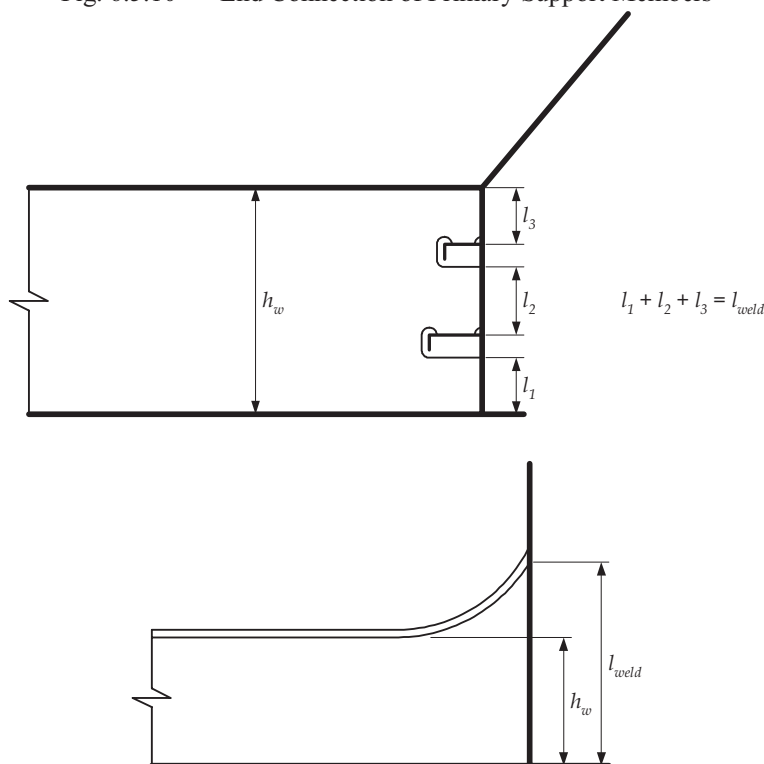

Note

1. The length l_{weld} is the length of the welded connection. The total length of the weld deposit l_{dep} is, for double continuous fillet welds, twice the length of the welded connection l_{weld}

5.7.5 Welding at the ends of stiffeners

5.7.5.1 Welding of longitudinals to plating is to be double continuous at the ends of the longitudinals. In way of transverse the length of the double continuous weld is to be equal the depth of the longitudinal, or the depth of the end bracket, whichever is greater.

5.7.5.2 For deck longitudinals, a matched pair of welds is required at the intersection of longitudinals with transverse.

5.7.5.3 The welding of stiffener (i.e. longitudinals, beams and bulkhead stiffeners) end connections is to be not less than as required by **Table 6.5.5**. Where two requirements are given, the greater is to be complied with. The area of weld, A_{weld} , indicated in **Table 6.5.5**, is to be applied to each arm of the bracket or lapped connection.

5.7.5.4 Where a longitudinal strength member is cut at a primary support structure and the continuity of strength is provided by brackets, the weld area, A_{weld} , based on the effective throat *times* the length of the weld, is to be not less than the gross cross-sectional area of the member. If the longitudinal strength member is of high strength steel, the weld area, A_{weld} , is to be multiplied by f_{yd} , the correction factor taking into account the yield strength of the weld deposit as defined in **5.7.1.2**.

5.7.5.5 Where the stiffener member passes through, and is supported by the web of a primary support member, the weld connection is to be in accordance with the requirements of **Section 4/3.4.3.11**.

5.7.5.6 Where intermittent welding is permitted, unbracketed stiffeners of shell, watertight and oil-tight bulkheads, and house fronts are to have double continuous welds for one-tenth of their length at each end. Unbracketed stiffeners of non-tight structural bulkheads, deck house sides and aft ends are to have a pair of matched intermittent welds at each end.

5.8 Weld for Structures Subject to High Tensile Stresses

5.8.1 Minimum leg size

5.8.1.1 Where high tensile stresses act through an intermediate plate, see Fig. 6.5.11, the minimum leg length, l_{leg} , of double continuous welds is to be taken as:

$$l_{leg} = 1.92 \left(\frac{235}{\sigma_{weld}} \right)^{0.75} \left[0.2 + \left(\frac{\sigma}{270} - 0.25 \right) \frac{l_{root}}{t_{p-grs}} \right] t_{p-grs} + 2.0 \quad (mm)$$

Where:

σ : maximum tensile stress in plate being attached, in N/mm^2

l_{root} : root face length, in mm

t_{p-grs} : gross thickness of plate being attached, in mm

σ_{weld} : as defined in 5.7.1.2, where σ_{weld} is limited to the maximum value permitted by the limits imposed on correction factor taking into account the yield strength of the weld deposit, f_{yd} , as defined in 5.7.1.2

Fig. 6.5.11 Welds Subject To High Tensile Stresses

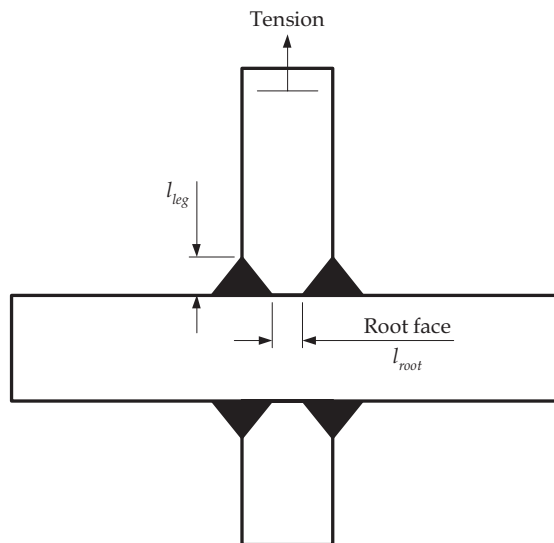

5.9 Reduced Weld Size

5.9.1 General

5.9.1.1 Reduction in fillet weld sizes that are required by 5.7 may be specially approved in accordance with either 5.9.2, 5.9.3 or 5.9.4.

5.9.1.2 Where any of the methods for reduction of the weld size are adopted, the specific requirements giving justification for the reduction are to be indicated on the drawings. The drawings are to document the weld design and dimensioning requirements for the reduced weld leg length and the required weld leg length given by 5.7 without the permitted leg length reduction. Also, notes are to be added to the drawings to describe the difference in the two leg lengths and the requirements for their application.

5.9.2 Controlled gaps

5.9.2.1 Where quality control facilitates working to a gap between members of $1mm$ or less, a reduction in fillet weld leg size of $0.5mm$ is permitted.

5.9.3 Deep penetration welding

5.9.3.1 Where an approved automatic deep penetration procedure is used and quality control facilities are working to a gap between members of 1mm or less, the weld factors given in **Tables 6.5.1, 6.5.2(c) and (d), 6.5.4 and 6.5.5** may be reduced by 15 percent. Reductions of up to 20 percent, but not more than the fillet weld leg size of 1.5mm, will be accepted provided that the Shipyard is able to consistently meet the following requirements:

- (a) the welding is performed to a suitable process selection confirmed by welding procedure tests covering both minimum and maximum root gaps
- (b) the penetration at the root is at least the same amount as the reduction into the members being attached
- (c) demonstrate that an established quality control system is in place.

5.9.4 Controlled welding consumables

5.9.4.1 Where quality control systems are in place which ensure that the grade of welding consumable used is higher than the minimum required for the particular strength steel being welded, the welding consumables that are used may have a weld deposit material yield strength that is greater than the minimums specified in **5.7.1.2** and the size of the weld may be determined based on the yield strength of the higher grade welding consumable.

5.10 End Connections of Pillars and Cross Ties**5.10.1 Effective weld area**

5.10.1.1 The end connections of pillars and cross ties are to have an effective fillet weld area (weld throat multiplied by weld length) not less than:

$$A_{weld} = f_3 \left(\frac{235}{\sigma_{weld}} \right)^{0.75} A_{grs} P \quad (cm^2)$$

Where:

- A_{grs} : gross cross-sectional area, for the pillar or cross tie, in m^2
 P : design pressure load, for the structure under consideration, in kN/m^2
 σ_{weld} : minimum yield stress of the deposit, as given in **5.7.1.2**, where σ_{weld} is limited to the maximum value permitted by the limits imposed on f_{yd} in **5.7.1.2**
 f_3 = 0.05 when pillar or cross tie is in compression only
= 0.14 when pillar or cross tie is in tension

5.11 Alternatives**5.11.1 General**

5.11.1.1 The foregoing are considered minimum requirements for electric-arc welding in hull construction, but alternative methods, arrangements and details will be specially considered for approval.

5.11.1.2 The leg length limits given in **Table 6.5.2** are to be complied with in all cases.

Table 6.5.1 Weld Factors

Items	Weld Factor	Remarks
	f_{weld}	
(1) General application		except as required by items 2-11
Watertight boundaries	0.43	
Non-tight plate boundaries	0.18	
Strength deck plating to shell	see Table 6.5.3	
Other decks to shell and bulkheads (except where forming tank boundaries)	0.30	generally continuous
Stiffeners to plating (clear of end connections)	0.13	in dry spaces
	0.18	in tanks
Stiffeners to plating for 0.1 span at ends	0.21	or extent of end bracket if greater
Panel stiffeners	0.13	
Overlapped welds generally	0.36	
Longitudinals, with gross web thickness greater than 15mm, to plating	see 5.7.1.5	t_{p-grs} as defined in 5.7.1.5
(2) Bottom construction in cargo tank region		(1)
Non-tight centre girder: to keel	0.30	
to inner bottom	0.28	no scallops
Non-tight boundaries of floors and girders	0.15	mid half span
	0.24	end quarters span
Floors and girder to inner bottom in way of:		
vertical primary supporting members	0.43	(1)
Connection between floors and girders	0.36	(1)
End connection of floors and girders	0.43	(1)
Docking brackets	0.30	
(3) Side construction in cargo tank region		including bilge hopper tanks, ⁽¹⁾
Vertical webs to inner hull bulkhead in way of deck transverse/bracket	0.43	
in way of cross tie, as applicable	0.36	
Elsewhere	0.24	
Vertical webs to shell	0.24	
Vertical webs end connection	0.43	(1)
(4) Cargo tank bulkhead construction		including pump room and cofferdam, ⁽¹⁾
Longitudinal and transverse oil-tight bulkhead boundaries:		
to deck, inner bottom and bottom shell	0.51	
at sides	0.43	
Vertical corrugation		
at upper end	0.51	
at lower end	see 5.3.4	
Non-tight bulkhead boundaries	0.24	
Primary support members	see Table 6.5.4	
Connection between primary support members	0.49	

Table 6.5.1 (Continued) Weld Factors

Items	Weld Factor	Remarks
	f_{weld}	
(5) Structures in machinery space		
Centre girder to keel and inner bottom	0.36	
Floors to centre girder in way of:		
Engines	0.36	
thrust and boiler bearers	0.36	
Floors to main engine foundation girders	0.36	
Floors/girders to shell and inner bottom	0.24	
Main engine foundation girders to top plate and primary hull structure	Partial penetration	edge to be prepared with maximum root $0.33t_{p-grs}$ deep penetration
Foundation:		
auxiliary diesels (>350kW)	0.40	
boiler and other auxiliaries	0.35	
Brackets supporting engine foundation	0.21	
(6) Construction in $0.25L_{CSR-T}$ forward		
In way of flat of bottom:		
floors to shell and inner bottom	0.18	
girders to shell and inner bottom	0.28	
Bottom longitudinals to shell:		
flat of bottom forward	0.30	
Elsewhere	0.18	
side shell stringers to shell	0.24	
Fore peak construction:		
internal structures	0.18	
(7) Aft peak construction		
Internal structure:		
below water line	0.30	
above waterline	0.18	
(8) Superstructures and deck houses		
Connection of external bulkhead to deck		
first and second tier erections	0.28	
Elsewhere	0.15	
Internal bulkheads	0.12	

Table 6.5.1 (Continued) Weld Factors

Items	Weld Factor	Remarks
	f_{weld}	
(9) Closing Arrangements		
Hatch coaming to deck	0.43	
Cleats and fittings	0.60	minimum weld factor. Where $t_{p-grs} > 11.5mm$, l_{leg} need not exceed $0.62t_{p-grs}$. Penetration welding may be required depending on design
Hatch covers:		
oil-tight joints	0.46	
watertight joints:		
Outside	0.46	
Inside	0.18	
Hatch covers:		
at end of stiffener (unbracketed)	0.38	(2)
at end of stiffener (bracketed)	0.38	
Elsewhere	0.12	
(10) Deck Equipment		(3)
Masts, derrick posts, crane pedestals, etc., to deck	0.43	
Deck machinery seats to deck	0.20	
Mooring equipment seats	0.43	
(11) Miscellaneous fittings and equipment		
Rings for access hole type covers to ship	0.43	
Frames of shell and weathertight doors	0.43	
Stiffening of shell and weathertight doors	0.24	
Ventilators, air pipes, etc., coaming to deck	0.43	
Ventilators, etc., fittings	0.24	
Scuppers and discharge to deck	0.55	
Bulwark stays to deck	0.24	
Bulwark attachment to deck	0.43	
Guard rails, stanchions, etc., to deck	0.43	
Bilge keel ground bars to shell	see Table 11.3.1	
Bilge keels to ground bars	see Table 11.3.1	
Fabricated anchors	full penetration	

Notes

1. The weld size is to be increased for areas with high tensile stress, see 5.8.
2. Unbracketed stiffeners and webs of hatch covers are to be welded continuously to the plating and to the face plate for a length, at the ends, equal to the end depth of the member.
3. Weld factors are minimum values.

Table 6.5.2 Leg Size

Item	Minimum Leg Size ⁽¹⁾ , mm
(a) Gross plate thickness $t_{p-grs} \leq 6.5mm$ ⁽⁵⁾	
Hand or automatic welding	4.0
Automatic deep penetration welding	4.0
(b) Gross plate thickness $t_{p-grs} > 6.5mm$ ⁽⁵⁾	
Hand or automatic welding	4.5
Automatic deep penetration welding	4.0
(c) Welds within 3m below top of ballast and cargo tanks ⁽²⁾⁽⁴⁾	6.5
(d) All welds in cargo tank region, except in (c) ⁽⁴⁾	6.0

Notes

1. In all cases, the limiting value is to be taken as the greatest of the applicable values given above.
2. Only applicable to cargo and ballast tanks with weather deck as the tank top.
3. See 5.9 for provisions to reduce minimum leg size.
4. A reduction to 5.5mm leg size for the secondary structural elements such as carling, buckling stiffeners and tripping brackets may be applied without additional gap control.
5. For superstructure and deck houses, the minimum leg length may be taken as 3.5mm.

Table 6.5.3 Weld Connection of Strength Deck Plating to Sheer Strake

Stringer gross plate thickness, in mm	Weld type
$t_{p-grs} < 15$	Double continuous fillet weld with a leg size of $0.60 t_{p-grs} + 2.0mm$
$15 < t_{p-grs} < 20$	Single vee preparation to provide included angle of 50° with root face length $l_{root} < t_{p-grs} / 3$ in conjunction with a continuous fillet weld with a weld factor of 0.35 or Double vee preparation to provide included angle of 50° with root face length $l_{root} < t_{p-grs} / 3$
$t_{p-grs} > 20$	Double vee preparation to provide included angle of 50° with root face length $l_{root} < t_{p-grs} / 3$, but not to be greater than 10mm

Where t_{p-grs} = gross thickness of stringer plate, in mm

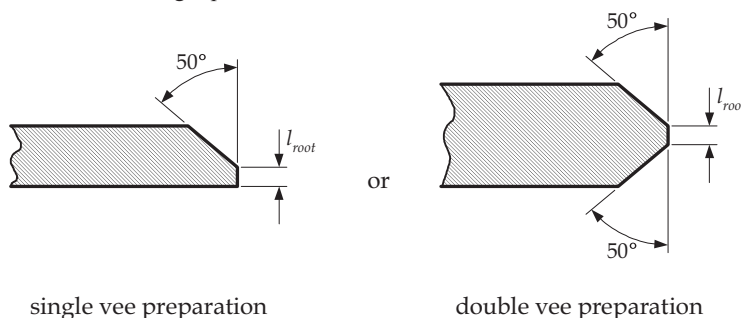

Note

Welding procedure, including joint preparation, is to be specified and approved for individual builders.

Where structural members pass through the boundary of a tank a leak stopper is to be arranged in accordance with 4.4.4. Alternative connections will be specially considered.

Table 6.5.4 Connection of Primary Support Members

Primary Support Member gross face area, in cm^2		Position ⁽¹⁾	Weld factor, f_{weld}			
Greater than	Not greater than		In tanks		In dry spaces	
			To face plate	To plating	To face plate	To plating
	30.0	At ends	0.20	0.26	0.20	0.20
		Remainder	0.12	0.20	0.12	0.15
30.0	65.0	At ends	0.20	0.38	0.20	0.20
		Remainder	0.12	0.26	0.12	0.15
65.0	95.0	At ends	0.42	0.59 ⁽³⁾	0.20	0.30
		Remainder	0.30 ⁽²⁾	0.42	0.15	0.20
95.0	130.0	At ends	0.42	0.59 ⁽³⁾	0.30	0.42
		Remainder	0.30 ⁽²⁾	0.42	0.20	0.30
130.0		At ends	0.59 ⁽³⁾	0.59 ⁽³⁾	0.42	0.59 ⁽³⁾
		Remainder	0.42	0.42	0.30	0.42

Notes

1. The weld factors 'at ends' are to be applied for 0.2 *times* the overall length of the member from each end, but at least beyond the toe of the member end brackets. On vertical webs, the increased welding may be omitted at the top, but is to extend at least 0.3 *times* overall length from the bottom.
2. Weld factor 0.38 to be used for cargo tanks.
3. Where the web plate thickness is increased locally to meet shear stress requirements, the weld size may be based on the gross web thickness clear of the increased area, but is to be not less than weld factor of 0.42 based on the increased gross thickness.
4. In regions of high stress, see 5.3.4, 5.7.4 and 5.8.

Table 6.5.5 Stiffener End Connection Welds

Connection	Weld area, A_{weld} , in cm^2	Weld Factor, f_{weld} ⁽¹⁾
(1) Stiffener welded direct to plating	$0.25A_{stf-grs}$ or $6.5 cm^2$ whichever is the greater	0.38
(2) Bracketless connection of stiffeners, stiffener lapped to bracket or bracket lapped to stiffener:		
(a) in dry space	$1.2 \sqrt{Z_{grs}}$	0.26
(b) in tank	$1.4 \sqrt{Z_{grs}}$	0.38
(c) main frame to tank side bracket in $0.15L_{CSR-T}$ forward	as (a) or (b)	0.38
(3) Bracket welded to face of stiffener and bracket connection to plating	—	0.38

Where:

- $A_{stf-grs}$ gross cross sectional area of the stiffener, in cm^2
 A_{weld} weld area, in cm^2 , and is calculated as total length of weld, in cm , *times* throat thickness, in cm
 (Where the gap exceeds 2mm the weld size is to be increased. See 5.7.1.6)
 Z_{grs} the gross section modulus required, in cm^3 , of the stiffener on which the scantlings of the bracket are based

Note

1. For minimum weld fillet sizes, see Table 6.5.2.

Section 7 LOADS

1. Introduction

1.1 General

1.1.1 Application

1.1.1.1 This section provides in detail the loads and load combinations for the scantling calculations. The loads cover load scenarios in harbour and at sea, see **Section 2/5.4**, dividing the loads into static load components, dynamic load components, sloshing loads and impact loads.

1.2 Definitions

1.2.1 Coordinate system

1.2.1.1 The applied coordinate system x, y, z is as defined in **Section 4/1.4.1.1**.

1.2.1.2 The direction of the incident waves are specified by the angle β between the x -axis and the propagating wave direction as shown in **Fig. 7.1.1**. Examples given:

- head sea is waves propagating in the negative x -direction,
- beam sea is waves propagating in the positive or negative y -direction,
- oblique sea is waves propagating in a direction between head and beam sea (or following and beam sea), and
- following sea is waves propagating in positive x -direction.

Fig. 7.1.1 Definition of Wave Heading

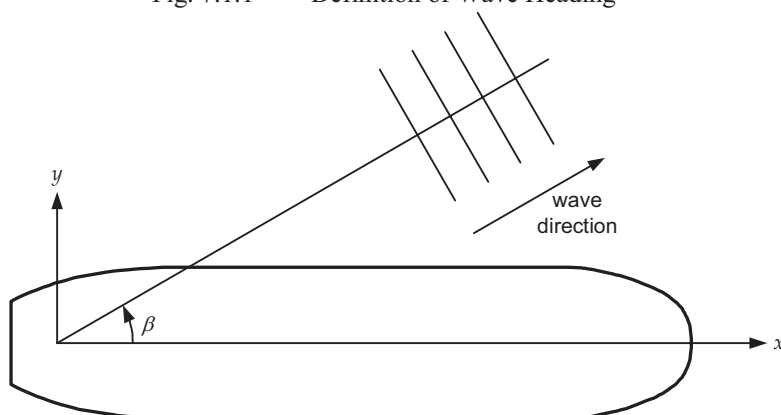

1.2.2 Sign conventions

1.2.2.1 Positive motions, as shown in **Fig. 7.1.2**, are defined as:

- positive surge is translation along positive x -axis (forward)
- positive sway is translation along positive y -axis (towards port side of vessel)
- positive heave is translation along positive z -axis (upwards)
- positive roll is starboard down and port side up
- positive pitch is bow down and stern up
- positive yaw is bow rotating towards portside of vessel and stern towards starboard side.

Fig. 7.1.2 Definition of Positive Motions

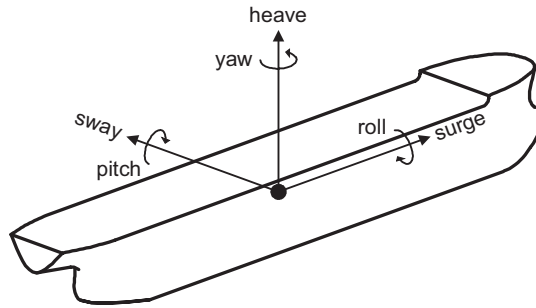

Note

1. This figure shows the rotation axis and not the coordinate system.

1.2.2.2 Positive accelerations are defined as:

- (a) positive longitudinal acceleration is acceleration along positive x -axis (forward)
- (b) positive transverse acceleration is acceleration along positive y -axis (towards portside of vessel)
- (c) positive vertical acceleration is acceleration along positive z -axis (upwards).

1.2.2.3 The sign convention of positive vertical hull girder shear force is shown in **Fig. 7.1.3**.

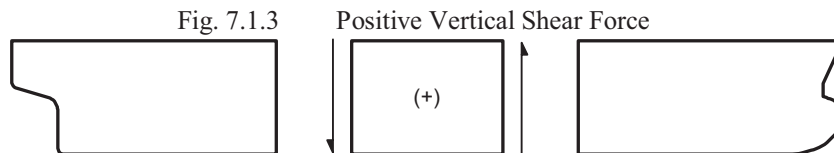

1.2.2.4 The sign conventions of positive hull girder bending moments are shown in **Fig. 7.1.4** and **7.1.5**, and are defined as:

- (a) positive vertical bending moment is a hogging moment and negative vertical bending moment is a sagging moment
- (b) positive horizontal bending moment is tension on the starboard side and compression on the port side.

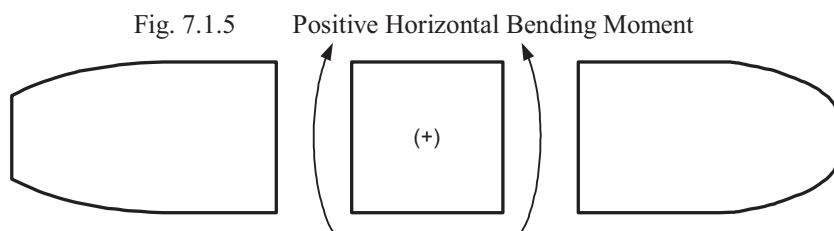
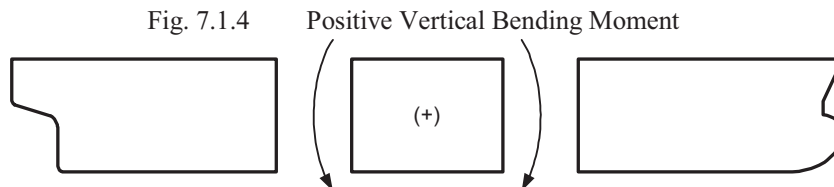

2. Static Load Components

2.1 Static Hull Girder Loads

2.1.1 Permissible hull girder still water bending moment

2.1.1.1 The designer is to provide the permissible hull girder hogging and sagging still water bending moment limits for seagoing, $M_{sw-perm-sea}$, and harbour/sheltered water operations, $M_{sw-perm-harb}$.

2.1.1.2 The permissible hull girder hogging and sagging still water bending moment limits are to be given at each transverse bulkhead in the cargo area, at the middle of cargo tanks, at the collision bulkhead, at the engine room forward bulkhead and at the midpoint between the fwd and aft engine room bulkhead.

2.1.1.3 The permissible hull girder hogging and sagging still water bending moment envelope is given by linear interpolation between values at the longitudinal positions given in **2.1.1.2**.

2.1.1.4 The permissible hull girder hogging and sagging still water bending moment envelopes are to be included in the loading manual as required in **Section 8/1.1.2**.

2.1.1.5 The permissible hull girder hogging and sagging still water bending moment envelopes for seagoing operations, $M_{sw-perm-sea}$, are to envelop the minimum hull girder hogging and sagging still water bending moments given in **2.1.2.1** and **2.1.2.2** the most severe hogging and sagging hull girder still water bending moments calculated for any seagoing loading condition given in the loading manual. The requirements for the loading conditions are given in **Section 8/1.1.2**.

2.1.1.6 The permissible hull girder hogging and sagging still water bending moment envelopes for harbour/sheltered water operation, $M_{sw-perm-harb}$, are to envelop the minimum hull girder hogging and sagging still water bending moments given in **2.1.2.3** and the most severe hogging and sagging hull girder still water bending moments calculated for any harbour/sheltered water loading condition given in the loading manual and are not to be less than the permissible envelopes for seagoing operation, $M_{sw-perm-sea}$.

Guidance note:

It is recommended that, for initial design, the permissible hull girder hogging and sagging still water bending moment envelopes are at least 5% above the hull girder still water bending moment envelope from the loading conditions in the loading manual, to account for growth and design margins during the design and construction phase of the ship.

2.1.2 Minimum hull girder still water bending moment

2.1.2.1 The minimum hull girder hogging and sagging still water bending moment for seagoing operations, $M_{sw-min-sea-mid}$, at amidships is to be taken as:

for hogging:

$$M_{sw-min-sea-mid} = f_{sea} (Z_{v-min} \sigma_{perm-sea} 10^3 - M_{wv-hog}) \quad (kNm)$$

which is identical to

$$M_{sw-min-sea-mid} = 0.01 C_{wv} L_{CSR-T}^2 B (11.97 - 1.9C_b) \quad (kNm)$$

for sagging:

$$M_{sw-min-sea-mid} = f_{sea} (Z_{v-min} \sigma_{perm-sea} 10^3 + M_{wv-sag}) \quad (kNm)$$

which is identical to

$$M_{sw-min-sea-mid} = -0.05185 C_{wv} L_{CSR-T}^2 B (C_b + 0.7) \quad (kNm)$$

Where:

f_{sea} -0.85 for sagging

1.0 for hogging

Z_{v-min} : rule minimum hull girder section modulus as given in **Section 8/1.2.2.2**, in m^3

$\sigma_{perm-sea}$: allowable seagoing hull girder bending stress at midships, as defined in **Section 8/1.2.3.2**, in N/mm^2

- M_{wv-hog} : envelope values of hogging vertical wave bending moment at midships as defined in 3.4.1.1, in kNm
- M_{wv-sag} : envelope values of sagging vertical wave bending moment at midships as defined in 3.4.1.1, in kNm
- C_{wv} : wave coefficient, as defined in 3.4.1.1
- L_{CSR-T} : rule length, , in m , as defined in Section 4/1.1.1.1
- B : moulded breadth, in m , as defined in Section 4/1.1.3.1, in m
- C_b : block coefficient, as defined in Section 4/1.1.9.1

2.1.2.2 The minimum hull girder hogging and sagging still water bending moment for seagoing operations, $M_{sw-min-sea}$, at any longitudinal position is to be taken as:

$$M_{sw-min-sea} = f_{sw} M_{sw-min-sea-mid} \quad (kNm)$$

Where:

- f_{sw} 1.0 within $0.4L_{CSR-T}$ amidships
- 0.15 at $0.1L_{CSR-T}$ from A.P. or F.P.
- 0 at A.P. and F.P.

intermediate f_{sw} values are to be obtained by linear interpolation, see Fig. 7.2.1

2.1.2.3 The minimum hull girder hogging and sagging still water bending moment for harbour/sheltered water operations, $M_{sw-min-harb}$, at any longitudinal position is to be taken as:

$$M_{sw-min-harb} = 1.25 M_{sw-min-sea} \quad (kNm)$$

Where:

- $M_{sw-min-sea}$: corresponding minimum hull girder hogging and sagging still water bending moment for seagoing operation at the section under consideration, see 2.1.2.1 and 2.1.2.2

Fig. 7.2.1 Still Water Bending Moment Distribution

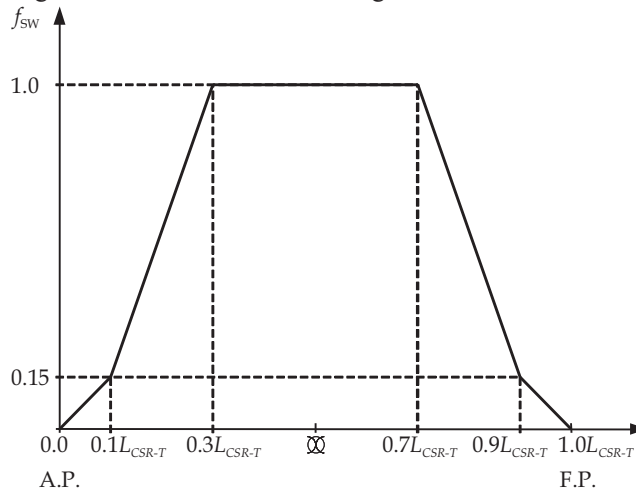

2.1.3 Still water shear force

2.1.3.1 The designer is to provide the permissible hull girder positive and negative still water shear force limits for seagoing, $Q_{sw-perm-seas}$ and harbour/sheltered water operations, $Q_{sw-perm-harb}$.

2.1.3.2 The permissible hull girder positive and negative still water shear force limits are to be given at each transverse bulkhead in the cargo area, at the middle of cargo tanks, at the collision bulkhead and at the engine room forward bulkhead.

2.1.3.3 The permissible hull girder positive and negative still water shear force envelope is given by linear interpolation between values at the longitudinal positions given in 2.1.3.2.

2.1.3.4 The permissible hull girder positive and negative still water shear force envelopes are to be included in the loading manual as required in Section 8/1.1.2.

2.1.3.5 The permissible hull girder positive and negative still water shear force envelopes for seagoing operation, $Q_{sw-perm-sea}$, are to envelope the minimum hull girder positive and negative still water shear forces given in **2.1.4.1**, **2.1.4.2** and the most severe positive and negative hull girder still water shear forces for any seagoing loading condition given in the loading manual. The requirements for the loading conditions are given in **Section 8/1.1.2**.

2.1.3.6 The permissible hull girder positive and negative still water shear force envelopes for harbour operation, $Q_{sw-perm-harb}$, are to envelope the minimum hull girder positive and negative still water shear forces given in **2.1.4.3**, **2.1.4.4** and the most severe positive and negative hull girder still water shear forces for any harbour/sheltered water loading condition given in the loading manual and are not to be less than the permissible envelopes for seagoing operation, $Q_{sw-perm-sea}$.

Guidance note:

It is recommended that, for initial design, the permissible hull girder still water shear force envelopes are at least 10% above the hull girder shear force envelope from the loading conditions in the loading manual, to account for growth and design margins during the design and construction phase of the ship.

2.1.4 Minimum hull girder still water shear force

2.1.4.1 For ships with two longitudinal bulkheads, the minimum hull girder positive and negative still water shear force for seagoing operation, $Q_{sw-min-sea}$, in way of transverse bulkheads between centre cargo tanks, is to be taken as:

$$Q_{sw-min-sea} = \pm \max \left\{ \begin{array}{l} 0.225 \rho g B_{local} l_{tk} T_{sc} \\ 0.5 \rho g [0.98 (V_{CT} + 2V_{ST}) - 0.7 B_{local} l_{tk} T_{sc}] \end{array} \right\} \quad (kN)$$

and taken as the maximum value of $Q_{sw-min-sea}$ calculated for cargo/ballast tanks forward and aft of the transverse bulkhead

Where:

- ρ : density of cargo/sea water, not to be taken less than 1.025 tonnes/m³
- g : acceleration due to gravity, 9.81 m/s²
- B_{local} : local breadth at T_{sc} at the middle length of the tank under consideration, in m
- l_{tk} : length of cargo tank under consideration, taken at the forward or aft side of the transverse bulkhead under consideration, in m
- T_{sc} : scantling draught, in m , as defined in **Section 4/1.1.5.5**
- V_{CT} : volume of centre cargo tank, taken for the cargo tank on the forward or aft side of the transverse bulkhead under consideration, in m^3
- V_{ST} : volume of side cargo tank, taken for the cargo tank on the forward or aft side of the transverse bulkhead under consideration, in m^3

2.1.4.2 For ships with centreline longitudinal bulkhead, the minimum hull girder positive and negative still water shear force for seagoing operation, $Q_{sw-min-sea}$, in way of transverse bulkheads between cargo tanks is to be taken as:

$$Q_{sw-min-sea} = \pm 0.4 \rho g B_{local} l_{tk} T_{sc} \quad (kN)$$

and taken as the maximum value of $Q_{sw-min-sea}$ calculated for cargo/ballast tanks forward and aft of the transverse bulkhead

Where:

- ρ : density of cargo/sea water, not to be taken less than 1.025 tonnes/m³
- g : acceleration due to gravity, 9.81 m/s²
- B_{local} : local breadth at T_{sc} at the middle length of the tank under consideration, in m
- l_{tk} : length of cargo tank under consideration, taken at the forward or aft side of the transverse bulkhead under consideration, in m
- T_{sc} : scantling draught, in m , as defined in **Section 4/1.1.5.5**

2.1.4.3 For ships with two longitudinal bulkheads, the minimum hull girder positive and negative still water shear force for harbour/sheltered water operation, $Q_{sw-min-harb}$, in way of transverse bulkheads between centre cargo tanks, is to be taken as:

$$Q_{sw-min-harb} = \pm \max \left\{ \begin{array}{l} 0.275 \rho g B_{local} l_{tk} T_{sc} \\ 0.5 \rho g [0.98 (V_{CT} + 2V_{ST}) - 0.6 B_{local} l_{tk} T_{sc}] \end{array} \right\} \quad (kN)$$

and taken as the maximum value of $Q_{sw-min-harb}$ calculated for cargo/ballast tanks forward and aft of the transverse bulkhead

Where:

ρ : density of cargo/sea water, not to be taken less than 1.025 tonnes/m³

g : acceleration due to gravity, 9.81 m/s²

B_{local} : local breadth at T_{sc} at the middle length of the tank under consideration, in m

l_{tk} : length of cargo tank under consideration, taken at the forward or aft side of the transverse bulkhead under consideration, in m

T_{sc} : scantling draught, in m , as defined in **Section 4/1.1.5.5**

V_{CT} : volume of centre cargo tank, taken for the cargo tank on the forward or aft side of the transverse bulkhead under consideration, in m^3

V_{ST} : volume of side cargo tank, taken for the cargo tank on the forward or aft side of the transverse bulkhead under consideration, in m^3

2.1.4.4 For ships with centreline longitudinal bulkhead, the minimum hull girder positive and negative still water shear force for harbour/sheltered water operation,

$Q_{sw-min-harb}$, in way of transverse bulkheads between cargo tanks, is to be taken as:

$$Q_{sw-min-harb} = \pm 0.45 \rho g B_{local} l_{tk} T_{sc} \quad (kN)$$

and taken as the maximum value of $Q_{sw-min-harb}$ calculated for cargo/ballast tanks forward and aft of the transverse bulkhead

Where:

ρ : density of cargo/sea water, not to be taken less than 1.025 tonnes/m³

g : acceleration due to gravity, 9.81 m/s²

B_{local} : local breadth at T_{sc} at the middle length of the tank under consideration, in m

l_{tk} : length of cargo tank under consideration, taken at the forward or aft side of the transverse bulkhead under consideration, in m

T_{sc} : scantling draught, in m , as defined in **Section 4/1.1.5.5**

2.2 Local Static Loads

2.2.1 General

2.2.1.1 The following static loads are considered:

- (a) static sea pressure
- (b) static tank pressure
- (c) tank overpressure
- (d) static deck load

2.2.2 Static sea pressure

2.2.2.1 The static sea pressure, P_{hys} , is to be taken as:

$$P_{hys} = \rho_{sw} g (T_{LC} - z) \quad (kN/m^2)$$

Where:

z : vertical coordinate of load point, in m , and is not to be greater than T_{LC} , see **Fig. 7.2.2**

ρ_{sw} : density of sea water, 1.025 tonnes/m³

T_{LC} : draught in the loading condition being considered, in m

g : acceleration due to gravity, 9.81 m/s²

Fig. 7.2.2 Static Sea Pressure

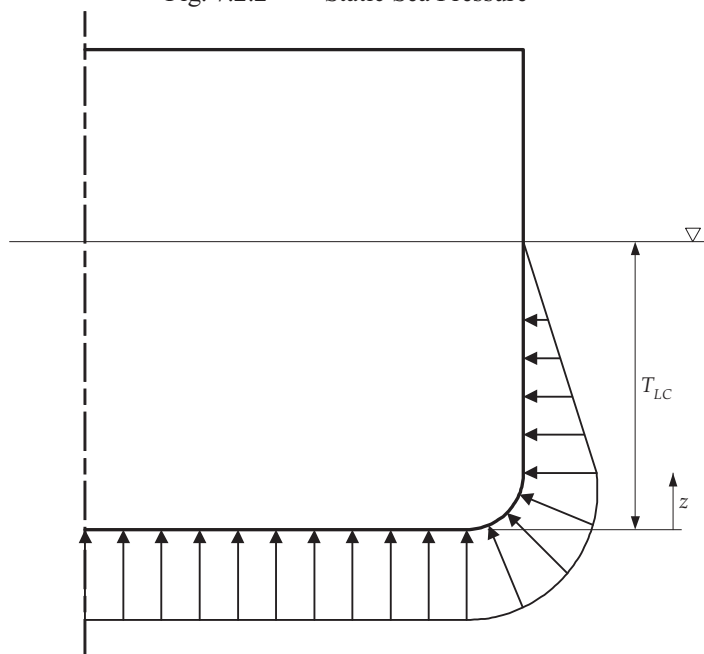

2.2.3 Static tank pressure

2.2.3.1 The static tank pressure, P_{in-tk} , is to be taken as:

$$P_{in-tk} = \rho g z_{tk} \quad (kN/m^2)$$

Where:

z_{tk} : vertical distance from highest point of tank, excluding small hatchways, to the load point, see **Fig. 7.2.3**, in m

ρ : density of liquid in the tank, is not to be taken as less than 0.9 for liquid cargo for fatigue strength 1.025 otherwise see **Section 2/3.1.8**, in $tonnes/m^3$

g : acceleration due to gravity, $9.81m/s^2$

2.2.3.2 The static tank pressure, P_{in-air} , in the case of overfilling or filling during flow through ballast water exchange, is to be taken as:

$$P_{in-air} = \rho_{sw} g z_{air} \quad (kN/m^2)$$

Where:

z_{air} : vertical distance from top of air pipe or overflow pipe to the load point, whichever is the lesser, see **Fig. 7.2.3**, in m

$$= z_{tk} + h_{air}$$

ρ_{sw} : density of sea water, $1.025tonnes/m^3$

g : acceleration due to gravity, $9.81m/s^2$

h_{air} : height of air pipe or overflow pipe, in m , is not to be taken less than $0.76 m$ above highest point of tank, excluding small hatchways. For tanks with tank top below the weather deck the height of air-pipe or overflow pipe is not to be taken less than $0.76m$ above deck at side unless a lesser height is approved by the flag Administration. See also **Fig. 7.2.3**.

Fig. 7.2.3 Pressure-Heads and Distances used for Calculation of Static Tank Pressure

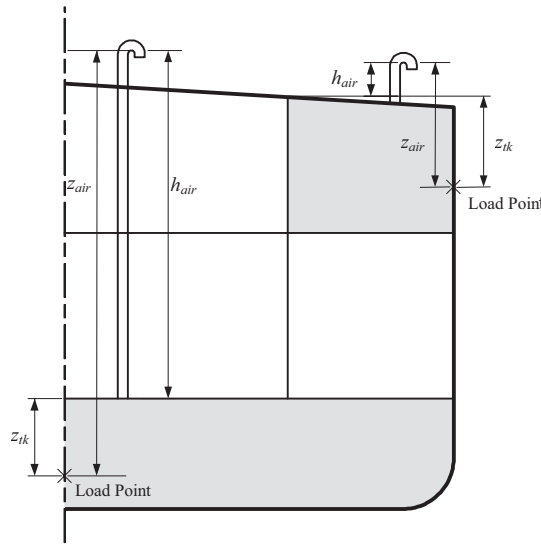

2.2.3.3 The added overpressure due to sustained liquid flow through air pipe or overflow pipe in the case of overfilling or filling during flow through ballast water exchange, P_{drop} , is to be taken as 25 kN/m^2 . Additional calculations may be required where piping arrangements may lead to a higher pressure drop, for example long pipes or arrangements such as bends and valves.

2.2.3.4 The pressure, $P_{in-flood}$, in compartments and tanks in a flooded or damaged condition is to be taken as:

$$P_{in-flood} = \rho_{sw} g z_{flood} \quad (\text{kN/m}^2)$$

Where:

z_{flood} : vertical distance from the load point to the deepest equilibrium waterline in damaged condition obtained from applicable damage stability calculations or to freeboard deck if the damage waterline is not given, in m

ρ_{sw} : density of sea water, 1.025 tonnes/m^3

g : acceleration due to gravity, 9.81 m/s^2

2.2.3.5 The tank testing pressure, $P_{in-test}$, is to be taken as the greater of the following, see also the testing requirements in **Table 11.5.1**:

$$P_{in-test} = \rho_{sw} g z_{test} \quad (\text{kN/m}^2)$$

$$P_{in-test} = \rho_{sw} g z_{tk} + P_{valve} \quad (\text{kN/m}^2)$$

Where:

z_{test} : vertical distance to the load point, is to be taken as the greater of the following, in m :

- (a) top of overflow
- (b) 2.4 m above top of tank

z_{tk} : vertical distance from highest point of tank, excluding small hatchways, to the load point, see **Fig. 7.2.3**, in m

ρ_{sw} : density of sea water, 1.025 tonnes/m^3

g : acceleration due to gravity, 9.81 m/s^2

P_{valve} : setting of pressure relief valve, if fitted, is not to be taken less than 25 kN/m^2

2.2.4 Static deck pressure from distributed loading

2.2.4.1 The pressure on decks and inner bottom, P_{stat} , is to be taken as:

$$P_{stat} = P_{deck} \quad (kN/m^2)$$

Where:

P_{deck} : uniformly distributed pressure on lower decks and decks within superstructures, including platform decks in the main engine room and for other spaces with heavy machinery components, in kN/m^2 . P_{deck} is not to be taken less than $16kN/m^2$.

Design pressures for decks of deck houses are provided in **Section 11/1.4**.

2.2.5 Static deck loads from heavy units

2.2.5.1 The scantlings of structure in way of heavy units of cargo and equipment are to consider gravity forces acting where the mass is 20 tonnes or greater. The load acting on supporting structures and securing systems for heavy units of cargo, equipment or structural components, F_{stat} , is to be taken as:

$$F_{stat} = m_{un}g \quad (kN)$$

Where:

m_{un} : mass of unit, in tonnes

g : acceleration due to gravity, $9.81m/s^2$

3. Dynamic Load Components

3.1 General

3.1.1 Basic components

3.1.1.1 Formulas for ship motions and accelerations are given in this sub-section.

3.1.1.2 Formulas for the envelope value of the basic dynamic load components are also given. The basic load components are:

- (a) vertical wave bending moment and shear force
- (b) horizontal wave bending moment
- (c) dynamic wave pressure
- (d) dynamic tank pressures.

3.1.2 Envelope load values

3.1.2.1 The envelope loads for scantling requirements and strength assessment are given at a 10^{-8} probability level, while the envelope loads for fatigue strength are given at a 10^{-4} probability level.

3.1.2.2 For scantling requirements and strength assessments, correction factors to account for non-linear effects and operational considerations in heavy weather are given.

3.1.2.3 For fatigue strength a factor adjusts the envelope load from a 10^{-8} probability level to a 10^{-4} probability level. A speed correction factor is applicable where appropriate.

3.1.2.4 The envelope value is the long term value, at a given probability level, taking into consideration the effect of all wave headings.

3.1.3 Metacentric height and roll radius of gyration

3.1.3.1 The metacentric height, GM , and roll radius of gyration, $r_{roll-gyr}$, associated with the rule loading conditions or specified draughts are specified in **Table 7.3.1**.

Table 7.3.1 GM and $r_{roll-gyr}$

	T_{LC}	GM	$r_{roll-gyr}$
Loaded at deep draught	between $0.9T_{sc}$ and T_{sc}	$0.12B$	$0.35B$
Loaded on reduced draught	$0.6T_{sc}$	$0.24B$	$0.40B$
In ballast	T_{bal}	$0.33B$	$0.45B$

Where:

- B : moulded breadth, in m , as defined in **Section 4/1.1.3.1**
- T_{LC} : draught in the loading condition being considered, in m
- T_{sc} : scantling draught, in m , as defined in **Section 4/1.1.5.5**
- T_{bal} : minimum design ballast draught, in m , as defined in **Section 4/1.1.5.2**
- T_{bal-n} : normal ballast draught, in m , as defined in **Section 4/1.1.5.3**

3.1.3.2 For the optional loading conditions, GM is to be taken as the corrected metacentric height given in the loading manual. Where GM for optional loaded or gale/emergency ballast conditions is not specified, GM is to be taken as $0.12B$ for mean draught greater or equal to $0.9T_{sc}$, and $0.24B$ for mean draught equal or less than $0.6T_{sc}$. For optional loading conditions with a mean draught other than the values defined, GM is to be obtained by linear interpolation based on values for $0.6T_{sc}$ and $0.9T_{sc}$.

3.1.3.3 $r_{roll-gyr}$ for optional loaded or gale/emergency ballast conditions is, unless provided based on the loading manual, to be taken as $0.35B$ for mean draught greater or equal to $0.9T_{sc}$, and $0.4B$ for mean draught equal or less than $0.6T_{sc}$. For optional loading conditions with a mean draught other than the values defined above, $r_{roll-gyr}$ may be obtained by linear interpolation based on values for $0.6T_{sc}$ and $0.9T_{sc}$.

3.1.3.4 For the loading conditions used for fatigue strength, GM is to be taken as the corrected metacentric height given in the loading manual. If not available, GM is to be taken as specified in **Table 7.3.1** for ballast condition and according to the procedure described in **3.1.3.2** for full load condition. $r_{roll-gyr}$ is, unless based on the loading

condition, to be taken as specified in **Table 7.3.1** for ballast condition and according to the procedure described in **3.1.3.3** for full load condition.

3.2 Motions

3.2.1 General

3.2.1.1 The envelope values for ship motions are given at a 10^{-8} probability level.

3.2.2 Roll motion

3.2.2.1 The natural roll period, U_{roll} , is to be taken as:

$$U_{roll} = \frac{2.30 r_{roll-gyr}}{\sqrt{GM}} \quad (secs)$$

Where:

GM : metacentric height, in m , as defined in **3.1.3**

$r_{roll-gyr}$: roll radius of gyration, in m , as defined in **3.1.3**

3.2.2.2 The roll angle, θ , is to be taken as:

$$\theta = \frac{50}{B + 75} (1.25 - 0.025 U_{roll}) f_{bk} \quad (rads)$$

Where:

f_{bk} 1.2 for ships without bilge keels

1.0 for ships with bilge keels

B : moulded breadth, in m , as defined in **Section 4/1.1.3.1**

U_{roll} : roll period, in $secs$, as defined in **3.2.2.1**

3.2.3 Pitch motion

3.2.3.1 The characteristic pitch period, U_{pitch} , is to be taken as:

$$U_{pitch} = f_V \sqrt{0.6 \frac{2\pi}{g} (1 + f_T) L_{CSR-T}} \quad (s)$$

Where:

$$f_V = 1.0 + \frac{V_0}{V} \left(\frac{L_{CSR-T}}{525} - 0.67 \right)$$

$$f_T = \frac{T_{LC}}{T_{sc}}$$

V_0 : vessel speed, in $knots$, is to be taken as:

0 for scantling requirements and strength assessment

$0.75V$ for fatigue strength

V : maximum service speed, in $knots$, as defined in **Section 4/1.1.8.1**

T_{sc} : scantling draught, in m , as defined in **Section 4/1.1.5.5**

T_{LC} : draught in the loading condition being considered, in m

L_{CSR-T} : rule length, in m , as defined in **Section 4/1.1.1.1**

3.2.3.2 The pitch angle, φ , is to be taken as:

$$\varphi = 960 \left(\frac{V_1}{C_b} \right)^{0.25} \frac{1}{L_{CSR-T}} \frac{\pi}{180} \quad (radians)$$

Where:

V_1 : vessel speed, in $knots$. Is to be taken as V , but not to be taken as less than 10

V : maximum service speed, in $knots$, as defined in **Section 4/1.1.8.1**

C_b : block coefficient, as defined in **Section 4/1.1.9.1**

L_{CSR-T} : rule length, in m , as defined in **Section 4/1.1.1.1**

3.3 Ship Accelerations

3.3.1 General

3.3.1.1 The envelope values for combined translatory accelerations due to motion in six *degrees* of freedom are given. The transverse and longitudinal components of acceleration include the component of gravity due to roll and pitch.

3.3.2 Common acceleration parameter

3.3.2.1 The common acceleration parameter, a_0 , is to be taken as:

$$a_0 = (1.58 - 0.47C_b) \left(\frac{2.4}{\sqrt{L_{CSR-T}}} + \frac{34}{L_{CSR-T}} - \frac{600}{L_{CSR-T}^2} \right)$$

Where:

C_b : block coefficient, as defined in **Section 4/1.1.9.1**

L_{CSR-T} : rule length, in m , as defined in **Section 4/1.1.1.1**

3.3.3 Vertical acceleration

3.3.3.1 The envelope vertical acceleration, a_v , at any position, is to be taken as:

$$a_v = f_{prob} \sqrt{a_{heave}^2 + a_{pitch-z}^2 + a_{roll-z}^2} \quad (m/s^2)$$

Where:

a_{heave} : vertical acceleration due to heave, is to be taken as
 $= f_V a_0 g \quad (m/s^2)$

$a_{pitch-z}$: vertical acceleration due to pitch, is to be taken as
 $= \left(0.3 + \frac{L_{CSR-T}}{325} \right) \varphi \left(\frac{2\pi}{U_{pitch}} \right)^2 |x - 0.45L_{CSR-T}| \quad (m/s^2)$

a_{roll-z} : vertical acceleration due to roll, is to be taken as
 $= 1.2\theta \left(\frac{2\pi}{U_{roll}} \right)^2 |y| \quad (m/s^2)$

a_0 : common acceleration parameter, as defined in **3.3.2.1**

g : acceleration due to gravity, $9.81m/s^2$

φ : pitch angle, in *rads*, as defined in **3.2.3.2**

U_{pitch} : pitch period, in *secs*, as defined in **3.2.3.1**

L_{CSR-T} : rule length, in m , as defined in **Section 4/1.1.1.1**

θ : roll angle, in *rads*, as defined in **3.2.2.2**

U_{roll} : roll period, in *secs*, as defined in **3.2.2.1**

x : longitudinal coordinate, in m

y : transverse coordinate, in m

f_{prob} : as defined in **3.3.3.2** and **3.3.3.3** as appropriate

f_V : as defined in **3.3.3.2** and **3.3.3.3** as appropriate

3.3.3.2 For scantling requirements and strength assessment:

f_{prob} is to be taken as 1.0

f_V is to be taken as 1.0

3.3.3.3 For fatigue strength:

f_{prob} is to be taken as 0.45

$$f_V = \left(\frac{C_{b-LC}}{C_b} \right)^2 \left(1.2 - \frac{L_{CSR-T}}{1000} \right)$$

Where:

C_{b-LC} : block coefficient for considered loading condition, as defined in **Section 4/1.1.9.2**

C_b : block coefficient, as defined in **Section 4/1.1.9.1**

L_{CSR-T} : rule length, in m , as defined in **Section 4/1.1.1.1**

3.3.4 Transverse acceleration

3.3.4.1 The envelope transverse acceleration, a_t , at any position, is to be taken as:

$$a_t = f_{prob} \sqrt{a_{sway}^2 + (g \sin \theta + a_{roll-y})^2} \quad (m/s^2)$$

Where:

a_{sway} : transverse acceleration due to sway and yaw, is to be taken as
 $= 0.3ga_0$ (m/s²)

a_{roll-y} : transverse acceleration due to roll, is to be taken as
 $= \theta \left(\frac{2\pi}{U_{roll}} \right)^2 R_{roll}$ (m/s²)

θ : roll angle, in *rads*, as defined in **3.2.2.2**

U_{roll} : roll period, in *secs*, as defined in **3.2.2.1**

R_{roll} = $z - \left(\frac{D}{4} + \frac{T_{LC}}{2} \right)$ or $z - \left(\frac{D}{2} \right)$, whichever is the greater, in *m*

g : acceleration due to gravity, 9.81m/s²

a_0 : common acceleration parameter, as defined in **3.3.2.1**

T_{LC} : draught in the loading condition being considered, in *m*

D : moulded depth, as defined in **Section 4/1.1.4.1**

z : vertical coordinate, in *m*

f_{prob} : as defined in **3.3.4.2** or **3.3.4.3** as appropriate

3.3.4.2 For scantling requirements and strength assessment:

f_{prob} is to be taken as 1.0

3.3.4.3 For fatigue strength:

f_{prob} is to be taken as 0.5

3.3.5 Longitudinal acceleration

3.3.5.1 The envelope longitudinal acceleration, a_{lng} , at any position, is to be taken as:

$$a_{lng} = 0.7 f_{prob} \sqrt{a_{surge}^2 + \left(\frac{L_{CSR-T}}{325} (g \sin \varphi + a_{pitch-x}) \right)^2} \quad (m/s^2)$$

Where:

a_{surge} : longitudinal acceleration due to surge, is to be taken as
 $= 0.2ga_0$ (m/s²)

$a_{pitch-x}$: longitudinal acceleration due to pitch, is to be taken as
 $= f_V \phi (2\pi / U_{pitch})^2 R_{pitch}$ (m/s²)

φ : pitch angle, in *rads*, as defined in **3.2.3.2**

U_{pitch} : pitch period, in *secs*, as defined in **3.2.3.1**

: pitch radius and is to be taken as the greater of

R_{pitch} = $z - \left(\frac{D}{4} + \frac{T_{LC}}{2} \right)$ or $z - \left(\frac{D}{2} \right)$, in *m*

g : acceleration due to gravity, 9.81m/s²

a_0 : common acceleration parameter, as defined in **3.3.2.1**

T_{LC} : draught in the loading condition being considered, in *m*

D : moulded depth, in *m*, as defined in **Section 4/1.1.4.1**

L_{CSR-T} : rule length, in *m*, as defined in **Section 4/1.1.1.1**

z : vertical coordinate, in *m*

f_{prob} : as defined in **3.3.5.2** and **3.3.5.3** as appropriate

f_V : as defined in **3.3.5.2** and **3.3.5.3** as appropriate

3.3.5.2 For scantling requirements and strength assessment:

f_{prob} is to be taken as 1.0

f_V is to be taken as 1.0

3.3.5.3 For fatigue strength:

f_{prob} is to be taken as 0.5
 f_V is to be taken as 1.7

3.4 Dynamic Hull Girder Loads

3.4.1 Vertical wave bending moment

3.4.1.1 The envelope hogging and sagging vertical wave bending moments, M_{wv-hog} and M_{wv-sag} , are to be taken as:

$$M_{wv-hog} = f_{prob} 0.19 f_{wv-v} C_{wv} L_{CSR-T}^2 B C_b \quad (kNm)$$

$$M_{wv-sag} = -f_{prob} 0.11 f_{wv-v} C_{wv} L_{CSR-T}^2 B (C_b + 0.7)$$

Where:

f_{wv-v} : distribution factor for vertical wave bending moment along the vessel length, see 3.4.1.2 or 3.4.1.3 as appropriate

C_{wv} : wave coefficient to be taken as

$$= 10.75 - \left(\frac{300 - L_{CSR-T}}{100} \right)^2 \quad \text{for } 150 \leq L_{CSR-T} \leq 300$$

$$= 10.75 \quad \text{for } 300 < L_{CSR-T} \leq 350$$

$$= 10.75 - \left(\frac{L_{CSR-T} - 350}{150} \right)^2 \quad \text{for } 350 < L_{CSR-T} \leq 500$$

L_{CSR-T} : rule length, in *m*, as defined in Section 4/1.1.1.1

B : moulded breadth, in *m*, as defined in Section 4/1.1.3.1

C_b : block coefficient, as defined in Section 4/1.1.9.1

3.4.1.2 For scantling requirements and strength assessment:

f_{wv-v} : distribution factor for vertical wave bending moment along the vessel length, is to be taken as

- 0.0 at A.P.
- 1.0 for $0.4L_{CSR-T}$ to $0.65L_{CSR-T}$ from A.P.
- 0.0 at F.P.

intermediate values to be obtained by linear interpolation, see Fig. 7.3.1

f_{prob} is to be taken as 1.0

L_{CSR-T} : rule length, in *m*, as defined in Section 4/1.1.1.1

Fig. 7.3.1 Vertical and Horizontal Wave Bending Moment Distribution for Scantling Requirements and Strength Assessment

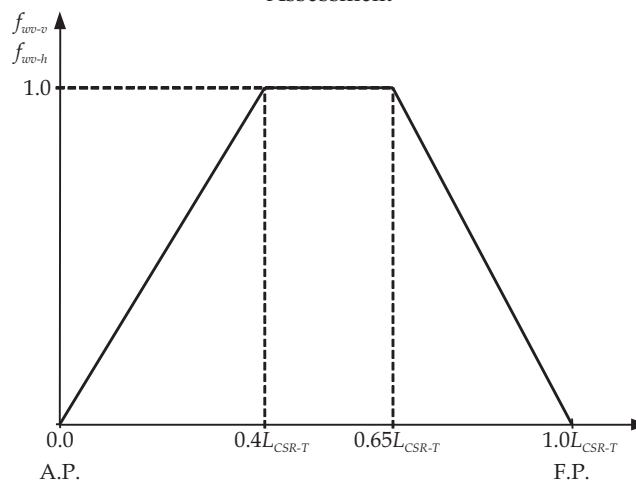

3.4.1.3 For fatigue strength:

- f_{wv-v} : distribution factor for vertical wave bending moment along the vessel length, is to be taken as
 0.0 at A.P.
 0.1 at $0.1L_{CSR-T}$ from A.P.
 1.0 for $0.4L_{CSR-T}$ to $0.65L_{CSR-T}$ from A.P.
 0.1 at $0.9L_{CSR-T}$ from A.P.
 0.0 at F.P.
 intermediate values to be obtained by linear interpolation, see **Fig. 7.3.2**
- f_{prob} is to be taken as 0.5
- L_{CSR-T} : rule length, in m , as defined in **Section 4/1.1.1.1**

Fig. 7.3.2 Vertical and Horizontal Wave Bending Moment Distribution for Fatigue Strength

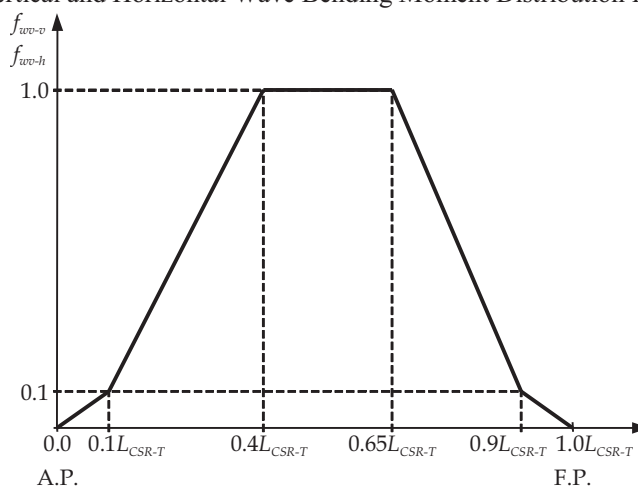

3.4.2 Horizontal wave bending moment

 3.4.2.1 The envelope horizontal wave bending moment, M_{wv-h} , is to be taken as:

$$M_{wv-h} = f_{prob} \left(0.3 + \frac{L_{CSR-T}}{2000} \right) f_{wv-h} C_{wv} L_{CSR-T}^2 T_{LC} C_b \quad (kNm)$$

Where:

- f_{wv-h} : distribution factor for wave horizontal bending moment along the vessel length, see **3.4.2.2** or **3.4.2.3** as appropriate
- C_{wv} : wave coefficient, as defined in **3.4.1.1**
- L_{CSR-T} : rule length, in m , as defined in **Section 4/1.1.1.1**
- T_{LC} : draught in the loading condition being considered, in m
- C_b : block coefficient, as defined in **Section 4/1.1.9.1**

3.4.2.2 For scantling requirements and strength assessment:

- f_{wv-h} : distribution factor for wave horizontal bending moment along the vessel length, is to be taken as
 0.0 at A.P.
 1.0 for $0.4L_{CSR-T}$ to $0.65L_{CSR-T}$ from A.P.
 0.0 at F.P.
 intermediate values to be obtained by linear interpolation, see **Fig. 7.3.1**

f_{prob} is to be taken as 1.0

L_{CSR-T} : rule length, in m , as defined in **Section 4/1.1.1.1**

3.4.2.3 For fatigue strength:

- f_{wv-h} : distribution factor for wave horizontal bending moment along the vessel length, is to be taken as
 0.0 at A.P.

- 0.1 at $0.1L_{CSR-T}$ from A.P.
- 1.0 for $0.4L_{CSR-T}$ to $0.65L_{CSR-T}$ from A.P.
- 0.1 at $0.9L_{CSR-T}$ from A.P.
- 0.0 at F.P.

intermediate values to be obtained by linear interpolation, see **Fig. 7.3.2**

f_{prob} is to be taken as 0.5

L_{CSR-T} : rule length, in m , as defined in **Section 4/1.1.1.1**

3.4.3 Vertical wave shear force

3.4.3.1 The envelope positive and negative vertical wave shear forces, Q_{wv-pos} and Q_{wv-neg} , are to be taken as:

$$Q_{wv-pos} = 0.3 f_{qvv-pos} C_{wv} L_{CSR-T} B (C_b + 0.7) \quad (kN)$$

$$Q_{wv-neg} = -0.3 f_{qvv-neg} C_{wv} L_{CSR-T} B (C_b + 0.7)$$

Where:

$f_{qvv-pos}$: distribution factor for positive vertical wave shear force along the vessel length and is to be taken as

- 0.0 at A.P.
- $1.59 \frac{C_b}{(C_b + 0.7)}$ for $0.2L_{CSR-T}$ to $0.3L_{CSR-T}$ from A.P.
- 0.7 for $0.4L_{CSR-T}$ to $0.6L_{CSR-T}$ from A.P.
- 1.0 for $0.7L_{CSR-T}$ to $0.85L_{CSR-T}$ from A.P.
- 0.0 at F.P.

$f_{qvv-neg}$: distribution factor for negative vertical wave shear force along the vessel length and is to be taken as

- 0.0 at A.P.
- 0.92 for $0.2L_{CSR-T}$ to $0.3L_{CSR-T}$ from A.P.
- 0.7 for $0.4L_{CSR-T}$ to $0.6L_{CSR-T}$ from A.P.
- $1.73 \frac{C_b}{(C_b + 0.7)}$ for $0.7L_{CSR-T}$ to $0.85L_{CSR-T}$ from A.P.
- 0.0 at F.P.

intermediate values of $f_{qvv-pos}$ and $f_{qvv-neg}$ are to be obtained by linear interpolation, see **Fig. 7.3.3** and **Fig. 7.3.4** respectively.

C_{wv} : wave coefficient, as defined in **3.4.1.1**

L_{CSR-T} : rule length, in m , as defined in **Section 4/1.1.1.1**

B : moulded breadth, in m , as defined in **Section 4/1.1.3.1**

C_b : block coefficient, as defined in **Section 4/1.1.9.1**

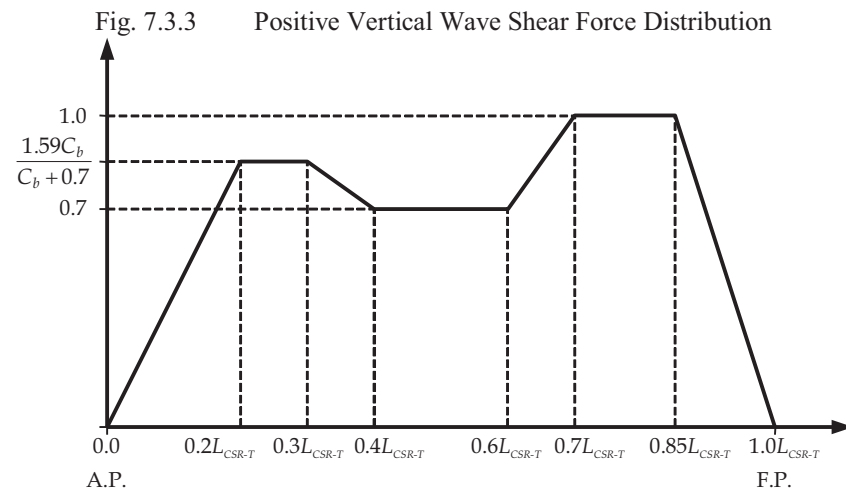

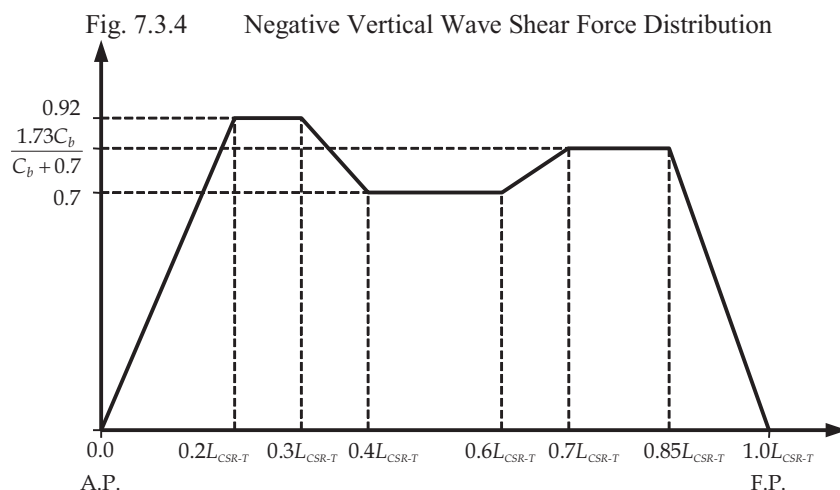

3.5 Dynamic Local Loads

3.5.1 General

3.5.1.1 This section provides the envelope values for dynamic wave pressure, dynamic tank pressure, green sea load and dynamic deck loads.

3.5.1.2 The envelope dynamic wave pressures are given in 3.5.2

3.5.1.3 The envelope green sea load given in 3.5.3 only applies to scantling requirements and strength assessment. The green sea load for fatigue strength is to be taken as 0.

3.5.1.4 The envelope dynamic tank pressure is a combination of the inertial components due to vertical, transverse and longitudinal acceleration. The envelope dynamic tank pressure components are given in 3.5.4.

3.5.1.5 The envelope dynamic deck loads are given in 3.5.5 and 3.5.6.

3.5.2 Dynamic wave pressure

3.5.2.1 The envelope dynamic wave pressure, P_{ex-dyn} , is to be taken as the greater of the following:

$$P_1 = 2f_{prob} f_{nl-P1} \left[\left(P_{11} + \frac{135B_{local}}{4(B+75)} - 1.2(T_{LC} - z) \right) f_1 + \frac{135B_{local}}{4(B+75)} f_2 \right] \quad (kN/m^2)$$

$$P_2 = 26f_{prob} f_{nl-P2} \left[\left(\frac{B_{local}}{8} \theta + f_T C_b \frac{0.25B_{local} + 0.8C_{wv}}{14} \left(0.7 + \frac{2z}{T_{LC}} \right) \right) f_1 + \left(\frac{B_{local}}{8} \theta + f_T C_b \frac{0.25B_{local}}{14} \left(0.7 + \frac{2z}{T_{LC}} \right) \right) f_2 \right] \quad (kN/m^2)$$

Where:

B_{local} : local breadth at the waterline, for considered draught, not to be taken less than $0.5B$, in m

θ : roll angle, in $rads$, as defined in 3.2.2.2

$P_{11} = (3f_s + 0.8)C_{wv}$

C_{wv} : wave coefficient, as defined in 3.4.1.1

L_{CSR-T} : rule length, in m , as defined in Section 4/1.1.1.1

B : moulded breadth, in m , as defined in Section 4/1.1.3.1

T_{LC} : draught in the loading condition being considered, in m

T_{sc} : scantling draught, in m , as defined in Section 4/1.1.5.5

C_b : block coefficient, as defined in Section 4/1.1.9.1

$$f_1 = f_{lng} - \frac{f_{lng}}{f_V} f_2 + f_2$$

$$f_2 = 0.25f_V \left(\frac{4|y|}{B_{local}} - 1 \right) \quad \text{for } |y| < 0.25B_{local}$$

$$= f_V \left(\frac{4|y|}{B_{local}} - 1 \right) \quad \text{for } |y| \geq 0.25B_{local}$$

$$f_T = \frac{T_{LC}}{T_{sc}}$$

$$f_s = C_b + \frac{1.33}{\sqrt{C_b}} \quad \text{at, and aft of A.P.}$$

$$= C_b \quad \text{between } 0.2L_{CSR-T} \text{ and } 0.7L_{CSR-T} \text{ from A.P.}$$

$$= C_b + \frac{1.33}{C_b} \quad \text{at, and forward of F.P.}$$

intermediate values to be obtained by linear interpolation

$$f_{ing} = 1.0 \quad \text{at, and aft of A.P.}$$

$$= 0.7 \quad \text{for } 0.2L_{CSR-T} \text{ to } 0.7L_{CSR-T} \text{ from A.P.}$$

$$= 1.0 \quad \text{at, and forward of F.P.}$$

intermediate values to be obtained by linear interpolation

y transverse coordinate, in m
 z vertical coordinate, in m

f_{nl-P1} , f_{nl-P2} , f_{prob} , and f_V are given in 3.5.2.2 for scantling requirements and strength assessment application and in 3.5.2.3 for fatigue strength.

3.5.2.2 For scantling requirements and strength assessment, the envelope maximum dynamic wave pressure, P_{ex-max} , see Fig. 7.3.5, and minimum dynamic wave pressure, P_{ex-min} , see Fig. 7.3.6, are to be taken as:

$$P_{ex-max} = P_{ex-dyn} \quad (kN/m^2) \quad \text{below still waterline}$$

$$= P_{WL} - 10(z - T_{LC}) \quad (kN/m^2) \quad \text{for } T_{LC} < z \leq T_{LC} + \frac{P_{WL}}{10}$$

$$= 0 \quad (kN/m^2) \quad \text{for } z > T_{LC} + \frac{P_{WL}}{10}$$

$$P_{ex-min} = -P_{ex-dyn} \quad (kN/m^2) \quad \text{below still waterline}$$

$$= 0 \quad (kN/m^2) \quad \text{above still waterline}$$

P_{ex-min} is not to be taken as less than $-\rho_{sw}g(T_{LC} - z)$

Where:

P_{ex-dyn} : envelope dynamic wave pressure, in kN/m^2 , as defined in 3.5.2.1 with

$$f_{prob} = 1.0$$

$$f_{nl-P1} = 0.9$$

$$f_{nl-P2} = 0.65$$

$$f_V = 1.0$$

P_{WL} : pressure at waterline, to be taken as P_{ex-dyn} at still waterline, in kN/m^2

T_{LC} : draught in the loading condition being considered, in m

ρ_{sw} : density of sea water, $1.025 \text{ tonnes}/m^3$

z : vertical coordinate, in m

Fig. 7.3.5 Transverse Distribution of Maximum Dynamic Wave Pressure for Scantling Requirements and Strength Assessment

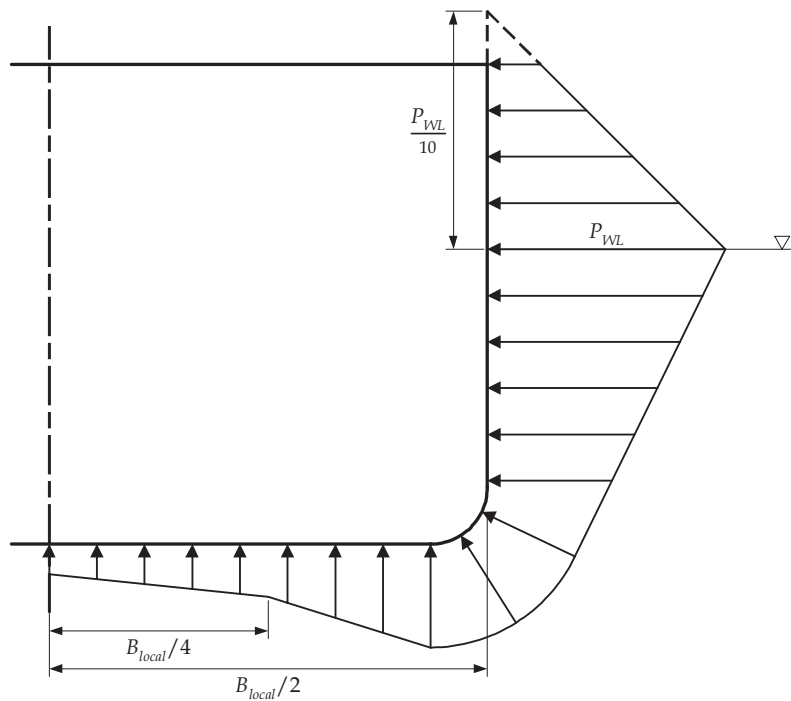
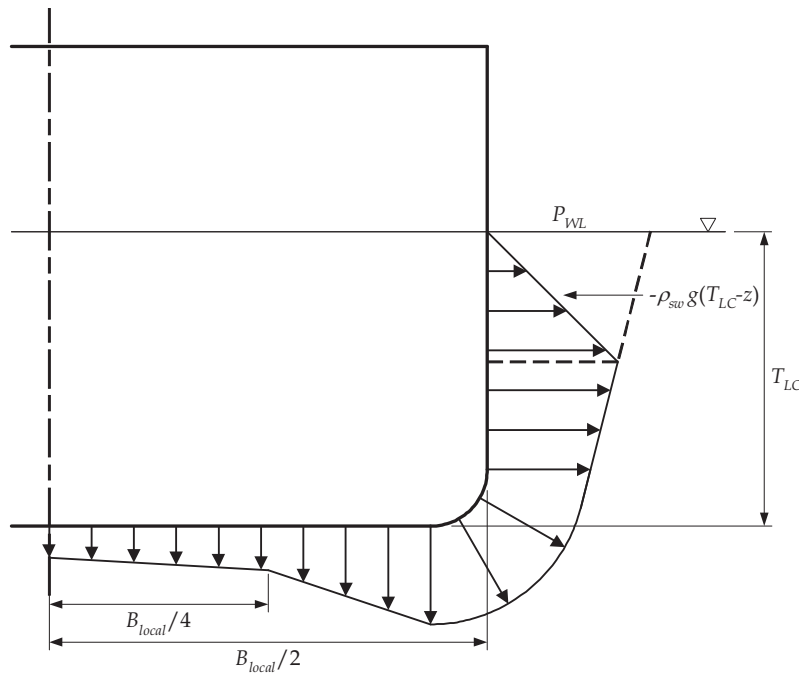

Fig. 7.3.6 Transverse Distribution of Minimum Dynamic Wave Pressure for Scantling Requirements and Strength Assessment



3.5.2.3 The dynamic wave pressure pseudo-amplitude (half range), P_{ex-amp} for fatigue strength, see Fig. 7.3.7, is to be taken as:

$$\begin{aligned}
 P_{ex-amp} &= 0 \quad (kN/m^2) && \text{for } z \geq T_{LC} + h_{WL} \text{ or } D, \text{ whichever is the lesser} \\
 &= 0.5 P_{WL} \quad (kN/m^2) && \text{at still waterline} \\
 &= P_{ex-dyn} \quad (kN/m^2) && \text{for } z \leq T_{LC} - h_{WL} \text{ or } 0, \text{ whichever is the greater}
 \end{aligned}$$

Intermediate values between the still waterline and $z = T_{LC} - h_{WL}$ to be obtained by linear interpolation

Where:

h_{WL} : dynamic wave pressure head at the still waterline, is to be taken as
 $= P_{WL}/10$ (m)

P_{WL} : pressure at waterline, and is to be taken as P_{ex-max} at still waterline, in kN/m^2

P_{ex-max} : envelope maximum dynamic wave pressure is to be taken as the greater of P_1 and P_2 , in kN/m^2

T_{LC} : draught in the loading condition being considered, in m

D : moulded depth, in m, as defined in **Section 4/1.1.4.1**

P_1 : as defined in **3.5.2.**, in kN/m^2 , with

$$f_{prob} = 0.5$$

$$f_{nl-P1} = 1.0$$

$$f_V = \begin{cases} 1.0 & \text{at, and aft of } 0.7L_{CSR-T} \\ 1.5 & \text{at, and forward of F.P.} \end{cases}$$

intermediate values of f_V to be obtained by linear interpolation

P_2 : as defined in **3.5.2.1**, in kN/m^2 , with

$$f_{prob} = 0.5$$

$$f_{nl-P2} = 1.0$$

$$f_V = 1.0$$

z : vertical coordinate, in m

Fig. 7.3.7 Transverse Distribution of Dynamic Wave Pressure Amplitude for Fatigue Strength

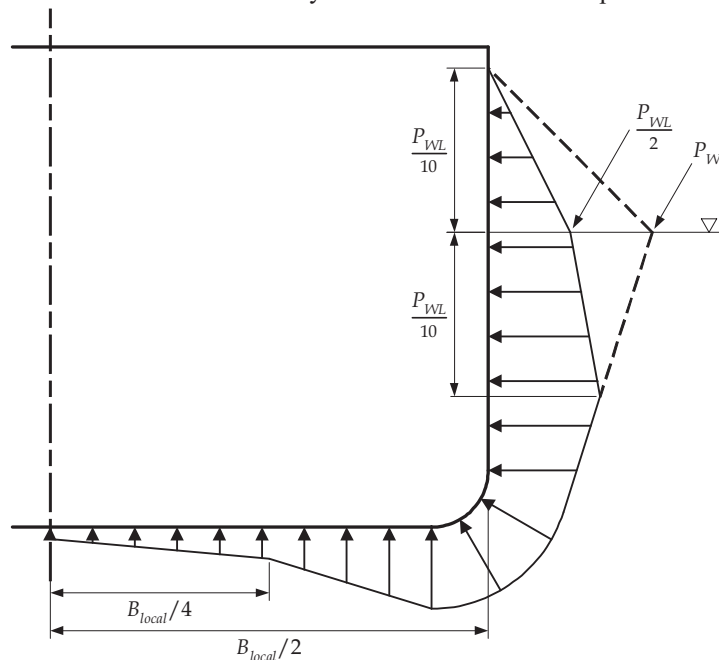

3.5.3 Green sea load

3.5.3.1 The envelope green sea load on the weather deck, P_{wdk} , is to be taken as the greater of the following:

$$P_{wdk} = f_{1-dk} (f_{op} P_{1-WL} - 10z_{dk-T}) \quad (kN/m^2)$$

$$P_{wdk} = 0.8 f_{2-dk} (P_{2-WL} - 10z_{dk-T}) \quad (kN/m^2)$$

$$P_{wdk} = 34.3 \quad (kN/m^2)$$

Where:

$$f_{1-dk} = 0.8 + \frac{L_{CSR-T}}{750}$$

$$f_{2-dk} = 0.5 + \frac{|y|}{B_{wdk}}$$

f_{op}	= 1.0 at and forward of $0.2L_{CSR-T}$ from A.P. = 0.8 at and aft of A.P. intermediate values to be obtained by linear interpolation
P_{1-WL}	: P_1 pressure at still waterline for considered draught, in kN/m^2 , see 3.5.2.1
P_{2-WL}	: P_2 pressure at still waterline for considered draught, in kN/m^2 , see 3.5.2.1
z_{dk-T}	: distance from the deck to the still waterline at the applicable draught for the loading condition being considered, in m
B_{wdk}	: local breadth at the weather deck, in m
L_{CSR-T}	: rule length, in m , as defined in Section 4/1.1.1.1
y	: transverse coordinate of load point, in m

3.5.4 Dynamic tank pressure

3.5.4.1 The envelope dynamic tank pressure, P_{in-v} , due to vertical tank acceleration is to be taken as:

$$P_{in-v} = \rho \alpha_v (z_0 - z) \quad (kN/m^2) \quad \text{for strength assessment and scantling requirements}$$

$$P_{in-v} = \rho \alpha_v |z_0 - z| \quad (kN/m^2) \quad \text{for fatigue strength}$$

Where:

ρ : density of liquid in the tank, in $tonnes/m^3$, and is not to be taken as less than 0.9 for cargo tanks for fatigue strength

1.025 otherwise, see **Section 2/3.1.8**

α_v : envelope vertical acceleration, in m/s^2 , as defined in **3.3.3.1**, and is to be taken at tank centre of gravity

z : vertical coordinate of load point, in m

z_0 : vertical coordinate of reference point, see **6.3.7** for scantling requirements and strength assessment, and **3.5.4.5** for fatigue strength, in m

3.5.4.2 The envelope dynamic tank pressure, P_{in-t} , due to transverse acceleration is to be taken as:

$$P_{in-t} = f_{ull-t} \rho \alpha_t (y_0 - y) \quad (kN/m^2) \quad \text{for strength assessment and scantling requirements}$$

$$P_{in-t} = \rho \alpha_t |y_0 - y| \quad (kN/m^2) \quad \text{for fatigue strength}$$

Where:

ρ : density of liquid in the tank, in $tonnes/m^3$, and is not to be taken as less than 0.9 for cargo tanks for fatigue strength

1.025 otherwise, see **Section 2/3.1.8**

f_{ull-t} : factor to account for ullage in cargo tanks, and is to be taken as

0.67 for cargo tanks, including cargo tanks designed for filling with water ballast

1.0 for ballast and other tanks

α_t : envelope transverse acceleration, in m/s^2 , as defined in **3.3.4.1**, and is to be taken at tank centre of gravity

y : transverse coordinate of load point, in m

y_0 : transverse coordinate of reference point, see **6.3.7** for scantling requirements and strength assessment, and **3.5.4.5** for fatigue strength, in m

3.5.4.3 The envelope dynamic tank pressure, P_{in-lng} , due to longitudinal acceleration is to be taken as:

$$P_{in-lng} = f_{ull-lng} \rho \alpha_{lng} (x_0 - x) \quad (kN/m^2) \quad \text{for strength assessment and scantling requirements}$$

$$P_{in-lng} = \rho \alpha_{lng} |x_0 - x| \quad (kN/m^2) \quad \text{for fatigue strength}$$

Where:

ρ : density of tank liquid, in $tonnes/m^3$, and is not to be taken as less than 0.9 for cargo tanks for fatigue strength

1.025 otherwise, see **Section 2/3.1.8**

$f_{ull-lng}$: factor to account for ullage in cargo tanks, and is to be taken as

0.62 for cargo tanks, including cargo tanks designed for filling with water ballast

1.0 for ballast and other tanks

- a_{lng} : envelope longitudinal acceleration, in m/s^2 , as defined in **3.3.5.1**, and is to be taken at tank centre of gravity
- x : longitudinal coordinate of load point, in m
- x_0 : longitudinal coordinate of reference point, see **6.3.7** for scantling requirements and strength assessment, and **3.5.4.5** for fatigue strength, in m

3.5.4.4 For scantling requirements and strength assessment the simultaneous acting dynamic tank pressure, P_{in-dyn} , is to be taken as the summation of the components for the considered dynamic load case, see **6.3.7**.

3.5.4.5 For fatigue strength the dynamic tank pressure amplitude, P_{in-amp} , on a tank boundary with adjacent tank empty, is to be taken as:

$$P_{in-amp} = f_v P_{in-v} + f_{ull-t} f_t P_{in-t} + f_{ull-lng} f_{lng} P_{in-lng} \quad (kN/m^2)$$

Where:

P_{in-v} : envelope dynamic tank pressure due to vertical acceleration, in kN/m^2 , as defined in **3.5.4.1**

P_{in-t} : envelope dynamic tank pressure due to transverse acceleration, in kN/m^2 , as defined in **3.5.4.2**

P_{in-lng} : envelope dynamic tank pressure due to longitudinal acceleration, in kN/m^2 , as defined in **3.5.4.3**

f_{ull-t} : factor to account for ullage in cargo tanks, not to be taken less than 0.0 nor greater than 1.0
 $= \frac{|z_0 - z| + h_{roll}}{2h_{roll}}$ for cargo tanks

$= 1.0$ for ballast tanks

$f_{ull-lng}$: factor to account for ullage in cargo tanks, not to be taken less than 0.0 nor greater than 1.0
 $= \frac{|z_0 - z| + h_{pitch}}{2h_{pitch}}$ for cargo tanks

$= 1.0$ for ballast tanks

h_{roll} : roll height $= \frac{b_{fs} f_{prob} \theta}{2}$

h_{pitch} : pitch height $= \frac{l_{fs} f_{prob} \varphi}{2}$

f_{prob} is to be taken as 0.5

θ : roll angle, in *rads*, as defined in **3.2.2.2**

φ : pitch angle, in *rads*, as defined in **3.2.3.2**

b_{fs} : tank breadth at the top of the tank, see **Fig. 7.3.8**, in m

l_{fs} : tank length at the top of the tank, in m

x_0 : longitudinal coordinate of reference point, and is to be taken as the middle of tank length at the top of the tank, in m

y_0 : transverse coordinate of reference point, and is to be taken as the middle of tank breadth at the top of the tank, see **Fig. 7.3.8**, in m

z_0 : vertical coordinate of reference point, and is to be taken as the highest point of the tank, excluding small hatchways, see **Fig. 7.3.8**, in m

f_v : pressure combination factor, as given in **Table 7.3.2**

f_t : pressure combination factor, as given in **Table 7.3.2**

f_{lng} : pressure combination factor, as given in **Table 7.3.2**

3.5.4.6 For fatigue strength the dynamic tank pressure amplitude, P_{in-amp} , on a longitudinal tank boundary with adjacent tank full, is to be taken as:

$$P_{in-amp} = f_v |P_{in-v-tk1} - P_{in-v-tk2}| + f_t |f_{ull-t-tk1} P_{in-t-tk1} + f_{ull-t-tk2} P_{in-t-tk2}| + f_{lng} |f_{ull-lng-tk1} P_{in-lng-tk1} - f_{ull-lng-tk2} P_{in-lng-tk2}| \quad (kN/m^2)$$

Where:

- $P_{in-v-tk1}$: dynamic tank pressure due to vertical acceleration in tank 1, in kN/m^2
- $P_{in-v-tk2}$: dynamic tank pressure due to vertical acceleration in tank 2, in kN/m^2
- $P_{in-t-tk1}$: dynamic tank pressure due to transverse acceleration in tank 1, in kN/m^2
- $P_{in-t-tk2}$: dynamic tank pressure due to transverse acceleration in tank 2, in kN/m^2
- $P_{in-lng-tk1}$: dynamic tank pressure due to longitudinal acceleration in tank 1, in kN/m^2
- $P_{in-lng-tk2}$: dynamic tank pressure due to longitudinal acceleration in tank 2, in kN/m^2
- $f_{ull-t-tk1}$: factor to account for ullage for tank 1, as defined in 3.5.4.5
- $f_{ull-t-tk2}$: factor to account for ullage for tank 2, as defined in 3.5.4.5
- $f_{ull-lng-tk1}$: factor to account for ullage for tank 1, as defined in 3.5.4.5
- $f_{ull-lng-tk2}$: factor to account for ullage for tank 2, as defined in 3.5.4.5
- f_v : pressure combination factor, as given in Table 7.3.2
- f_t : pressure combination factor, as given in Table 7.3.2
- f_{lng} : pressure combination factor, as given in Table 7.3.2

Tank 1 and 2 are adjacent tanks with common longitudinal boundary

Table 7.3.2 Pressure Combination Factors for Fatigue Assessment

	Cargo tanks	Ballast tanks
f_v	0.9	0.9
f_t	0.9	0.6
f_{lng}	0.4	0.4

Fig. 7.3.8 Dynamic Tank Pressure Load and Reference Points for Fatigue Strength

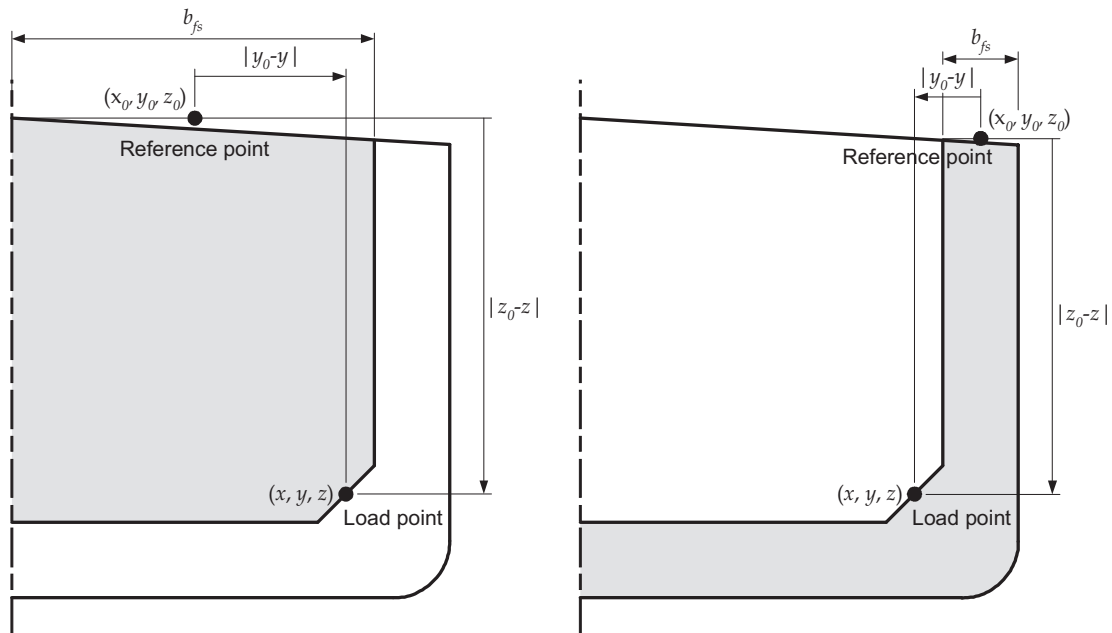

3.5.4.7 For fatigue strength by hot spot stress (FE) approach, the dynamic tank pressure amplitudes due to vertical, transverse and longitudinal accelerations, illustrated in **Fig. 7.3.9** are to be taken as:

$$P_{in-v} = \rho a_v (z_0 - z) \quad \text{in } kN/m^2$$

$$P_{in-t} = f_{ull-t} \rho a_t (y_0 - y) \quad \text{in } kN/m^2$$

$$P_{in-lng} = f_{ull-lng} \rho a_{lng} (x_0 - x) \quad \text{in } kN/m^2$$

Where:

- ρ : density of liquid in the tank, in $tonnes/m^3$, and is not to be taken as less than 0.9 for cargo tanks
1.025 otherwise, see **Section 2/3.1.8**
- f_{ull-t} : factor to account for ullage in cargo tanks, as defined in **3.5.4.5**
- $f_{ull-lng}$: factor to account for ullage in cargo tanks, as defined in **3.5.4.5**
- x : longitudinal coordinate of load point, in m
- y : transverse coordinate of load point, in m
- z : vertical coordinate of load point, in m
- x_0 : longitudinal coordinate of reference point, and is to be taken as the middle of the tank length at the top of the tank, in m
- y_0 : transverse coordinate of reference point, and is to be taken as the middle of the tank breadth at the top of the tank, in m
- z_0 : vertical coordinate of reference point, and is to be taken as the highest point in the tank, in m
- a_v : envelope vertical acceleration, in m/s^2 , as defined in **3.3.3.1**, at tank centre of gravity
- a_t : envelope transverse acceleration, in m/s^2 , as defined in **3.3.4.1**, at tank centre of gravity
- a_{lng} : envelope longitudinal acceleration, in m/s^2 , as defined in **3.3.5.1**, at tank centre of gravity

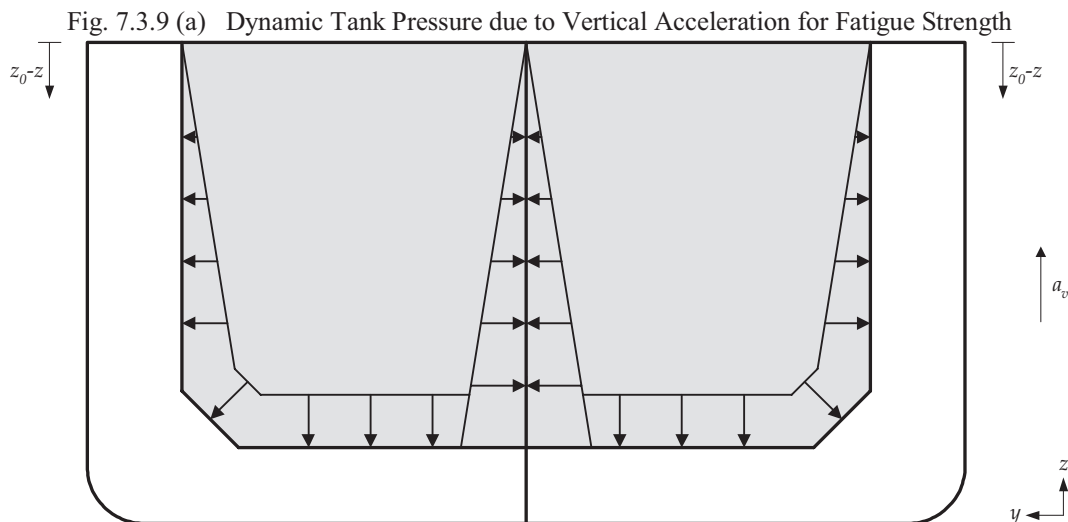

Fig. 7.3.9 (b) Dynamic Tank Pressure due to Transverse Acceleration for Fatigue Strength

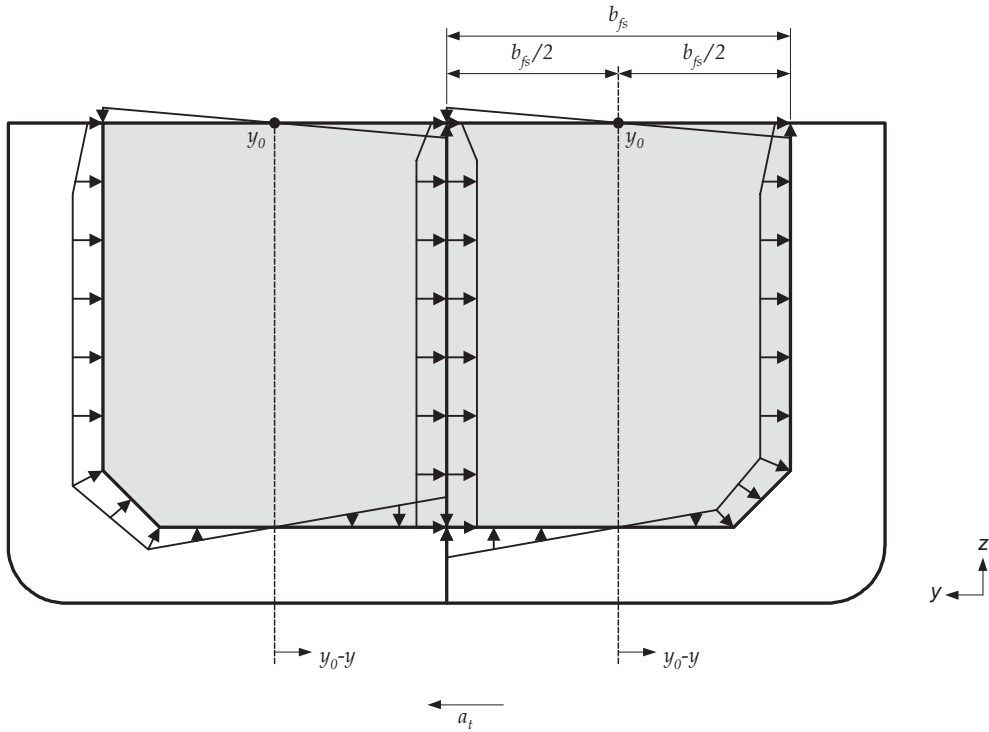
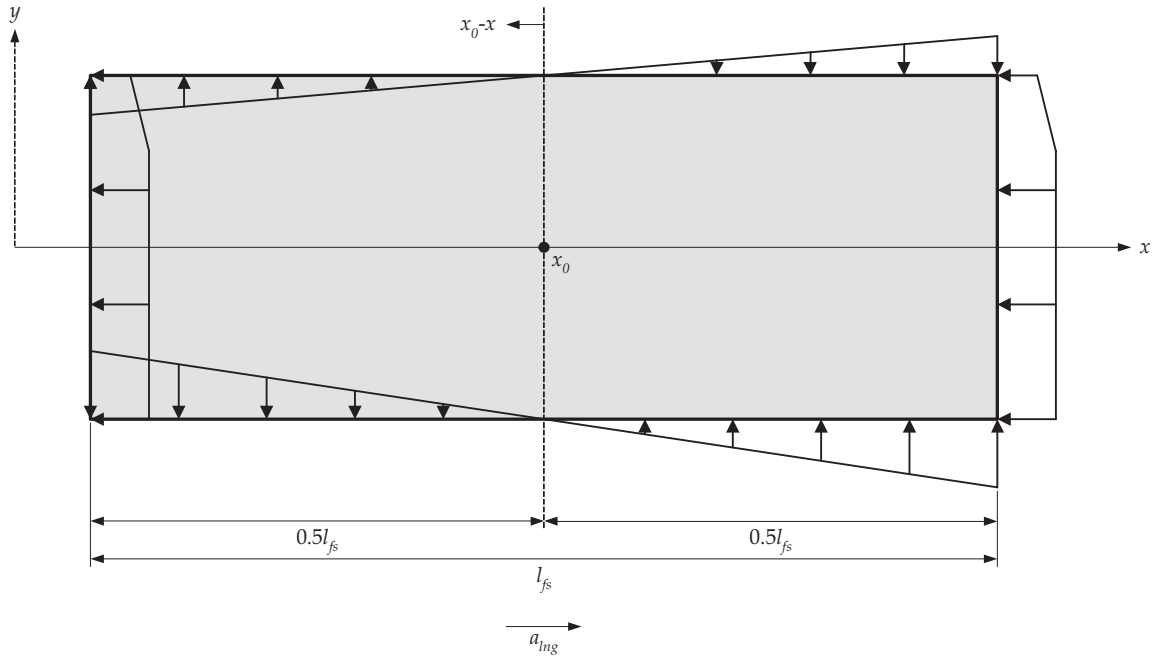

Fig. 7.3.9 (c) Dynamic Tank Pressure due to Longitudinal Acceleration for Fatigue Strength Illustrated for a Cargo Tank



3.5.5 Dynamic deck pressure from distributed loading

3.5.5.1 The envelope dynamic deck pressure, $P_{deck-dyn}$, on decks, inner bottom and hatch covers is to be taken as:

$$P_{deck-dyn} = P_{deck} \frac{a_v}{g} \quad (kN/m^2)$$

Where:

a_v : envelope vertical acceleration, in m/s^2 , as defined in 3.3.3.1

P_{deck} : uniformly distributed pressure on lower decks and decks within superstructure, in kN/m^2 , as defined in 2.2.4.1

g : acceleration due to gravity, $9.81 m/s^2$

3.5.6 Dynamic loads from heavy units

3.5.6.1 The envelope dynamic deck loads, F_v , F_t , F_{lng} acting vertically, transversely and longitudinally on supporting structures and securing systems for heavy units of cargo, equipment or structural components are to be taken as:

$$F_v = m_{un} a_v \quad (kN)$$

$$F_t = m_{un} a_t \quad (kN)$$

$$F_{lng} = m_{un} a_{lng} \quad (kN)$$

Where:

m_{un} : mass of unit, in *tonnes*

a_v : envelope vertical acceleration, in m/s^2 , as defined in 3.3.3.1, at centre of gravity of considered unit

a_t : envelope transverse acceleration, in m/s^2 , as defined in 3.3.4.1, at centre of gravity of considered unit

a_{lng} : envelope longitudinal acceleration, in m/s^2 , as defined in 3.3.5.1, at centre of gravity of considered unit

4. Sloshing and Impact Loads

4.1 General

4.1.1 Load Components

4.1.1.1 Sloshing pressures in tanks, and bow impact and bottom slamming pressures are given in this sub-section.

4.2 Sloshing Pressure in Tanks

4.2.1 Application and limitations

4.2.1.1 The sloshing pressures given in 4.2.2 to 4.2.4 are pressures induced by free movement of the tank liquids as a result of ship motions.

4.2.1.2 The given pressures do not include the effect of impact pressures due to high velocity impacts with tank boundaries or internal structures. For tanks with a maximum effective sloshing breadth, b_{slh} , greater than $0.56B$ or a maximum effective sloshing length, l_{slh} , greater than $0.13L_{CSR-T}$ at any filling height from $0.05h_{max}$ to $0.95h_{max}$, an additional impact assessment is to be carried out in accordance with the individual Classification Society procedures. The effective sloshing lengths and breadths, l_{slh} and b_{slh} , are calculated using the equations in 4.2.2.1 and 4.2.3.1 respectively.

4.2.2 Sloshing pressure due to longitudinal liquid motion

4.2.2.1 The sloshing pressure in way of transverse tight and wash bulkheads due to longitudinal liquid motion, $P_{slh-Ing}$, for a particular filling height, is to be taken as:

$$P_{slh-Ing} = \rho g l_{slh} f_{slh} \left[0.4 - \left(0.39 - \frac{1.7l_{slh}}{L_{CSR-T}} \right) \frac{L_{CSR-T}}{350} \right] \quad (kN/m^2)$$

Where:

ρ : density of liquid in the tank, in $tonnes/m^3$, and is not to be taken as less than 1.025

l_{slh} : effective sloshing length, at considered filling height as given in 4.2.2.3 and 4.2.2.4 for transverse tight bulkheads and transverse wash bulkheads respectively, in m

$$f_{slh} = 1 - 2 \left(0.7 - \frac{h_{fill}}{h_{max}} \right)^2$$

L_{CSR-T} : rule length, in m , as defined in Section 4/1.1.1.1

h_{fill} : filling height, measured from inner bottom, in m , see Fig. 7.4.1

h_{max} : maximum tank height excluding small hatchways, measured from inner bottom, in m , see Fig. 7.4.1

g : acceleration due to gravity, $9.81 m/s^2$

4.2.2.2 The sloshing pressure due to longitudinal liquid motion, $P_{slh-Ing}$, is to be taken as a constant value over the full tank depth and is to be taken as the greater of the sloshing pressures calculated for filling heights from $0.05h_{max}$ to $0.95h_{max}$, in $0.05h_{max}$ increments.

4.2.2.3 For calculation of sloshing pressures in way of transverse tight bulkheads, the effective sloshing length, l_{slh} , is to be taken as:

$$l_{slh} = \frac{(1 + n_{wash-t} \alpha_{wash-t})(1 + f_{wf} \alpha_{wf}) l_{tk-h}}{(1 + n_{wash-t})(1 + f_{wf})} \quad (m)$$

Where:

n_{wash-t} : number of transverse wash bulkheads in the tank

α_{wash-t} : transverse wash bulkhead coefficient,

$$= \frac{A_{opn-wash-t}}{A_{tk-t-h}}$$

see Fig. 7.4.1

α_{wf} : transverse web frame coefficient,

$$= \frac{A_{opn-wf-h}}{A_{tk-t-h}}$$

see **Fig. 7.4.2**

for tanks with changing shape along the length and/or with web frames of different shape the transverse web frame coefficient, α_{wf} , may be taken as the weighted average of all web frame locations in the tank given as

$$= \frac{\sum_{i=1}^n \frac{A_{opn-wf-h-i}}{A_{tk-t-h-i}}}{n_{wf}}$$

- $A_{opn-wash-t}$: total area of openings in the transverse section in way of the wash bulkhead below the considered filling height, in m^2
- A_{tk-t-h} : total transverse cross sectional area of the tank below the considered filling height, in m^2
- $A_{opn-wf-h}$: the total area of openings in the transverse section in way of the web frame below the considered filling height, in m^2
- f_{wf} : factor to account for number of transverse web frames and transverse wash bulkheads in the tank
 $= n_{wf} / (1 + n_{wash-t})$
- n_{wf} : number of transverse web frames, excluding wash bulkheads, in the tank
- l_{tk-h} : length of cargo tank, at considered filling height, in m

Fig. 7.4.1 Transverse Wash Bulkhead Coefficient

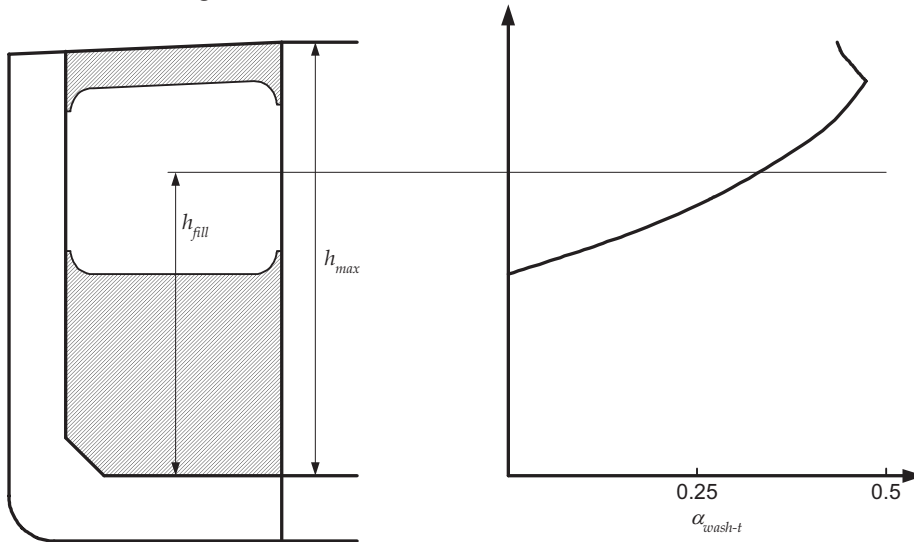

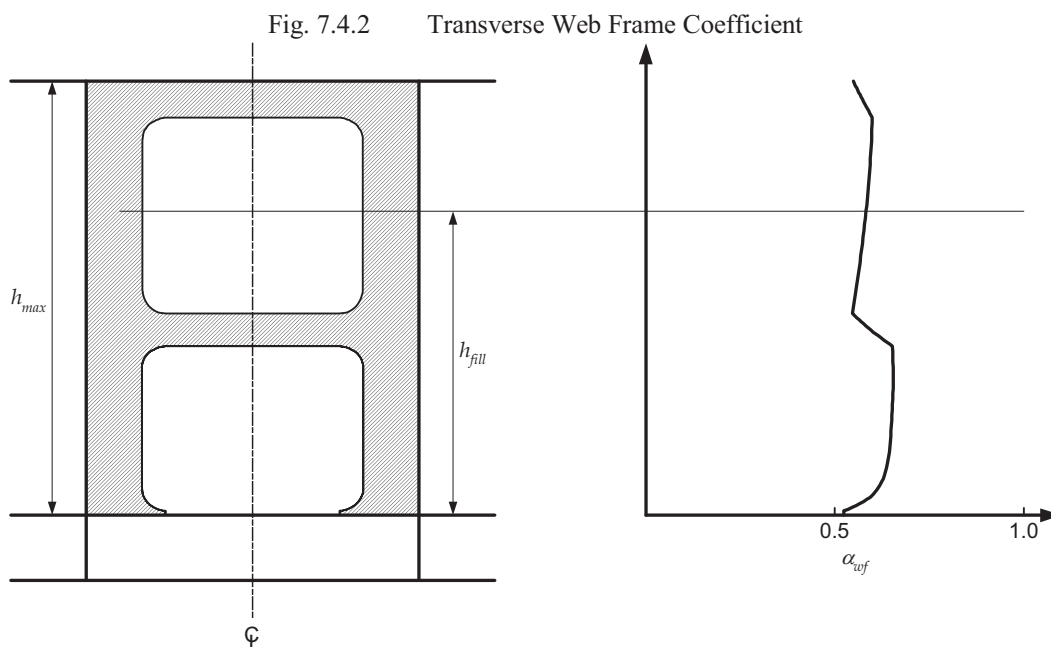

4.2.2.4 For calculation of sloshing pressures in way of transverse wash bulkheads, the effective sloshing length, l_{slh} , is to be taken as:

$$l_{slh} = \frac{[1 + (n_{wash-t} - 1)\alpha_{wash-t}](1 + f_{wf}\alpha_{wf})l_{tk-h}}{(1 + n_{wash-t})(1 + f_{wf})} \quad (m)$$

Where:

n_{wash-t} : number of transverse wash bulkheads in the tank

α_{wash-t} : transverse wash bulkhead coefficient,

$$= \frac{A_{opn-wash-t}}{A_{tk-t-h}}$$

see **Fig. 7.4.1**

α_{wf} : transverse web frame coefficient,

$$= \frac{A_{opn-wf-h}}{A_{tk-t-h}}$$

see **Fig. 7.4.2**

for tanks with changing shape along the length and/or with web frames of different shape the transverse web frame coefficient, α_{wf} , may be taken as the weighted average of all web frame locations in the tank given as

$$= \frac{\sum_{i=1}^n \frac{A_{opn-wf-h-i}}{A_{tk-t-h-i}}}{n_{wf}}$$

$A_{opn-wash-t}$: the total area of openings in the transverse section in way of the wash bulkhead below the considered filling height, in m^2

A_{tk-t-h} : total transverse cross sectional area of the tank below the considered filling height, in m^2

$A_{opn-wf-h}$: the total area of openings in the transverse section in way of the web frame below the considered filling height, in m^2

f_{wf} : factor to account for number of transverse web frames and transverse wash bulkheads in the tank

$$= n_{wf} / (1 + n_{wash-t})$$

n_{wf} : number of transverse web frames, excluding wash bulkheads, in the tank

l_{tk-h} : length of cargo tank, at considered filling height, in m

4.2.2.5 For tanks with internal web frames the sloshing pressure acting on a web frame adjacent to a transverse tight or wash bulkhead, P_{slh-wf} , provided it is located within $0.25 l_{slh}$ from the bulkhead, is to be taken as:

$$P_{slh-wf} = P_{slh-lng} \left(1 - \frac{s_{wf}}{l_{slh}} \right)^2 \quad (kN/m^2)$$

Where:

$P_{slh-lng}$: sloshing pressure acting on bulkhead due to longitudinal liquid motion, as given in **4.2.2.1**

s_{wf} : distance from bulkhead to web frame under consideration, in m

l_{slh} : effective sloshing length, at considered filling height as defined in **4.2.2.3** and **4.2.2.4** for transverse tight and wash bulkheads respectively, in m

The distribution of pressure across the web frame is given in **Fig. 7.4.3**.

4.2.2.6 For tanks with internal bulkhead stringers and/or web frames, the distribution of sloshing pressure, P_{slh} , across these members is shown in **Fig. 7.4.3**.

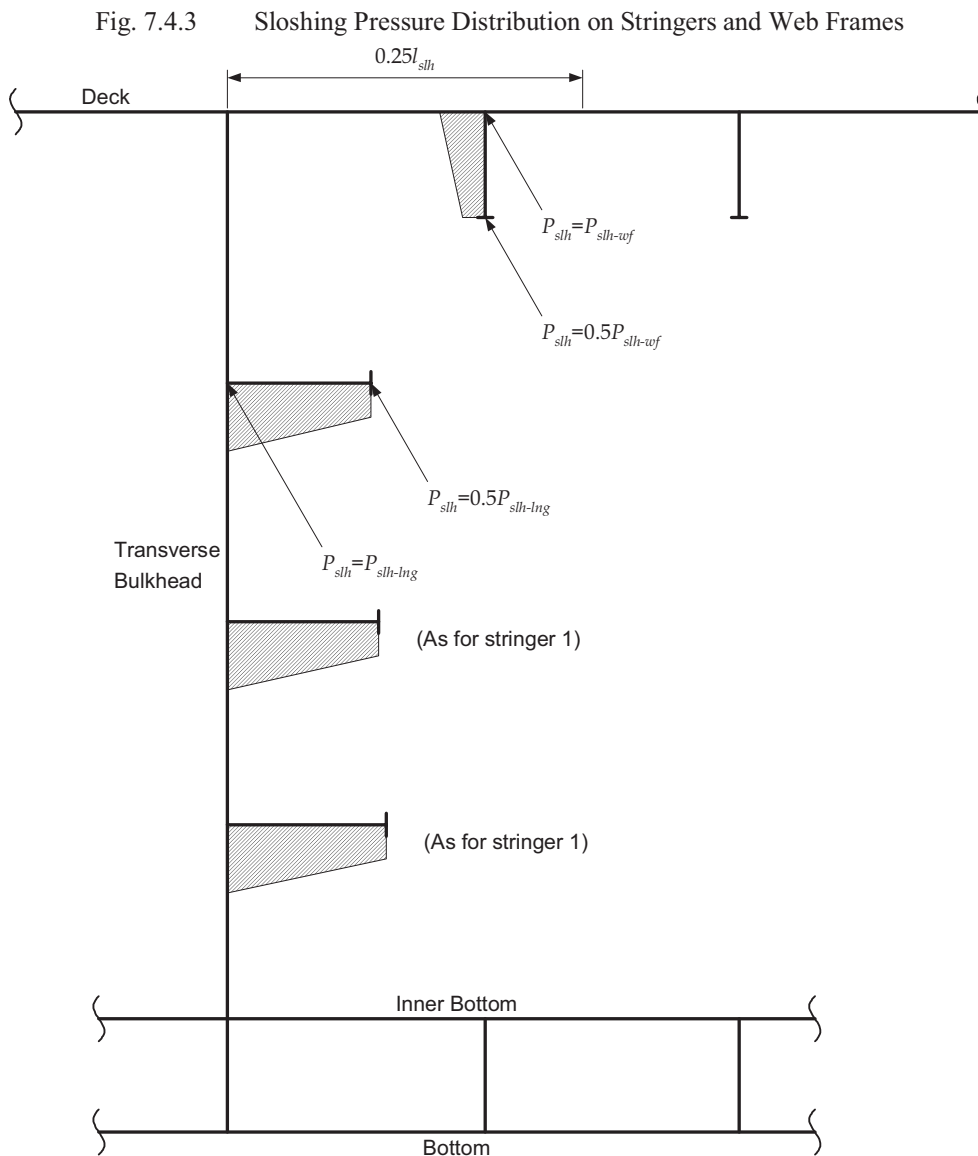

4.2.3 Sloshing pressure due to transverse liquid motion

4.2.3.1 The sloshing pressure in way of longitudinal tight and wash bulkheads due to transverse liquid motion, P_{slh-t} , for a particular filling height, is to be taken as:

$$P_{slh-t} = 7 \rho g f_{slh} \left(\frac{b_{slh}}{B} - 0.3 \right) GM^{0.75} \quad (kN/m^2)$$

Where:

ρ : density of liquid in the tank, in $tonnes/m^3$, and is not to be taken as less than 1.025

- b_{slh} : effective sloshing breadth, see 4.2.3.3 and 4.2.3.4 for longitudinal tight bulkheads and longitudinal wash bulkheads respectively, not to be taken less than $0.3B$, in m .
- GM : metacentric height, is to be taken as $0.33B$ for calculation of sloshing pressures in ballast tanks and $0.24B$ for calculation of sloshing pressure in cargo tanks

$$f_{slh} = 1 - 2 \left(0.7 - \frac{h_{fill}}{h_{max}} \right)^2$$

- B : moulded breadth, in m , as defined in Section 4/1.1.3.1
- h_{fill} : filling height, measured from inner bottom, in m , see Fig. 7.4.1
- h_{max} : maximum tank height excluding small hatchways, measured from inner bottom, in m , see Fig. 7.4.1
- g : acceleration due to gravity, $9.81m/s^2$

4.2.3.2 The sloshing pressure due to transverse liquid motion, P_{slh-t} , is to be taken as a constant value over the full tank depth and is to be taken as the greater of the sloshing pressures calculated for filling heights from $0.05h_{max}$ to $0.95h_{max}$, in $0.05h_{max}$ increments.

4.2.3.3 For calculation of sloshing pressures in way of longitudinal tight bulkheads the effective sloshing breadth, b_{slh} , is to be taken as:

$$b_{slh} = \frac{(1 + n_{wash-lng} \alpha_{wash-lng})(1 + f_{grd} \alpha_{grd}) b_{tk-h}}{(1 + n_{wash-lng})(1 + f_{grd})} \quad (m)$$

Where:

- $n_{wash-lng}$: number of longitudinal wash bulkheads in the tank
- $\alpha_{wash-lng}$: longitudinal wash bulkhead coefficient
 $= \frac{A_{opn-wash-lng}}{A_{tk-lng-h}}$
- α_{grd} : girder coefficient
 $= \frac{A_{opn-grd-h}}{A_{tk-lng-h}}$
- $A_{opn-wash-lng}$: total area of openings in the longitudinal section in way of the wash bulkhead below the considered filling height, in m^2
- $A_{tk-lng-h}$: total longitudinal cross sectional area of the tank below the considered filling height, in m^2
- $A_{opn-grd-h}$: total area of openings in the longitudinal section below the considered filling height, in m^2
- f_{grd} : factor to account for longitudinal girders and longitudinal wash bulkheads in the tank
 $= n_{grd} / (1 + n_{wash-lng})$
- n_{grd} : number of longitudinal girders, excluding longitudinal wash bulkheads, in the tank
- b_{tk-h} : tank breadth at considered filling height, in m

4.2.3.4 For calculation of sloshing pressures in way of longitudinal wash bulkheads the effective sloshing breadth, b_{slh} , is to be taken as:

$$b_{slh} = \frac{[1 + (n_{wash-lng} - 1) \alpha_{wash-lng}](1 + f_{grd} \alpha_{grd}) b_{tk-h}}{(1 + n_{wash-lng})(1 + f_{grd})} \quad (m)$$

Where:

- $n_{wash-lng}$: number of longitudinal wash bulkheads in the tank
- $\alpha_{wash-lng}$: longitudinal wash bulkhead coefficient
 $= \frac{A_{opn-wash-lng}}{A_{tk-lng-h}}$
- α_{grd} : girder coefficient
 $= \frac{A_{opn-grd-h}}{A_{tk-lng-h}}$

- $A_{\text{opn-wash-lng}}$: total area of openings in the longitudinal section in way of the wash bulkhead below the considered filling height, in m^2
- $A_{\text{tk-lng-h}}$: total longitudinal cross sectional area of the tank below the considered filling height, in m^2
- $A_{\text{opn-grd-h}}$: total area of openings in the longitudinal section below the considered filling height, in m^2
- f_{grd} : factor to account for longitudinal girders and longitudinal wash bulkheads in the tank
 $= n_{\text{grd}} / (1 + n_{\text{wash-lng}})$
- n_{grd} : number of longitudinal girders, excluding longitudinal wash bulkheads, in the tank
- $b_{\text{tk-h}}$: tank breadth at considered filling height, in m

4.2.3.5 For tanks with internal longitudinal girders or webframes, the sloshing pressure on the girder/webframe adjacent to a longitudinal wash bulkhead, $P_{\text{slh-grd}}$, provided it is located within $0.25b_{\text{slh}}$ from the bulkhead, is to be taken as:

$$P_{\text{slh-grd}} = P_{\text{slh-t}} \left(1 - \frac{s_{\text{grd}}}{b_{\text{slh}}} \right)^2 \quad (kN/m^2)$$

Where:

- $P_{\text{slh-t}}$: sloshing pressure acting on bulkhead due to transverse liquid motion, in kN/m^2 , see **4.2.3.1**
- s_{grd} : distance from longitudinal bulkhead to longitudinal girder being considered, in m
- b_{slh} : effective sloshing breadth, see **4.2.3.3** and **4.2.3.4** for longitudinal tight bulkheads and longitudinal wash bulkheads respectively, in m

4.2.3.6 For tanks with internal longitudinal stringers and or girders/webframes, the distribution of sloshing pressure across these members is shown in **Fig. 7.4.4**.

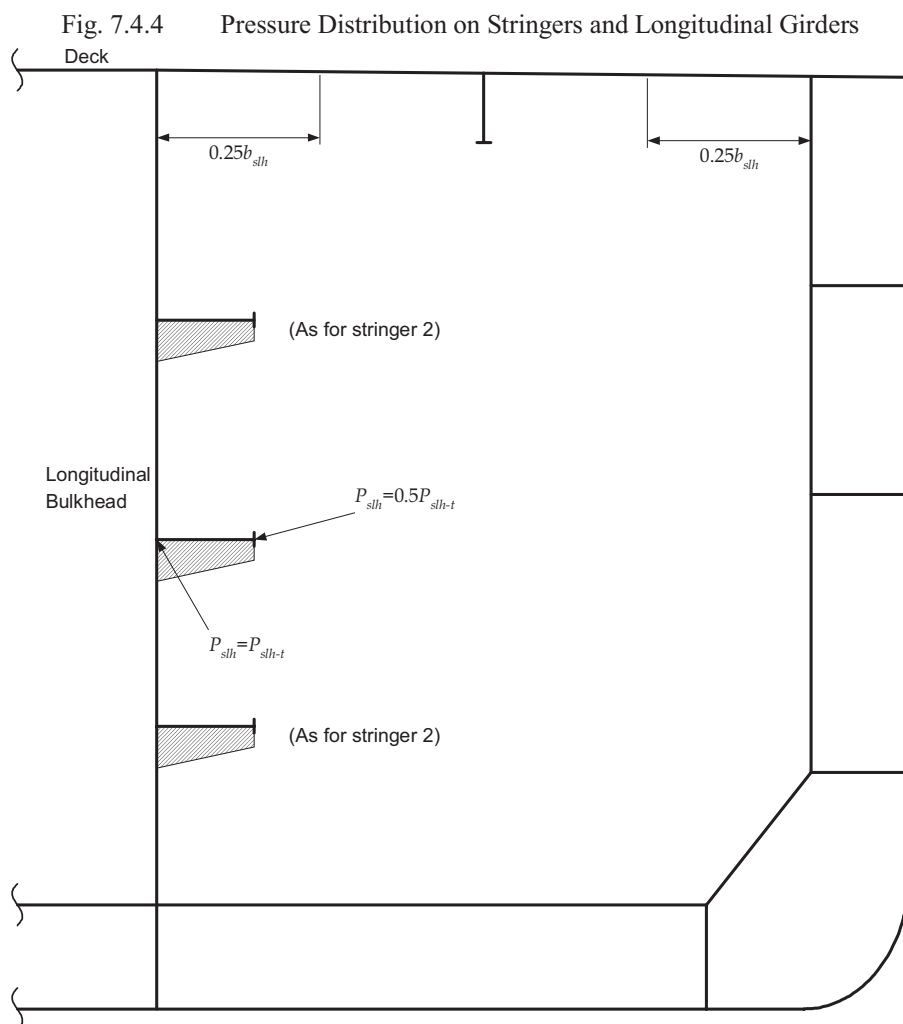

4.2.4 Minimum sloshing pressure

4.2.4.1 The minimum sloshing pressure, $P_{slh-min}$, in cargo and ballast tanks except tanks of cellular construction is to be taken as $20kN/m^2$.

4.2.4.2 The minimum sloshing pressure, $P_{slh-min}$, in cellular construction ballast tanks is to be taken as $12kN/m^2$.

4.3 Bottom Slamming Loads

4.3.1 Application and limitations

4.3.1.1 The slamming loads in this section apply to ships with $C_b \geq 0.7$ and bottom slamming draught $\geq 0.01L_{CSR-T}$ and $\leq 0.045L_{CSR-T}$.

4.3.2 Slamming pressure

4.3.2.1 The bottom slamming pressure, P_{slm} , is to be taken as the greater of:

$$P_{slm-mt} = f_{slm} 130gc_{slm-mt}e^{c_1} \quad kN/m^2 \quad \text{for empty ballast tanks}$$

$$P_{slm-full} = f_{slm} 130gc_{slm-full}e^{c_1} - c_{av} \rho g z_{ball} \quad kN/m^2 \quad \text{for full ballast tanks}$$

Where:

g : acceleration due to gravity, 9.81 m/s^2

f_{slm} : longitudinal slamming distribution factor, see **Fig. 7.4.5**, is to be taken as

0 at $0.5L_{CSR-T}$

1 at $[0.175 - 0.5(C_{bl} - 0.7)]L_{CSR-T}$ from F.P.

1 at $[0.1 - 0.5(C_{bl} - 0.7)]L_{CSR-T}$ from F.P.

0.5 at, and forward of F.P.

intermediate values to be obtained by linear interpolation.

- C_{bl} : block coefficient, C_b , as defined in **Section 4/1.1.9.1**, but not to be taken less than 0.7 or greater than 0.8
- c_{slm-mt} : slamming coefficient for empty ballast tanks

$$= 5.95 - 10.5 \left(\frac{T_{FP-mt}}{L_{CSR-T}} \right)^{0.2}$$
- $c_{slm-full}$: slamming coefficient for full ballast tanks

$$= 5.95 - 10.5 \left(\frac{T_{FP-full}}{L_{CSR-T}} \right)^{0.2}$$
- c_I is to be taken as

$$0 \quad \text{for } L_{CSR-T} \leq 180m$$

$$= -0.0125(L_{CSR-T} - 180)^{0.705} \quad \text{for } L_{CSR-T} > 180m$$
- T_{FP-mt} : design slamming ballast draught at F.P. with ballast tanks within the bottom slamming region empty as defined in **4.3.2.3**, in m
- $T_{FP-full}$: design slamming ballast draught at F.P. with ballast tanks within the bottom slamming region full as defined in **4.3.2.4**, in m
- c_{av} : dynamic load coefficient, to be taken as **1.25**
- L_{CSR-T} : rule length, in m , as defined in **Section 4/1.1.1.1**
- z_{ball} : vertical distance from tank top to load point, in m

4.3.2.2 The designer is to provide the design slamming draughts T_{FP-mt} and $T_{FP-full}$.

4.3.2.3 The design slamming draught at the F.P., T_{FP-mt} , is not to be greater than the minimum draught at the F.P. indicated in the loading manual for all seagoing conditions wherein the ballast tanks within the bottom slamming region are empty. This includes any loading conditions with tanks inside the bottom slamming region that use the “sequential” ballast water exchange method.

4.3.2.4 The design slamming draught at the F.P., $T_{FP-full}$, is not to be greater than the minimum draught at the F.P. indicated in the loading manual for any seagoing conditions wherein the ballast tanks within the bottom slamming region are full. This includes any loading condition with tanks inside the bottom slamming region that use the “flow-through” ballast water exchange method.

4.3.2.5 The loading guidance information is to clearly indicate the design slamming draughts and the ballast water exchange method used for each ballast tank, see **Section 8/1.1**.

Fig. 7.4.5 Longitudinal Distribution of Slamming Pressure

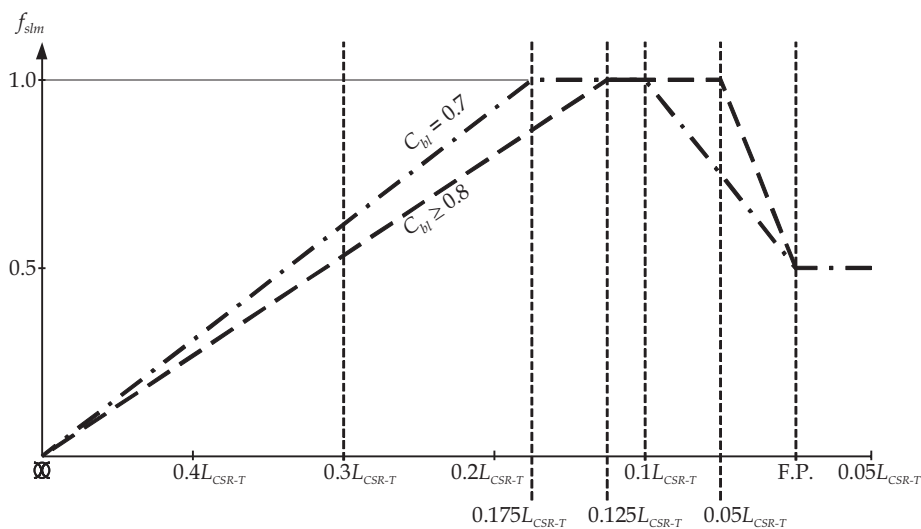

4.4 Bow Impact Loads

4.4.1 Application and limitations

4.4.1.1 The bow impact pressure applies to the side structure in the area forward of $0.1L_{CSR-T}$ aft of F.P. and between the waterline at draught T_{bal} and the highest deck at side.

4.4.2 Bow impact pressure

4.4.2.1 The bow impact pressure, P_{im} , is to be taken as:

$$P_{im} = 1.025 f_{im} c_{im} V_{im}^2 \sin \gamma_{wl} \quad (kN/m^2)$$

Where:

- f_{im} 0.55 at $0.1L_{CSR-T}$ aft of F.P.
 0.9 at $0.0125L_{CSR-T}$ aft of F.P.
 1.0 at and forward of F.P.
 intermediate values to be obtained by linear interpolation
- V_{im} : impact speed, in m/s
 $= 0.514V_{fwd} \sin \alpha_{wl} + \sqrt{L_{CSR-T}}$
- V_{fwd} : forward speed, in knots
 $= 0.75V$ but is not to be taken as less than 10
- V : service speed, in knots, as defined in **Section 4/1.1.8.1**
- α_{wl} : local waterline angle at the position considered, but is not to be taken as less than 35 degrees, see **Fig. 7.4.6**.
- γ_{ol} : local bow impact angle measured normal to the shell from the horizontal to the tangent line at the position considered but is not to be less than 50 degrees, see **Fig. 7.4.6**.
- c_{im} 1.0 for positions between draughts T_{bal} and T_{sc}
 $= \sqrt{1 + \cos^2 \left[90 \frac{(h_{fb} - 2h_o)}{h_{fb}} \right]}$ for positions above draught T_{sc}
- h_{fb} : vertical distance from the waterline at draught T_{sc} to the highest deck at side, see **Fig. 7.4.6**, in m
- h_o : vertical distance from the waterline at draught T_{sc} , to the position considered, see **Fig. 7.4.6**, in m
- L_{CSR-T} : rule length, in m , as defined in **Section 4/1.1.1.1**
- T_{sc} : scantling draught, in m , as defined in **Section 4/1.1.5.5**
- T_{bal} : minimum design ballast draught, in m , for the normal ballast condition as defined in **Section 4/1.1.5.2**
- WL_j : waterline at the position considered, see **Fig. 7.4.6**

Guidance Note

Where local bow impact angle measured normal to the shell, γ_{ol} , is not available, this angle may be taken as:

$$\gamma_{ol} = \tan^{-1} \left(\frac{\tan \beta_{pl}}{\cos \alpha_{wl}} \right)$$

Where

β_{pl} local body plan angle at the position considered from the horizontal to the tangent line, but is not to be less than 35 degrees

Fig. 7.4.6 Definition of Bow Geometry

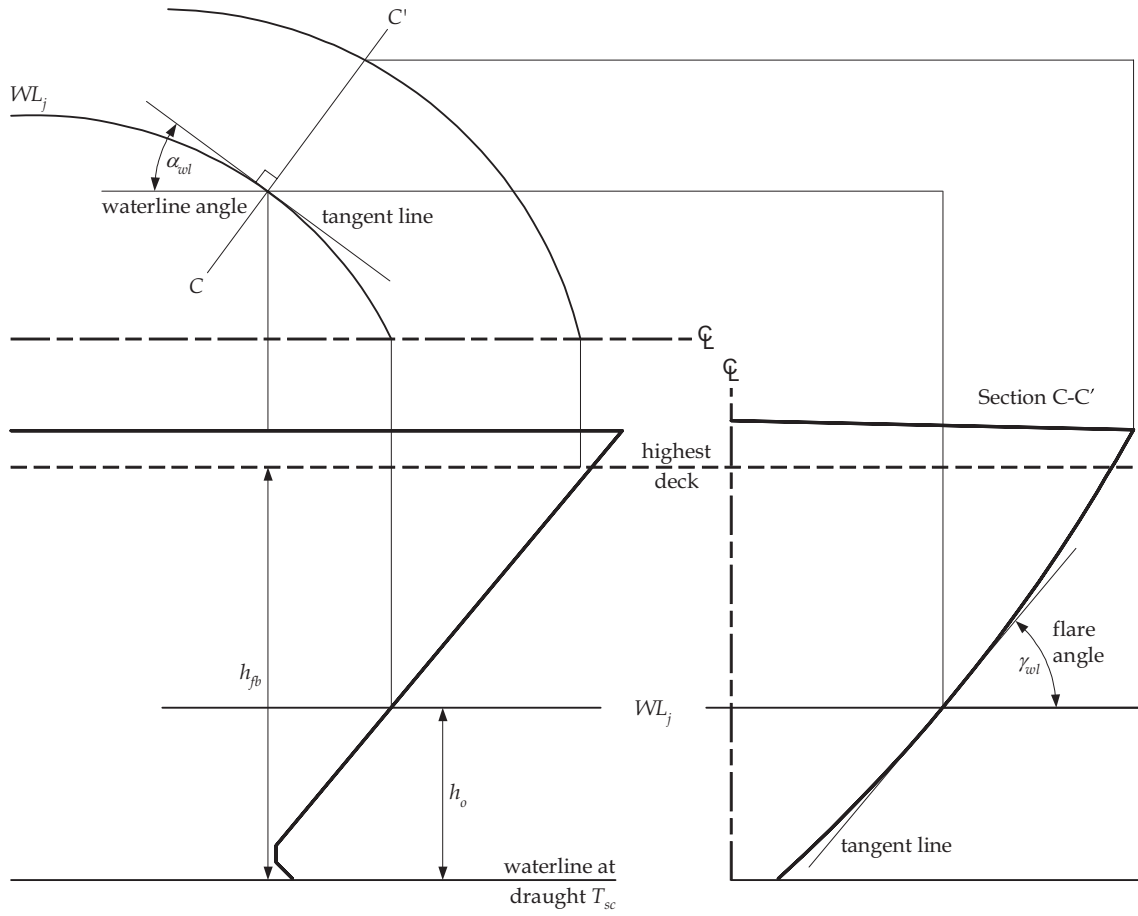

5. Accidental Loads

5.1 Flooded Condition

5.1.1 Local Pressure

5.1.1.1 The pressure in compartments and tanks in flooded condition or damaged condition is to be taken as $P_{in-flood}$, see 2.2.3.4.

6. Combination of Loads

6.1 General

6.1.1 Application

6.1.1.1 The design load combinations S , $S + D$, and A are to be used for scantling calculations for the scantling requirements and strength assessment (by FEM). design load combinations are defined in **Section 2/4.2.2** and the relevant loads and load combination are to be taken as given in **6.2**.

6.1.1.2 The dynamic loads, D , consist of several dynamic load cases. For each dynamic load case, the envelope load values as given in **Sub-Section 3** are multiplied with dynamic load combination factors to give simultaneously acting dynamic loads. The procedures for calculating the simultaneously acting dynamic loads are given in **6.3**. The dynamic load combination factors are given in **6.4** for strength assessment (by FEM) and in **6.5** for scantling requirements.

6.2 Design Load Combination

6.2.1 General

6.2.1.1 The design load combinations are given in **Table 7.6.1**.

Table 7.6.1 Design Load Combinations

Design Load Combination		S	S + D	A
Load components				
$M_{y-total}$		$M_{sw-harb}$	$M_{sw-sea} + M_{wv}$	-
$M_{h-total}$		-	M_h	-
Q		$Q_{sw-harb}$	$Q_{sw-sea} + Q_{wv}$	-
P_{ex}	Weather Deck	-	$P_{wdk-dyn}$	-
	Hull envelope	P_{hys}	$P_{hys} + P_{wv-dyn}$	-
P_{in}	Ballast tanks (BWE with sequential filling method)	the greater of a) $P_{in-test}$ b) $P_{in-air} + P_{drop}$	$P_{in-tk} + P_{in-dyn}$	$P_{in-flood}$
	Ballast tanks (BWE with flow-through method)	the greater of a) $P_{in-test}$ b) $P_{in-air} + P_{drop}$	$P_{in-air} + P_{drop} + P_{in-dyn}$	$P_{in-flood}$
	Cargo tanks including cargo tanks designed for filling with water ballast	the greater of a) $P_{in-test}$ b) $P_{in-tk} + P_{valve}$	$P_{in-tk} + P_{valve} - 25 + P_{in-dyn}$	-
	Other tanks with liquid filling	the greater of a) $P_{in-test}$ b) P_{in-air}	$P_{in-tk} + P_{in-dyn}$	$P_{in-flood}$
	Watertight boundaries	-	-	$P_{in-flood}$
P_{dk}	Internal decks for dry spaces	P_{stat}	$P_{stat} + P_{dk-dyn}$	-
	Decks for heavy units	F_{stat}	$F_{stat} + F_{dk-dyn}$	-

Note:

1. Separate load requirements may be specified in strength assessment (FEM) and scantling requirements.

Table 7.6.1 (Continued) Design Load Combinations

Where:

$M_{v-total}$: design vertical bending moment, in kNm	
$M_{sw-perm-harb}$: permissible hull girder hogging and sagging still water bending moment envelopes for harbour/sheltered water operation, in kNm	see 2.1.1
$M_{sw-perm-sea}$: permissible hull girder hogging and sagging still water bending moment envelopes for seagoing operation, in kNm	see 2.1.1
M_{wv}	: vertical wave bending moment for a considered dynamic load case, in kNm	see 6.3.2.1
$M_{h-total}$: design horizontal bending moment, in kNm	
M_h	: horizontal wave bending moment for a considered dynamic load case, in kNm	see 6.3.3.1
Q	: design vertical shear force, in kN	
$Q_{sw-perm-harb}$: permissible hull girder positive and negative still water shear force limits for harbour/sheltered water operation, in kN	see 2.1.3
$Q_{sw-perm-sea}$: permissible hull girder positive and negative still water shear force limits for seagoing operation, in kN	see 2.1.3
Q_{wv}	: vertical wave shear force for a considered dynamic load case, in kN	see 6.3.4.1
P_{ex}	: design sea pressure, in kN/m^2	
P_{hys}	: static sea pressure at considered draught, in kN/m^2	see 2.2.2.1
P_{wv-dyn}	: dynamic wave pressure for a considered dynamic load case, in kN/m^2	see 6.3.5
$P_{wdk-dyn}$: green sea load for a considered dynamic load case, in kN/m^2	see 6.3.6
P_{in}	: design tank pressure, in kN/m^2	
$P_{in-test}$: tank testing pressure, in kN/m^2	see 2.2.3.5
P_{in-air}	: static tank pressure in the case of overfilling or filling during flow through ballast water exchange, in kN/m^2	see 2.2.3.2
P_{drop}	: added overpressure due to liquid flow through air pipe or overflow pipe, in kN/m^2	see 2.2.3.3
P_{valve}	: setting of pressure relief valve, in kN/m^2	see 2.2.3.5
P_{in-tk}	: static tank pressure, in kN/m^2	see 2.2.3.1
P_{in-dyn}	: dynamic tank pressure for a considered dynamic load case, in kN/m^2	see 6.3.7
$P_{in-flood}$: pressure in compartments and tanks in flooded or damaged condition, in kN/m^2	see 2.2.3.4
P_{stat}	: static pressure on decks and inner bottom, in kN/m^2	see 2.2.4.1
P_{dk}	: design deck pressure, in kN/m^2	
P_{dk-dyn}	: dynamic deck pressure on decks, inner bottom and hatch covers for a considered dynamic load case, in kN/m^2	see 6.3.8.1
F_{stat}	: load acting on supporting structures and securing systems for heavy units of cargo, equipment or structural components, in kN	see 2.2.5.1
F_{dk-dyn}	: dynamic load acting on supporting structures and securing systems for heavy units of cargo, equipment or structural components, in kN	see 6.3.8.2

6.3 Application of Dynamic Loads

6.3.1 Heading correction factor and dynamic load combination factors

6.3.1.1 The heading correction factor, f_{β} , is to be taken as:

$$f_{\beta} = 0.8 \quad \text{for beam sea dynamic load cases}$$

$$= 1.0 \quad \text{for all other dynamic load cases}$$

6.3.1.2 The dynamic load combination factors used for the calculations of the simultaneously acting dynamic loads, are to be taken as given in **Table 7.6.2** for strength assessment by FEM, see **6.4**. Dynamic load factors are to be taken as given in **Table 7.6.4** to **Table 7.6.9** for scantling assessment, see **6.5**.

6.3.2 Vertical wave bending moment for a considered dynamic load case

6.3.2.1 The simultaneously acting vertical wave bending moment, M_{wv} , is to be taken as:

$$M_{wv} = f_{\beta} f_{mv} M_{wv-hog} \quad (kNm) \quad \text{for } f_{mv} \geq 0$$

$$M_{wv} = -f_{\beta} f_{mv} M_{wv-sag} \quad (kNm) \quad \text{for } f_{mv} < 0$$

Where:

- M_{wv-hog} : hogging vertical wave bending moment, in kNm , as defined in **3.4.1.1**
- M_{wv-sag} : sagging vertical wave bending moment, in kNm , as defined in **3.4.1.1**
- f_{mv} : dynamic load combination factor for vertical wave bending moment for considered dynamic load case, see **6.3.1.2**
- f_{β} : heading correction factor, as defined in **6.3.1.1**

6.3.3 Horizontal wave bending moment for a considered dynamic load case

6.3.3.1 The simultaneously acting horizontal wave bending moment, M_h , is to be taken as:

$$M_h = f_{\beta} f_{mh} M_{wv-h} \quad (kNm)$$

Where:

- M_{wv-h} : horizontal wave bending moment, in kNm , as defined in **3.4.2**
- f_{mh} : dynamic load combination factor for horizontal wave bending moment for considered dynamic load case, see **6.3.1.2**
- f_{β} : heading correction factor, as defined in **6.3.1.1**

6.3.4 Vertical wave shear force for a considered dynamic load case

6.3.4.1 The simultaneously acting vertical wave shear force, Q_{wv} , is to be taken as:

$$Q_{wv} = f_{\beta} f_{qv} Q_{wv-pos} \quad (kN) \quad \text{for } f_{qv} \geq 0$$

$$Q_{wv} = -f_{\beta} f_{qv} Q_{wv-neg} \quad (kN) \quad \text{for } f_{qv} < 0$$

Where:

- Q_{wv-pos} : envelope positive vertical wave shear force, in kN , as defined in **3.4.3**
- Q_{wv-neg} : envelope negative vertical wave shear force, in kN , as defined in **3.4.3**
- f_{qv} : dynamic load combination factor for vertical wave shear force for considered dynamic load case, see **6.3.1.2**
- f_{β} : heading correction factor, as defined in **6.3.1.1**

6.3.5 Dynamic wave pressure distribution for a considered dynamic load case

6.3.5.1 The simultaneously acting dynamic wave pressure, P_{wv-dyn} , for the port and starboard side within the cargo tank region for a considered dynamic load case is to be taken as follows, but not to be less than $-\rho_{sw}g(T_{LC} - z)$ below still waterline or less than 0 above still waterline:

$$P_{wv-dyn} = P_{ctr} + \frac{|y|}{0.5B_{local}} (P_{bilge} - P_{ctr}) \quad \text{between centreline and start of bilge}$$

$$P_{wv-dyn} = P_{bilge} + \frac{z}{T_{LC}} (P_{WL} - P_{bilge}) \quad \text{between end of bilge and still waterline}$$

$$P_{wv-dyn} = P_{WL} - 10(z - T_{LC}) \quad \text{for side-shell above still waterline}$$

intermediate values of P_{wv-dyn} around the bilge are to be obtained by linear interpolation along the vertical distance

Where:

- P_{ctr} : dynamic wave pressure at bottom centreline, to be taken as:
 $= f_{ctr} P_{ex-max} \quad (kN/m^2)$
- P_{bilge} : dynamic wave pressure at $z = 0$ and $y = B_{local}/2$, to be taken as
 $= f_{bilge} P_{ex-max} \quad (kN/m^2)$
- P_{WL} : dynamic wave pressure at waterline, to be taken as
 $= f_{WL} P_{ex-max} \quad (kN/m^2)$
- P_{ex-max} : envelope maximum dynamic wave pressure, in kN/m^2 , as defined in **3.5.2.2**
- f_{WL} : dynamic load combination factor for dynamic wave pressure at still waterline for considered dynamic load case, see **6.3.1.2**
- f_{bilge} : dynamic load combination factor for dynamic wave pressure at bilge for considered dynamic load case, see **6.3.1.2**
- f_{ctr} : dynamic load combination factor for dynamic wave pressure at centreline for considered dynamic load case, see **6.3.1.2**

B_{local}	: local breadth at waterline for considered draught, in m
T_{LC}	: draught in the loading condition being considered, in m
y	: transverse coordinate, in m
z	: vertical coordinate, in m
ρ_{sw}	: density of sea water, $1.025 \text{tonnes}/m^3$
g	: acceleration due to gravity, $9.81 \text{m}/s^2$

6.3.5.2 The simultaneously acting dynamic wave pressure for the port and starboard side outside the cargo region, P_{wv-dyn} , for a considered dynamic load case is to be obtained by linear interpolation between P_{ctr} and P_{WL} , but not to be taken less than $-\rho_{sw}g(T_{LC} - z)$ below still waterline or less than 0 above still waterline.

$$P_{wv-dyn} = P_{ctr} + \frac{z}{T_{LC}}(P_{WL} - P_{ctr}) \quad \text{between bottom centreline and still waterline}$$

$$P_{wv-dyn} = P_{WL} - 10(z - T_{LC}) \quad \text{above still waterline}$$

Where:

P_{ctr} dynamic wave pressure at bottom centreline, and is to be taken as:

$$f_{ctr} P_{ex-max} \quad kN/m^2$$

P_{WL} dynamic wave pressure at still waterline, and is to be taken as:

$$f_{WL} P_{ex-max} \quad kN/m^2$$

P_{ex-max} envelope maximum dynamic wave pressure, in kN/m^2 , as defined in **3.5.2.2**

f_{WL} dynamic load combination factor for dynamic wave pressure at still waterline for considered dynamic load case, see **6.3.1.2**

f_{ctr} dynamic load combination factor for dynamic wave pressure at centreline for considered dynamic load case, see **6.3.1.2**

T_{LC} draught in the loading condition being considered, in m

z vertical coordinate, in m

ρ_{sw} density of sea water, $1.025 \text{tonnes}/m^3$

g acceleration due to gravity, $9.81 \text{m}/s^2$

6.3.5.3 **Fig. 7.6.1** to **Fig. 7.6.3** illustrates simultaneously acting dynamic wave pressures.

Fig. 7.6.1 Dynamic Wave Pressure for Head Sea Dynamic Load Cases

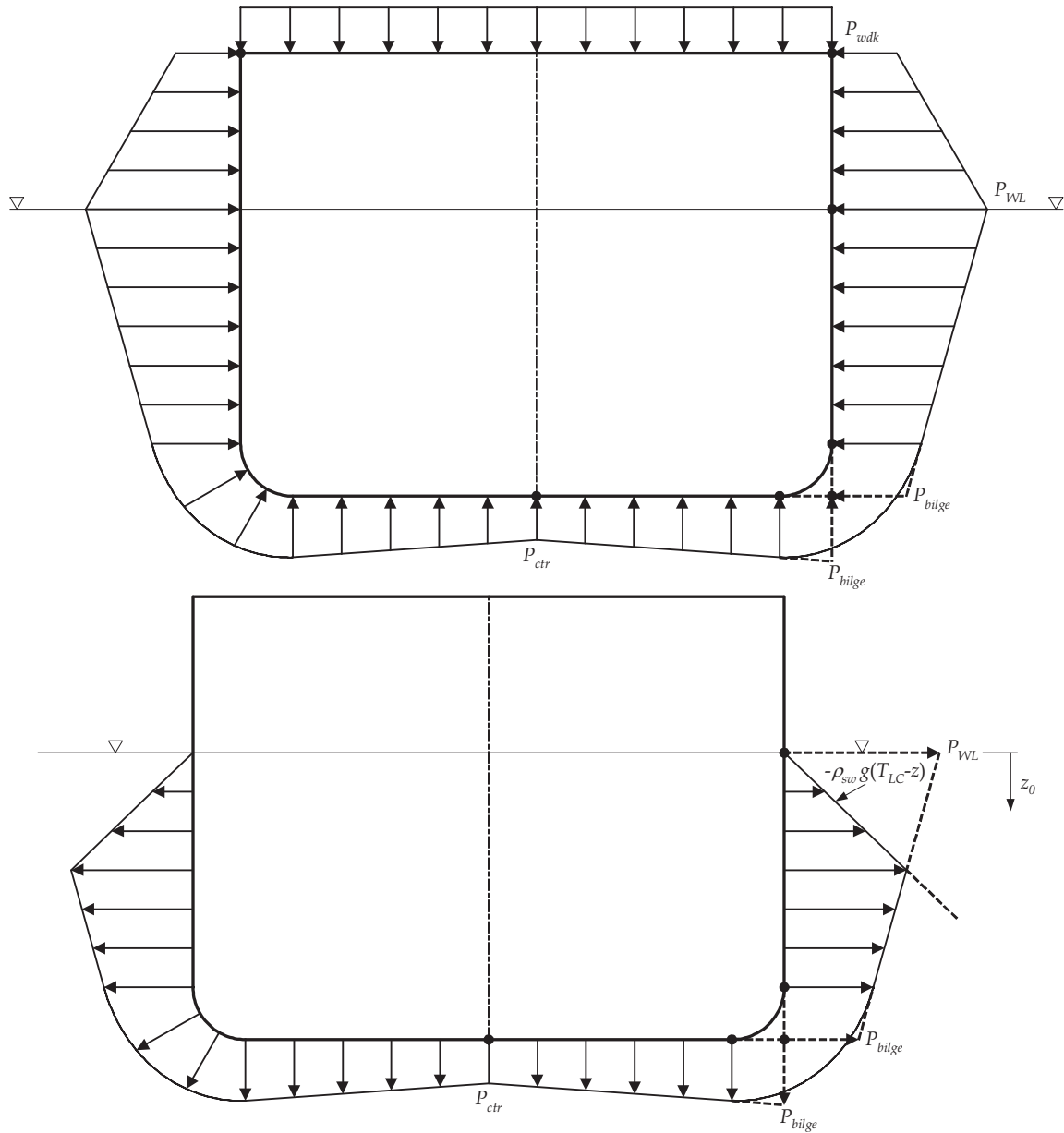

Fig. 7.6.2 Dynamic Wave Pressure for Beam and Oblique Sea Dynamic Load Cases

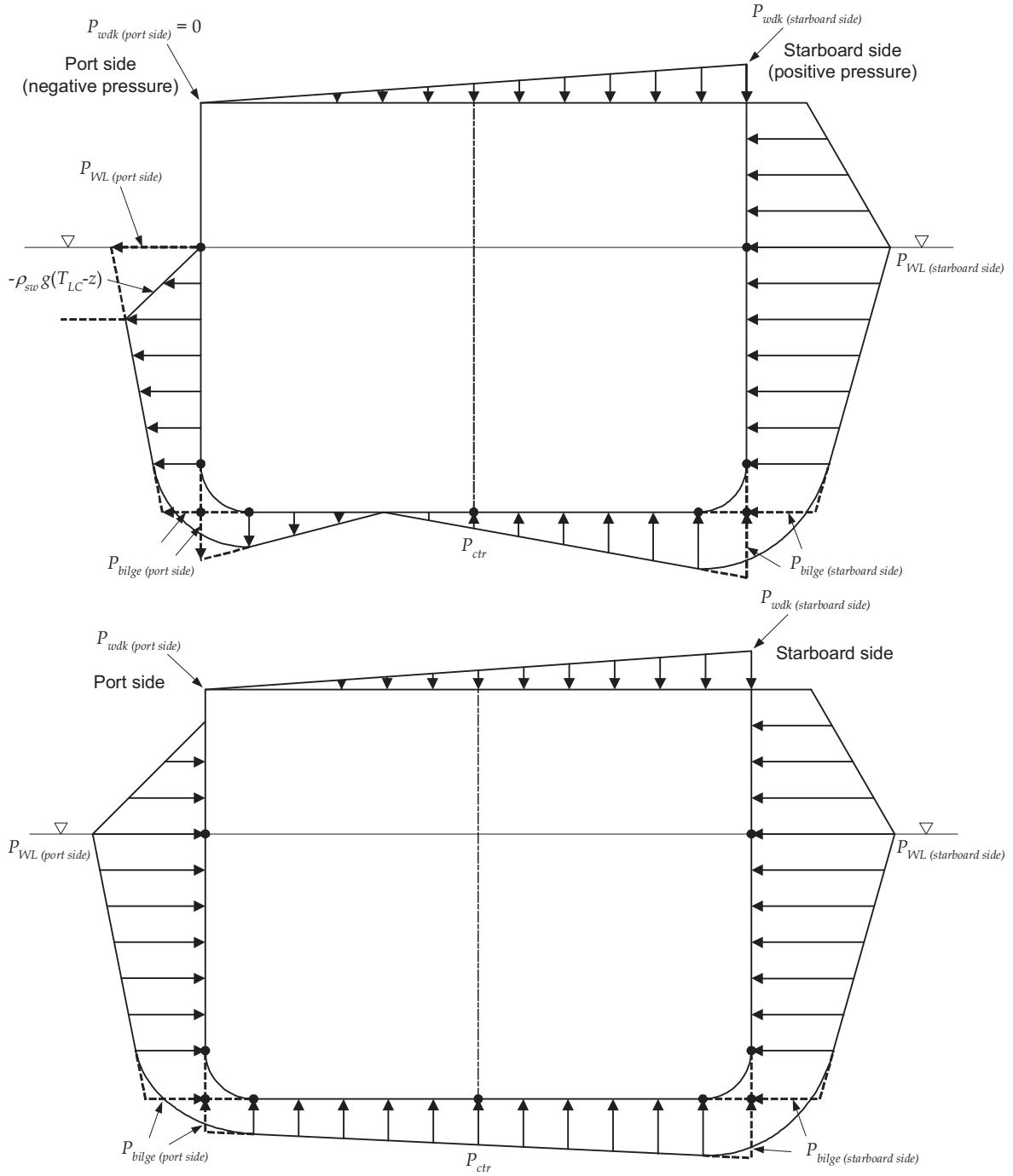
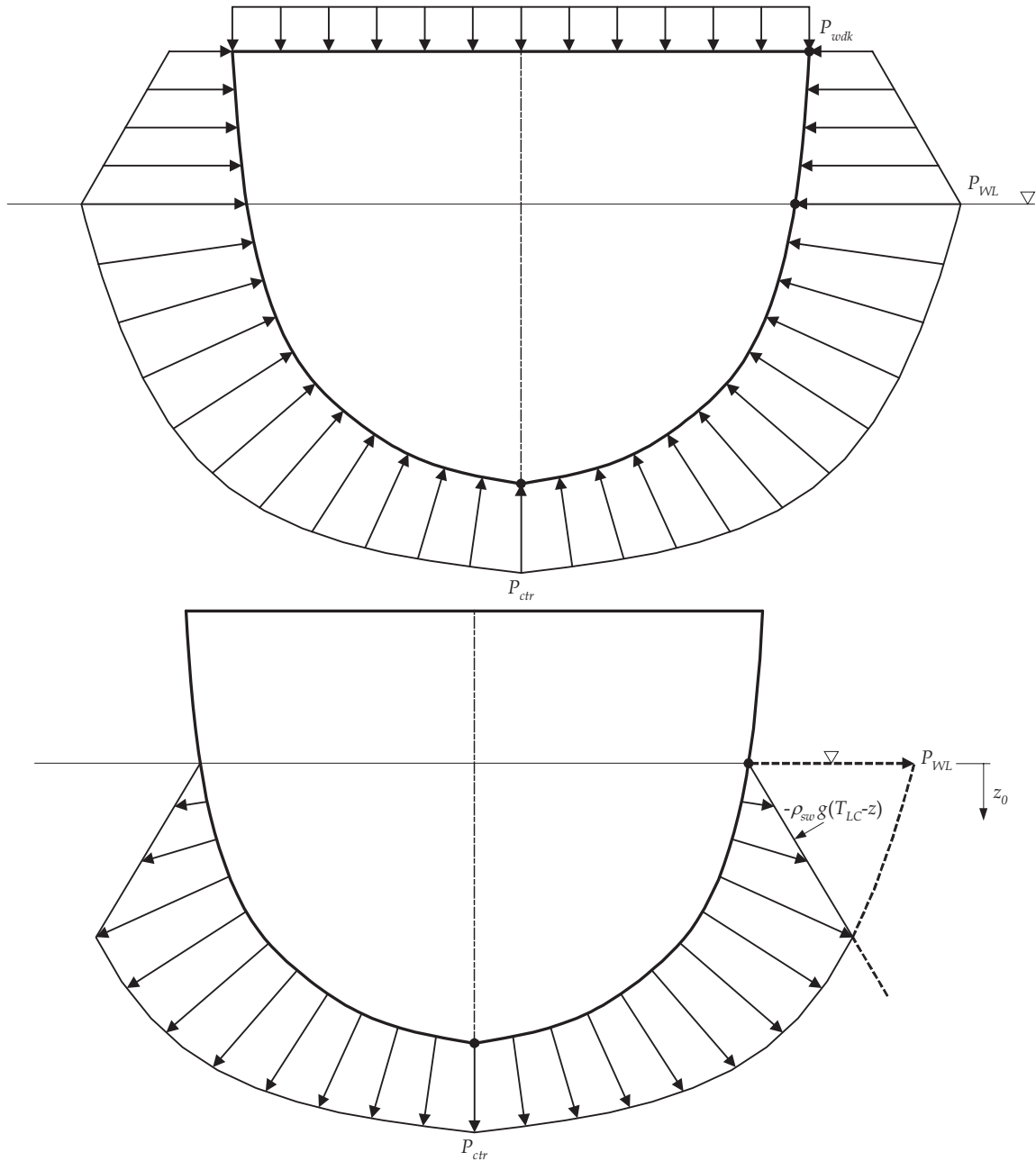

Fig. 7.6.3 Pressure Distribution for Wave Crest and Wave Trough for Forward and Aft



6.3.6 Green sea load for a considered dynamic load case

6.3.6.1 The simultaneously acting green sea load on the weather deck, $P_{wdk-dyn}$, for strength assessment is obtained by linear interpolation between P_{wdk-pt} and $P_{wdk-stb}$:

The green sea load at the port side, P_{wdk-pt} , is to be taken as the greater of

$$P_{wdk-pt} = f_{1-dk} (f_{WL} f_{op} P_{1-WL} - 10z_{dk-T}) \quad (kN/m^2)$$

$$P_{wdk-pt} = 0.8(f_{WL} P_{2-WL} - 10z_{dk-T}) \quad (kN/m^2)$$

P_{wdk-pt} is not to be taken as less than 34.3 kN/m^2 when $f_{WL} = 1.0$ and the ship's draught used in the design load case is greater or equal to $0.9T_{sc}$.

The green sea load at the starboard side, $P_{wdk-stb}$, is to be taken as the greater of

$$P_{wdk-stb} = f_{1-dk} (f_{WL} f_{op} P_{1-WL} - 10z_{dk-T}) \quad (kN/m^2)$$

$$P_{wdk-stb} = 0.8(f_{WL} P_{2-WL} - 10z_{dk-T}) \quad (kN/m^2)$$

$P_{wdk-stb}$ is not to be taken as less than 34.3 kN/m^2 when $f_{WL} = 1.0$ and the ship's draught used in the design load case is greater or equal to $0.9T_{sc}$.

P_{wdk-pt} and $P_{wdk-stb}$ are not to be taken as less than 0.

Where:

$$f_{1-dk} = 0.8 + \frac{L_{CSR-T}}{750}$$

$$f_{op} = 1.0 \quad \text{at and forward of } 0.2L_{CSR-T} \text{ from A.P.}$$

$$= 0.8 \quad \text{at and aft of A.P.}$$

intermediate values to be obtained by linear interpolation

P_{1-WL} : P_1 pressure at still waterline for considered draught, in kN/m^2 , see **3.5.2.1**

P_{2-WL} : P_2 pressure at still waterline for considered draught, in kN/m^2 , see **3.5.2.1**

f_{WL} : dynamic load combination factor for dynamic wave pressure at still waterline for considered dynamic load case, see **6.3.1.2**

z_{dk-T} : distance from the deck to the still waterline at the applicable draught for the loading condition being considered, in m

L_{CSR-T} : rule length, in m , as defined in **Section 4/1.1.1.1**

6.3.6.2 The simultaneously acting green sea load on the weather deck, $P_{wdk-dyn}$, for scantling requirements is to be taken as the greater of:

$$P_{wdk-dyn} = f_{1-dk} (f_{WL} f_{op} P_{1-WL} - 10z_{dk-T}) \quad (kN/m^2)$$

but is not to be taken as less than $34.3kN/m^2$ when $f_{WL} = 1.0$ and the ship's draught used in the design load case is greater or equal to $0.9T_{sc}$

$$P_{wdk-dyn} = 0.8f_{2-dk} (f_{WL} P_{2-WL} - 10z_{dk-T}) \quad (kN/m^2)$$

but is not to be taken as less than $34.3kN/m^2$ when $f_{WL} = 1.0$ and

$f_{2-dk} = 1.0$ and the ship's draught used in the design load case is greater or equal to $0.9T_{sc}$

$$P_{wdk-dyn} = 0$$

Where:

$$f_{1-dk} = 0.8 + \frac{L_{CSR-T}}{750}$$

$$f_{2-dk} = 0.5 + \frac{|y|}{B_{wdk}}$$

$$f_{op} = 1.0 \quad \text{at and forward of } 0.2L_{CSR-T} \text{ from A.P.}$$

$$= 0.8 \quad \text{at and aft of A.P.}$$

intermediate values to be obtained by linear interpolation

P_{1-WL} : P_1 pressure at still waterline for considered draught, in kN/m^2

P_{2-WL} : P_2 pressure at still waterline for considered draught, in kN/m^2

f_{WL} : dynamic load combination factor for dynamic wave pressure at still waterline for considered dynamic load case, see **6.3.1.2**

y : transverse coordinate, in m

z_{dk-T} : distance from the deck at side to the still waterline at the applicable draught for the loading condition being considered, in m

B_{wdk} : local breadth at the weather deck, in m

L_{CSR-T} : rule length, in m , as defined in **Section 4/1.1.1.1**

6.3.7 Dynamic tank pressure for a considered dynamic load case

6.3.7.1 The simultaneously acting dynamic tank pressure, P_{in-dyn} , for tanks in the cargo region, is to be taken as:

$$P_{in-dyn} = f_{\beta} (f_v P_{in-v} + f_t P_{in-t} + f_{lng} P_{in-lng}) \quad (kN/m^2)$$

Where:

P_{in-v} : envelope dynamic tank pressure due to vertical acceleration as defined in **3.5.4.1** with reference point z_0 taken as

(a) top of tank

(b) top of air pipe/overflow for ballast tanks designed for BWE by flow-through method

see **Fig. 7.6.4**, in kN/m^2

- P_{in-t} : envelope dynamic tank pressure due to transverse acceleration as defined in 3.5.4.2 with reference point y_0 taken as
 (a) tank top towards port side for $f_t > 0$
 (b) tank top towards starboard side for $f_t < 0$
 see Fig. 7.6.5, in kN/m^2
- P_{in-lng} : envelope dynamic tank pressure due to longitudinal acceleration as defined in 3.5.4.3 with reference point x_0 taken as
 (a) forward bulkhead for $f_{lng} > 0$
 (b) aft bulkhead of the tank for $f_{lng} < 0$
 see Fig. 7.6.6, in kN/m^2
- f_v : dynamic load combination factor for vertical acceleration for considered dynamic load case. f_v is to be taken as appropriate to the tank location, see 6.3.1.2
- f_t : dynamic load combination factor for transverse acceleration for considered dynamic load case, see 6.3.1.2
- f_{lng} : dynamic load combination factor for longitudinal acceleration for considered dynamic load case. f_{lng} is to be taken as most appropriate dependent on tank location, see 6.3.1.2
- f_β : heading correction factor, as defined in 6.3.1.1
- x_0 : longitudinal coordinate of reference point, in m
- y_0 : transverse coordinate of reference point, in m
- z_0 : vertical coordinate of reference point, in m

Note

1. For a non-parallel tank, y_0 should be selected from either forward or aft bulkhead corresponding to the reference point x_0 . If the longitudinal load combination factor $f_{lng} = 0$, y_0 should be selected from the bulkhead with the greater breadth.
2. The vertical, transverse and longitudinal acceleration is to be taken at the centre of gravity of the tank under consideration.

6.3.7.2 The simultaneously acting dynamic tank pressure for tanks outside the cargo region, P_{in-dyn} , is to be taken as:

$$P_{in-dyn} = f_\beta \left(f_{v-mid} P_{in-v} + |f_t P_{in-t}| + |f_{lng} P_{in-lng}| \right) \quad (kN/m^2)$$

Where:

- P_{in-v} : envelope dynamic wave pressure due to vertical acceleration as given in 3.5.4.1 with reference point z_0 taken as
 (a) top of tank
 (b) top of air pipe for ballast tanks design for BWE by flow through
 see Fig. 7.6.5, in kN/m^2
- P_{in-t} : envelope dynamic tank pressure due to transverse acceleration as given in 3.5.4.2 using $(y_0 - y)$ as extreme breadth of tank, in kN/m^2
- P_{in-lng} : envelope dynamic tank pressure due to longitudinal acceleration as given in 3.5.4.3 using $(x_0 - x)$ as extreme length of tank, in kN/m^2
- f_{v-mid} : dynamic load combination factor for vertical acceleration for considered dynamic load case, see 6.3.1.2
- f_t : dynamic load combination factor for transverse acceleration for considered dynamic load case, see 6.3.1.2
- f_{lng} : dynamic load combination factor for longitudinal acceleration for considered dynamic load case, see 6.3.1.2
- f_β : heading correction factor, as defined in 6.3.1.1
- x_0 : longitudinal coordinate of reference point, in m
- y_0 : transverse coordinate of reference point, in m
- z_0 : vertical coordinate of reference point, in m

Fig. 7.6.4 Dynamic Tank Pressure in Cargo Tank (Left) and Ballast Tank (Right) due to Positive and Negative Vertical Tank Acceleration

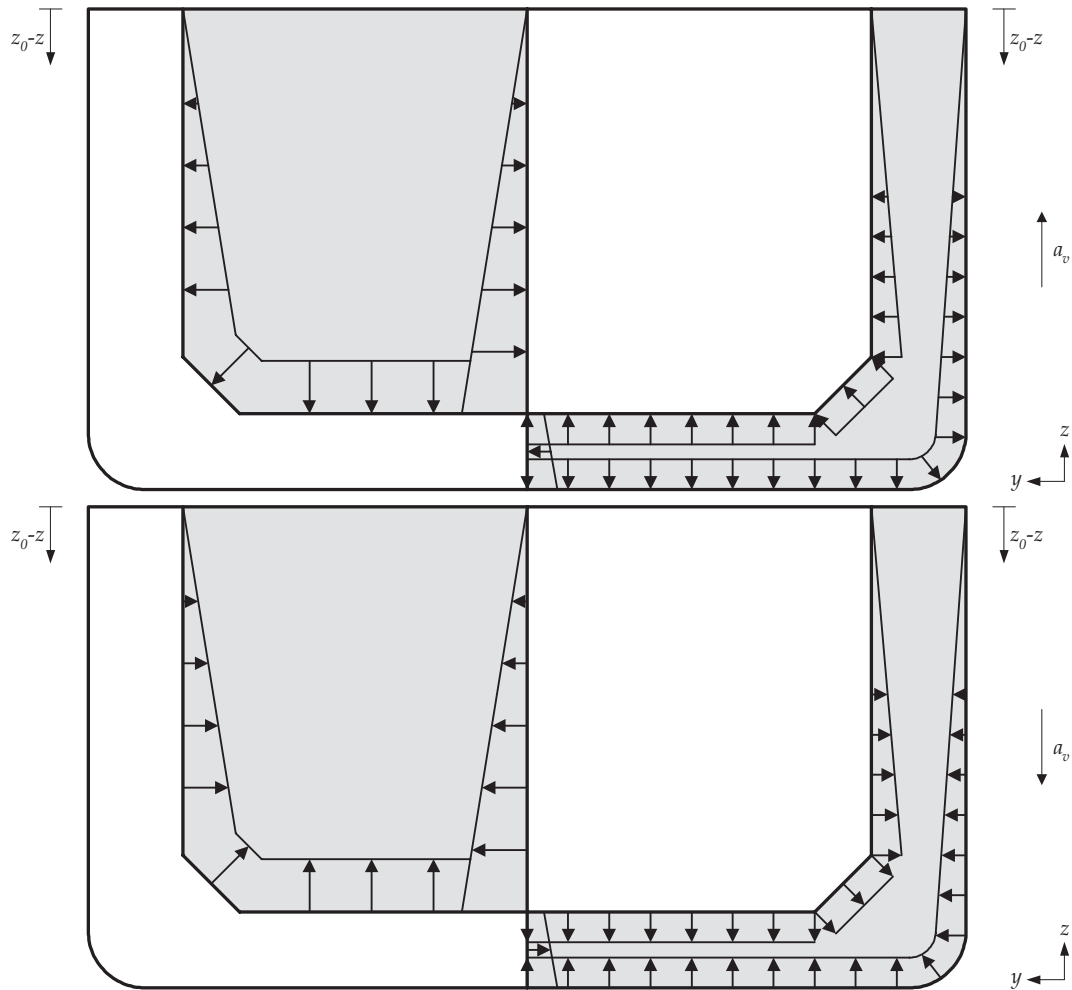

Note
 For ballast tank which is designed for ballast water exchange by flow-through method, reference point z_0 is to be taken as top of air pipe/overflow of the tank.

Fig. 7.6.5 Dynamic Tank Pressure in Cargo Tank (Left) and Ballast Tank (Right) due to Negative and Positive Transverse Tank Acceleration

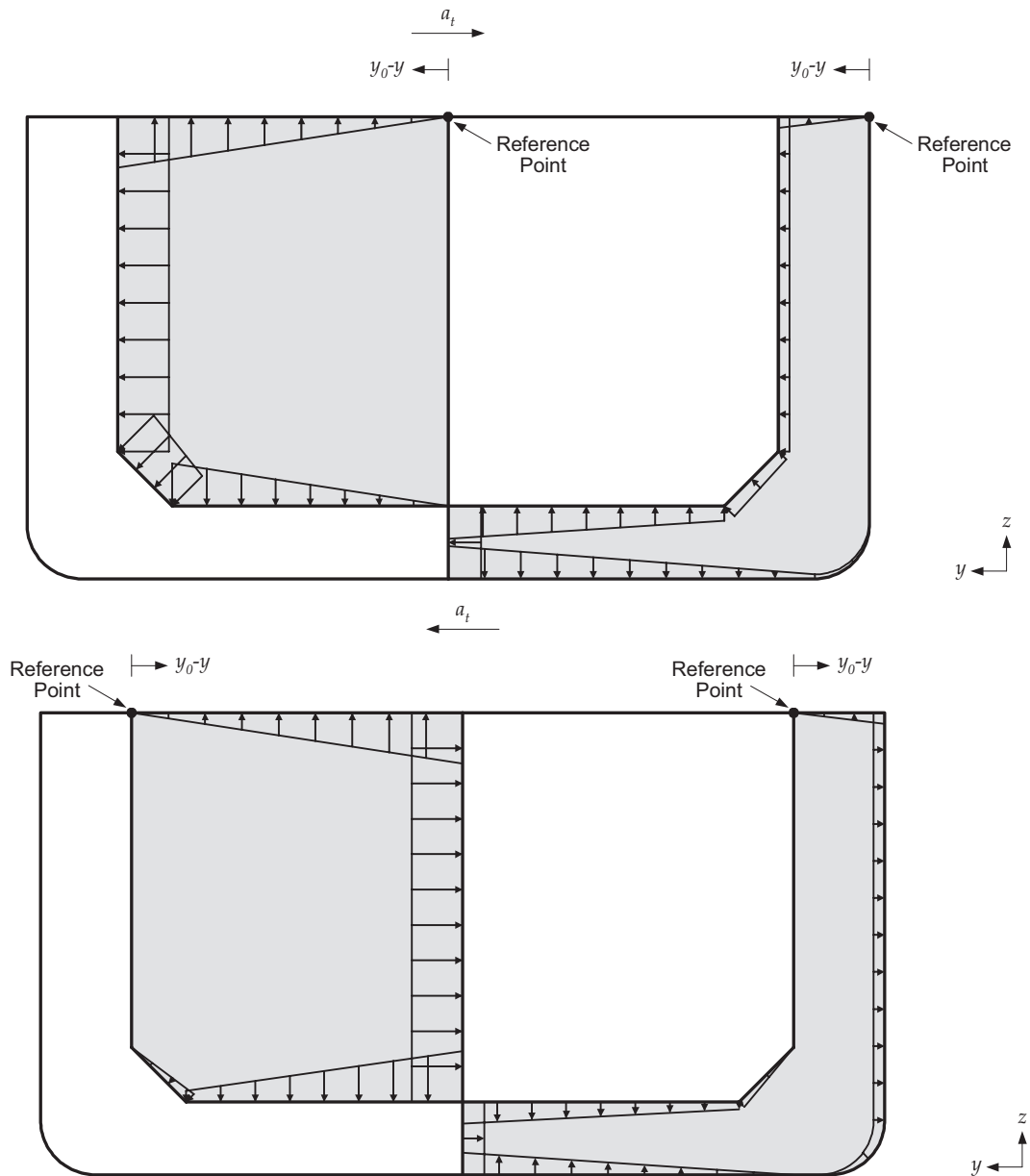
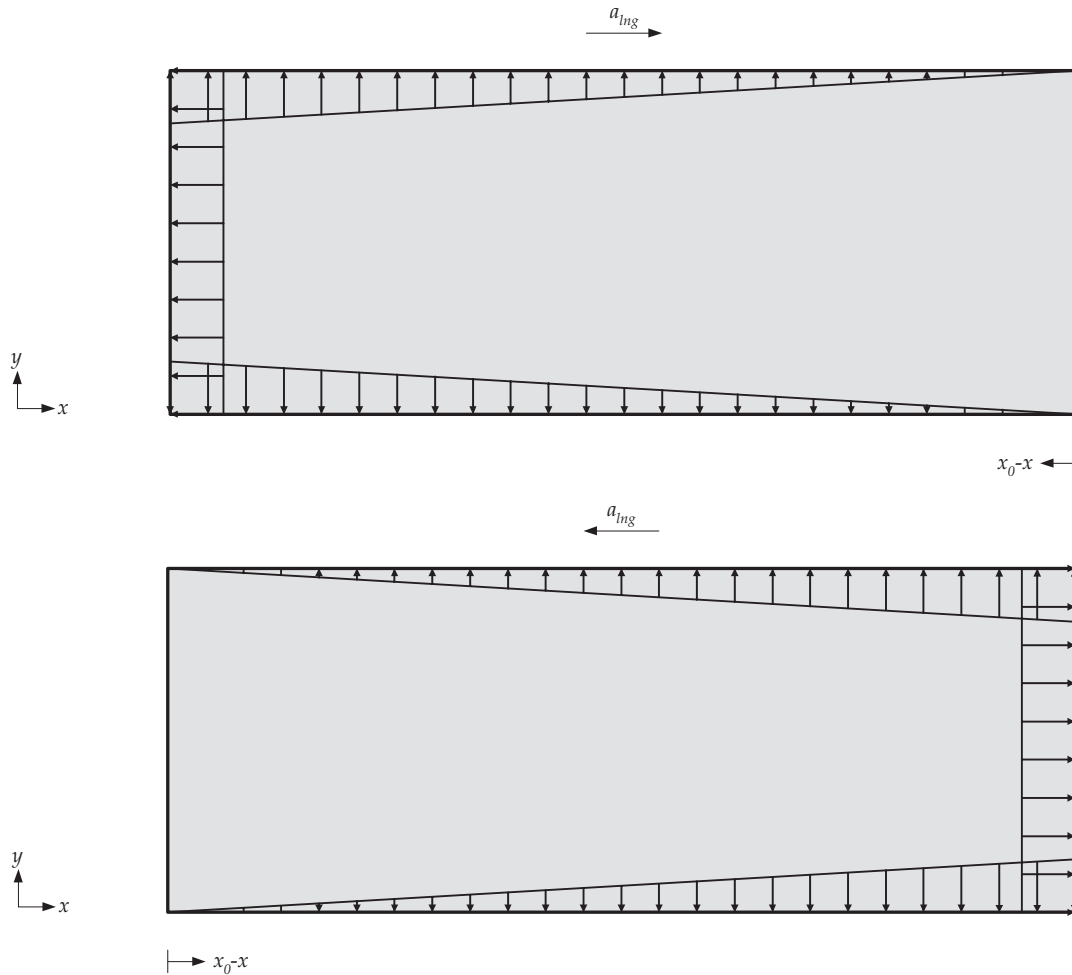

Fig. 7.6.6 Dynamic Tank Pressure in Tanks due to Positive and Negative Longitudinal Acceleration



6.3.8 Dynamic deck loads for a considered dynamic load case

6.3.8.1 The simultaneously acting dynamic deck load for uniformly distributed load, P_{dk-dyn} , on the enclosed upper deck, where a forecandle or poop is fitted, and also on all lower decks, is to be taken as:

$$P_{dk-dyn} = f_{\beta} f_{v-mid} P_{deck-dyn} \quad (kN/m^2)$$

Where:

$P_{deck-dyn}$: envelope dynamic deck pressure on decks, inner bottom and hatch covers, in kN/m^2 , as defined in **3.5.5.1**

f_{v-mid} : dynamic load combination factor for vertical acceleration for considered dynamic load case, see **6.3.1.2**

f_{β} : heading correction factor, as defined in **6.3.1.1**

6.3.8.2 The simultaneously acting dynamic vertical force for heavy units, F_{dk-dyn} , acting on supporting structures and securing systems for heavy units of cargo, equipment or structural components, is to be taken as:

$$F_{dk-dyn} = f_{\beta} f_{v-mid} F_v \quad (kN)$$

Where:

F_v : envelope vertical dynamic load from heavy units, in kN , as defined in **3.5.6**

f_{v-mid} : dynamic load combination factor for vertical acceleration for the considered dynamic load case, see **Table 7.6.2** and **Table 7.6.4** to **7.6.9**

f_{β} : heading correction factor, as defined in **6.3.1.1**

6.4 Dynamic Load Cases and Dynamic Load Combination Factors for Strength Assessment

6.4.1 General

6.4.1.1 For strength assessment (FEM) the dynamic load cases given in **Table 7.6.2** are to be applied in accordance with the requirements of **Appendix B** for Design Load Combination $S + D$. The simultaneously acting dynamic load cases are to be derived using the dynamic load combination factors given in **Table 7.6.2**.

Table 7.6.2 Dynamic Load Cases for Strength Assessment (by FEM)

Wave direction			Head sea				Beam sea		Oblique sea	
Max response			M_{ww} (Sagging)	M_{ww} (Hogging)	Q_{ww} (Sagging)	Q_{ww} (Hogging)	a_v		M_{wv-h} (Hogging)	
Dynamic Load Case			1	2	3	4	5a	5b	6a	6b
Global loads	M_{wv}	f_{mv}	-1.0	1.0	-1.0	1.0	0.0	0.0	0.4	0.4
	Q_{wv}	f_{qv}	1.0	-1.0	1.0	-1.0	0.0	0.0	0.0	0.0
	M_{wv-h}	f_{mh}	0.0	0.0	0.0	0.0	0.0	0.0	1.0	-1.0
Accelerations	a_v	f_v	0.5	-0.5	0.3	-0.3	1.0	1.0	-0.1	-0.1
	a_t	f_t	0.0	0.0	0.0	0.0	-0.6	0.6	0.0	0.0
	a_{ing}	f_{ing}	-0.6	0.6	-0.6	0.6	-0.5	-0.5	0.5	0.5
Dynamic wave pressure for port side	P_{WL}	f_{WL}	-0.3	0.3	0.1	-0.1	1.0	0.4	0.6	0.0
	P_{bilge}	f_{bilge}	-0.3	0.3	0.1	-0.1	1.0	0.4	0.4	0.0
	P_{ctr}	f_{ctr}	-0.7	0.7	0.3	-0.3	0.9	0.9	0.5	0.5
Dynamic wave pressure for starboard side	P_{WL}	f_{WL}	-0.3	0.3	0.1	-0.1	0.4	1.0	0.0	0.6
	P_{bilge}	f_{bilge}	-0.3	0.3	0.1	-0.1	0.4	1.0	0.0	0.4
	P_{ctr}	f_{ctr}	-0.7	0.7	0.3	-0.3	0.9	0.9	0.5	0.5

Where:

Symbols are as defined in 3.3, 6.3.5.1, Table 7.6.1 and below:

- f_{v-mid} dynamic load combination factor associated with the vertical acceleration of a centre cargo and ballast tank
- f_{v-pt} dynamic load combination factor associated with the vertical acceleration of a port cargo and side ballast tank
- f_{v-stb} dynamic load combination factor associated with the vertical acceleration of a starboard cargo and side ballast tank

Note:

1. Load parameters and locations to be used for the calculations are to be taken as specified in **Appendix B/2.4.1**

6.5 Dynamic Load Cases and Dynamic Load Combination for Scantling Requirements

6.5.1 General

6.5.1.1 For the scantling requirements the dynamic load cases are to be applied in accordance with the design load sets given in **Table 8.2.7** through **Table 8.2.9** for the design load combination $S + D$. The simultaneously acting dynamic load cases are to be derived using the dynamic load combination factors given in **Table 7.6.4** to **Table 7.6.9**.

6.5.1.2 The Dynamic Load Combination Factor (DLCF) table to be used depends on the longitudinal position being considered and is specified in **Fig. 7.6.7** and **Table 7.6.3**.

6.5.1.3 Each dynamic load case in the DLCF tables maximises one or more dynamic load components. The minimised dynamic load components are to be calculated by multiplying all the dynamic load combination factors for a dynamic load case by -1.0. The scantling requirements are to be evaluated for all maximised and minimised dynamic load cases.

6.5.1.4 Load parameters to be used for the calculations are to be taken as specified in **Table 8.2.8** and **Table 8.2.9**.

Fig. 7.6.7 Illustration of Structural Regions

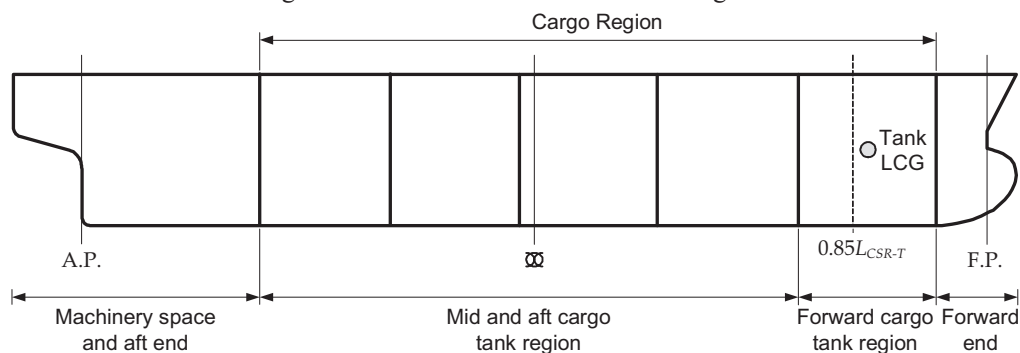

Table 7.6.3 Dynamic Load Combination Factor Tables used for Structural Region and Loading Condition

Structural region	Machinery Space and Aft End	Mid and aft cargo tank region	Forward cargo tank region	Forward end
Applicable for tanks and spaces	aft of aftmost cargo tank	where the tank LCG is aft of $0.85L_{CSR-T}$	where the tank LCG is at or forward of $0.85L_{CSR-T}$	forward of foremost bulkhead
Loaded DLCF	Table 7.6.8	Table 7.6.4	Table 7.6.6	Table 7.6.8
Ballast DLCF	Table 7.6.9	Table 7.6.5	Table 7.6.7	Table 7.6.9

Table 7.6.4 Dynamic Load Cases for Mid and Aft Cargo Tank Region for Loaded Condition

Wave direction			Head Sea			Oblique Sea				Beam Sea			
Max response			M_{wv}	a_v	a_{lng}	M_{wv-h}		a_t		P_{ctr}		P_{WL}	
Dynamic Load Case			1	2	3	4a	4b	5a	5b	6a	6b	7a	7b
Global loads	M_{wv}	f_{mv}	1.0	-1.0	0.5	-0.2	-0.2	-0.1	-0.1	-0.2	-0.2	-0.3	-0.3
	M_{wv-h}	f_{mh}	0.0	0.0	0.0	1.0	-1.0	-0.1	0.1	0.0	0.0	0.0	0.0
Accelerations	a_{v-mid}	f_{v-mid}	-0.2	0.5	-0.4	-0.1	-0.1	0.5	0.5	1.0	1.0	1.0	1.0
	a_{v-pt}	f_{v-pt}	-0.2	0.5	-0.4	-0.1	-0.1	0.2	0.6	0.8	1.0	0.8	1.0
	a_{v-stb}	f_{v-stb}	-0.2	0.5	-0.4	-0.1	-0.1	0.6	0.2	1.0	0.8	1.0	0.8
	a_t	f_t	0.0	0.0	0.0	0.0	0.0	1.0	-1.0	0.5	-0.5	0.6	-0.6
	$a_{lng-mid}$	$f_{lng-mid}$	0.3	-0.6	1.0	-0.3	-0.3	-0.1	-0.1	-0.5	-0.5	-0.6	-0.6
	a_{lng-pt}	f_{lng-pt}	0.3	-0.6	1.0	-0.4	-0.2	-0.1	-0.1	-0.5	-0.5	-0.6	-0.6
	$a_{lng-stb}$	$f_{lng-stb}$	0.3	-0.6	1.0	-0.2	-0.4	-0.1	-0.1	-0.5	-0.5	-0.6	-0.6
	$a_{lng-ctr}$	$f_{lng-ctr}$	0.3	-0.6	1.0	-0.3	-0.3	-0.1	-0.1	-0.5	-0.5	-0.6	-0.6
Dynamic wave pressure for starboard side	P_{ctr}	f_{ctr}	0.7	-0.6	0.2	-0.3	-0.3	0.5	0.5	1.0	1.0	0.9	0.9
	P_{bilge}	f_{bilge}	0.3	-0.2	0.1	-0.4	-0.1	0.8	-0.3	0.9	0.4	1.0	0.4
	P_{WL}	f_{WL}	0.3	-0.3	0.1	-0.6	-0.1	0.5	-0.2	0.8	0.4	1.0	0.4
Dynamic wave pressure for port side	P_{ctr}	f_{ctr}	0.7	-0.6	0.2	-0.3	-0.3	0.5	0.5	1.0	1.0	0.9	0.9
	P_{bilge}	f_{bilge}	0.3	-0.2	0.1	-0.1	-0.4	-0.3	0.8	0.4	0.9	0.4	1.0
	P_{WL}	f_{WL}	0.3	-0.3	0.1	-0.1	-0.6	-0.2	0.5	0.4	0.8	0.4	1.0

Where: Symbols are as defined in 3.3, 3.4.2, 6.3.5.1 and Table 7.6.1 and Table 7.6.2 and below

- a_{v-pt} vertical acceleration for port tank, in m/s^2
- a_{v-stb} vertical acceleration for starboard tank, in m/s^2
- $a_{lng-mid}$ longitudinal acceleration for centre tank, in m/s^2
- a_{lng-pt} longitudinal acceleration for port tank, in m/s^2
- $a_{lng-stb}$ longitudinal acceleration for starboard tank, in m/s^2
- $a_{lng-ctr}$ longitudinal acceleration for centre double bottom ballast tank, in m/s^2
- f_{lng-pt} dynamic load combination factor associated with the longitudinal acceleration of a port side cargo or ballast tank
- $f_{lng-stb}$ dynamic load combination factor associated with the longitudinal acceleration of a starboard side cargo or ballast tank
- $f_{lng-ctr}$ dynamic load combination factor associated with the longitudinal acceleration of a centre double bottom ballast tank
- $f_{lng-mid}$ dynamic load combination factor associated with the longitudinal acceleration of a centre tank

Table 7.6.5 Dynamic Load Cases for Mid and Aft Cargo Tank Region for Ballast Condition

Wave direction			Head Sea			Oblique Sea		Beam Sea					
Max response			M_{WV}	a_v	a_{lng}	M_{WV-h}		a_t		P_{ctr}		P_{WL}	
Dynamic Load Case			1	2	3	4a	4b	5a	5b	6a	6b	7a	7b
Global loads	M_{WV}	f_{mv}	1.0	-1.0	0.4	-0.4	-0.4	-0.1	-0.1	-0.2	-0.2	-0.2	-0.2
	M_{WV-h}	f_{mh}	0.0	0.0	0.0	1.0	-1.0	0.1	-0.1	-0.1	0.1	-0.2	0.2
Accelerations	a_{v-mid}	f_{v-mid}	-0.1	0.4	-0.2	0.1	0.1	0.5	0.5	1.0	1.0	1.0	1.0
	a_{v-pt}	f_{v-pt}	-0.1	0.4	-0.2	0.1	0.1	0.1	0.8	0.7	1.0	0.6	1.0
	a_{v-stb}	f_{v-stb}	-0.1	0.4	-0.2	0.1	0.1	0.8	0.1	1.0	0.7	1.0	0.6
	a_t	f_t	0.0	0.0	0.0	0.0	0.0	1.0	-1.0	0.8	-0.8	0.6	-0.6
	$a_{lng-mid}$	$f_{lng-mid}$	0.2	-0.1	1.0	-0.6	-0.6	0.0	0.0	-0.2	-0.2	-0.1	-0.1
	a_{lng-pt}	f_{lng-pt}	0.2	-0.1	1.0	-0.6	-0.4	0.0	0.0	-0.2	-0.2	-0.1	-0.1
	$a_{lng-stb}$	$f_{lng-stb}$	0.2	-0.1	1.0	-0.4	-0.6	0.0	0.0	-0.2	-0.2	-0.1	-0.1
	$a_{lng-ctr}$	$f_{lng-ctr}$	0.2	-0.1	1.0	-0.4	-0.4	0.0	0.0	-0.2	-0.2	-0.1	-0.1
Dynamic wave pressure for starboard side	P_{ctr}	f_{ctr}	1.0	-0.8	0.3	-0.5	-0.5	0.3	0.3	0.8	0.8	0.4	0.4
	P_{bilge}	f_{bilge}	0.3	-0.2	0.1	-0.4	0.0	0.9	-0.4	0.9	0.3	0.9	0.2
	P_{WL}	f_{WL}	0.3	-0.2	0.1	-0.6	0.0	0.7	-0.4	0.9	0.2	1.0	0.2
Dynamic wave pressure for port side	P_{ctr}	f_{ctr}	1.0	-0.8	0.3	-0.5	-0.5	0.3	0.3	0.8	0.8	0.4	0.4
	P_{bilge}	f_{bilge}	0.3	-0.2	0.1	0.0	-0.4	-0.4	0.9	0.3	0.9	0.2	0.9
	P_{WL}	f_{WL}	0.3	-0.2	0.1	0.0	-0.6	-0.4	0.7	0.2	0.9	0.2	1.0

Where:

Symbols are as defined in 3.3, 3.4.2, 6.3.5.1 and Table 7.6.1, Table 7.6.2 and Table 7.6.4

Table 7.6.6 Dynamic Load Cases for Forward Cargo Tank Region for Loaded Condition

Wave direction			Head Sea		Oblique Sea							Beam				
Max response			a_v	a_{lng}	a_{lng}		P_{ctr}		P_{bilge}		P_{WL}		a_v		a_t	
Dynamic Load Case			1	2	3a	3b	4a	4b	5a	5b	6a	6b	7a	7b	8a	8b
Global loads	M_{WV}	f_{mv}	-0.7	0.9	0.3	0.3	-0.6	-0.6	-0.3	-0.3	-0.4	-0.4	-0.4	-0.4	-0.1	-0.1
	M_{WV-h}	f_{mh}	0.0	0.0	-0.2	0.2	0.2	-0.2	-0.1	0.1	0.2	-0.2	-0.1	0.1	-0.5	0.5
Accelerations	a_{v-mid}	f_{v-mid}	0.7	-0.6	-0.6	-0.6	0.7	0.7	0.9	0.9	0.7	0.7	1.0	1.0	0.4	0.4
	a_{v-pt}	f_{v-pt}	0.7	-0.6	-0.6	-0.6	0.7	0.7	0.9	1.0	0.7	0.7	0.9	1.0	0.3	0.6
	a_{v-stb}	f_{v-stb}	0.7	-0.6	-0.6	-0.6	0.7	0.7	1.0	0.9	0.7	0.7	1.0	0.9	0.6	0.3
	a_t	f_t	0.0	0.0	-0.4	0.4	0.1	-0.1	0.7	-0.7	0.5	-0.5	0.6	-0.6	1.0	-1.0
	$a_{lng-mid}$	$f_{lng-mid}$	-0.8	1.0	0.8	0.8	-1.0	-1.0	-0.5	-0.5	-1.0	-1.0	-0.5	-0.5	-0.1	-0.1
	a_{lng-pt}	f_{lng-pt}	-0.8	1.0	1.0	0.6	-1.0	-0.9	-0.5	-0.5	-1.0	-0.7	-0.5	-0.5	-0.1	-0.1
	$a_{lng-stb}$	$f_{lng-stb}$	-0.8	1.0	0.6	1.0	-0.9	-1.0	-0.5	-0.5	-0.7	-1.0	-0.5	-0.5	-0.1	-0.1
	$a_{lng-ctr}$	$f_{lng-ctr}$	-0.8	1.0	0.8	0.8	-1.0	-1.0	-0.5	-0.5	-1.0	-1.0	-0.5	-0.5	-0.1	-0.1
Dynamic wave pressure on starboard side	P_{ctr}	f_{ctr}	1.0	-0.9	-0.4	-0.4	1.0	1.0	0.8	0.8	0.5	0.5	0.8	0.8	0.4	0.4
	P_{bilge}	f_{bilge}	0.6	-0.7	-0.6	-0.2	0.9	0.6	1.0	0.5	0.7	0.3	1.0	0.5	0.8	-0.1
	P_{WL}	f_{WL}	0.3	-0.5	-0.9	-0.2	0.8	0.4	0.9	0.4	1.0	0.2	0.9	0.4	0.6	-0.2
Dynamic wave pressure on port side	P_{ctr}	f_{ctr}	1.0	-0.9	-0.4	-0.4	1.0	1.0	0.8	0.8	0.5	0.5	0.8	0.8	0.4	0.4
	P_{bilge}	f_{bilge}	0.6	-0.7	-0.2	-0.6	0.6	0.9	0.5	1.0	0.3	0.7	0.5	1.0	-0.1	0.8
	P_{WL}	f_{WL}	0.3	-0.5	-0.2	-0.9	0.4	0.8	0.4	0.9	0.2	1.0	0.4	0.9	-0.2	0.6

Where:

Symbols are as defined in 3.3, 3.4.2, 6.3.5.1 and Table 7.6.1, Table 7.6.2 and Table 7.6.4

Table 7.6.7 Dynamic Load Cases for Forward Cargo Tank Region for Ballast Condition

Wave direction			Head Sea		Oblique Sea								Beam Sea			
Max response			a_v	a_{lng}	a_{lng}		P_{ctr}		P_{bilge}		P_{WL}		a_v		a_t	
Dynamic Load Case			1	2	3a	3b	4a	4b	5a	5b	6a	6b	7a	7b	8a	8b
Global loads	M_{wv}	f_{mv}	-0.8	0.9	0.7	0.7	-1.0	-1.0	-0.2	-0.2	-0.3	-0.3	-0.1	-0.1	-0.1	-0.1
	M_{wv-h}	f_{mh}	0.0	0.0	-0.4	0.4	0.0	0.0	-0.5	0.5	0.3	-0.3	-0.4	0.4	-0.4	0.4
Accelerations	a_{v-mid}	f_{v-mid}	0.7	-0.6	-0.7	-0.7	0.4	0.4	0.6	0.6	0.9	0.9	1.0	1.0	0.4	0.4
	a_{v-pt}	f_{v-pt}	0.7	-0.6	-0.7	-0.7	0.4	0.4	0.3	0.8	0.7	0.7	0.5	1.0	0.0	0.7
	a_{v-stb}	f_{v-stb}	0.7	-0.6	-0.7	-0.7	0.4	0.4	0.8	0.3	0.7	0.7	1.0	0.5	0.7	0.0
	a_t	f_t	0.0	0.0	0.0	0.0	0.0	0.0	0.9	-0.9	0.2	-0.2	0.7	-0.7	1.0	-1.0
	$a_{lng-mid}$	$f_{lng-mid}$	-0.9	1.0	1.0	1.0	-0.6	-0.6	-0.3	-0.3	-0.9	-0.9	0.0	0.0	0.0	0.0
	a_{lng-pt}	f_{lng-pt}	-0.9	1.0	1.0	1.0	-0.6	-0.6	-0.5	0.2	-0.9	-0.6	0.0	0.0	0.0	0.0
	$a_{lng-stb}$	$f_{lng-stb}$	-0.9	1.0	1.0	1.0	-0.6	-0.6	0.2	-0.5	-0.6	-0.9	0.0	0.0	0.0	0.0
	$a_{lng-ctr}$	$f_{lng-ctr}$	-0.9	1.0	1.0	1.0	-0.6	-0.6	-0.3	-0.3	-0.9	-0.9	0.0	0.0	0.0	0.0
Dynamic wave pressure on starboard side	P_{ctr}	f_{ctr}	1.0	-0.7	-0.9	-0.9	1.0	1.0	0.6	0.6	0.6	0.6	0.4	0.4	0.2	0.2
	P_{bilge}	f_{bilge}	0.5	-0.4	-0.7	-0.3	0.6	0.6	1.0	-0.3	0.9	0.2	0.8	0.2	0.7	-0.3
	P_{WL}	f_{WL}	0.3	-0.2	-0.6	-0.1	0.4	0.4	0.9	-0.3	1.0	0.1	0.8	0.2	0.7	-0.4
Dynamic wave pressure on port side	P_{ctr}	f_{ctr}	1.0	-0.7	-0.9	-0.9	1.0	1.0	0.6	0.6	0.6	0.6	0.4	0.4	0.2	0.2
	P_{bilge}	f_{bilge}	0.5	-0.4	-0.3	-0.7	0.6	0.6	-0.3	1.0	0.2	0.9	0.2	0.8	-0.3	0.7
	P_{WL}	f_{WL}	0.3	-0.2	-0.1	-0.6	0.4	0.4	-0.3	0.9	0.1	1.0	0.2	0.8	-0.4	0.7

Where:

Symbols are as defined in 3.3, 3.4.2, 6.3.5.1 and Table 7.6.1, Table 7.6.2 and Table 7.6.4

Table 7.6.8 Dynamic Load Cases for Spaces Outside the Cargo Tank Region for Loaded Condition

Ship location			Machinery Space and Aft End								Forward End			
Wave direction			Following Sea	Oblique Sea			Beam Sea			Beam Sea				
Max response			P_{ctr}	P_{WL}		a_v		a_t		a_v		a_t		
Dynamic Load Case			1	2a	2b	3a	3b	4a	4b	5a	5b	6a	6b	
Global Load	M_{wv}	f_{mv}	-1.0	-0.7	-0.7	-0.4	-0.4	-0.1	-0.1	-	-	-	-	
Accelerations	a_{v-mid}	f_{v-mid}	0.6	0.9	0.9	1.0	1.0	0.3	0.3	1.0	1.0	0.3	0.3	
	a_{v-pt}	f_{v-pt}	0.6	-	0.9	-	1.0	-	0.4	-	1.0	-	0.3	
	a_{v-stb}	f_{v-stb}	0.6	0.9	-	1.0	-	0.4	-	1.0	-	0.3	-	
	a_t	f_t	0.0	0.2	-0.2	0.5	-0.5	1.0	-1.0	0.7	-0.7	1.0	-1.0	
	a_{lng}	f_{lng}	0.8	0.7	0.7	0.6	0.6	-0.1	-0.1	-0.7	-0.7	-0.1	-0.1	
Dynamic wave pressure on starboard side	P_{ctr}	f_{ctr}	1.0	0.8	0.8	0.7	0.7	0.2	0.2	1.0	1.0	0.2	0.2	
	P_{WL}	f_{WL}	0.5	1.0	0.2	0.8	0.3	0.5	-0.3	1.0	0.8	0.2	0.0	
Dynamic wave pressure on port side	P_{ctr}	f_{ctr}	1.0	0.8	0.8	0.7	0.7	0.2	0.2	1.0	1.0	0.2	0.2	
	P_{WL}	f_{WL}	0.5	0.2	1.0	0.3	0.8	-0.3	0.5	0.8	1.0	0.0	0.2	

Where:

Symbols are as defined in 3.3, 6.3.5.1 and Table 7.6.1, Table 7.6.2 and Table 7.6.4

Table 7.6.9 Dynamic Load Cases for Spaces Outside the Cargo Tank Region for Ballast Condition

Ship location			Machinery Space and Aft End							Forward End			
Wave direction			Following Sea	Oblique Sea		Beam Sea				Beam Sea			
Max response			P_{ctr}	P_{WL}		a_v		a_t		a_v		a_t	
Dynamic Load Case			1	2a	2b	3a	3b	4a	4b	5a	5b	6a	6b
Global Load	M_{wv}	f_{mv}	-1.0	-0.3	-0.3	0.2	0.2	0.1	0.1	-	-	-	-
Accelerations	a_{v-mid}	f_{v-mid}	0.6	0.9	0.9	1.0	1.0	0.3	0.3	1.0	1.0	0.3	0.3
	a_{v-pt}	f_{v-pt}	0.6	-	0.9	-	1.0	-	0.5	-	1.0	-	0.5
	a_{v-stb}	f_{v-stb}	0.6	0.9	-	1.0	-	0.5	-	1.0	-	0.5	-
	a_t	f_t	0.0	0.1	-0.1	0.6	-0.6	1.0	-1.0	0.7	-0.7	1.0	-1.0
	a_{lng}	f_{lng}	0.7	0.8	0.8	0.2	0.2	0.0	0.0	-0.3	-0.3	0.0	0.0
Dynamic wave pressure on starboard side	P_{ctr}	f_{ctr}	1.0	0.7	0.7	0.5	0.5	0.1	0.1	0.6	0.6	0.1	0.1
	P_{WL}	f_{WL}	0.8	1.0	0.3	0.6	0.1	0.4	-0.3	0.7	0.3	0.3	-0.1
Dynamic wave pressure on port side	P_{ctr}	f_{ctr}	1.0	0.7	0.7	0.5	0.5	0.1	0.1	0.6	0.6	0.1	0.1
	P_{WL}	f_{WL}	0.8	0.3	1.0	0.1	0.6	-0.3	0.4	0.3	0.7	-0.1	0.3

Where:

Symbols are as defined in 3.3, 6.3.5.1 and Table 7.6.1, Table 7.6.2 and Table 7.6.4

Section 8 SCANTLING REQUIREMENTS

1. Longitudinal Strength

1.1 Loading Guidance

1.1.1 General

1.1.1.1 All ships are to be provided with loading guidance information containing sufficient information to enable the master of the ship to maintain the ship within the stipulated operational limitations. The loading guidance information is to include an approved Loading Manual and Loading Computer System complying with the requirements given in **1.1.2** and **1.1.3** respectively.

1.1.1.2 The loading guidance information is to be based on the final data of the ship.

1.1.1.3 Modifications resulting in changes to the main data of the ship (lightship weight, buoyancy distribution, tank volumes or usage, etc), require the Loading Manual to be updated and re-approved, and subsequently the Loading Computer System to be updated and re-approved. However, new loading guidance need not be re-submitted provided that the resulting draughts, still water bending moments and shear forces do not differ from the originally approved data by more than 2%.

1.1.1.4 The loading guidance is to be prepared in a language understood by the users. If this language is not English, a translation into English shall be included. When applicable a document translating the language of the input and output data for the Loading Computer System into English is to be provided.

1.1.1.5 The loading guidance information is to include the following statement, to ensure the crew are aware of the operational limitations for minimum draught forward:

The scantlings are approved for a minimum draught forward, at F.P. In sea conditions where slamming is likely to occur, the forward draught is not to be less than the following:

- (a)...m with double bottom ballast tanks No(s)... filled, or
- (b)...m with double bottom ballast tanks No(s)... empty

1.1.2 Loading Manual

1.1.2.1 The Loading Manual is a document that:

- (a) describes the loading conditions on which the design and approval of the ship has been based for seagoing- and harbour/sheltered water operation
- (b) describes the results of the calculations of still water bending moments, shear forces and where applicable, limitations due to torsional and lateral loads
- (c) describes relevant operational limitations as given in **1.1.2.7**.

1.1.2.2 The following loading conditions and design loading and ballast conditions upon which the approval of the hull scantlings is based are, as a minimum, to be included in the Loading Manual:

- (a) Seagoing conditions including both departure and arrival conditions
 - homogeneous loading conditions including a condition at the scantling draft (homogeneous loading conditions shall not include filling of dry and clean ballast tanks at departure condition)
 - a normal ballast condition where:
 - * the ballast tanks may be full, partially full or empty. Where partially full options are exercised, the conditions in **1.1.2.5** are to be complied with
 - * all cargo tanks are to be empty including cargo tanks suitable for the carriage of water ballast at sea
 - * the propeller is to be fully immersed, and
 - * the trim is to be by the stern and is not to exceed $0.015L_{CSR-T}$, where L_{CSR-T} is as defined in **Section 4/1.1.1**
 - a heavy ballast condition where:
 - * the draught at the forward perpendicular is not to be less than that for the normal ballast condition
 - * ballast tanks in the cargo tank region or aft of the cargo tank region may be full, partially full or empty. Where the partially full options are exercised, the conditions in **1.1.2.5** are to be complied with

- * the fore peak water ballast tank is to be full. If upper and lower fore peak water ballast tanks are fitted, the lower is required to be full. The upper fore peak tank may be full, partially full or empty. If upper and lower fore peak tanks are fitted and only one of them is designated as water ballast tank, the other may be empty.
 - * all cargo tanks are to be empty including cargo tanks suitable for the carriage of water ballast at sea
 - * the propeller is to be fully immersed
 - * the trim is to be by the stern and is not to exceed $0.015L_{CSR-T}$, where L_{CSR-T} is as defined in **Section 4/1.1.1**
- any specified non-uniform distribution of loading
 - conditions with high density cargo including the maximum design cargo density, when applicable
 - mid-voyage conditions relating to tank cleaning or other operations where these differ significantly from the ballast conditions
 - conditions covering ballast water exchange procedures with the calculations of the intermediate condition just before and just after ballasting and/or deballasting any ballast tank
- (b) Harbour/sheltered water conditions
- conditions representing typical complete loading and unloading operations
 - docking condition afloat
 - propeller inspection afloat condition, in which the propeller shaft centre line is at least $D_{prop}/4$ above the waterline in way of the propeller, where D_{prop} is the propeller diameter
- (c) Additional design conditions
- a design ballast condition in which all segregated ballast tanks in the cargo tank region are full and all other tanks are empty including fuel oil and fresh water tanks.

Guidance Note

The design condition specified in (c) is for assessment of hull strength and is not intended for ship operation. This condition will also be covered by the **IMO 73/78 SBT** condition provided the corresponding condition in the Loading Manual only includes ballast in segregated ballast tanks in the cargo tank region.

1.1.2.3 The calculation for the departure conditions are to be based on full tanks according to the applicable stability regulations for filling of tanks; note bunker tanks are not to be taken less than 95% full and other consumables are to be taken at 100% capacity. Arrival conditions are to be based on 10% of the maximum capacity of bunker, fresh water and stores.

1.1.2.4 Where the amount and disposition consumables at any intermediate stage of the voyage are considered more severe than of those described in **1.1.2.3**, calculations for such intermediate conditions are also to be submitted for approval.

1.1.2.5 Ballast loading conditions involving partially filled peak and/or other ballast tanks in any departure, arrival or intermediate condition are not permitted to be used as design loading conditions unless, for all filling levels between empty and full, the resulting stress levels are within the stress and buckling acceptance criteria. For design purposes this criteria will be satisfied if the stress levels are within the stress and buckling acceptance criteria for loading conditions with the appropriate tanks full, empty and partially filled at intended level in any departure, arrival or intermediate condition. The corresponding full, empty and partially filled tank conditions are to be considered as design conditions for calculation of the still water bending moment and shear force, but these do not need to comply with propeller immersion and trim requirements as specified in **1.1.2.2(a)**. Where multiple ballast tanks are intended to be partially filled, all combinations of full, empty or partially filled at intended levels for those tanks are to be investigated. These requirements are not applicable to ballast water exchange using the sequential method.

1.1.2.6 In cargo loading conditions, the requirements for partially filled ballast tanks as specified in **1.1.2.5** are applicable to the peak ballast tanks only.

1.1.2.7 The Loading Manual is to include the design basis and operational limitations upon which the approval of the hull scantlings are based. The information listed in **Table 8.1.1** is to be included in the Loading Manual.

1.1.2.8 The approval of the hull scantlings is based on the rule defined loading patterns and the loading conditions given in the Loading Manual.

Table 8.1.1 Design Parameters

Parameter
Permissible limits of still water bending moments (seagoing operation and harbour/sheltered water operation)
Permissible limits of still water shear forces (seagoing operation and harbour/sheltered water operation)
Scantling draught, T_{sc}
Design minimum ballast draught at midships, T_{bal}
Design slamming draught forward with forward double bottom ballast tanks filled, $T_{FP-full}$
Design slamming draught forward with forward double bottom ballast tanks empty, T_{FP-nt}
Maximum allowable cargo density
Maximum cargo density in any loading condition in Loading Manual
Description of the ballast exchange operations including any limitations
Design speed

1.1.2.9 The following additional loading conditions are to be included in the Loading Manual if the ship is specifically approved and intended to be operated in such conditions:

- sea-going ballast conditions including water ballast carried in one or more cargo tanks which are intended for use in emergency situations as allowed by MARPOL ANNEX I, Regulation 13. (Ship approved for loading pattern A8 of **Table B.2.3** or B7 of **Table B.2.4**)
- seagoing loading conditions where the net static upward load on the double bottom exceeds that given with the combination of an empty cargo tank and a mean ship's draught of $0.9T_{sc}$
- seagoing loading conditions with cargo tanks less than 25% full with the combination of mean ship's draught greater than $0.9T_{sc}$
- seagoing loading conditions where the net static downward load on the double bottom exceeds that given with the combination of a full cargo tank at a cargo density of 1.025 tonnes/m^3 and a mean ship's draught of $0.6T_{sc}$
- for ships arranged with cross ties in the centre cargo tank, seagoing loading conditions showing a non-symmetric loading pattern where the difference in filling level between corresponding port and starboard wing cargo tanks exceeds 25% of the filling height in the wing cargo tank (Ship approved for loading pattern A7 of **Table B.2.3** or B7 of **Table B.2.4**)

1.1.2.10 This sub-section is not intended to prevent any other loading conditions to be included in the Loading Manual, nor is it intended to replace in any way the required Loading Manual/Instrument.

1.1.2.11 A tanker may in actual operation be loaded differently from the design loading conditions specified in the Loading Manual, provided limitations for longitudinal and local strength as defined in the Loading Manual and Loading Instrument onboard and applicable stability requirements are not exceeded.

1.1.3 Loading computer system

1.1.3.1 The loading computer system, is to be a system, which unless stated otherwise is digital and that can easily and quickly ascertain whether operational limitations are exceeded for any loading condition.

1.1.3.2 The loading computer system is to be approved based on **34.1.3, Part C** of the Rules.

1.1.3.3 The loading computer system is to be capable of producing any specific loading condition and verify that these comply with all the operational limitations given in **1.1.2.2**, and provide plots including input and output.

1.1.3.4 If any of the operational limitations are not checked, the user is to be properly informed when using the system, and by the plots provided, so that each such item is verified by other means. The loading computer system is as a minimum to verify that the following are satisfied:

- draught limitations
- still water bending moments and shear forces are reported at the specified locations/read-out points.

1.1.3.5 The final test conditions for the loading computer are to be based on conditions given in the final Loading Manual. The test conditions are subject to approval and the shear forces and bending moments calculated by the loading computer system, at each read out point, are to be within $0.02Q_{sw-perm}$ or $0.02M_{sw-perm}$ of the results given in

the loading manual, where $Q_{sw-perm}$ and $M_{sw-perm}$ are the assigned permissible shear force and bending moment at each read out point respectively.

1.1.3.6 Before a loading computer system is accepted, all relevant aspects of the computer, including but not limited to the following, are to be demonstrated to the Surveyor:

- (a) verification that the final data of the ship has been used
- (b) verification that the relevant limits for all read-out points are correct
- (c) that the operation of the system after installation onboard, is in accordance with the approved test conditions
- (d) that the approved test conditions are available onboard
- (e) that an operational manual is available onboard.

1.2 Hull Girder Bending Strength

1.2.1 General

1.2.1.1 The net vertical hull girder section modulus, $Z_{v-net50}$, is to be equal to or greater than the requirements given by 1.2.2.2 and 1.2.3.2. The net vertical hull girder moment of inertia, $I_{v-net50}$, as defined in Section 4/2.6.1.1 is to be equal to or greater than the requirement given by 1.2.2.1.

1.2.1.2 Scantlings of all continuous longitudinal members of the hull girder based on moment of inertia and section modulus requirement in 1.2.2.1 and 1.2.2.2 are to be maintained within $0.4L_{CSR-T}$ midships.

1.2.1.3 The hull girder section modulus requirements in 1.2.3 apply along the full length of the hull girder, from A.P. to F.P.

1.2.1.4 Structural members included in the hull girder section modulus are to satisfy the buckling criteria given in 1.4.

1.2.2 Minimum requirements

1.2.2.1 At the midship cross section the net vertical hull girder moment of inertia about the horizontal neutral axis, $I_{v-net50}$, is not to be less than the rule minimum vertical hull girder moment of inertia, I_{v-min} , defined as:

$$I_{v-min} = 2.7C_{wv}L_{CSR-T}^3 B(C_b + 0.7) \cdot 10^{-8} \quad (m^4)$$

Where:

C_{wv} : wave coefficient as defined in Table 8.1.2

L_{CSR-T} : rule length, in m , as defined in Section 4/1.1.1.1

B : moulded breadth, in m , as defined in Section 4/1.1.3.1

C_b : block coefficient, as defined in Section 4/1.1.9.1 but is not to be taken as less than 0.70

Table 8.1.2 Wave Coefficient C_{wv}

rule length	C_{wv}
$150 \leq L_{CSR-T} \leq 300$	$10.75 - [(300 - L_{CSR-T}) / 100]^{3/2}$
$300 < L_{CSR-T} < 350$	10.75
$350 \leq L_{CSR-T} \leq 500$	$10.75 - [(L_{CSR-T} - 350) / 150]^{3/2}$

1.2.2.2 At the midship cross section the net vertical hull girder section modulus, Z_{v-min} , at the deck and keel is not to be less than the rule minimum hull girder section modulus, Z_{v-min} , defined as:

$$Z_{v-min} = 0.9kC_{wv}L_{CSR-T}^2 B(C_b + 0.7) \cdot 10^{-6} \quad (m^3)$$

Where:

k : higher strength steel factor, as defined in Section 6/1.1.4

C_{wv} : wave coefficient as defined in Table 8.1.2

L_{CSR-T} : rule length, in m , as defined in Section 4/1.1.1.1

B : moulded breadth, in m , as defined in Section 4/1.1.3.1

C_b : block coefficient, as defined in Section 4/1.1.9.1 but is not to be taken as less than 0.70

1.2.2.3 The net hull girder section modulus at keel, $Z_{v-net50-kl}$, is to be calculated in accordance with Section 4/2.6.1.2 and taking z at the keel.

1.2.2.4 The net hull girder section modulus at deck, $Z_{v-net50-dk}$, is to be calculated in accordance with **Section 4/2.6.1.2** and taking z at the effective deck height, see **1.2.2.5**.

1.2.2.5 The effective deck height from the horizontal neutral axis for the hull girder section modulus, z_{dk-eff} , is to be taken as:

$$z_{dk-eff} = z_{dk-side} - z_{NA-net50} \quad (m)$$

When no effective longitudinal strength members are positioned above a line extending from moulded deck line at side to a position

$(z_{dk-side} - z_{NA-net50})/0.9$ from the neutral axis at the centreline

$$z_{dk-eff} = (z_y - z_{NA-net50}) \left(0.9 + 0.2 \frac{y_{cl}}{B} \right) \quad (m)$$

When any effective longitudinal strength members are positioned above a line extending from moulded deck line at side to a position

$(z_{dk-side} - z_{NA-net50})/0.9$ from the neutral axis at the centreline

Where:

- z_y : distance from the baseline to top of the continuous strength member at a distance y from the centreline, in m , giving the largest value of z_{dk-eff} , see **Fig. 8.1.1**
- $z_{NA-net50}$: distance from baseline to horizontal neutral axis, in m , see **Fig. 8.1.1**
- y_{cl} : distance from the top of the continuous strength member to the centreline of the ship, in m , giving the largest value of z_{dk-eff} , see **Fig. 8.1.1**
- B : moulded breadth, in m , as defined in **Section 4/1.1.3.1**
- $z_{dk-side}$: distance from the baseline to the moulded deck line at side, in m , see **Fig. 8.1.1**

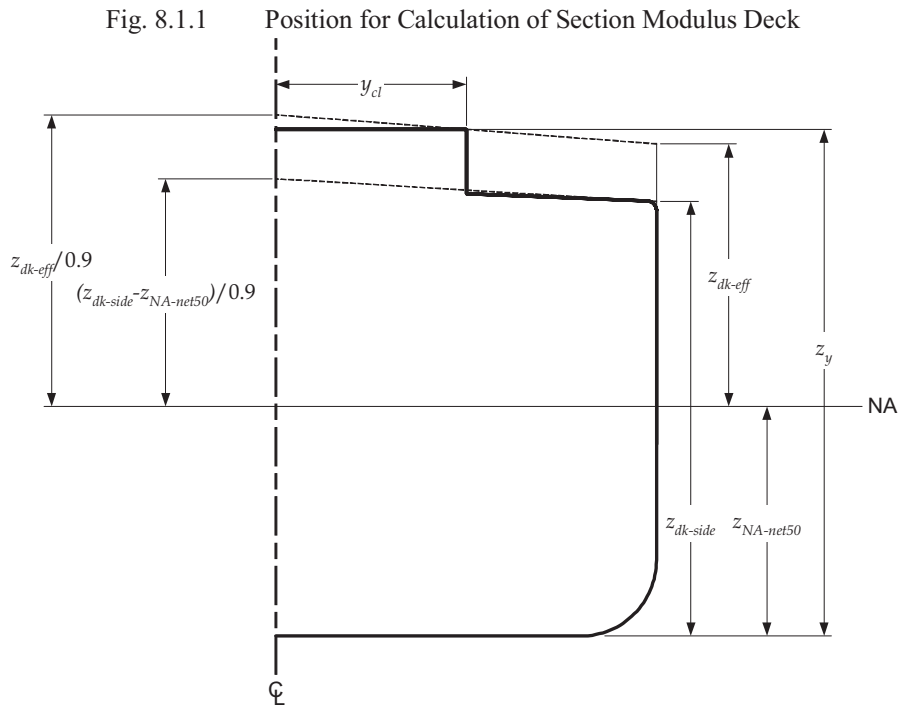

(a) Trunk deck or continuous hatch coaming

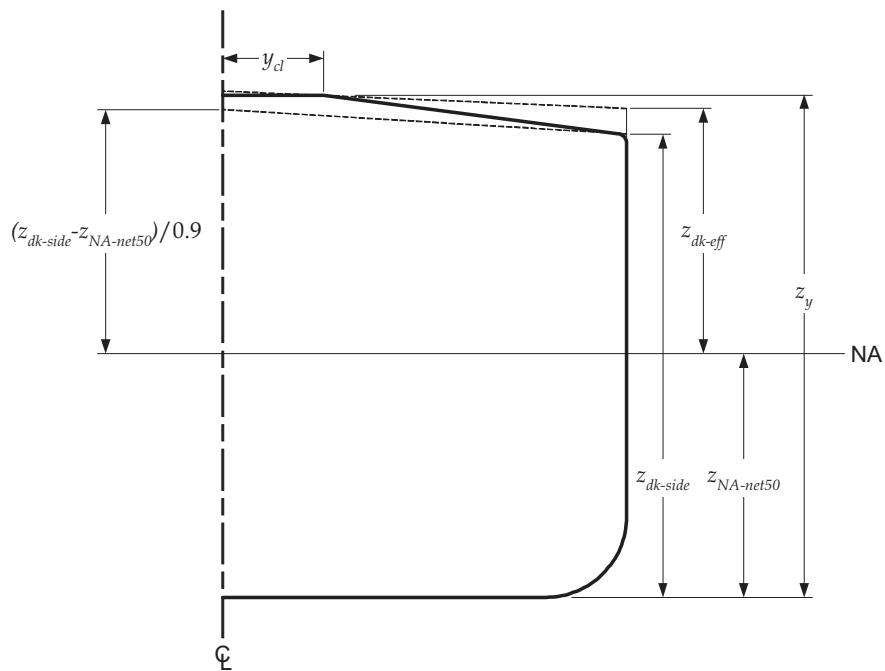

(b) Ship with large camber

1.2.3 Hull girder requirement on total design bending moment

1.2.3.1 The net vertical hull girder section modulus requirement as defined in 1.2.3.2 is to be assessed for both hogging and sagging conditions.

1.2.3.2 The net hull girder section modulus about the horizontal neutral axis, $Z_{v-net50}$, is not to be less than the rule required hull girder section modulus, Z_{v-req} , based on the permissible still-water bending moment and design wave bending moment defined as:

$$Z_{v-req} = \frac{|M_{sw-perm} + M_{wv-v}|}{\sigma_{perm}} 10^{-3} \quad (m^3)$$

Where:

- $M_{sw-perm}$: permissible hull girder hogging or sagging still water bending moment as given in **Table 8.1.3**, in kNm
 M_{wv-v} : hogging or sagging vertical wave bending moment, in kNm as given in **Table 8.1.3**
 σ_{perm} : permissible hull girder bending stress as given in **Table 8.1.3**, in N/mm^2

Table 8.1.3 Loads and Corresponding Acceptance Criteria for Hull Girder Bending Assessment

Design load combination	Still water bending moment, $M_{sw-perm}$	Wave bending moment, M_{wv-v}	Permissible hull girder bending stress, $\sigma_{perm}^{(1)}$	
(S)	$M_{sw-perm-harb}$	0	143/k	within $0.4L_{CSR-T}$ amidships
			105/k	at and forward of $0.9L_{CSR-T}$ from A.P. and at and aft of $0.1L_{CSR-T}$ from A.P.
(S + D)	$M_{sw-perm-sea}$	M_{wv-v}	190/k	within $0.4L_{CSR-T}$ amidships
			140/k	at and forward of $0.9L_{CSR-T}$ from A.P. and at and aft of $0.1L_{CSR-T}$ from A.P.

Where:

- $M_{sw-perm-harb}$: permissible hull girder hogging and sagging still water bending moment for harbour/sheltered water operation, in kNm , as defined in **Section 7/2.1.1**
 $M_{sw-perm-sea}$: permissible hull girder hogging and sagging still water bending moment for seagoing operation, in kNm , as defined in **Section 7/2.1.1**
 M_{wv-v} : hogging and sagging vertical wave bending moments, in kNm , as defined in **Section 7/3.4.1**
 M_{wv-v} is to be taken as:
 M_{wv-hog} for assessment with respect to hogging vertical wave bending moment
 M_{wv-sag} for assessment with respect to sagging vertical wave bending moment
 k : higher strength steel factor, as defined in **Section 6/1.1.4**

Note

1. σ_{perm} is to be linearly interpolated between values given.

1.3 Hull Girder Shear Strength

1.3.1 General

1.3.1.1 The hull girder shear strength requirements apply along the full length of the hull girder, from A.P. to F.P.

1.3.2 Assessment of hull girder shear strength

1.3.2.1 The net hull girder shear strength capacity, $Q_{v-net50}$, as defined in **1.3.2.2** is not to be less than the required vertical shear force, Q_{v-req} , as indicated in the following:

$$Q_{v-req} = Q_{sw-perm} + Q_{wv} \quad (kN)$$

Where:

- $Q_{sw-perm}$: permissible hull girder positive or negative still water shear force as given in **Section 7/2.1.3**, in kN
 Q_{wv} : vertical wave positive or negative shear force as defined in **Section 7/3.4.3**, in kN

1.3.2.2 The permissible positive and negative still water shear forces for seagoing and harbour/sheltered water operations, $Q_{sw-perm-sea}$ and $Q_{sw-perm-harb}$ are to satisfy:

$$Q_{sw-perm} \leq Q_{v-net50} - Q_{wv-pos} \quad (kN)$$

for maximum permissible positive shear force

$$Q_{sw-perm} \geq -Q_{v-net50} - Q_{wv-neg} \quad (kN)$$

for minimum permissible negative shear force

Where:

$Q_{sw-perm}$: permissible hull girder still water shear force as given in **Table 8.1.4**, in kN
 $Q_{v-net50}$: net hull girder vertical shear strength to be taken as the minimum for all plate elements that contribute to the hull girder shear capacity

$$= \frac{\tau_{ij-perm} t_{ij-net50}}{1000 q_v} \quad (kN)$$

$\tau_{ij-perm}$: permissible hull girder shear stress, τ_{perm} , as given in **Table 8.1.4**, in N/mm^2 , for plate ij

Q_{wv-pos} : positive vertical wave shear force, in kN , as defined in **Table 8.1.4**

Q_{wv-neg} : negative vertical wave shear force, in kN , as defined in **Table 8.1.4**

$t_{ij-net50}$: equivalent net thickness, t_{net50} , for plate ij , in mm . For longitudinal bulkheads between cargo tanks, t_{net50} is to be taken as $t_{sfc-net50}$ and t_{str-k} as appropriate, see **1.3.3.1** and **1.3.4.1**

t_{net50} : net thickness of plate, in mm
 $= t_{grs} - 0.5t_{corr}$

t_{grs} : gross plate thickness, in mm . The gross plate thickness for corrugated bulkheads is to be taken as the minimum of t_{w-grs} and t_{f-grs} , in mm

t_{w-grs} : gross thickness of the corrugation web, in mm

t_{f-grs} : gross thickness of the corrugation flange, in mm

t_{corr} : corrosion addition, in mm , as defined in **Section 6/3.2**

q_v : unit shear flow per mm for the plate being considered and based on the net scantlings. Where direct calculation of the unit shear flow is not available, the unit shear flow may be taken equal to:

$$= f_i \left(\frac{q_{l-net50}}{I_{v-net50}} \right) \cdot 10^{-9} \quad (mm^{-1})$$

f_i : shear force distribution factor for the main longitudinal hull girder shear carrying members being considered. For standard structural configurations f_i is as defined in **Fig. 8.1.2**

$q_{l-net50}$: first moment of area, in cm^3 , about the horizontal neutral axis of the effective longitudinal members between the vertical level at which the shear stress is being determined and the vertical extremity, taken at the section being considered. The first moment of area is to be based on the net thickness, t_{net50}

$I_{v-net50}$: net vertical hull girder section moment of inertia, in m^4 , as defined in **Section 4/2.6.1.1**

Table 8.1.4 Loads and Corresponding Acceptance Criteria for Hull Girder Shear Assessment

Design load combination	Still water shear force, $Q_{sw-perm}$	Vertical wave shear force, Q_{vw}	Permissible shear stress, τ_{perm}
Harbour/sheltered water operations (S)	$Q_{sw-perm-harb}$	0	105/k for plate ij
Seagoing operations (S + D)	$Q_{sw-perm-sea}$	Q_{vw}	120/k for plate ij

Where:

- $Q_{sw-perm-harb}$: permissible positive or negative hull girder still water shear force for harbour operation, in kN , as defined in **Section 7/2.1.3**
- $Q_{sw-perm-sea}$: permissible positive or negative hull girder still water shear force for seagoing operation, in kN , as defined in **Section 7/2.1.3**
- Q_{vw} : positive or negative vertical wave shear, in kN , as defined in **Section 7/3.4.3**. Q_{vw} is to be taken as:
 Q_{vw-pos} for assessment with respect to maximum positive permissible still water shear force
 Q_{vw-neg} for assessment with respect to minimum negative permissible still water shear force
- plate ij : for each plate j , index i denotes the structural member of which the plate forms a component
- k : higher strength steel factor, as defined in **Section 6/1.1.4**

Fig. 8.1.2 Shear Force Distribution Factors

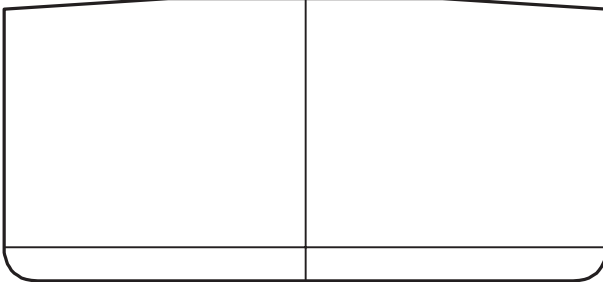
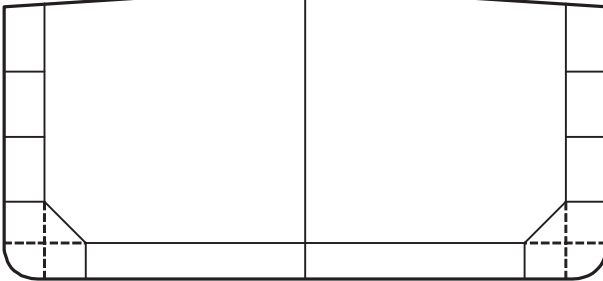
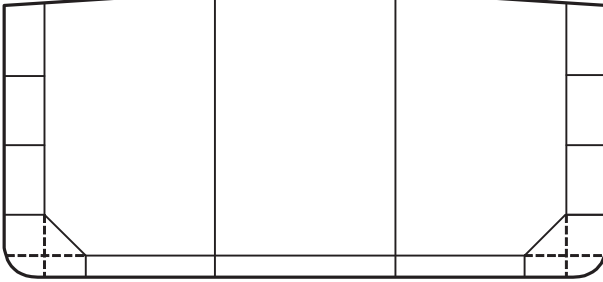
Hull configuration	f_i factors
<p>Outside cargo region (no longitudinal bulkhead)</p> 	<p>Side shell $f_1 = 0.5$</p>
<p>Outside cargo region (centreline bulkhead)</p> 	<p>Side shell $f_1 = 0.231 + 0.076 \frac{A_{1-net50}}{A_{3-net50}}$</p> <p>Longitudinal bulkhead $f_3 = 0.538 - 0.152 \frac{A_{1-net50}}{A_{3-net50}}$</p>
<p>One centreline bulkhead</p> 	<p>Side shell $f_1 = 0.055 + 0.097 \frac{A_{1-net50}}{A_{2-net50}} + 0.020 \frac{A_{2-net50}}{A_{3-net50}}$</p> <p>Inner hull $f_2 = 0.193 - 0.059 \frac{A_{1-net50}}{A_{2-net50}} + 0.058 \frac{A_{2-net50}}{A_{3-net50}}$</p> <p>Longitudinal bulkhead $f_3 = 0.504 - 0.076 \frac{A_{1-net50}}{A_{2-net50}} - 0.156 \frac{A_{2-net50}}{A_{3-net50}}$</p>
<p>Two longitudinal bulkheads</p> 	<p>Side shell $f_1 = 0.028 + 0.087 \frac{A_{1-net50}}{A_{2-net50}} + 0.023 \frac{A_{2-net50}}{A_{3-net50}}$</p> <p>Inner hull $f_2 = 0.119 - 0.038 \frac{A_{1-net50}}{A_{2-net50}} + 0.072 \frac{A_{2-net50}}{A_{3-net50}}$</p> <p>Longitudinal bulkhead $f_3 = 0.353 - 0.049 \frac{A_{1-net50}}{A_{2-net50}} - 0.095 \frac{A_{2-net50}}{A_{3-net50}}$</p>

Where:

i : index for the structural member under consideration

1, for the side shell

2, for the inner hull

3, for the longitudinal bulkhead

$A_{i-net50}$: net area as defined in Section 4/2.6.4 and based on deduction of $0.5t_{corr}$ of the structural member, i , at one side of the section under consideration. The area $A_{3-net50}$ for the centreline bulkhead is not to be reduced for symmetry around the centreline.

1.3.3 Shear force correction for longitudinal bulkheads between cargo tanks

1.3.3.1 For longitudinal bulkheads between cargo tanks the effective net plating thickness of the plating above the inner bottom, $t_{sfc-net50}$ for plate ij , used for calculation of hull girder shear strength, $Q_{v-net50}$, is to be corrected for local shear distribution and is given by:

$$t_{sfc-net50} = t_{grs} - 0.5t_{corr} - t_{\Delta} \quad (mm)$$

Where:

t_{grs} : gross plate thickness, in mm

t_{corr} : corrosion addition, in mm , as defined in **Section 6/3.2**

t_{Δ} : thickness deduction for plate ij , in mm , as defined in **1.3.3.2**

1.3.3.2 The vertical distribution of thickness reduction for shear force correction is assumed to be triangular as indicated in **Fig. 8.1.3**. The thickness deduction, t_{Δ} , to account for shear force correction is to be taken as:

$$t_{\Delta} = \frac{\delta Q_3}{h_{blk} \tau_{ij-perm}} \left(1 - \frac{x_{blk}}{0.5l_{tk}} \right) \left(2 - \frac{2(z_p - h_{db})}{h_{blk}} \right) \quad (mm)$$

Where:

δQ_3 : shear force correction for longitudinal bulkhead as defined in **1.3.3.3** and **1.3.3.5** for ships with one or two longitudinal bulkheads respectively, in kN .

l_{tk} : length of cargo tank, in m

h_{blk} : height of longitudinal bulkhead, in m , defined as the distance from inner bottom to the deck at the top of the bulkhead, as shown in **Fig. 8.1.3**

x_{blk} : the minimum longitudinal distance from section considered to the nearest cargo tank transverse bulkhead, in m . To be taken positive and not greater than $0.5l_{tk}$

z_p : the vertical distance from the lower edge of plate ij to the base line, in m . Not to be taken as less than h_{db}

h_{db} : height of double bottom, in m , as shown in **Fig. 8.1.3**

$\tau_{ij-perm}$: permissible hull girder shear stress, τ_{perm} , in N/mm^2 for plate ij
 $= 120/k_{ij}$

k_{ij} : higher strength steel factor, k , for plate ij as defined in **Section 6/1.1.4**

Fig. 8.1.3 Shear Force Correction for Longitudinal Bulkheads

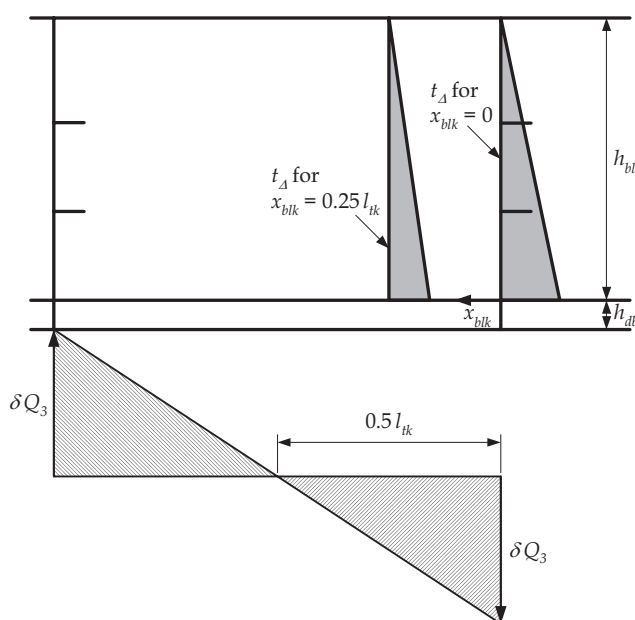

1.3.3.3 For ships with a centreline bulkhead between the cargo tanks, the shear force correction in way of transverse bulkhead, δQ_3 , is to be taken as:

$$\delta Q_3 = 0.5K_3F_{db} \quad (kN)$$

Where:

K_3 : correction factor, as defined in **1.3.3.4**

F_{db} : maximum resulting force on the double bottom in a tank, in kN , as defined in

1.3.3.7

1.3.3.4 For ships with a centreline bulkhead between the cargo tanks, the correction factor, K_3 , in way of transverse bulkheads is to be taken as:

$$K_3 = \left[0.40 \left(I - \frac{I}{I+n} \right) - f_3 \right]$$

Where:

n : number of floors between transverse bulkheads

f_3 : shear force distribution factor, see **Fig. 8.1.2**

1.3.3.5 For ships with two longitudinal bulkheads between the cargo tanks, the shear force correction, δQ_3 , is to be taken as:

$$\delta Q_3 = 0.5K_3F_{db} \quad (kN)$$

Where:

K_3 : correction factor, as defined in **1.3.3.6**

F_{db} : maximum resulting force on the double bottom in a tank, in kN , as defined in **1.3.3.7**

1.3.3.6 For ships with two longitudinal bulkheads between the cargo tanks, the correction factor, K_3 , in way of transverse bulkhead is to be taken as:

$$K_3 = \left[0.5 \left(I - \frac{I}{I+n} \right) \left(\frac{I}{r+I} \right) - f_3 \right]$$

Where:

n : number of floors between transverse bulkheads

r : ratio of the part load carried by the wash bulkheads and floors from longitudinal bulkhead to the double side and is given by

$$r = \frac{1}{\left[\frac{A_{3-net50}}{A_{1-net50} + A_{2-net50}} + \frac{2 \times 10^4 b_{80} (n_s + 1) A_{3-net50}}{l_{tk} (n_s A_{T-net50} + R)} \right]}$$

Note: for preliminary calculations, r may be taken as 0.5

l_{tk} : length of cargo tank, between transverse bulkheads in the side cargo tank, in m

b_{80} : 80% of the distance from longitudinal bulkhead to the inner hull longitudinal bulkhead, in m , at tank mid length

$A_{T-net50}$: net shear area of the transverse wash bulkhead, including the double bottom floor directly below, in the side cargo tank, in cm^2 , taken as the smallest area in a vertical section. $A_{T-net50}$ is to be calculated with net thickness given by $t_{grs} - 0.5t_{corr}$

$A_{1-net50}$: net area, as shown in **Fig. 8.1.2**, in m^2

$A_{2-net50}$: net area, as shown in **Fig. 8.1.2**, in m^2

$A_{3-net50}$: net area, as shown in **Fig. 8.1.2**, in m^2

f_3 : shear force distribution factor, as shown in **Fig. 8.1.2**

n_s : number of wash bulkheads in the side cargo tank

R : total efficiency of the transverse primary support members in the side tank

$$R = \left(\frac{n - n_s}{2} - 1 \right) \frac{A_{Q-net50}}{\gamma} \quad (cm^2)$$

$$\gamma = 1 + \frac{300b_{80}^2 A_{Q-net50}}{I_{psm-net50}}$$

$A_{Q-net50}$: net shear area, in cm^2 , of a transverse primary support member in the wing cargo tank, taken as the sum of the net shear areas of floor, cross ties and deck transverse webs. $A_{Q-net50}$ is to be calculated using the net thickness given by $t_{grs} - 0.5t_{corr}$. The net shear area is to be calculated at the mid span of the members.

$I_{psm-net50}$: net moment of inertia for primary support members, in cm^4 , of a transverse primary support member in the wing cargo tank, taken as the sum of the moments of inertia of transverses and cross ties.

It is to be calculated using the net thickness given by $t_{grs} - 0.5t_{corr}$.

The net moment of inertia is to be calculated at the mid span of the member including an attached plate width equal to the primary support member spacing

t_{grs} : gross plate thickness, in mm

t_{corr} : corrosion addition, in mm , as defined in **Section 6/3.2**

1.3.3.7 The maximum resulting force on the double bottom in a tank, F_{db} , is to be taken as:

$$F_{db} = g |W_{CT} + W_{CWBT} - \rho_{sw} b_2 l_{tk} T_{mean}| \quad (kN)$$

Where:

W_{CT} : weight of cargo, in *tonnes*, as defined in **Table 8.1.5**

W_{CWBT} : weight of ballast, in *tonnes*, as defined in **Table 8.1.5**

b_2 : breadth, in *m*, as defined in **Table 8.1.5**

l_{tk} : length of cargo tank, between watertight transverse bulkheads in the wing cargo tank, in *m*

T_{mean} : draught at the mid length of the tank for the loading condition considered, in *m*.

g : acceleration due to gravity, 9.81 m/s^2

ρ_{sw} : density of sea water, 1.025 tonnes/m^3

Table 8.1.5 Design Conditions for Double Bottoms

Structural Configuration	W_{CT}	W_{CWBT}	b_2
Ships with one longitudinal bulkhead	weight of cargo in cargo tanks, in <i>tonnes</i> , using a minimum specific gravity of 1.025 tonnes/m^3	weight of ballast between port and starboard inner sides, in <i>tonnes</i>	maximum breadth between port and starboard inner sides at mid length of tank, in <i>m</i> , as shown in Fig. 8.1.4
Ships with two longitudinal bulkheads	weight of cargo in the centre tank, in <i>tonnes</i> , using a minimum specific gravity of 1.025 tonnes/m^3	weight of ballast below the centre cargo tank, in <i>tonnes</i>	maximum breadth of the centre cargo tank at mid length of tank, in <i>m</i> , as shown in Fig. 8.1.4

1.3.3.8 The maximum resulting force on the double bottom in a tank, F_{db} , is in no case to be less than that given by the rule minimum conditions given in **Table 8.1.6**.

Table 8.1.6 Rule Minimum Conditions for Double Bottoms

Structural Configuration	Positive/negative force, F_{db}	Minimum condition
Ships with one longitudinal bulkhead	Max positive net vertical force, F_{db}^+	$0.9T_{sc}$ and empty cargo and ballast tanks
	Max negative net vertical force, F_{db}^-	$0.6T_{sc}$ and full cargo tanks and empty ballast tanks
Ships with two longitudinal bulkheads	Max positive net vertical force, F_{db}^+	$0.9T_{sc}$ and empty cargo and ballast tanks
	Max negative net vertical force, F_{db}^-	$0.6T_{sc}$ and full centre cargo tank and empty ballast tanks

Fig. 8.1.4 Tank Breadth to be Included for Different Tanker Types

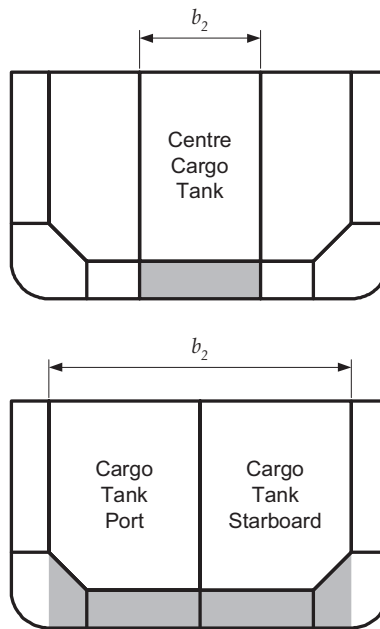

1.3.4 Shear force correction due to loads from transverse bulkhead stringers

1.3.4.1 In way of transverse bulkhead stringer connections, within areas as specified in **Fig. 8.1.6**, the equivalent net thickness of plate used for calculation of the hull girder shear strength, t_{str-k} , where the index k refers to the identification number of the stringer, is not to be taken greater than:

$$t_{str-k} = t_{sfc-net50} \left(1 - \frac{\tau_{str}}{\tau_{ij-perm}} \right) \quad (mm)$$

Where:

$t_{sfc-net50}$: effective net plating thickness, in mm , as defined in **1.3.3.1** and calculated at the transverse bulkhead for the height corresponding to the level of the stringer

$\tau_{ij-perm}$: permissible hull girder shear stress, τ_{perm} , for plate $ij = 120/k_{ij}$ (N/mm^2)

k_{ij} : higher strength steel factor, k , for plate ij as defined in **Section 6/1.1.4**

$$\tau_{str} = \frac{Q_{str-k}}{l_{str} t_{sfc-net50}} \quad (N/mm^2)$$

l_{str} : connection length of stringer, in m , see **Fig. 8.1.5**

Q_{str-k} : shear force on the longitudinal bulkhead from the stringer in loaded condition with tanks abreast full

$$= 0.8F_{str-k} \left(1 - \frac{z_{str} - h_{db}}{h_{blk}} \right) \quad (kN)$$

F_{str-k} : total stringer supporting force, in kN , as defined in **1.3.4.2**

- h_{db} : the double bottom height, in m , as shown in **Fig. 8.1.6**
 h_{blk} : height of bulkhead, in m , defined as the distance from inner bottom to the deck at the top of the bulkhead, as shown in **Fig. 8.1.6**
 z_{str} : the vertical distance from baseline to the considered stringer, in m .

1.3.4.2 The total stringer supporting force, F_{str-k} , in way of a longitudinal bulkhead is to be taken as:

$$F_{str-k} = \frac{P_{str} b_{str} (h_k + h_{k-1})}{2} \quad (kN)$$

Where:

- P_{str} : pressure on stringer, in kN/m^2 , to be taken as $10h_{tt}$
 h_{tt} : the height from the top of the tank to the midpoint of the load area between $h_k/2$ below the stringer and $h_{k-1}/2$ above the stringer, in m
 h_k : the vertical distance from the considered stringer to the stringer below. For the lowermost stringer, it is to be taken as 80 % of the average vertical distance to the inner bottom, in m
 h_{k-1} : the vertical distance from the considered stringer to the stringer above. For the uppermost stringer, it is to be taken as 80 % of the average vertical distance to the upper deck, in m
 b_{str} : load breadth acting on the stringer, in m , see **Fig. 8.1.7** and **8.1.8**

Fig. 8.1.5 Effective Connection Length of Stringer
stringer connection length

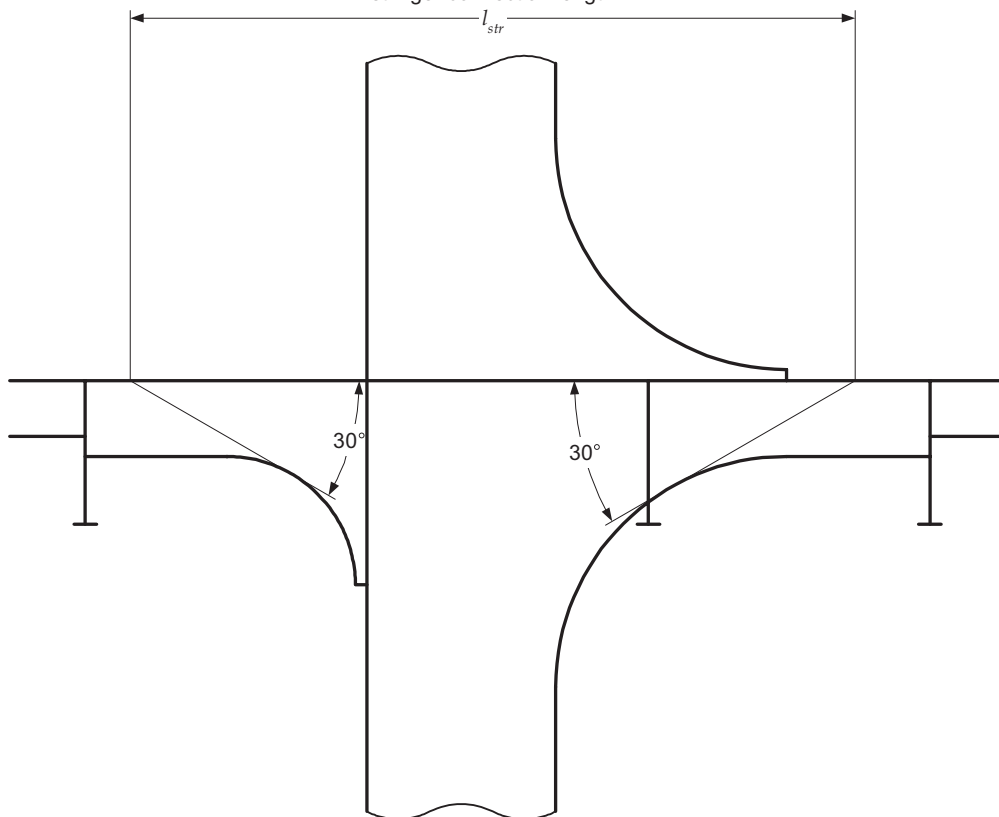

Fig. 8.1.6 Region for Stringer Correction, t_{ij} , for a Tanker with Three Stringers

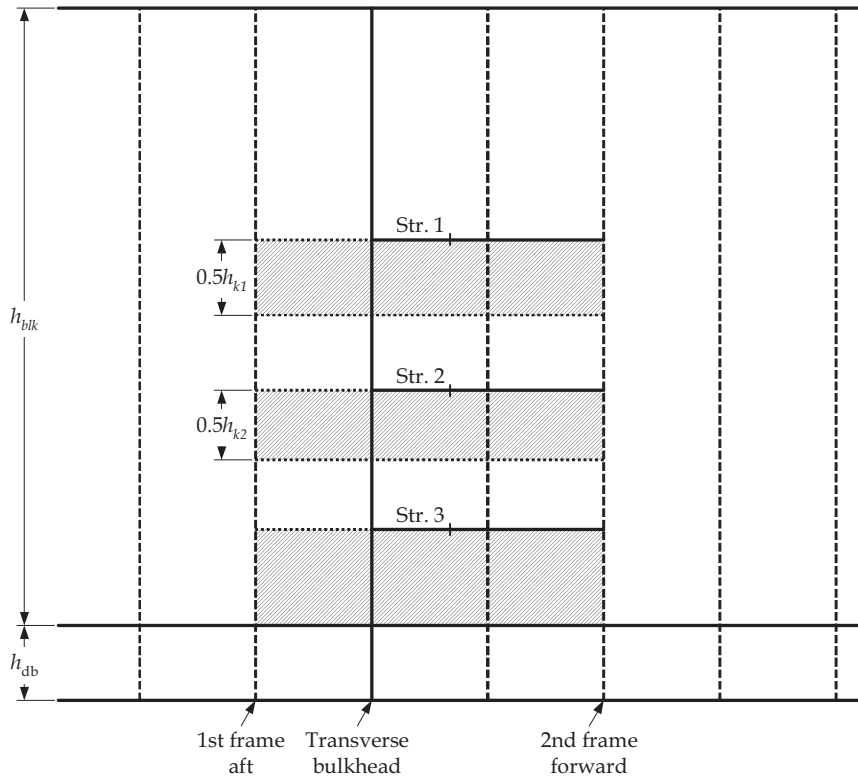
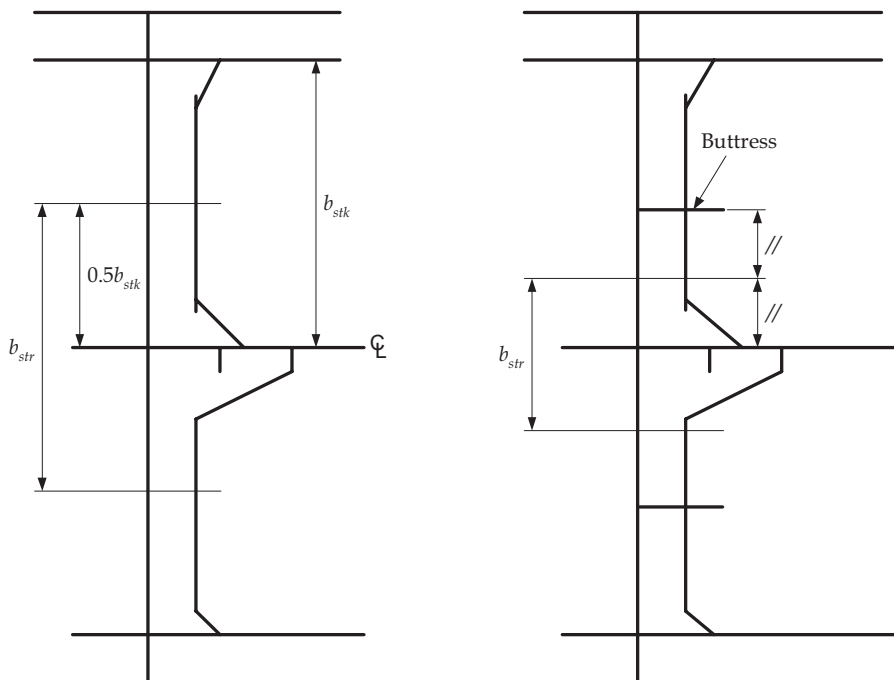
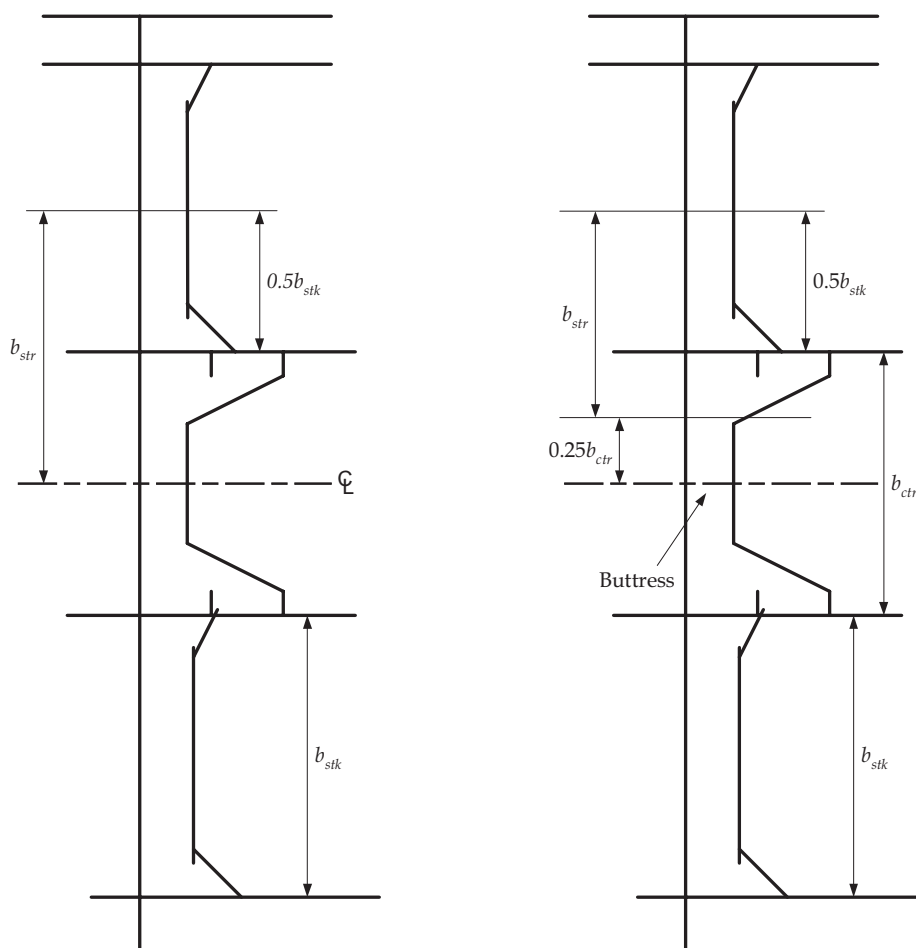

Fig. 8.1.7 Load Breadth of Stringers for Ships with a Centreline Bulkhead



1.3.4.3 Where reinforcement is provided to meet the above requirement, the reinforced area based on t_{str-k} is to extend longitudinally for the full length of the stringer connection and a minimum of one frame spacing forward and aft of the bulkhead. The reinforced area shall extend vertically from above the stringer level and down to $0.5h_k$ below the stringer, where h_k , the vertical distance from the considered stringer to the stringer below is as defined in 1.3.4.2. For the lowermost stringer the plate thickness requirement t_{str-k} is to extend down to the inner bottom, see Fig. 8.1.6.

Fig. 8.1.8 Load Breadth of Stringers for Ships with Two Inner Longitudinal Bulkheads



Notes

1. b_{stk} is the breadth of wing cargo tank, in m .
2. b_{ctr} is the breadth of centre cargo tank, in m .

1.4 Hull Girder Buckling Strength

1.4.1 General

1.4.1.1 These requirements apply to plate panels and longitudinals subject to hull girder compression and shear stresses. These stresses are to be based on the permissible values for still water bending and shear forces given in **Section 7/2.1**, and wave bending moments and shear forces given in **Section 7/3.4**.

1.4.1.2 The hull girder buckling strength requirements apply along the full length of the ship, from A.P to F.P.

1.4.1.3 For the purposes of assessing the hull girder buckling strength in this sub-section, the following are to be considered separately:

- (a) axial hull girder compressive stress to satisfy requirements in **1.4.2.6** and **1.4.2.8**
- (b) hull girder shear stress to satisfy requirements in **1.4.2.7**.

1.4.2 Buckling assessment

1.4.2.1 The buckling assessment of plate panels and longitudinals is to be determined according to **Section 10/3.1** with hull girder stresses calculated on net hull girder sectional properties.

1.4.2.2 The buckling strength for the buckling assessment is to be derived using local net scantlings, t_{net} , as follows:

$$t_{net} = t_{grs} - 1.0t_{corr} \quad (mm)$$

Where:

- t_{grs} : gross plate thickness, in mm
 t_{corr} : corrosion addition, in mm , as defined in **Section 6/3.2**

1.4.2.3 The hull girder compressive stress due to bending, $\sigma_{hg-net50}$, for the buckling assessment is to be calculated using net hull girder sectional properties and is to be taken as the greater of the following:

$$\sigma_{hg-net50} = \left| \frac{(z - z_{NA-net50}) (M_{sw-perm-sea} + M_{wv-v})}{I_{v-net50}} \right| 10^{-3} \quad (N/mm^2)$$

$$\sigma_{hg-net50} = \frac{30}{k} \quad (N/mm^2)$$

Where:

- $M_{sw-perm-sea}$: permissible still water bending moment for seagoing operation, in kNm , as defined in **Section 7/2.1.1**, with signs as given in **1.4.2.4**
 M_{wv-v} : hogging and sagging vertical wave bending moments, in kNm , as defined in **Section 7/3.4.1**, with signs as given in **1.4.2.4**
 M_{wv-v} is to be taken as:
 M_{wv-hog} for assessment with the hogging still water bending moment
 M_{wv-sag} for assessment with the sagging still water bending moment
 z : distance from the structural member under consideration to the baseline, in m
 $z_{NA-net50}$: distance from the baseline to the horizontal neutral, in m , see **Fig. 8.1.1**
 $I_{v-net50}$: net vertical hull girder section moment of inertia, in m^4 , as defined in **Section 4/2.6.1.1**
 k : higher strength steel factor, as defined in **Section 6/1.1.4.1**

1.4.2.4 The sagging bending moment values of $M_{sw-perm-sea}$ and M_{wv-v} are to be taken for members above the neutral axis. The hogging bending moment values are to be taken for members below the neutral axis.

1.4.2.5 The design hull girder shear stress for the buckling assessment, $\tau_{hg-net50}$, is to be calculated based on net hull girder sectional properties and is to be taken as:

$$\tau_{hg-net50} = \left| Q_{sw-perm-sea} + Q_{wv} \left(\frac{1000q_v}{t_{ij-net50}} \right) \right| \quad (N/mm^2)$$

Where:

- $Q_{sw-perm-sea}$: positive and negative still water permissible shear force for seagoing operation, in kN , as defined in **Section 7/2.1.3**
 Q_{wv} : positive or negative vertical wave shear, in kN , as defined in **Section 7/3.4.3**
 Q_{wv} is to be taken as:
 Q_{wv-pos} for assessment with the positive permissible still water shear force
 Q_{wv-neg} for assessment with the negative permissible still water shear force
 $t_{ij-net50}$: net thickness for the plate ij , in mm
 $= t_{ij-grs} - 0.5t_{corr}$
 t_{ij-grs} : gross plate thickness of plate ij , in mm . The gross plate thickness for corrugated bulkheads is to be taken as the minimum of t_{w-grs} and t_{f-grs} , in mm
 t_{w-grs} : gross thickness of the corrugation web, in mm
 t_{f-grs} : gross thickness of the corrugation flange, in mm
 t_{corr} : corrosion addition, in mm , as defined in **Section 6/3.2**
 q_v : unit shear per mm for the plate being considered as defined in **1.3.2.2**

Notes

- Maximum of the positive shear (still water + wave) and negative shear (still water + wave) is to be used as the basis for calculation of design shear stress
- All plate elements ij that contribute to the hull girder shear capacity are to be assessed. See also **Table 8.1.4** and **Fig. 8.1.2**
- The gross rule required thicknesses is to be calculated considering shear force correction.
- For longitudinal bulkheads between cargo tanks, $t_{ij-net50}$ is to be taken as $t_{sfc-net50}$ and t_{str-k} as appropriate.

1.4.2.6 The compressive buckling strength, of plate panels, is to satisfy the following criteria:

$$\eta \leq \eta_{allow}$$

Where:

η : buckling utilisation factor

$$\frac{\sigma_{hg-net50}}{\sigma_{cr}}$$

$\sigma_{hg-net50}$: hull girder compressive stress based on net hull girder sectional properties, in N/mm^2 as defined in **1.4.2.3**

σ_{cr} : critical compressive buckling stress, σ_{xcr} or σ_{ycr} as appropriate, in N/mm^2 , as specified in **Section 10/3.2.1.3**. The critical compressive buckling stress is to be calculated for the effects of hull girder compressive stress only. The effects of other membrane stresses and lateral pressure are to be ignored. The net thickness given as $t_{grs} - t_{corr}$ as described in **Section 6/3.3.2.2** is to be used for calculation of σ_{cr}

η_{allow} : allowable buckling utilisation factor:
= 1.0 for plate panels at or above $0.5D$
= 0.90 for plate panels below $0.5D$

t_{grs} : gross plate thickness, in mm

t_{corr} : corrosion addition, in mm , as defined in **Section 6/3.2**

1.4.2.7 The shear buckling strength, of plate panels, is to satisfy the following criteria:

$$\eta \leq \eta_{allow}$$

Where:

η : buckling utilisation factor

$$\frac{\tau_{hg-net50}}{\tau_{cr}}$$

$\tau_{hg-net50}$: design hull girder shear stress, in N/mm^2 , as defined in **1.4.2.5**

τ_{cr} : critical shear buckling stress, in N/mm^2 , as specified in **Section 10/3.2.1.3**. The critical shear buckling stress is to be calculated for the effects of hull girder shear stress only. The effects of other membrane stresses and lateral pressure are to be ignored. The net thickness given as $t_{grs} - t_{corr}$ as described in **Section 6/3.3.2.2** is to be used for the calculation of τ_{cr}

η_{allow} : allowable buckling utilisation factor
= 0.95

t_{grs} : gross plate thickness, in mm

t_{corr} : corrosion addition, in mm , as defined in **Section 6/3.2**

1.4.2.8 The compressive buckling strength of longitudinal stiffeners is to satisfy the following criteria:

$$\eta \leq \eta_{allow}$$

Where:

η : greater of the buckling utilisation factors given in **Section 10/3.3.2.1** and **Section 10/3.3.3.1**. The buckling utilisation factor is to be calculated for the effects of hull girder compressive stress only. The effects of other membrane stresses and lateral pressure are to be ignored.

η_{allow} : allowable buckling utilisation factor
= 1.0 for stiffeners at or above $0.5D$
= 0.90 for stiffeners below $0.5D$

1.5 Hull Girder Fatigue Strength

1.5.1 General

1.5.1.1 The following provides a simplified fatigue control measure against the dynamic hull girder stresses in the longitudinal deck structure.

1.5.1.2 The requirements in **1.5.1.3** are not mandatory, but are recommended to be applied in the early design phase in order to give an indication of the required hull girder section modulus for compliance with the mandatory fatigue requirements specified in **Section 9/3** and **Appendix C**.

1.5.1.3 The fatigue life for the deck structure as required by **Section 9/3** and **Appendix C** is normally satisfied providing the net vertical hull girder section modulus at the moulded deck line at side, $Z_{v-net50}$, as defined in **Section 4/2.6.1.1**, is not less than the required hull girder section modulus, Z_{v-fat} , defined as:

$$Z_{v-fat} = \frac{M_{wv-hog} - M_{wv-sag}}{1000R_{al}} \quad (m^3)$$

Where:

M_{wv-hog} : hogging vertical wave bending moment for fatigue, in kNm , as defined in **Section 7/3.4.1**

M_{wv-sag} : sagging vertical wave bending moment for fatigue, in kNm , as defined in **Section 7/3.4.1**

R_{al} : allowable stress range, in N/mm^2
 = $0.17L_{CSR-T} + 86$ for class F-details
 = $0.15L_{CSR-T} + 76$ for class F2-details

L_{CSR-T} : rule length, in m , as defined in **Section 4/1.1.1.1**

1.6 Tapering and Structural Continuity of Longitudinal Hull Girder Elements

1.6.1 Tapering based on minimum hull girder section property requirements

1.6.1.1 Scantlings of all continuous longitudinal members of the hull girder based on the moment of inertia and section modulus requirements given in **1.2.2** are to be maintained within $0.4L_{CSR-T}$ of amidships.

1.6.1.2 Scantlings outside of $0.4L_{CSR-T}$ amidships as required by the rule minimum moment of inertia and section modulus as given in **1.2.2** may be gradually reduced to the local requirements at the ends provided the hull girder bending and buckling requirements, along the full length of the ship, as given in **1.2.3** and **1.4** are complied with. For tapering of higher strength steel, see **1.6.2** and **1.6.3**.

1.6.2 Longitudinal extent of higher strength steel

1.6.2.1 Where used, the application of higher strength steel is to be continuous over the length of the ship up to locations where the longitudinal stress levels are within the allowable range for mild steel structure, see **Fig. 8.1.9**.

Fig. 8.1.9 Longitudinal Extent of Higher Strength Steel

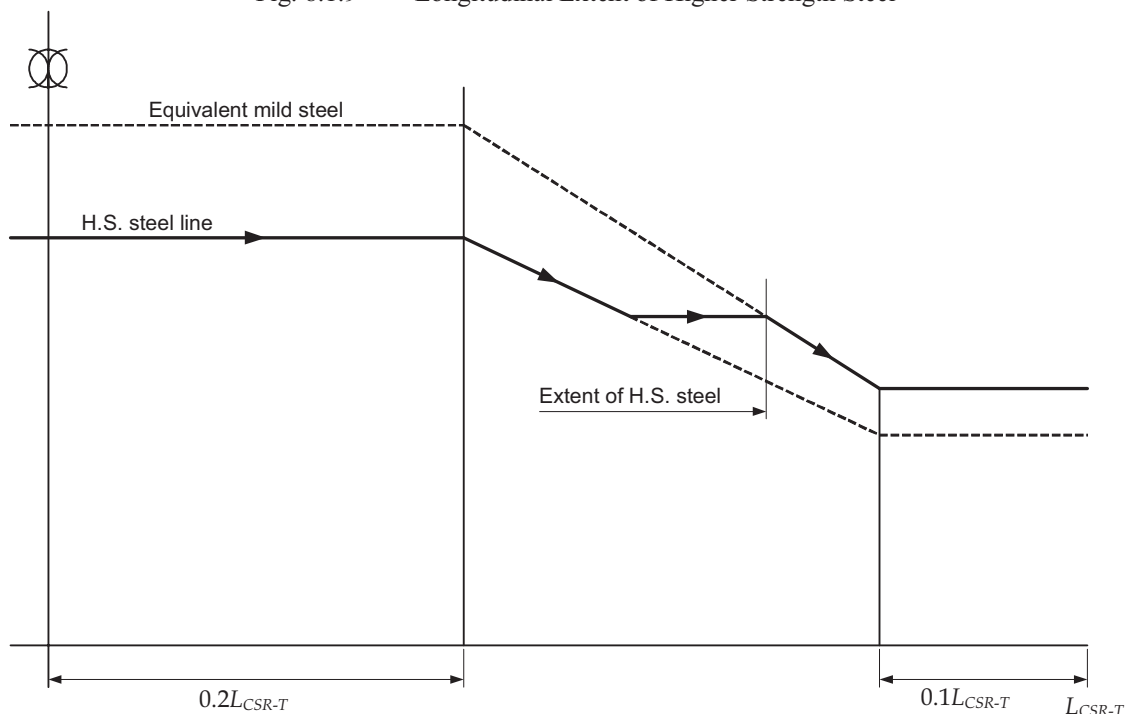

1.6.3 Vertical extent of higher strength steel

1.6.3.1 The vertical extent of higher strength steel, z_{hts} , used in the deck or bottom and measured from the moulded deck line at side or keel is not to be taken less than the following, see also **Fig. 8.1.10**.

$$z_{hts} = z_1 \left(1 - \frac{\sigma_{perm}}{\sigma_1} \right) \quad (m)$$

Where:

- z_1 : distance from horizontal neutral axis to moulded deck line or keel respectively, in m
- σ_1 : to be taken as σ_{dk} or σ_{kl} for the hull girder deck and keel respectively, in N/mm^2
- σ_{dk} : hull girder bending stress at moulded deck line given by:

$$= \frac{|M_{sw-perm-sea} + M_{wv-v}|}{I_{v-net50}} (z_{dk-side} - z_{NA-net50}) \cdot 10^{-3} \quad (N/mm^2)$$
- σ_{kl} : hull girder bending stress at keel given by:

$$= \frac{|M_{sw-perm-sea} + M_{wv-v}|}{I_{v-net50}} (z_{NA-net50} - z_{kl}) \cdot 10^{-3} \quad (N/mm^2)$$
- σ_{perm} : permissible hull girder bending stress as given in **Table 8.1.3** for design load combination S+D, in N/mm^2
- $M_{sw-perm-sea}$: permissible hull girder still water bending moment for seagoing operation, in kNm , as defined in **Section 7/2.1.1**
- M_{wv-v} : hogging and sagging vertical wave bending moments, in kNm , as defined in **Section 7/3.4.1**
 - M_{wv-v} is to be taken as:
 - M_{wv-hog} for assessment with respect to hogging vertical wave bending moment
 - M_{wv-sag} for assessment with respect to sagging vertical wave bending moment

- $I_{V-net50}$: net vertical hull girder moment of inertia, in m^4 , as defined in **Section 4/2.6.1.1**
- $z_{dk-side}$: distance from baseline to moulded deck line at side, in m
- z_{kl} : vertical distance from the baseline to the keel, in m
- $z_{NA-net50}$: distance from baseline to horizontal neutral axis, in m
- k_i : higher strength steel factor for the area i defined in **Fig. 8.1.10**.
The factor, k , is defined in **Section 6/1.1.4**

Fig. 8.1.10 Vertical Extent of Higher Strength Steel

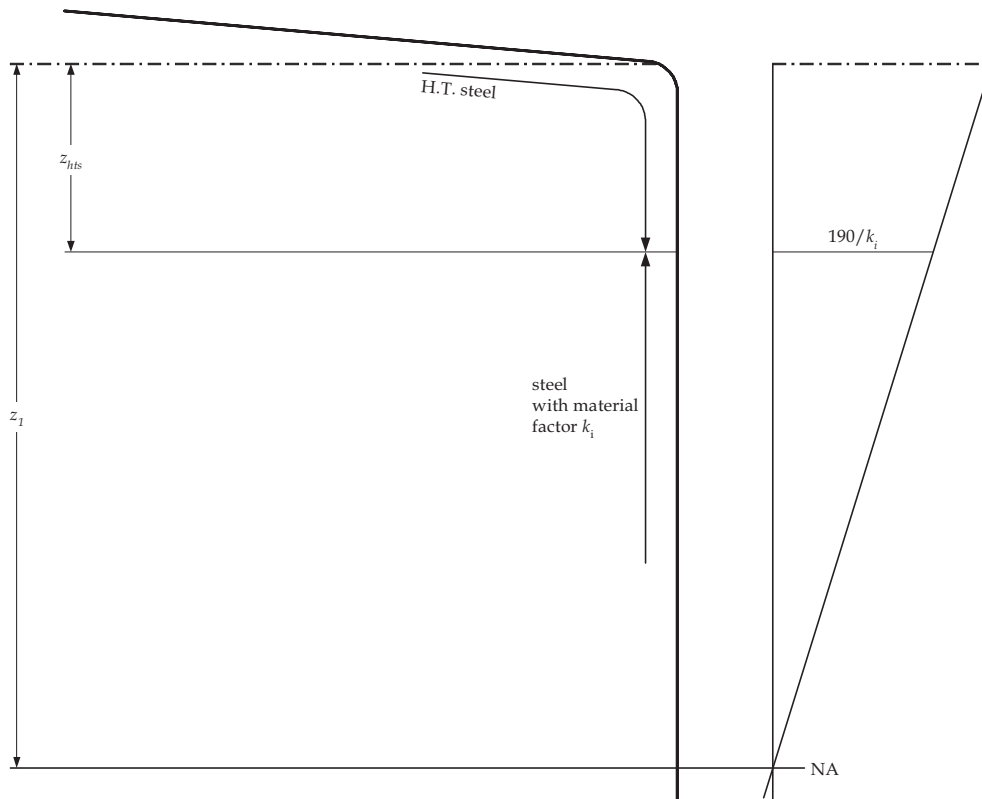

1.6.4 Tapering of plate thickness due to hull girder shear requirement

1.6.4.1 Longitudinal tapering of shear reinforcement is permitted, provided that for any longitudinal position the requirements given in 1.3.2 are complied with. Control of the shear strength at intermediate positions is to be carried out by linear interpolation of permissible shear limits at the bulkhead and in the middle of the tank.

1.6.5 Structural continuity of longitudinal bulkheads

1.6.5.1 Suitable scarphing arrangements are to be made to ensure continuity of strength and the avoidance of abrupt structural changes. In particular longitudinal bulkheads are to be terminated at an effective transverse bulkhead and large transition brackets shall be fitted in line with the longitudinal bulkhead.

1.6.6 Structural continuity of longitudinal stiffeners

1.6.6.1 Where longitudinal stiffeners terminate, and are replaced by a transverse system, adequate arrangements are to be made to avoid an abrupt changeover.

1.6.6.2 Where a deck longitudinal stiffener is cut, in way of an opening, compensation is to be arranged to ensure structural continuity of the area. The compensation area is to extend well beyond the forward and aft end of the opening and not be less than the area of the longitudinal that is cut. Stress concentration in way of the stiffener termination and the associated buckling strength of the plate and panel are to be considered.

2. Cargo Tank Region

2.1 General

2.1.1 Application

2.1.1.1 The requirements of this Sub-Section apply to the hull structure within the cargo tank region of the ship, for the shell, deck, inner bottom and bulkhead plating, stiffeners and primary support members.

2.1.2 Basis of scantlings

2.1.2.1 The net scantlings described in this Sub-Section are related to gross scantlings as follows:

- (a) for application of the minimum thickness requirements specified in **2.1.5** and **2.1.6**, the gross thickness is obtained from the applicable requirements by adding the full corrosion additions specified in **Section 6/3**
- (b) for plating and local support members, the gross thickness and gross cross sectional properties are obtained from the applicable requirements by adding the full corrosion additions specified in **Section 6/3**
- (c) for primary support members, the gross shear area, gross section modulus, and other gross cross sectional properties are obtained from the applicable requirements by adding one half of the relevant full corrosion addition specified in **Section 6/3**
- (d) for application of the buckling requirements of **Section 10/3**, the gross thickness and gross cross-sectional properties are obtained from the applicable requirements by adding the full corrosion additions specified in **Section 6/3**.

2.1.3 Evaluation of scantlings

2.1.3.1 The following scantling requirements are based on the assumption that all structural joints and welded details are designed and fabricated, such that they are to be compatible with the anticipated working stress levels at the locations considered. The loading patterns, stress concentrations and potential failure modes of structural joints and details during the design of highly stressed regions are to be considered. Structural design details are to comply with the requirements given in **Section 4/3**.

2.1.3.2 The scantlings are to be assessed to ensure that the strength criteria are satisfied at all longitudinal positions, where applicable.

2.1.3.3 Local scantling increases are to be applied where applicable to cover local variations, such as increased spacing, increased stiffener spans and green sea pressure loads. Local scantling increases may also be required to cover fore end strengthening requirements, see **Section 8/3**.

2.1.4 General scantling requirements

2.1.4.1 The hull structure is to comply with the applicable requirements of:

- (a) hull girder longitudinal strength, see **Section 8/1**
- (b) strength against sloshing and impact loads, see **Section 8/6**
- (c) hull girder ultimate strength, see **Section 9**
- (d) strength assessment (FEM), see **Section 9**
- (e) fatigue strength, see **Section 9/3**
- (f) buckling and ultimate strength, see **Section 10**.

2.1.4.2 The net section modulus, shear areas and other sectional properties of the local and primary support members are to be determined in accordance with **Section 4/2**.

2.1.4.3 The section modulus, shear areas and other sectional properties of the local and primary support members apply to the areas clear of the end brackets.

2.1.4.4 The spans of the local and primary support members are defined in **Section 4/2.1**.

2.1.4.5 The moments of inertia for the primary support members are to be determined in association with the effective attached plating at the mid span as specified in **Section 4/2.3.2.3**.

2.1.4.6 Limber, drain and air holes are to be cut in all parts of the structure, as required, to ensure the free flow to the suction pipes and escape of air to the vents. See also **Section 4/3**.

2.1.4.7 All shell frames and tank boundary stiffeners are in general to be continuous, or are to be bracketed at their ends, except as permitted in **Sections 4/3.2.4** and **4/3.2.5**.

2.1.4.8 Enlarged stiffeners (with or without web stiffening) used for Permanent Means of Access (*PMA*) are to comply with the following requirements:

- (a) Buckling strength including proportion (slenderness ratio) requirements for primary support members as follows:
- For stiffener web, see **Section 10/2.3.1.1(a)**, **10/3.2**.
 - For stiffener flange, see **Section 10/2.3.1.1(b)**, **10/2.3.3.1**.
 - For web stiffeners, see **Section 10/2.3.2.1**, **10/2.3.2.2**, **10/3.3**.

Note: **Note 1** of **table 10.2.1** is not applicable.

(b) Buckling strength of longitudinal *PMA* platforms without web stiffeners may also be ensured using the criteria for local support members in **Section 10/2.2** and **Section 10/3.3**, including **Note 1** of **Table 10.2.1**, provided shear buckling strength of web is verified in line with **Section 10/3.2**.

- (c) All other requirements for local support members as follows:
- Corrosion additions: requirements for local support members
 - Minimum thickness: requirements for local support members
 - Fatigue: requirements for local support members

Note: For primary support members (or part of it) used as a *PMA* platform the requirements for primary support members are to be applied.

2.1.5 Minimum thickness for plating and local support members

2.1.5.1 The thickness of plating and stiffeners in the cargo tank region is to comply with the appropriate minimum thickness requirements given in **Table 8.2.1**.

Table 8.2.1 Minimum Net Thickness for Plating and Local Support Members in the Cargo Tank Region

Scantling Location		Net Thickness (mm)	
Plating	Shell	Keel plating	$6.5+0.03L_2$
		Bottom shell/bilge/side shell	$4.5+0.03L_2$
	Upper Deck		$4.5+0.02L_2$
	Other structure	Hull internal tank boundaries	$4.5+0.02L_2$
Non-tight bulkheads, bulkheads between dry spaces and other plates in general		$4.5+0.01L_2$	
Local support members	Local support members on tight boundaries	$3.5+0.015L_2$	
	Local support members on other structure	$2.5+0.015L_2$	
Tripping brackets		$5.0+0.015L_2$	

Where:

L_2 : rule length, L_{CSR-T} , as defined in **Section 4/1.1.1.1**, but need not be taken greater than 300m

2.1.6 Minimum thickness for primary support members

2.1.6.1 The thickness of web plating and face plating of primary support members in the cargo tank region is to comply with the appropriate minimum thickness requirements given in **Table 8.2.2**.

Table 8.2.2 Minimum Net Thickness for Primary Support Members in Cargo Tank Region

Scantling Location	Net Thickness (mm)
Double bottom centreline girder	$5.5+0.025L_2$
Other double bottom girders	$5.5+0.02L_2$
Double bottom floors, web plates of side transverses and stringers in double hull	$5.0+0.015L_2$
Web and flanges of vertical web frames on longitudinal bulkheads, horizontal stringers on transverse bulkhead, deck transverses (above and below upper deck) and cross ties	$5.5+0.015L_2$

Where:

L_2 : rule length, L_{CSR-T} , as defined in **Section 4/1.1.1.1**, but need not be taken greater than 300m

2.2 Hull Envelope Plating

2.2.1 Keel plating

2.2.1.1 Keel plating is to extend over the flat of bottom for the complete length of the ship. The breadth, b_{kl} , is not to be less than:

$$b_{kl} = 800 + 5L_2 \quad (mm)$$

Where:

L_2 : rule length, L_{CSR-T} , as defined in **Section 4/1.1.1.1**, but not to be taken greater than 300m

2.2.1.2 The thickness of the keel plating is to comply with the requirements given in **2.2.2**.

2.2.2 Bottom shell plating

2.2.2.1 The thickness of the bottom shell plating is to comply with the requirements in **Table 8.2.4**.

2.2.3 Bilge plating

2.2.3.1 The thickness of bilge plating is not to be less than that required for the adjacent bottom shell, see **2.2.2.1**, or adjacent side shell plating, see **2.2.4.1**, whichever is the greater.

2.2.3.2 The net thickness of bilge plating, t_{net} , without longitudinal stiffening is not to be less than:

$$t_{net} = \frac{\sqrt[3]{r^2 S_t P_{ex}}}{100} \quad (mm)$$

Where:

P_{ex} : design sea pressure for the design load set 1 calculated at the lower turn of bilge, in kN/m^2

r : effective bilge radius
 $= r_0 + 0.5(a + b) \quad (mm)$

r_0 : radius of curvature, in mm . See **Fig. 8.2.1**

S_t : distance between transverse stiffeners, webs or bilge brackets, in m

a : distance between the lower turn of bilge and the outermost bottom longitudinal, in mm , see **Fig. 8.2.1** and **2.3.1.2**. Where the outermost bottom longitudinal is within the curvature, this distance is to be taken as zero.

b : distance between the upper turn of bilge and the lowest side longitudinal, in mm , see **Fig. 8.2.1** and **2.3.1.2**. Where the lowest side longitudinal is within the curvature, this distance is to be taken as zero.

Where plate seam is located in the straight plate just below the lowest stiffener on the side shell, any increased thickness required for the bilge plating does not have to extend to the adjacent plate above the bilge provided that the plate seam is not more than $sb/4$ below the lowest side longitudinal. Similarly for flat part of adjacent bottom plating, any increased thickness for the bilge plating does not have to be applied provided that the plate seam is not more than $sa/4$ beyond the outboard bottom longitudinal. Regularly

longitudinally stiffened bilge plating is to be assessed as a stiffened plate. The bilge keel is not considered as “longitudinal stiffening” for the application of this requirement.

Fig. 8.2.1 Unstiffened Bilge Plating

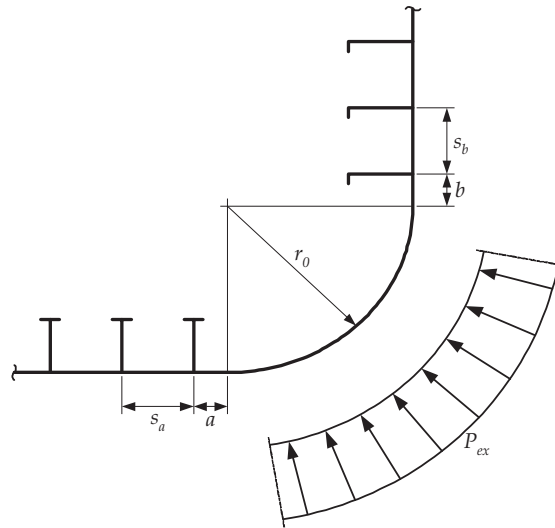

2.2.3.3 Where bilge longitudinals are omitted, the bilge plate thickness outside $0.4L_{CSR-T}$ amidships will be considered in relation to the support derived from the hull form and internal stiffening arrangements. In general, outside of $0.4L_{CSR-T}$ amidships the bilge plate scantlings and arrangement are to comply with the requirements of ordinary side or bottom shell plating in the same region. Consideration is to be given where there is increased loading in the forward region.

2.2.4 Side shell plating

2.2.4.1 The thickness of the side shell plating is to comply with the requirements in **Table 8.2.4**.

2.2.4.2 The net thickness, t_{net} , of the side plating within the range as specified in **2.2.4.3** is not to be less than:

$$t_{net} = 26 \left(\frac{s}{1000} + 0.7 \right) \left(\frac{BT_{sc}}{\sigma_{yd}^2} \right)^{0.25} \quad (mm)$$

Where:

- s : stiffener spacing, in mm , as defined in **Section 4/2.2**
- B : moulded breadth, in m as defined in **Section 4/1.1.3.1**
- T_{sc} : scantling draught, in m , as defined in **Section 4/1.1.5.5**
- σ_{yd} : specified minimum yield stress of the material, in N/mm^2

2.2.4.3 The thickness in **2.2.4.2** is to be applied to the following extent of the side shell plating, see **Fig. 8.2.2**:

- (a) longitudinal extent:
 - between a section aft of amidships where the breadth at the waterline exceeds $0.9B$, and a section forward of amidships where the breadth at the waterline exceeds $0.6B$
- (b) vertical extent:
 - between $300mm$ below the minimum design ballast waterline, T_{bal} , amidships to $0.25T_{sc}$ or $2.2m$, whichever is greater, above the draught T_{sc} .

Fig. 8.2.2 Extent of Side Shell Plating

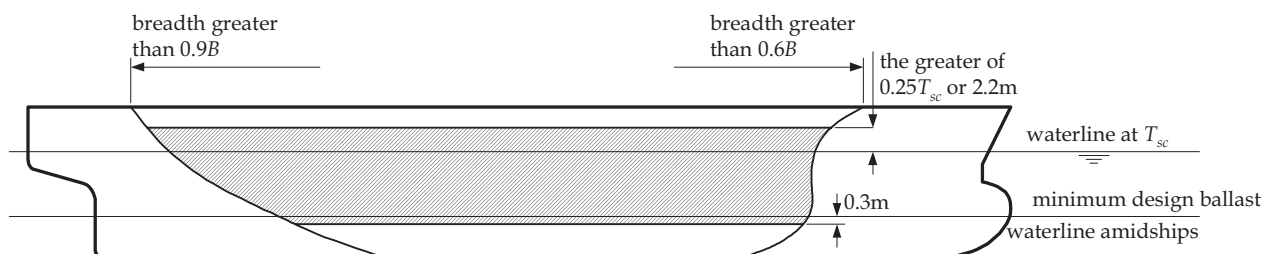

2.2.5 Sheer strake

2.2.5.1 The sheer strake is to comply with the requirements in **2.2.4**.

2.2.5.2 The welding of deck fittings to rounded sheer strakes is to be avoided within $0.6L_{CSR-T}$ of amidships.

2.2.5.3 Where the sheer strake extends above the deck stringer plate, the top edge of the sheer strake is to be kept free from notches and isolated welded fittings, and is to be smooth with rounded edges. Grinding may be required if the cutting surface is not smooth. Drainage openings with a smooth transition in the longitudinal direction may be permitted.

2.2.6 Deck plating

2.2.6.1 The thickness of the deck plating is to comply with the requirements given in **Table 8.2.4**.

2.3 Hull Envelope Framing**2.3.1 General**

2.3.1.1 The bottom shell, inner bottom and deck are to be longitudinally framed in the cargo tank region. The side shell, inner hull bulkheads and longitudinal bulkheads are generally to be longitudinally framed. Where the side shell is longitudinally framed, the inner hull bulkheads are to be similarly constructed. Suitable alternatives which take account of resistance to buckling will be specially considered.

2.3.1.2 Where longitudinals are omitted in way of the bilge, a longitudinal is to be fitted at the bottom and at the side close to the position where the curvature of the bilge plate starts. The distance between the lower turn of bilge and the outermost bottom longitudinal, a , is generally not to be greater than one-third of the spacing between the two outermost bottom longitudinals, s_a . Similarly, the distance between the upper turn of the bilge and the lowest side longitudinal, b , is generally not to be greater than one-third of the spacing between the two lowest side longitudinals, s_b . See **Fig. 8.2.1**.

2.3.1.3 The longitudinals are to comply with the requirements of continuity given in **Section 4/3.2**.

2.3.2 Scantling criteria

2.3.2.1 The section modulus, and thickness, of the hull envelope framing is to comply with the requirements given in **Tables 8.2.5** and **8.2.6**.

2.3.2.2 Where the side shell longitudinal or the vertical stiffener is inclined to the longitudinal or vertical axis, respectively, the span is to be taken in accordance with **Section 4/2.1.3**.

2.3.2.3 For curved stiffeners, the span is to be taken in accordance with **Section 4/2.1.3**.

2.4 Inner Bottom**2.4.1 Inner bottom plating**

2.4.1.1 The thickness of the inner bottom plating is to comply with the requirements given in **Table 8.2.4**.

2.4.1.2 In way of a welded hopper knuckle, the inner bottom is to be scarfed to ensure adequate load transmission to surrounding structure and reduce stress concentrations.

2.4.1.3 In way of corrugated bulkhead stools, where fitted, particular attention is to be given to the through-thickness properties, and arrangements for continuity of strength, at the connection of the bulkhead stool to the inner bottom.

For requirements for plates with specified through-thickness properties, see **Section 6/1.1.5**.

2.4.2 Inner bottom longitudinals

2.4.2.1 The section modulus and web plate thickness of the inner bottom longitudinals are to comply with the requirements given in **Tables 8.2.5** and **8.2.6**.

2.5 Bulkheads**2.5.1 General**

2.5.1.1 The inner hull and longitudinal bulkheads are generally to be longitudinally framed, and plane. Corrugated bulkheads are to comply with the requirements given in **2.5.6**.

2.5.1.2 Where bulkheads are penetrated by cargo or ballast piping, the structural arrangements in way are to be adequate for the loads imparted to the bulkheads by the hydraulic forces in the pipes.

2.5.2 Longitudinal tank boundary bulkhead plating

2.5.2.1 The thickness of the longitudinal tank boundary bulkhead plating is to comply with the requirements given in **Table 8.2.4**.

2.5.2.2 Inner hull and longitudinal bulkheads are to extend as far forward and aft as practicable and are to be effectively scarfed into the adjoining structure.

2.5.3 Hopper side structure

2.5.3.1 Knuckles in the hopper tank plating are to be supported by side girders and stringers, or by a deep longitudinal.

2.5.4 Transverse tank boundary bulkhead plating

2.5.4.1 The thickness of the transverse tank boundary bulkhead plating is to comply with the requirements given in **Table 8.2.4**.

2.5.5 Tank boundary bulkhead stiffeners

2.5.5.1 The section modulus and web thickness of stiffeners, on longitudinal or transverse tank boundary bulkheads, are to comply with the requirements given in **Tables 8.2.5** and **8.2.6**.

2.5.6 Corrugated bulkheads

2.5.6.1 The scantling requirements relating to corrugated bulkheads defined in **2.5.6** and **2.5.7** are net requirements. The gross scantling requirements are obtained from the applicable requirements by adding the full corrosion additions specified in **Section 6/3**.

2.5.6.2 In general, corrugated bulkheads are to be designed with the corrugation angles, ϕ , between 55 and 90 degrees, see **Fig. 8.2.3**.

2.5.6.3 The global strength of corrugated bulkheads, lower stools and upper stools, where fitted, and attachments to surrounding structures are to be verified with the cargo tank FEM model in the midship region, see **Section 9/2**. The global strength of corrugated bulkheads outside of midship region are to be considered based on results from the cargo tank FEM model and using the appropriate pressure for the bulkhead being considered. Additional FEM analysis of cargo tank bulkheads forward and aft of the midship region may be necessary if the bulkhead geometry, structural details and support arrangement details differ significantly from bulkheads within the mid cargo tank region.

2.5.6.4 The net thicknesses, t_{net} , of the web and flange plates of corrugated bulkheads are to be taken as the greatest value calculated for all applicable design load sets, as given in **Table 8.2.7**, and given by:

$$t_{net} = 0.0158 b_p \sqrt{\frac{|P|}{C_a \sigma_{yd}}} \quad (mm)$$

Where:

P : design pressure for the design load set being considered, calculated at the load point defined in **Section 3/5.1**, in kN/m^2

b_p : breadth of plate
 = b_f for flange plating, in mm . See **Fig. 8.2.3**
 = b_w for web plating, in mm . See **Fig. 8.2.3**

C_a : permissible bending stress coefficient
 = 0.75 for acceptance criteria set AC1
 = 0.90 for acceptance criteria set AC2

σ_{yd} : specified minimum yield stress of the material, in N/mm^2

2.5.6.5 Where the corrugated bulkhead is built with flange and web plate of different thickness, then the thicker net plating thickness, t_{m-net} , is to be taken as the greatest value calculated for all applicable design load sets, as given in **Table 8.2.7**, and given by:

$$t_{m-net} = \sqrt{\frac{0.0005 b_p^2 |P|}{C_a \sigma_{yd}} - t_{n-net}^2} \quad (mm)$$

Where:

t_{n-net} : net thickness of the thinner plating, either flange or web, in mm

- b_p : breadth of thicker plate, either flange or web, in *mm*
 P : design pressure for the design load set being considered, calculated at the load point defined in **Section 3/5.1**, in kN/m^2
 C_a : permissible bending stress coefficient
 = 0.75 for acceptance criteria set AC1
 = 0.90 for acceptance criteria set AC2
 σ_{yd} : specified minimum yield stress of the material, in N/mm^2

2.5.7 Vertically corrugated bulkheads

2.5.7.1 In addition to the requirements of **2.5.6**, vertically corrugated bulkheads are also to comply with the requirements of **2.5.7**.

2.5.7.2 The net plate thicknesses as required by **2.5.7.5** and **2.5.7.6** are to be maintained for two thirds of the corrugation length, l_{cg} , from the lower end, where l_{cg} is as defined in **2.5.7.3**. Above that, the net plate thickness may be reduced by 20%.

2.5.7.3 The net web plating thickness of the lower 15% of the corrugation, t_{w-net} , is to be taken as the greatest value calculated for all applicable design load sets, as given in **Table 8.2.7**, and given by the following. This requirement is not applicable to corrugated bulkheads without a lower stool, see **2.5.7.9**.

$$t_{w-net} = \frac{1000|Q_{cg}|}{d_{cg} C_{t-cg} \tau_{yd}} \quad (mm)$$

Where:

Q_{cg} : design shear force imposed on the web plating at the lower end of the corrugation

$$= \frac{s_{cg} l_{cg} |3P_l + P_u|}{8000} \quad (kN)$$

P_l : design pressure for the design load set being considered, calculated at the lower end of the corrugation, in kN/m^2

P_u : design pressures for the design load set being considered, calculate at the upper end of the corrugation, in kN/m^2

s_{cg} : spacing of corrugation, in *mm*. See **Fig. 8.2.3**

l_{cg} : length of corrugation, which is defined as the distance between the lower stool and the upper stool or the upper end where no upper stool is fitted, in *m*, see **Fig. 8.2.3**

d_{cg} : depth of corrugation, in *mm*. See **2.5.7.4** and **Fig. 8.2.3**

C_{t-cg} : permissible shear stress coefficient
 = 0.75 for acceptance criteria set AC1
 = 0.90 for acceptance criteria set AC2

$$\tau_{yd} = \frac{\sigma_{yd}}{\sqrt{3}} \quad N/mm^2$$

σ_{yd} : specified minimum yield stress of the material, in N/mm^2

2.5.7.4 The depth of the corrugation, d_{cg} , is not to be less than:

$$d_{cg} = \frac{1000l_{cg}}{15} \quad (mm)$$

Where:

l_{cg} : length of corrugation, which is defined as the distance between the lower stool or the inner bottom if no lower stool is fitted and the upper stool or the upper end where no upper stool is fitted, in *m*, see **Fig. 8.2.3**

2.5.7.5 The net thicknesses of the flanges of corrugated bulkheads, t_{f-net} , for two thirds of the corrugation length from the lower end are to be taken as the greatest value calculated for all applicable design load sets, as given in **Table 8.2.7**, and given by the following. This requirement is not applicable to corrugated bulkheads without a lower stool, see **2.5.7.9**.

$$t_{f-net} = \frac{0.00657 b_f \sqrt{\sigma_{bdg-max}}}{C_f} \quad (mm)$$

Where:

$\sigma_{bdg-max}$: maximum value of the vertical bending stresses in the flange. The bending stress is to be calculated at the lower end and at the mid span of the corrugation length

$$= \frac{1000 M_{cg}}{Z_{cg-act-net}} \quad (N/mm^2)$$

M_{cg} : as defined in **2.5.7.6**

$Z_{cg-act-net}$: actual net section modulus at the lower end and at the mid length of the corrugation, in cm^3

b_f : breadth of flange plating, in mm . See **Fig. 8.2.3**

b_w : breadth of web plating, in mm . See **Fig. 8.2.3**

C_f : coefficient

$$= 7.65 - 0.26 \left(\frac{b_w}{b_f} \right)^2$$

2.5.7.6 The net section modulus at the lower and upper ends and at the mid length of the corrugation ($l_{cg}/2$) of a unit corrugation, Z_{cg-net} , are to be taken as the greatest value calculated for all applicable design load sets, as given in **Table 8.2.7**, and given by the following.

$$Z_{cg-net} = \frac{1000 M_{cg}}{C_{s-cg} \sigma_{yd}} \quad (cm^3)$$

Where:

$$M_{cg} = \frac{C_i |P| s_{cg} l_o^2}{12000} \quad (kNm)$$

$$P = \frac{P_u + P_l}{2} \quad (kN/m^2)$$

P_l, P_u : design pressure for the design load set being considered, calculated at the lower and upper ends of the corrugation, respectively, in kN/m^2

(a) for transverse corrugated bulkheads, the pressures are to be calculated at a section located at $b_{tk}/2$ from the longitudinal bulkheads of each tank

(b) for longitudinal corrugated bulkheads, the pressures are to be calculated at the ends of the tank, i.e., the intersection of the forward and aft transverse bulkheads and the longitudinal bulkhead

b_{tk} : maximum breadth of tank under consideration measured at the bulkhead, in m

s_{cg} : spacing of corrugation, in mm . See **Fig. 8.2.3**

l_o : effective bending span of the corrugation, measured from the mid depth of the lower stool to the mid depth of the upper stool, or upper end where no upper stool is fitted, in m , see **Fig. 8.2.3**

l_{cg} : length of corrugation, which is defined as the distance between the lower stool and the upper stool or the upper end where no upper stool is fitted, in m , see **Fig. 8.2.3**

C_i : the relevant bending moment coefficients as given in **Table 8.2.3**

C_{s-cg} : permissible bending stress coefficient

at the mid length of the corrugation length, l_{cg}

= c_{es} , but not to be taken as greater than 0.75 for acceptance criteria set AC1

= c_{es} , but not to be taken as greater than 0.90 for acceptance criteria set AC2

at the lower and upper ends of corrugation length, l_{cg}

= 0.75 for acceptance criteria set AC1

= 0.90 for acceptance criteria set AC2

$$c_e = \frac{2.25}{\beta} - \frac{1.25}{\beta^2} \quad \text{for } \beta \geq 1.25$$

$$= 1.0 \quad \text{for } \beta < 1.25$$

$$\beta = \frac{b_f}{t_{f-net}} \sqrt{\frac{\sigma_{yd}}{E}}$$

b_f : breadth of flange plating, in mm , see **Fig. 8.2.3**

t_{f-net} : net thickness of the corrugation flange, in mm

E : modulus of elasticity, in N/mm^2

σ_{yd} : specified minimum yield stress of the material, in N/mm^2

Table 8.2.3 Values of C_i

Bulkhead	At lower end of l_{cg}	At mid length of l_{cg}	At upper end of l_{cg}
Transverse Bulkhead	C_1	C_{m1}	$0.65C_{m1}$
Longitudinal Bulkhead	C_3	C_{m3}	$0.65C_{m3}$

Where:

$$C_1 = a_1 + b_1 \sqrt{\frac{A_{dt}}{b_{dk}}} \quad \text{but is not to be taken as less than 0.60}$$

$$= a_1 - b_1 \sqrt{\frac{A_{dt}}{b_{dk}}} \quad \text{for transverse bulkhead with no lower stool, but is not to be taken as less than 0.55}$$

$$a_1 = 0.95 - \frac{0.41}{R_{bt}} = 1.0 \quad \text{for transverse bulkhead with no lower stool}$$

$$b_1 = -0.20 + \frac{0.078}{R_{bt}} = 0.13 \quad \text{for transverse bulkhead with no lower stool}$$

$$C_{m1} = a_{m1} + b_{m1} \sqrt{\frac{A_{dt}}{b_{dk}}} \quad \text{but is not to be taken as less than 0.55}$$

$$= a_{m1} - b_{m1} \sqrt{\frac{A_{dt}}{b_{dk}}} \quad \text{for transverse bulkhead with no lower stool, but is not to be taken as less than 0.60}$$

$$a_{m1} = 0.63 + \frac{0.25}{R_{bt}} = 0.85 \quad \text{for transverse bulkhead with no lower stool}$$

$$b_{m1} = -0.25 - \frac{0.11}{R_{bt}} = 0.34 \quad \text{for transverse bulkhead with no lower stool}$$

$$C_3 = a_3 + b_3 \sqrt{\frac{A_{dl}}{l_{dk}}} \quad \text{but is not to be taken as less than 0.60}$$

$$= a_3 - b_3 \sqrt{\frac{A_{dl}}{l_{dk}}} \quad \text{for longitudinal bulkhead with no lower stool, but is not to be taken as less than 0.55}$$

$$a_3 = 0.86 - \frac{0.35}{R_{bt}} = 1.0 \quad \text{for longitudinal bulkhead with no lower stool}$$

$$b_3 = -0.17 + \frac{0.10}{R_{bt}} = 0.13 \quad \text{for longitudinal bulkhead with no lower stool}$$

$$C_{m3} = a_{m3} + b_{m3} \sqrt{\frac{A_{dl}}{l_{dk}}} \quad \text{but is not to be taken as less than 0.55}$$

$$= a_{m3} - b_{m3} \sqrt{\frac{A_{dl}}{l_{dk}}} \quad \text{for longitudinal bulkhead with no lower stool, but is not to be taken as less than 0.60}$$

$$a_{m3} = 0.32 + \frac{0.24}{R_{bt}} = 0.85 \quad \text{for longitudinal bulkhead with no lower stool}$$

$$b_{m3} = -0.12 - \frac{0.10}{R_{bt}} = 0.19 \quad \text{for longitudinal bulkhead with no lower stool}$$

$$R_{bt} = \frac{A_{bt}}{b_{ib}} \left(1 + \frac{l_{ib}}{b_{ib}} \right) \left(1 + \frac{b_{av-l}}{h_{st}} \right) \quad \text{for transverse bulkheads}$$

$$R_{bl} = \frac{A_{bt}}{l_{ib}} \left(1 + \frac{l_{ib}}{b_{ib}} \right) \left(1 + \frac{b_{av-l}}{h_{st}} \right) \quad \text{for longitudinal bulkheads}$$

A_{dt} : cross sectional area enclosed by the moulded lines of the transverse bulkhead upper stool, in m^2
 = 0 if no upper stool is fitted

A_{dl} : cross sectional area enclosed by the moulded lines of the longitudinal bulkhead upper stool, in m^2

	= 0	if no upper stool is fitted
A_{bt}	:	cross sectional area enclosed by the moulded lines of the transverse bulkhead lower stool, in m^2
A_{bl}	:	cross sectional area enclosed by the moulded lines of the longitudinal bulkhead lower stool, in m^2
b_{av-t}	:	average width of transverse bulkhead lower stool, in m . See Fig. 8.2.3
b_{av-l}	:	average width of longitudinal bulkhead lower stool, in m . See Fig. 8.2.3
h_{st}	:	height of transverse bulkhead lower stool, in m . See Fig. 8.2.3
h_{sl}	:	height of longitudinal bulkhead lower stool, in m . See Fig. 8.2.3
b_{ib}	:	breadth of cargo tank at the inner bottom level between hopper tanks, or between the hopper tank and centreline lower stool, in m . See Fig. 8.2.3
b_{dk}	:	breadth of cargo tank at the deck level between upper wing tanks, or between the upper wing tank and centreline deck box or between the corrugation flanges if no upper stool is fitted, in m . See Fig. 8.2.3
l_{ib}	:	length of cargo tank at the inner bottom level between transverse lower stools, in m . See Fig. 8.2.3
l_{dk}	:	length of cargo tank at the deck level between transverse upper stools or between the corrugation flanges if no upper stool is fitted, in m . See Fig. 8.2.3

2.5.7.7 For tanks with effective sloshing breadth, b_{slh} , greater than $0.56B$ or effective sloshing length l_{slh} , greater than $0.13L_{CSR-T}$, additional sloshing analysis is to be carried out to assess the section modulus of the unit corrugation in accordance with the requirements of the Society.

2.5.7.8 For ships with a moulded depth, see **Section 4/1.1.4**, equal to or greater than $16m$, a lower stool is to be fitted in compliance with the following requirements:

- (a) general:
 - the height and depth are not to be less than the depth of the corrugation
 - the lower stool is to be fitted in line with the double bottom floors or girders
 - the side stiffeners and vertical webs (diaphragms) within the stool structure are to align with the structure below, as far as is practicable, to provide appropriate load transmission to structures within the double bottom.
- (b) stool top plating:
 - the net thickness of the stool top plate is not to be less than that required for the attached corrugated bulkhead and is to be of at least the same material yield strength as the attached corrugation
 - the extension of the top plate beyond the corrugation is not to be less than the as-built flange thickness of the corrugation.
- (c) stool side plating and internal structure:
 - within the region of the corrugation depth from the stool top plate the net thickness of the stool side plate is not to be less than 90% of that required by **2.5.7.2** for the corrugated bulkhead flange at the lower end and is to be of at least the same material yield strength
 - the net thickness of the stool side plating and the net section modulus of the stool side stiffeners is not to be less than that required by **2.5.2**, **2.5.4** and **2.5.5** for transverse or longitudinal bulkhead plating and stiffeners
 - the ends of stool side vertical stiffeners are to be attached to brackets at the upper and lower ends of the stool
 - continuity is to be maintained, as far as practicable, between the corrugation web and supporting brackets inside the stool. The bracket net thickness is not to be less than 80% of the required thickness of the corrugation webs and is to be of at least the same material yield strength
 - scallops in the diaphragms in way of the connections of the stool sides to the inner bottom and to the stool top plate are not permitted.

2.5.7.9 For ships with a moulded depth, see **Section 4/1.1.4**, less than $16m$, the lower stool may be eliminated provided the following requirements, in addition to the requirements of **2.5.7.6**, are complied with:

- (a) general:
 - double bottom floors or girders are to be fitted in line with the corrugation flanges for transverse or longitudinal bulkheads, respectively
 - brackets/carlings are to be fitted below the inner bottom and hopper tank in line with corrugation webs. Where this is not practicable gusset plates with shedder plates are to be fitted, see item (c) below and **Fig. 8.2.3**

- the corrugated bulkhead and its supporting structure is to be assessed by Finite Element (FE) analysis in accordance with **Section 9/2**. In addition the local scantlings requirements of **2.5.6.4** and **2.5.6.5** and the minimum corrugation depth requirement of **2.5.7.4** are to be applied.
- (b) inner bottom and hopper tank plating:
- the inner bottom and hopper tank in way of the corrugation is to be of at least the same material yield strength as the attached corrugation, and 'Z' grade steels as given in **Section 6/1.1.5** are to be used unless plate through thickness properties are documented for approval.
- (c) supporting structure:
- within the region of the corrugation depth below the inner bottom the net thickness of the supporting double bottom floors or girders is not to be less than the net thickness of the corrugated bulkhead flange at the lower end and is to be of at least the same material yield strength
 - the upper ends of vertical stiffeners on supporting double bottom floors or girders are to be bracketed to adjacent structure
 - brackets/carlings arranged in line with the corrugation web are to have a depth of not less than 0.5 times the corrugation depth and a net thickness not less than 80% of the net thickness of the corrugation webs and are to be of at least the same material yield strength
 - cut outs for stiffeners in way of supporting double bottom floors and girders in line with corrugation flanges are to be fitted with full collar plates
 - where support is provided by gussets with shedder plates, the height of the gusset plate, see h_g in **Fig. 8.2.3**, is to be at least equal to the corrugation depth, and gussets with shedder plates are to be arranged in every corrugation. The gusset plates are to be fitted in line with and between the corrugation flanges. The net thickness of the gusset and shedder plates are not to be less than 100% and 80%, respectively, of the net thickness of the corrugation flanges and are to be of at least the same material yield strength. Also see **2.5.7.11**.
 - scallops in brackets, gusset plates and shedder plates in way of the connections to the inner bottom or corrugation flange and web are not permitted.
- 2.5.7.10 In general, an upper stool is to be fitted in compliance with the following requirements:
- (a) general:
- where no upper stool is fitted, finite element analysis is to be carried out to demonstrate the adequacy of the details and arrangements of the bulkhead support structure to the upper deck structure
 - side stiffeners and vertical webs (diaphragms) within the stool structure are to align with adjoining structure to provide for appropriate load transmission
 - brackets are to be arranged in the intersections between the upper stool and the structure on deck
- (b) stool bottom plating:
- the net thickness of the stool bottom plate is not to be less than that required for the attached corrugated bulkhead and is to be of at least the same material yield strength as the attached corrugation
 - the extension of the bottom plate beyond the corrugation is not to be less than the attached as-built flange thickness of the corrugation.
- (c) stool side plating and internal structure:
- within the region of the corrugation depth above the stool bottom plate the net thickness of the stool side plate is to be not less than 80% of that required by **2.5.7.2** for the corrugated bulkhead flange at the upper end where the same material is used. If material of different yield strength is used the required thickness is to be adjusted by the ratio of the two material factors (k). k is defined in **Section 6/1.1.4.1**
 - the net thickness of the stool side plating and the net section modulus of the stool side stiffeners is not to be less than that required by **2.5.2**, **2.5.4** and **2.5.5** for the transverse or longitudinal bulkhead plating and stiffeners
 - the ends of stool side vertical stiffeners are to be attached to brackets at the upper and lower ends of the stool
 - scallops in the diaphragms in way of the connections of the stool sides to the deck and to the stool bottom plate are not permitted.

2.5.7.11 Where gussets with shedder plates or shedder plates (slanting plates) are fitted at the end connection of the corrugation to the lower stool or to the inner bottom, appropriate means are to be provided to prevent the possibility of gas pockets being formed by these plates.

2.5.7.12 Welding for all connections and joints is to comply with **Section 6/5**.

2.5.8 Non-tight bulkheads

2.5.8.1 Non-tight bulkheads (wash bulkheads), where fitted, are to be in line with transverse webs, bulkheads or similar structures. They are to be of plane construction, horizontally or vertically stiffened, and are to comply with the sloshing requirements given in **6.2**. In general, openings in the non-tight bulkheads are to have generous radii and their aggregate area is not to be less than 10% of the area of the bulkhead.

Fig. 8.2.3 Definition of Parameters for Corrugated Bulkhead (Tankers with Longitudinal Bulkhead at Centreline)

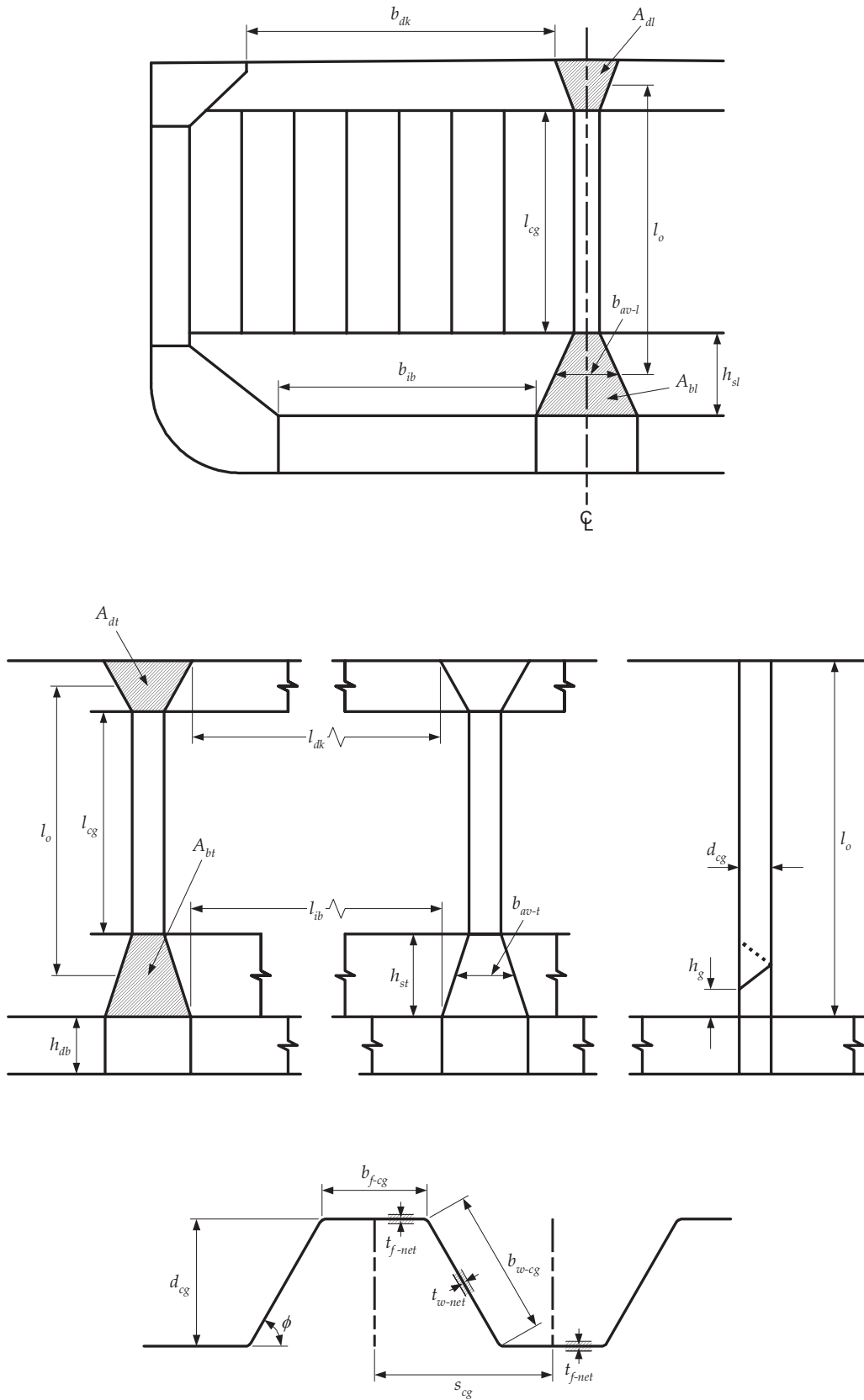

Table 8.2.4 Thickness Requirements for Plating

The minimum net thickness, t_{nets} is to be taken as the greatest value for all applicable design load sets, as given in **Table 8.2.7**, and given by:

$$t_{net} = 0.0158 \alpha_p s \sqrt{\frac{|P|}{C_a \sigma_{yd}}} \quad (mm)$$

Where:

P : design pressure for the design load set being considered and calculated at the load calculation point defined in **Section 3/5.1**, in kN/m^2

α_p : correction factor for the panel aspect ratio
 $= 1.2 - \frac{s}{2100l_p}$ but is not to be taken as greater than 1.0

s : as defined in **Section 4/2.2**, in mm

l_p : length of plate panel, to be taken as the spacing of primary support members, S , unless carlings are fitted, in m

σ_{yd} : specified minimum yield stress of the material, in N/mm^2

C_a : permissible bending stress coefficient for the design load set being considered

$$= \beta_a - \alpha_a \frac{|\sigma_{hg}|}{\sigma_{yd}} \quad \text{but not to be taken greater than } C_{a-max}$$

Acceptance Criteria Set	Structural Member		β_a	α_a	C_{a-max}
AC1	Longitudinal Strength Members	Longitudinally stiffened plating	0.9	0.5	0.8
		Transversely or vertically stiffened plating	0.9	1.0	0.8
	Other members		0.8	0	0.8
AC2	Longitudinal Strength Members	Longitudinally stiffened plating	1.05	0.5	0.95
		Transversely or vertically stiffened plating	1.05	1.0	0.95
	Other members, including watertight boundary plating		1.0	0	1.0

σ_{hg} : hull girder bending stress for the design load set being considered and calculated at the load calculation point defined in **Section 3/5.1.2**

$$= \left(\frac{(z - z_{NA-net50}) M_{v-total}}{I_{v-net50}} - \frac{y M_{h-total}}{I_{h-net50}} \right) 10^{-3} \quad (N/mm^2)$$

$M_{v-total}$: design vertical bending moment at the longitudinal position under consideration for the design load set being considered, in kNm . The still water bending moment, $M_{sw-perm}$ is to be taken with the same sign as the simultaneously acting wave bending moment, M_{wv} , see **Table 7.6.1**

$M_{h-total}$: design horizontal bending moment at the longitudinal position under consideration for the design load set being considered, in kNm

$I_{v-net50}$: net vertical hull girder moment of inertia, at the longitudinal position being considered, as defined in **Section 4/2.6.1**, in m^4

$I_{h-net50}$: net horizontal hull girder moment of inertia, at the longitudinal position being considered, as defined in **Section 4/2.6.2**, in m^4

y : transverse coordinate of load calculation point, in m

z : vertical coordinate of the load calculation point under consideration, in m

$z_{NA-net50}$: distance from the baseline to the horizontal neutral axis, as defined in **Section 4/2.6.1**, in m

Table 8.2.5 Section Modulus Requirements for Stiffeners

The minimum net section modulus, Z_{nets} is to be taken as the greatest value calculated for all applicable design load sets, as given in **Table 8.2.7**, and given by:

$$Z_{net} = \frac{|P|_s l_{bdg}^2}{f_{bdg} C_s \sigma_{yd}} \quad (cm^3)$$

Where:

- P : design pressure for the design load set being considered and calculated at the load calculation point defined in **Section 3/5.2**, in kN/m^2
- f_{bdg} : bending moment factor for continuous stiffeners and where end connections are fitted consistent with idealisation of the stiffener as having as fixed ends
= 12 for horizontal stiffeners
= 10 for vertical stiffeners
for stiffeners with reduced end fixity see **Sub-section 7**.
- l_{bdg} : effective bending span, in m , as defined in **Section 4/2.1.1**
- s : as defined in **Section 4/2.2**, in mm
- σ_{yd} : specified minimum yield stress of the material, see also **Section 3/5.2.6.5**, in N/mm^2
- C_s : permissible bending stress coefficient for the design load set being considered, to be taken as

Sign of Hull Girder Bending Stress, σ_{hg}	Side Pressure Acting On	Acceptance Criteria
Tension (+ve)	Stiffener side	$C_s = \beta_s - \alpha_s \frac{ \sigma_{hg} }{\sigma_{yd}}$ but not to be taken greater than C_{s-max}
Compression (-ve)	Plate side	
Tension (+ve)	Plate side	$C_s = C_{s-max}$
Compression (-ve)	Stiffener side	

Acceptance Criteria Set	Structural Member	β_s	α_s	C_{s-max}
AC1	Longitudinal strength member	0.85	1.0	0.75
	Transverse or vertical member	0.75	0	0.75
AC2	Longitudinal strength member	1.0	1.0	0.9
	Transverse or vertical member	0.9	0	0.9
	Watertight boundary Stiffeners	0.9	0	0.9

σ_{hg} : hull girder bending stress for the design load set being considered and calculated at the reference point defined in **Section 3/5.2.2.5**

$$= \left(\frac{(z - z_{NA-net50}) M_{v-total}}{I_{v-net50}} - \frac{y M_{h-total}}{I_{h-net50}} \right) 10^{-3} \quad (N/mm^2)$$

$M_{v-total}$: design vertical bending moment at longitudinal position under consideration for the design load set being considered, in kNm .

$M_{v-total}$ is to be calculated in accordance with **Table 7.6.1** using the permissible hogging or sagging still water bending moment, $M_{sw-perm}$, to be taken as

Stiffener Location	$M_{sw-perm}$	
	Pressure acting on Plate Side	Pressure acting on Stiffener Side
Above Neutral Axis	Sagging SWBM	Hogging SWBM
Below Neutral Axis	Hogging SWBM	Sagging SWBM

$M_{h-total}$: design horizontal bending moment at longitudinal position under consideration for the design load set being considered, see **Table 7.6.1**, in kNm

$I_{v-net50}$: net vertical hull girder moment of inertia, at the longitudinal position being considered, as defined in **Section 4/2.6.1**, in m^4

$I_{h-net50}$: net horizontal hull girder moment of inertia, at the longitudinal position being considered, as defined in **Section 4/2.6.2**, in m^4

y : transverse coordinate of the reference point defined in **Section 3/5.2.2.5**, in m

z : vertical coordinate of the reference point defined in **Section 3/5.2.2.5**, in m

$z_{NA-net50}$: distance from the baseline to the horizontal neutral axis, as defined in **Section 4/2.6.1**, in m

Table 8.2.6 Web Thickness Requirements for Stiffeners

The minimum net web thickness, t_{w-net} , is to be taken as the greatest value calculated for all applicable design load sets, as given in **Table 8.2.7**, and given by:

$$t_{w-net} = \frac{f_{shr} |P| s l_{shr}}{d_{shr} C_t \tau_{yd}} \quad (mm)$$

Where:

P : design pressure for the design load set being considered and calculated at the load calculation point defined in **Section 3/5.1**, in kN/m^2

f_{shr} : shear force distribution factor
for continuous stiffeners and where end connections are fitted consistent with idealisation of the stiffener as having as fixed ends
= 0.5 for horizontal stiffeners
= 0.7 for vertical stiffeners
for stiffeners with reduced end fixity, see **Sub-section 7**

d_{shr} : as defined in **Section 4/2.4.2.2**, in mm

C_t : permissible shear stress coefficient for the design load set being considered, to be taken as
= 0.75 for acceptance criteria set AC1
= 0.90 for acceptance criteria set AC2

s : as defined in **Section 4/2.2**, in mm

l_{shr} : effective shear span, in m , see **Section 4/2.1.2**

$\tau_{yd} = \frac{\sigma_{yd}}{\sqrt{3}} \quad N/mm^2$

σ_{yd} : specified minimum yield stress of the material, in N/mm^2

Table 8.2.7 Design Load Sets for Plating and Local Support Members

Structural Member		Design Load Set ^(1,2,3)	Load Component	Draught	Comment	Diagrammatic Representation		
Keel, Bottom Shell, Bilge, Side Shell, Sheer strake		1	P_{ex}	T_{sc}	Sea pressure only			
		2	P_{ex}	T_{sc}				
		7	$P_{in} - P_{ex}$	T_{bal}	Net pressure difference between water ballast pressure and sea pressure			
		8	$P_{in} - P_{ex}$	$0.25T_{sc}$				
Deck	In way of cargo tanks	1	P_{ex}	T_{sc}	Green sea pressure only or other loads on deck			
		3	P_{in}	$0.6T_{sc}$	Cargo pressure only			
		4	P_{in}	-				
		11	$P_{in-flood}$	-				
	In way of other tanks	1	P_{ex}	T_{sc}	Green sea pressure only or other loads on deck			
		5	P_{in}	T_{bal}	Water ballast or other liquid pressure only			
		6	P_{in}	$0.25T_{sc}$				
		11	$P_{in-flood}$	-				
	Any location	9	P_{dk}	T_{bal}	Distributed or concentrated loads only. Simultaneously occurring green sea pressure may be ignored			
		10	P_{dk}	-				
	Inner Bottom, Inner hull, Hopper side		3	P_{in}	$0.6T_{sc}$	Cargo pressure only		
			4	P_{in}	-			
5			P_{in}	T_{bal}	Water ballast or other liquid pressure only			
6			P_{in}	$0.25T_{sc}$				
11			$P_{in-flood}$	-				
Longitudinal Bulkhead, Centreline Bulkhead		3	P_{in}	$0.6T_{sc}$	Pressure from one side only. Full cargo tank with adjacent cargo tank empty.			
		4	P_{in}	-				
		11	$P_{in-flood}$	-	Two cases are to be evaluated: 1. Inner empty, outer full 2. Inner full, outer empty			

Table 8.2.7 (Continued) Design Load Sets for Plating and Local Support Members

Structural Member		Design Load Set ^(1, 2, 3)	Load Component	Draught	Comment	Diagrammatic Representation
Transverse Bulkhead	In way of cargo tanks	3	P_{in}	$0.6T_{sc}$	Pressure from one side only. Full cargo tank with adjacent fwd or aft cargo tank empty. Need to evaluate 2 cases 1) Fwd empty, aft full 2) Fwd full, aft empty	
		4	P_{in}	-		
		11	$P_{in-flood}$	-		
	In way of other tanks	5	P_{in}	T_{bal}		
		6	P_{in}	$0.25T_{sc}$		
		11	$P_{in-flood}$	-		
Other tank boundaries, e.g. Girders, Floors, Stringers	5	P_{in}	T_{bal}	Pressure from one side only. Full tank with adjacent tank empty. Need to evaluate 2 cases, see above		
	6	P_{in}	$0.25T_{sc}$			
	11	$P_{in-flood}$	-			

Where:

T_{sc} : scantling draught, in m , as defined in **Section 4/1.1.5.5**

T_{bal} : minimum design ballast draught, in m , as defined in **Section 4/1.1.5.2**

Notes

1. Specification of design load combination, load component, acceptance criteria and other load parameters for each design load set are given in **Table 8.2.8**
2. When the ship's configuration cannot be described by the above, then the applicable Design Load Sets to determine the scantling requirements of structural boundaries are to be selected so as to specify a full tank on one side with the adjacent tank or space empty. The boundary is to be evaluated for loading from both sides. Design Load Sets are to be selected based on the tank or space contents and are to maximise the pressure on the structural boundary, the draught to use is to be taken in accordance with the Design Load Set and this table. Design Load Sets covering the S and S+D design load combinations are to be selected. See **Note 4** and **Table 8.2.8**.
3. The boundaries of void and dry space not forming part of the hull envelope are to be evaluated using Design Load Set 11. See **Note 2**.
4. Design load sets (DLS) for some structural members not covered by the above:
 - For the boundaries of a stool water ballast tank with the cargo tank:
 - DLSs 5, 6 and 11 are to be applied for pressure from the WB tank side
 - DLSs 3, 4 and 11 for pressure from the cargo tank side
 - For a double bottom girder separating two water ballast tanks or separating a water ballast and fuel oil tank:
 - DLSs 5, 6 and 11 are to be applied for pressure from each side in turn
 - For the boundary of a stool void space to the cargo tank:
 - DLSs 3, 4 and 11 for pressure from the cargo tank side
 - DLS 11 for pressure from the void space side

Table 8.2.8 Specification of Design Load Combination, Acceptance Criteria and other Load Parameters for each Design Load Set

Design Load Set	Load Component ⁽¹⁾	Design Load Combination ⁽²⁾	Acceptance Criteria Set	Parameters for Calculating Load Components		
				<i>DLCF</i> ⁽³⁾	<i>GM</i>	<i>r_{roll-gvr}</i>
Hull envelope (<i>PSM</i> and <i>LSM</i>)						
1	Sea pressures P_{ex}	<i>S+D</i>	AC2	Loaded <i>DLCF</i>	0.12 <i>B</i>	0.35 <i>B</i>
2		<i>S</i>	AC1			
Cargo tank boundaries (<i>PSM</i> and <i>LSM</i>)						
3	Cargo pressures P_{in}	<i>S+D</i>	AC2	Loaded <i>DLCF</i>	0.24 <i>B</i>	0.40 <i>B</i>
4		<i>S</i>	AC1			
Boundaries of water ballast and other tanks (<i>PSM</i> and <i>LSM</i>)						
5	Water ballast or other liquid tank pressures P_{in}	<i>S+D</i>	AC2	Ballast <i>DLCF</i>	0.33 <i>B</i>	0.45 <i>B</i>
6		<i>S</i>	AC1			
7	Net water ballast minus sea pressures $P_{in} - P_{ex}$	<i>S+D</i>	AC2	Ballast <i>DLCF</i>	0.33 <i>B</i>	0.45 <i>B</i>
8		<i>S</i>	AC1			
Decks (<i>LSM</i> and <i>PSM</i>)						
9	Distributed and concentrated loads on deck P_{dk}	<i>S+D</i>	AC2	Ballast <i>DLCF</i>	0.33 <i>B</i>	0.45 <i>B</i>
10		<i>S</i>	AC1			
Watertight boundaries (<i>LSM</i> and <i>PSM</i>)						
11	Accidental flooding $P_{in-flood}$	<i>A</i>	AC2			
Hull envelope (<i>PSM</i>)						
12	Net cargo pressure minus sea pressure $P_{in} - P_{ex}$	<i>S+D</i>	AC2	Loaded <i>DLCF</i>	0.24 <i>B</i>	0.40 <i>B</i>
13		<i>S</i>	AC1			
14	Average cargo and sea pressure $(P_{in} + P_{ex})/2$	<i>S+D</i>	AC2	Loaded <i>DLCF</i>	0.12 <i>B</i>	0.35 <i>B</i>
15		<i>S+D</i>	AC2	Loaded <i>DLCF</i>	0.24 <i>B</i>	0.40 <i>B</i>
16		<i>S</i>	AC1			

Where:

PSM : Primary Support Members

LSM : Local Support Members

DLCF : Dynamic Load Combination Factors

P_{in} P_{ex} P_{dk} $P_{in-flood}$: as given in **Table 7.6.1** and as shown in **Table 8.2.7** or **Table 8.2.9**

B : moulded breadth, in *m*, as defined in **Section 4/1.1.3.1**

Notes

- Structural members are to be designed using all design load sets which are applicable. This table gives the pressure load component of the design load set. The hull girder bending moments are given in **Tables 8.2.4** and **8.2.5** for local support members.
- This column specifies which column in the design load combination table is to be applied for each design load set, see **Table 7.6.1**. Where *S* denotes the static design load combination, *S+D* denotes the static plus dynamic design load combination and *A* denotes the accidental design load combination.
- This column specifies which dynamic load combination factor table is to be used for the deviation of the pressure components and global load components, see **Table 7.6.1**

2.6 Primary Support Members

2.6.1 General

2.6.1.1 The scantlings of the primary support members in the cargo tank region for the extents shown in **Fig. 8.2.4** are to be in accordance with the requirements of **2.6.1.2** to **2.6.1.7**.

2.6.1.2 The section modulus and shear area criteria for primary support members contained in 2.6 apply to structural configurations shown in Fig. 2.3.1 and are applicable to the following structural elements:

- floors and girders within the double bottom;
- deck transverses fitted below the upper deck;
- side transverses within double side structure;
- vertical web frames on longitudinal bulkheads with or without cross ties;
- horizontal stringers on transverse bulkheads, except those fitted with buttresses or other intermediate supports; and
- cross ties in wing cargo and centre cargo tanks.

2.6.1.3 The scantlings of primary support members are to be verified by the Finite Element (FE) cargo tank structural analysis defined in Section 9/2.

2.6.1.4 The section modulus and/or shear area of a primary support member and/or the cross sectional area of a primary support member cross tie may be reduced to 85% of the prescriptive requirements provided that the reduced scantlings comply with the FE cargo tank structural analysis and with 2.1.6.

2.6.1.5 In general, primary support members are to be arranged in one plane to form continuous transverse rings. Brackets forming connections between primary support members of the ring are to be designed in accordance with Section 4/3.3.3.

2.6.1.6 Webs of the primary support members are to be stiffened in accordance with Section 10/2.3.

2.6.1.7 Webs of the primary support members are to have a depth of not less than given by the requirements of 2.6.4.1, 2.6.6.1 and 2.6.7.1, as applicable. Lesser depths may be accepted where equivalent stiffness is demonstrated. See 3/5.3.3.4. Primary support members that have open slots for stiffeners are to have a depth not less than 2.5 times the depth of the slots.

2.6.1.8 The scantlings of the first primary support members from the transverse bulkhead are to be in accordance with Section 8/7, 2.6.1.3, 2.6.1.4, 2.6.1.5, 2.6.1.6, 2.6.4.3 and 2.6.4.4. In the application of 2.6.4.3 and 2.6.4.4 only the design green sea pressure is to be considered.

Fig. 8.2.4 Depiction of Applicable Extents

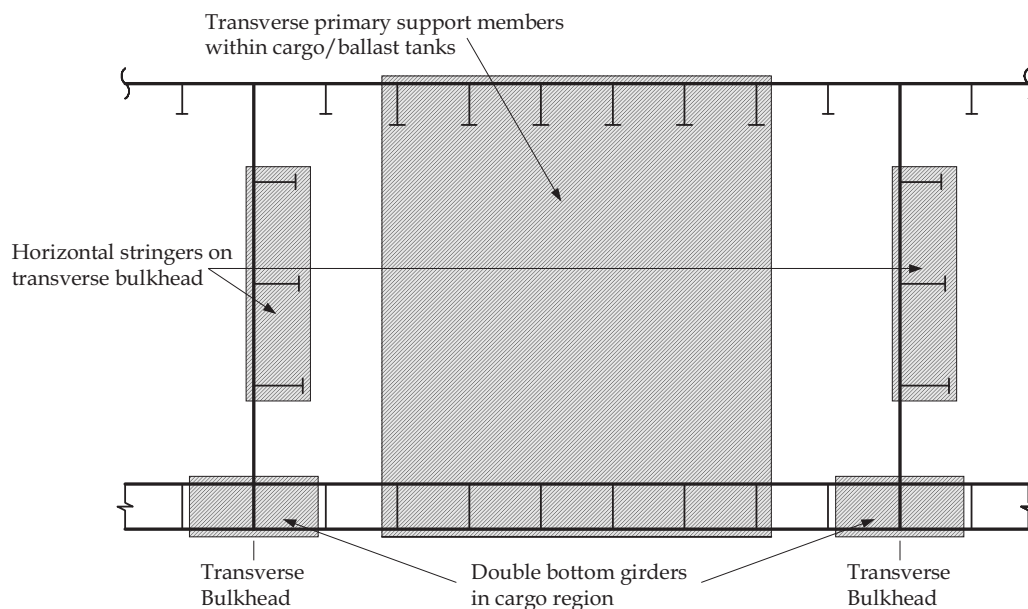

2.6.2 Design load sets and permissible stress coefficients for primary support members

2.6.2.1 The design load sets for the evaluation of the primary support members are given in Table 8.2.9.

2.6.2.2 The permissible bending and shear stress coefficients for the evaluation of the primary support members are given in Table 8.2.10.

Table 8.2.9 Design Load Sets for Primary Support Members

Structural Member	Design Load Set (1, 5, 6)	Load Component	Draught	Comment	Diagrammatic Representation
Double bottom floors and girders ⁽³⁾	1	P_{ex}	$0.9T_{sc}$ ⁽²⁾	Sea pressure only	
	2	P_{ex}	T_{sc}		
	12	$P_{in} - P_{ex}$	$0.6T_{sc}$	Net pressure difference between cargo pressure and sea pressure	
	13	$P_{in} - P_{ex}$	⁽⁴⁾		
Side transverses ⁽³⁾	1	P_{ex}	$0.9T_{sc}$	Sea pressure only	
	2	P_{ex}	T_{sc}		
	3	P_{in}	$0.6T_{sc}$	Cargo pressure only	
	4	P_{in}	-		
Deck transverses	1	P_{ex}	T_{sc}	Green sea pressure only or other loads on deck	
	3	P_{in}	$0.6T_{sc}$	Cargo pressure only	
	4	P_{in}	-		
Vertical web frames on longitudinal bulkheads	3	P_{in}	$0.6T_{sc}$	Pressure from one side only. Full cargo tank with adjacent cargo tank empty	
	4	P_{in}	-		
	3	P_{in}	$0.6T_{sc}$	Pressure from one side only. Full cargo tank with adjacent cargo tank empty	
	4	P_{in}	-		
Horizontal stringers on transverse bulkhead	3	P_{in}	$0.6T_{sc}$	Pressure from one side only. Full cargo tank with adjacent forward or aft cargo tank empty. Two cases are to be evaluated: 1. forward empty/aft full 2. forward full/aft empty	
	4	P_{in}	-		
	11	$P_{in-flood}$	-		
Cross ties in centre tanks	3	$\frac{P_{in-pt} + P_{in-stb}}{2}$	$0.6T_{sc}$	Full wing cargo tanks, centre tank empty.	
	4	P_{in}	-		
Cross ties in wing tanks	14	$\frac{P_{in} + P_{ex}}{2}$	T_{sc}	Full centre tank, wing cargo tanks empty.	
	15	$\frac{P_{in} + P_{ex}}{2}$	$0.6T_{sc}$		
	16	$\frac{P_{in} + P_{ex}}{2}$	T_{sc}		

Where:

P_{in-pt} : design pressure from port side wing cargo tank, in kN/m^2

P_{in-stb} : design pressure from starboard side wing cargo tank, in kN/m^2

T_{sc} : scantling draught, in m , as defined in **Section 4/1.1.5.5**

T_{bal} : minimum design ballast draught, in m , as defined in **Section 4/1.1.5.2**

Table 8.2.9 (Continued) Design Load Sets for Primary Support Members

Notes

1. Specification of design load combination, load component, acceptance criteria set and other load parameters for each design load set are given in **Table 8.2.8**.
2. See **1.1.2.9(b)**
3. Draughts specified for bottom floors, girders and side transverses are based on operational limits specified in **1.1.2**. Where the optional loading conditions exceed the minimum Rule required loading conditions the draughts will be subject to special consideration.
4. For tankers with two oil-tight longitudinal bulkheads, the draught is to be taken as $0.25T_{sc}$. For tankers with a centreline bulkhead, the draught is to be taken as $0.33T_{sc}$.
5. When the ship's configuration cannot be described by the structural members or structural configurations identified above, then the applicable Design Load Sets to determine the scantling requirements of primary support member are to be selected so as to specify all applicable cases from the following:
 - a full tank on one side of the member with the tank or space on the other side empty
 - a full tank on one side of the member with the external pressure minimised
 - external pressure maximised with the adjacent tank or space empty
 The boundary is to be evaluated for loading from both sides. Design Load Sets are to be selected based on the tank or space contents and are to maximise the net pressure on the structural boundary, the draught to use is to be taken in accordance with the Design Load Set and this table. Design Load Sets covering the S and S+D design load combinations are to be selected. Design Load Set 11 may also need to be applied, depending on the particular structural configuration. See **Note 4** on **Table 8.2.7** and **Table 8.2.8**.
6. For a void or dry space, the pressure component from the void side is to be ignored, except where Design Load Set 11 needs to be applied.

 Table 8.2.10 Permissible Stress Coefficients, C_{s-pr} and C_{t-pr} , for Primary Support Members

Acceptance criteria set	Permissible bending stress coefficient, C_{s-pr}	Permissible shear stress coefficient, C_{t-pr}
AC1	0.70	0.70
AC2	0.85	0.85

2.6.3 Floors and girders in double bottom

2.6.3.1 Continuous double bottom girders are to be arranged at the centreline or duct keel, at the hopper side and in way of longitudinal bulkheads and bulkhead stools. Plate floors are to be arranged in way of transverse bulkheads and bulkhead stools.

2.6.3.2 The net shear area, $A_{shr-net50}$, of the floors at any position in the floor is not to be less than:

$$A_{shr-net50} = \frac{10Q}{C_{t-pr} \tau_{yd}} \quad (cm^2)$$

Where:

Q : design shear force
 $= f_{shr} P S l_{shr} \quad (kN)$

f_{shr} : shear force distribution factor
 $= f_{shr-i} \left(1 - \frac{2y_i}{l_{shr}} \right)$ but not to be taken as less than 0.2

f_{shr-i} : shear force distribution factor at the end of the span, l_{shr} , as given in **Table 8.2.11**

l_{shr} : effective shear span, of the double bottom floor, in m , as shown in **Fig. 8.2.6**. In way of bracket ends, the effective shear span is

measured to the toes of the effective end bracket, as defined in **Section 4/2.1.5**. Where the floor ends on a girder at a hopper or stool structure, the effective shear span is measured to a point that is one-half of the distance from the girder to the adjacent bottom and inner-bottom longitudinal, as shown in **Fig. 8.2.6**.

- y_i : distance from the considered cross-section of the floor to the nearest end of the effective shear span, l_{shr} , in m
- S : primary support member spacing, in m , as defined in **Section 4/2.2.2**
- P : design pressure for the design load set being considered, calculated at mid point of effective shear span, l_{shr} , of a floor located midway between transverse bulkheads or transverse bulkhead and wash bulkhead, where fitted, in kN/m^2
- C_{t-pr} : permissible shear stress coefficient for primary support member as given in **Table 8.2.10**
- $\tau_{yd} = \frac{\sigma_{yd}}{\sqrt{3}} \quad (N/mm^2)$
- σ_{yd} : specified minimum yield stress of the material, in N/mm^2

Table 8.2.11 Shear Force Distribution Factors of Floors

Structural Configuration	Centre tank (f_{shr3} in Fig. 8.2.5)	Wing Tank	
		At inboard end (f_{shr2} in Fig. 8.2.5)	At hopper knuckle end (f_{shr1} in Fig. 8.2.5)
Ships with centreline longitudinal bulkhead	-	0.4	0.6
Ships with two longitudinal bulkheads	0.5	0.50	0.65

Fig. 8.2.5 Floor Shear Force Distribution Factors of Floors

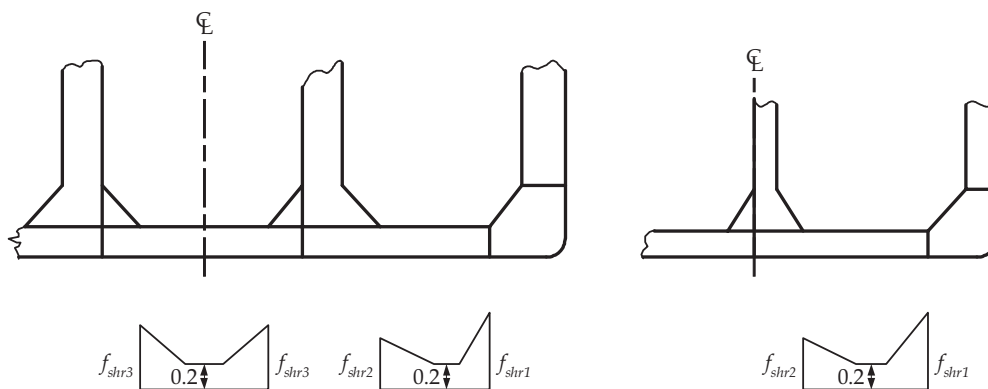
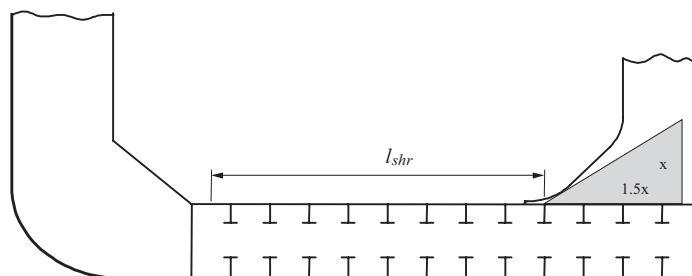
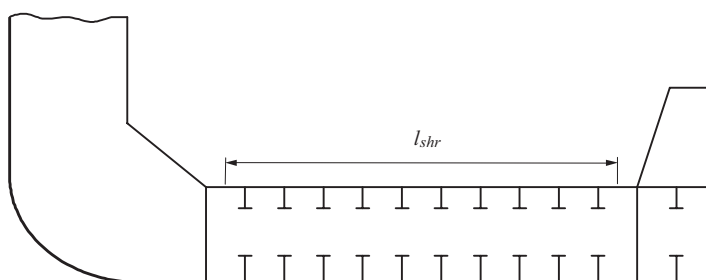

Fig. 8.2.6 Effective Shear Span of Floors



Typical arrangement with hopper and end bracket



Typical arrangement with hopper and stool

2.6.3.3 For double bottom centre girders where no longitudinal bulkhead is fitted above, the net shear area, $A_{shr-net50}$, of the double bottom centre girder in way of the first bay from each transverse bulkhead and wash bulkhead, where fitted, is not to be less than:

$$A_{shr-net50} = \frac{10Q}{C_{t-pr} \tau_{ydl}} \quad (cm^2)$$

Where:

Q : design shear force
 $= 0.21n_1n_2Pl_{shr}^2 \quad kN$

l_{shr} : effective shear span, of the double bottom floor, in m , as shown in **Fig. 8.2.6**. In way of bracket ends, the effective shear span is measured to the toes of the effective end bracket, as defined in **Section 4/2.1.5**. Where the floor ends on a girder at a hopper or stool structure, the effective shear span is measured to a point that is one-half of the distance from the girder to the adjacent bottom and inner-bottom longitudinal, as shown in **Fig. 8.2.6**.

P : design pressure for the design load set being considered, calculated at mid point of effective shear span, l_{shr} , of a floor located midway between transverse bulkheads or transverse bulkhead and wash bulkhead, where fitted, in kN/m^2

$$n_1 = 0.00935 \left(\frac{l_{shr}}{S} \right)^2 - 0.163 \left(\frac{l_{shr}}{S} \right) + 1.289$$

$$n_2 = 1.3 - \left(\frac{S}{12} \right)$$

S : double bottom floor spacing, in m , as defined in **Section 4/2.2.2**

C_{t-pr} : permissible shear stress coefficient for primary support member as

given in **Table 8.2.10**

$$\tau_{yd} = \frac{\sigma_{yd}}{\sqrt{3}} \quad (N/mm^2)$$

σ_{yd} : specified minimum yield stress of the material, in N/mm^2

2.6.3.4 For double bottom side girders where no longitudinal bulkhead is fitted above, the net shear area, $A_{shr-net50}$, of the double bottom side girder in way of the first bay from each transverse bulkhead and wash bulkhead, where fitted, is not to be less than:

$$A_{shr-net50} = \frac{10Q}{C_{t-pr} \tau_{yd}} \quad (cm^2)$$

Where:

Q : design shear force
 $= 0.14 n_3 n_4 P l_{shr}^2 \quad (kN)$

$n_3 = 1.072 - 0.0357 \left(\frac{l_{shr}}{S} \right)$

$n_4 = 1.2 - \left(\frac{S}{18} \right)$

l_{shr} : effective shear span, of the double bottom floor, in m , as shown in **Fig. 8.2.6**. In way of bracket ends, the effective shear span is measured to the toes of the effective end bracket, as defined in **Section 4/2.1.5**. Where the floor ends on a girder at a hopper or stool structure, the effective shear span is measured to a point that is one-half of the distance from the girder to the adjacent bottom and inner-bottom longitudinal, as shown in **Fig. 8.2.6**.

S : double bottom floor spacing, in m , as defined in **Section 4/2.2.2**

P : design pressure for the design load set being considered, calculated at mid point of effective shear span, l_{shr} , of a floor located midway between transverse bulkheads or transverse bulkhead and wash bulkhead, where fitted, in kN/m^2

C_{t-pr} : permissible shear stress coefficient for primary support member as given in **Table 8.2.10**

$$\tau_{yd} = \frac{\sigma_{yd}}{\sqrt{3}} \quad (N/mm^2)$$

σ_{yd} : specified minimum yield stress of the material, in N/mm^2

2.6.4 Deck transverses

2.6.4.1 The web depth of deck transverses is not to be less than:

- $0.20 l_{bdg-dt}$ for deck transverses in the wing cargo tanks of ships with two longitudinal bulkheads
- $0.13 l_{bdg-dt}$ for deck transverses in the centre cargo tanks of ships with two longitudinal bulkheads. The web depth of deck transverses in the centre cargo tank is not to be less than 90% of that of the deck transverses in the wing cargo tank
- $0.10 l_{bdg-dt}$ for the deck transverses of ships with a centreline longitudinal bulkhead.
- See also **2.6.1.7**

Where:

l_{bdg-dt} : effective bending span of the deck transverse, in m , see **Section 4/2.1.4** and **Fig. 8.2.7**, but is not to be taken as less than 60% of the breadth of the tank at the location being considered

2.6.4.2 The moment of inertia of the deck transverses, with associated deck plating, is to comply with **Section 10/2.3.2.3** to control the overall deflection of the deck structure.

2.6.4.3 The net section modulus of deck transverses is not to be less than $Z_{in-net50}$ and $Z_{ex-net50}$ as given by the following. The net section modulus of the deck transverses in the wing cargo tanks is also not to be less than required for the deck transverses in the centre tanks.

$$Z_{in-net50} = \frac{1000 M_{in}}{C_{s-pr} \sigma_{yd}} \quad (cm^3)$$

$$Z_{ex-net50} = \frac{1000 M_{ex}}{C_{s-pr} \sigma_{yd}} \quad (cm^3)$$

Where:

M_{in} : design bending moment due to cargo pressure, in kNm , to be taken as:
 (a) for deck transverses in wing cargo tanks of ships with two longitudinal bulkheads, and for deck transverses in cargo tanks of ships with a centreline longitudinal bulkhead:

$$= 0.042 \varphi_t P_{in-dt} S l_{bdg-dt}^2 + M_{st} \quad \text{but is not to be taken as less than } M_0$$

(b) for deck transverses in centre cargo tank of ships with two longitudinal bulkheads:

$$= 0.042 \varphi_t P_{in-dt} S l_{bdg-dt}^2 + M_{vw} \quad \text{but is not to be taken as less than } M_0$$

M_{st} : bending moment transferred from the side transverse

$$= c_{st} \beta_{st} P_{in-st} S l_{bdg-st}^2 \quad (kNm)$$

where a cross tie is fitted in a wing cargo tank and $l_{bdg-st-ct}$ is greater than $0.7l_{bdg-st}$, then l_{bdg-st} in the above formula may be taken as $l_{bdg-st-ct}$.

M_{vw} : bending moment transferred from the vertical web frame on the longitudinal bulkhead

$$= c_{vw} \beta_{vw} P_{in-vw} S l_{bdg-vw}^2 \quad (kNm)$$

where $l_{bdg-vw-ct}$ is greater than $0.7l_{bdg-vw}$, then l_{bdg-vw} in the above formula may be taken as $l_{bdg-vw-ct}$.

for vertically corrugated bulkheads, M_{vw} is to be taken equal to bending moment in upper end of corrugation over the spacing between deck transverses

M_0 : minimum bending moment

$$= 0.083 P_{in-dt} S l_{bdg-dt}^2 \quad (kNm)$$

M_{ex} : design bending moment due to green sea pressure

$$= 0.067 P_{ex-dt} S l_{bdg-dt}^2 \quad (kNm)$$

P_{in-dt} : design cargo pressure for the design load set being considered, calculated at mid point of effective bending span, l_{bdg-dt} , of the deck transverse located at mid tank, in kN/m^2

P_{in-st} : corresponding design cargo pressure in wing cargo tank for the design load set being considered, calculated at the mid point of effective bending span, l_{bdg-st} , of the side transverse located at mid tank, in kN/m^2

P_{in-vw} : corresponding design cargo pressure in the centre cargo tank of ships with two longitudinal bulkheads for the design load set being considered, calculated at mid point of effective bending span, l_{bdg-vw} , of the vertical web frame on the longitudinal bulkhead located at mid tank, in kN/m^2

P_{ex-dt} : design green sea pressure for the design load set being considered, calculated at mid point of effective bending span, l_{bdg-dt} , of the deck transverse located at mid tank, in kN/m^2

- $\varphi_t = 1 - 5 \left(\frac{y_{toe}}{l_{bdg-dt}} \right)$ but is not to be taken as less than 0.6
- y_{toe} : distance from the end of effective bending span, l_{bdg-dt} , to the toe of the end bracket of the deck transverse, in m
- $\beta_{st} = 0.9 \left(\frac{l_{bdg-st}}{l_{bdg-dt}} \right) \left(\frac{I_{dt}}{I_{st}} \right)$ but is not to be taken as less than 0.10 or greater than 0.65
- $\beta_{vw} = 0.9 \left(\frac{l_{bdg-vw}}{l_{bdg-dt}} \right) \left(\frac{I_{dt}}{I_{vw}} \right)$ but is not to be taken as less than 0.10 or greater than 0.50
- S : primary support member spacing, in m , as defined in **Section 4/2.2.2**
- l_{bdg-dt} : effective bending span of the deck transverse, in m , see **Section 4/2.1.4** and **Fig. 8.2.7**, but is not to be taken as less than 60% of the breadth of the tank at the location being considered
- l_{bdg-st} : effective bending span of the side transverse, in m , between the deck transverse and the bilge hopper, see **Section 4/2.1.4** and **Fig. 8.2.7**
- $l_{bdg-st-ct}$: effective bending span of the side transverse, in m , between the deck transverse and the mid depth of the cross tie, where fitted in wing cargo tank, see **Section 4/2.1.4**
- l_{bdg-vw} : effective bending span of the vertical web frame on the longitudinal bulkhead, in m , between the deck transverse and the bottom structure, see **Section 4/2.1.4** and **Fig. 8.2.7**.
- $l_{bdg-vw-ct}$: effective bending span of the vertical web frame on longitudinal bulkhead, in m , between the deck transverse and the mid depth of the cross tie, see **Section 4/2.1.4**
- I_{dt} : net moment of inertia of the deck transverse with an effective breadth of attached plating specified in **Section 4/2.3.2.3**, in cm^4
- I_{st} : net moment of inertia of the side transverse with an effective breadth of attached plating specified in **Section 4/2.3.2.3**, in cm^4
- I_{vw} : net moment of inertia of the longitudinal bulkhead vertical web frame with an effective breadth of attached plating specified in **Section 4/2.3.2.3**, in cm^4
- c_{st} : as defined in **Table 8.2.12**
- c_{vw} : as defined in **Table 8.2.12**
- C_{s-pr} : permissible bending stress coefficient for primary support member as given in **Table 8.2.10**
- σ_{yd} : specified minimum yield stress of the material, in N/mm^2

Table 8.2.12 Values of c_{st} and c_{vw} for Deck Transverses

Structural Configuration			c_{st}	c_{vw}
Ships with centreline longitudinal bulkhead			0.056	-
Ships with two longitudinal bulkheads	Cross tie in centre cargo tank	M_{vw} based on $l_{bdg-vw-ct}$	-	0.044
		M_{st} based on l_{bdg-st} or M_{vw} based on l_{bdg-vw}	0.044	0.016
	Cross ties in wing cargo tanks	M_{st} based on $l_{bdg-st-ct}$ or M_{vw} based on $l_{bdg-vw-ct}$	0.044	0.044
		M_{st} based on l_{bdg-st} or M_{vw} based on l_{bdg-vw}	0.041	0.015

2.6.4.4 The net shear area of deck transverses is not to be less than $A_{shr-in-net50}$ and $A_{shr-ex-net50}$ as given by:

$$A_{shr-in-net50} = \frac{10Q_{in}}{C_{t-pr} \tau_{yd}} \quad (cm^2)$$

$$A_{shr-ex-net50} = \frac{10Q_{ex}}{C_{t-pr} \tau_{yd}} \quad (cm^2)$$

Where:

Q_{in} : design shear force due to cargo pressure
 $= 0.65 P_{in-dt} S l_{shr} + c_1 D b_{ctr} S \rho g$ (kN)

Q_{ex} : design shear force due to green sea pressure
 $= 0.65 P_{ex-dt} S l_{shr}$ (kN)

P_{in-dt} : design cargo pressure for the design load set being considered, calculated at mid point of effective bending span, l_{bdg-dt} , of the deck transverse located at mid tank, in kN/m^2

P_{ex-dt} : design green sea pressure for the design load set being considered, calculated at mid point of effective bending span, l_{bdg-dt} , of the deck transverse located at mid tank, in kN/m^2

S : primary support member spacing, in m , as defined in **Section 4/2.2.2**

l_{shr} : effective shear span, of the deck transverse, in m , see **Section 4/2.1.5**

l_{bdg-dt} : effective bending span of the deck transverse, in m , see **Section 4/2.1.4** and **Fig. 8.2.7**, but is not to be taken as less than 60% of the breadth of the tank at the location being considered

c_1 = 0.04 in way of wing cargo tanks of ships with two longitudinal bulkheads
 = 0.00 in way of centre tank of ships with two longitudinal bulkheads
 = 0.00 for ships with a centreline longitudinal bulkhead

D : moulded depth, in m , as defined in **Section 4/1.1.4**

b_{ctr} : breadth of the centre tank, in m

ρ : density of liquid in the tank, in $tonnes/m^3$, not to be taken less than 1.025, see **Section 2/3.1.8**

g : acceleration due to gravity, $9.81 m/s^2$

C_{t-pr} : permissible shear stress coefficient for primary support member as given in **Table 8.2.10**

$$\tau_{yd} = \frac{\sigma_{yd}}{\sqrt{3}} \quad N/mm^2$$

σ_{yd} : specified minimum yield stress of the material, in N/mm^2

Fig. 8.2.7 Definition of Spans of Deck, Side Transverses, Vertical Web Frames on Longitudinal Bulkheads and Horizontal Stringers on Transverse Bulkheads

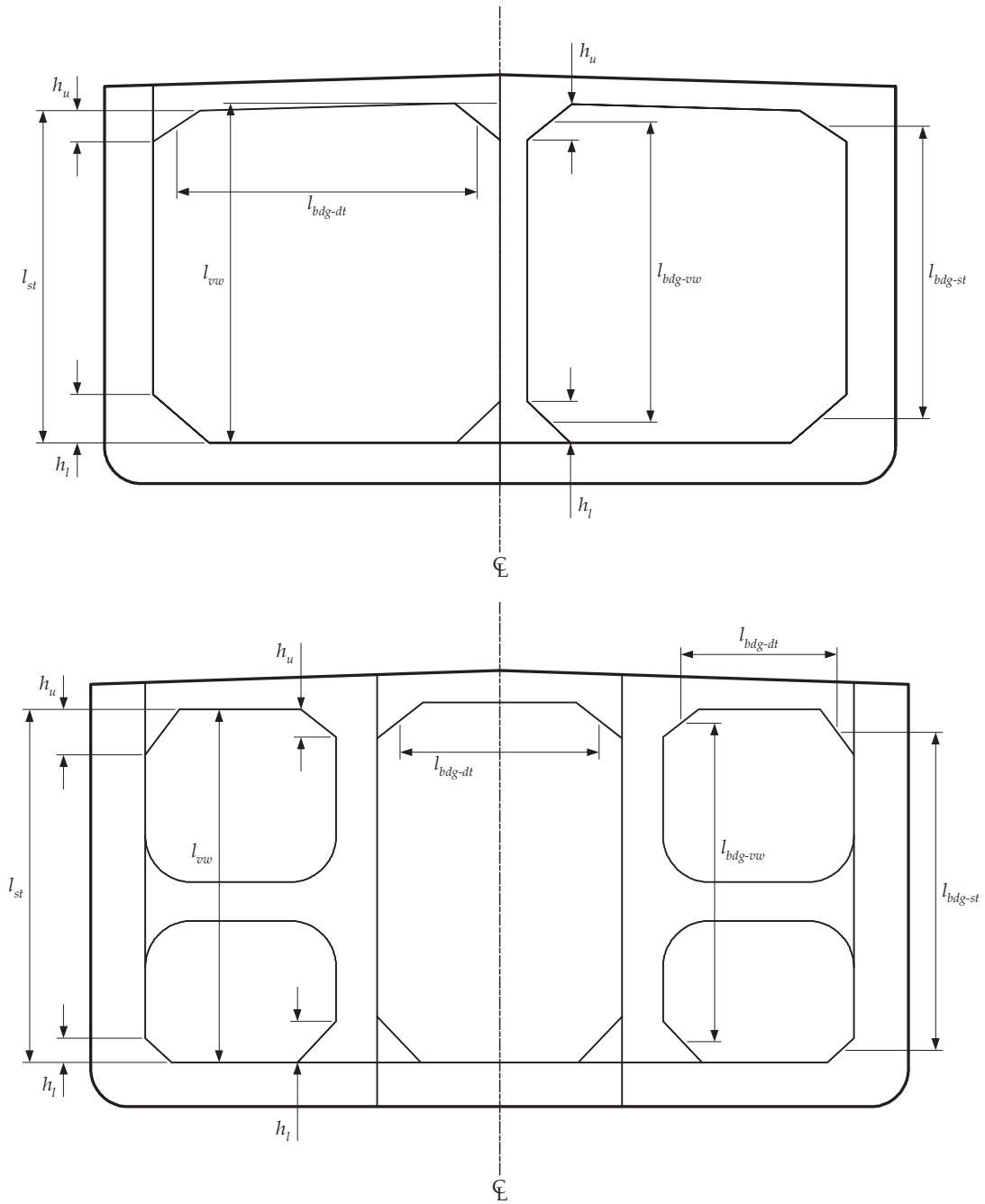
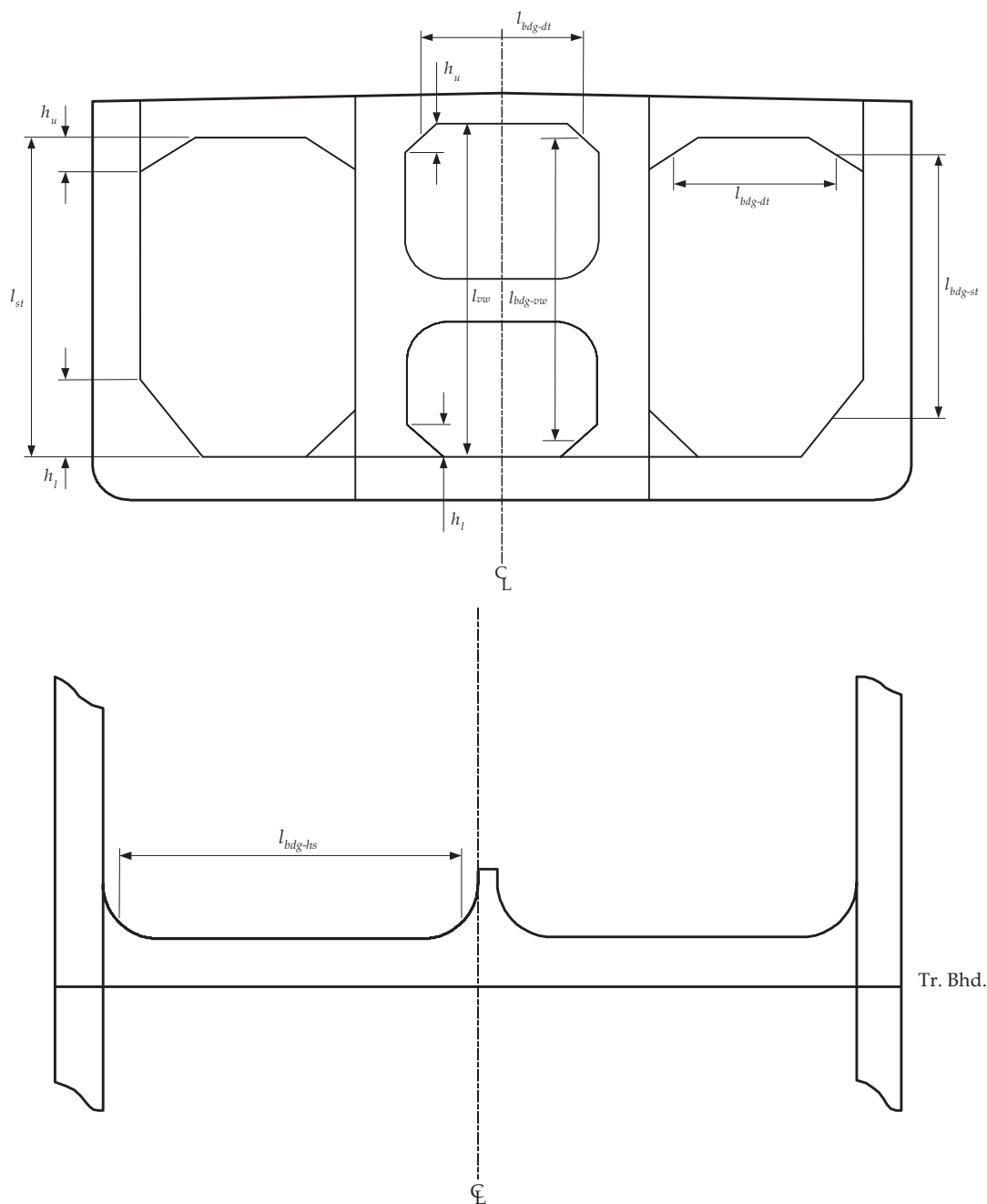

Fig. 8.2.7 (Continued) Definition of Spans of Deck, Side Transverses, Vertical Web Frames on Longitudinal Bulkheads and Horizontal Stringers on Transverse Bulkheads



2.6.5 Side transverses

2.6.5.1 The net shear area, $A_{shr-net50}$, of side transverses is not to be less than:

$$A_{shr-net50} = \frac{10Q}{C_{t-pr} \tau_{yd}} \quad (cm^2)$$

Where:

- Q : design shear force as follows, in kN
- = Q_u for upper part of the side transverse
- = Q_l for lower part of the side transverse

$$Q_u = S [c_u l_{st} (P_u + P_l) - h_u P_u]$$

where a cross tie is fitted in a wing cargo tank and l_{st-ct} is greater than $0.7l_{st}$, then l_{st} in the above formula is to be taken as l_{st-ct} .

- Q_l : to be taken as the greater of the following:
 $S[c_l l_{st} (P_u + P_l) - h_l P_l]$
 $0.35 c_l S l_{st} (P_u + P_l)$
 $1.2 Q_u$
 where a cross tie is fitted in a wing cargo tank and l_{st-ct} is greater than $0.7l_{st}$, then l_{st} in the above formula is to be taken as l_{st-ct} .
- P_u : design pressure for the design load set being considered, in kN/m^2 , calculated at mid tank as follows
 (a) where deck transverses are fitted below deck, P_u is to be calculated at mid height of upper bracket of the side transverse, h_u
 (b) where deck transverses are fitted above deck, P_u is to be calculated at the elevation of the deck at side, except in cases where item (c) applies
 (c) where deck transverses are fitted above deck and the inner hull longitudinal bulkhead is arranged with a top wing structure as follows:
 • the breadth at top of the wing structure is greater than 1.5 times the breadth of the double side and
 • the angle along a line between the point at base of the slope plate at its intersection with the inner hull longitudinal bulkhead and the point at the intersection of top wing structure and deck is 30 degrees or more to vertical
 P_u is to be calculated at mid depth of the top wing structure
- P_l : corresponding design pressure for the design load set being considered, calculated at mid height of bilge hopper, h_l , located at mid tank, in kN/m^2 .
- l_{st} : length of the side transverse, in m , and is to be taken as follows where deck transverses are fitted below deck, l_{st} is the length between the flange of the deck transverse and the inner bottom, see **Fig. 8.2.7** where deck transverses are fitted above deck, l_{st} is the length between the elevation of the deck at side and the inner bottom
- l_{st-ct} : length of the side transverse, in m , and is to be taken as follows:
 (a) where deck transverses are fitted below deck, l_{st} is the length between the flange of the deck transverse and mid depth of cross tie, where fitted in wing cargo tank
 (b) where deck transverses are fitted above deck, l_{st} is the length between the elevation of the deck at side and mid depth of the cross tie, where fitted in wing cargo tank
- S : primary support member spacing, in m , as defined in **Section 4/2.2.2**
- h_u : effective length of upper bracket of the side transverse, in m , and is to be taken as follows
 (a) where deck transverses are fitted below deck, h_u is as shown in **Fig. 8.2.7** and as described in **Section 4/2.1.5**.
 (b) where deck transverses are fitted above deck, h_u is to be taken as 0.0, except in cases where item (c) applies.
 (c) where deck transverses are fitted above deck and the inner hull longitudinal bulkhead is arranged with a top wing structure as follows:
 • the breadth at top of the wing structure is greater than 1.5 times the breadth of the double side, and
 • the angle along a line between the point at base of the slope plate at its intersection with the inner hull longitudinal bulkhead and the point at the intersection of top wing structure and the deck is 30 degrees or more to vertical
 h_u is to be taken as the distance between the deck at side and the lower end of slope plate of the top wing structure.

- h_l : height of bilge hopper, in m , as shown in **Fig. 8.2.7**
 c_u and c_l : as defined in **Table 8.2.13**
 C_{t-pr} : permissible shear stress coefficient for primary support member as given in **Table 8.2.10**
 $\tau_{yd} = \frac{\sigma_{yd}}{\sqrt{3}}$ (N/mm^2)
 σ_{yd} : specified minimum yield stress of the material, in N/mm^2

 Table 8.2.13 Values of c_u and c_l for Side Transverses

Structural Configuration			c_u		c_l	
Number of the side stringers			Less than three	Equal to or greater than three	Less than three	Equal to or greater than three
Ships with a centreline longitudinal bulkhead						
Ships with two longitudinal bulkheads	Cross tie in centre cargo tank		0.12	0.09	0.29	0.21
	Cross ties in wing cargo tanks	Q_u or Q_l based on l_{st-cl}				
		Q_u or Q_l based on l_{st}	0.08		0.20	

2.6.5.2 The shear area over the length of the side transverse is to comply with the following:

- the required shear area for the upper part is to be maintained over the upper $0.2 l_{shr}$
- the required shear area for the lower part is to be maintained over the lower $0.2 l_{shr}$
- where Q_u and Q_l are determined based on l_{st-cl} , the required shear area for the lower part is also to be maintained below the cross tie
- for ships without cross ties in the wing cargo tanks, the required shear area between the upper and lower parts is to be reduced linearly towards 50% of the required shear area for the lower part at mid span
- for ships with cross ties in the wing cargo tanks, the required shear area along the span is to be tapered linearly between the upper and lower parts

Note

When materials of different yield stress are employed, appropriate adjustments are to be made to account for differences in material yield stress

Where:

- l_{shr} : effective shear span of the side transverse, in m
 $= l_{st} - h_u - h_l$ where Q_u and Q_l are determined based on l_{st}
 $= l_{st-cl} - h_u$ where Q_u and Q_l are determined based on l_{st-cl}
 l_{st} , l_{st-cl} , h_u , h_l , Q_u and Q_l : as defined in **2.6.5.1**

2.6.6 Vertical web frames on longitudinal bulkhead

2.6.6.1 The web depth of the vertical web frame on the longitudinal bulkhead is not to be less than:

- $0.14 l_{bdg-vw}$ for ships with a centreline longitudinal bulkhead
- $0.09 l_{bdg-vw}$ for ships with two longitudinal bulkheads
- see also **2.6.1.7**

Where:

- l_{bdg-vw} : effective bending span of the vertical web frame on the longitudinal bulkhead, see **2.6.6.2** and **Fig. 8.2.7**

2.6.6.2 The net section modulus, Z_{net50} , of the vertical web frame is not to be less than:

$$Z_{net50} = \frac{1000M}{C_{s-pr} \sigma_{yd}} \quad (cm^3)$$

Where:

- M : design bending moment, in kNm , as follows
 $= c_u P S l_{bdg-vw}^2$ for upper part of the web frame
 $= c_l P S l_{bdg-vw}^2$ for lower part of the web frame
 where a cross tie is fitted and $l_{bdg-vw-ct}$ is greater than $0.7l_{bdg-vw}$, then l_{bdg-vw} in the above formula is to be taken as $l_{bdg-vw-ct}$.
- P : design pressure for the design load set being considered, calculated at mid point of the effective bending span, l_{bdg-vw} , of the vertical web frame located at mid tank, in kN/m^2
- l_{bdg-vw} : effective bending span of the vertical web frame on the longitudinal bulkhead, between the deck transverse and the bottom structure, in m , see **Section 4/2.1.4** and **Fig. 8.2.7**.
- $l_{bdg-vw-ct}$: effective bending span of the vertical web frame on longitudinal bulkhead, between the deck transverse and mid depth of the cross tie on ships with two longitudinal bulkheads, in m , see **Section 4/2.1.4**
- S : primary support member spacing, in m , as defined in **Section 4/2.2.2**
- C_{s-pr} : permissible bending stress coefficient as given in **Table 8.2.10**
- σ_{yd} : specified minimum yield stress of the material, in N/mm^2
- c_u and c_l : as defined in **Table 8.2.14**

Table 8.2.14 Values of c_u and c_l for Vertical Web Frame on Longitudinal Bulkheads

Structural Configuration		c_u	c_l
Ships with a centreline longitudinal bulkhead		0.057	0.071
Ships with two longitudinal bulkheads	Cross tie in centre cargo tank	M based on $l_{bdg-vw-ct}$	0.057
		M based on l_{bdg-vw}	0.012
	Cross ties in wing cargo tanks	M based on $l_{bdg-vw-ct}$	0.057
		M based on l_{bdg-vw}	0.016

2.6.6.3 The section modulus over the length of the vertical web frame on the longitudinal bulkhead is to comply with the following:

- the required section modulus for the upper part is to be maintained over the upper $0.2 l_{bdg-vw}$ or $0.2 l_{bdg-vw-ct}$, as applicable
- the required section modulus for the lower part is to be maintained over the lower $0.2 l_{bdg-vw}$ or $0.2 l_{bdg-vw-ct}$, as applicable
- where the required section modulus is determined based on $l_{bdg-vw-ct}$, the required section modulus for the lower part is also to be maintained below the cross tie
- the required section modulus between the upper and lower parts is to be reduced linearly to 70% of the required section modulus for the lower part at mid span

Note

When materials of different yield stress are employed, appropriate adjustments are to be made to account for differences in material yield stress.

Where:

l_{bdg-vw} and $l_{bdg-vw-ct}$ as defined in **2.6.6.2**

2.6.6.4 The net shear area, $A_{shr-net50}$, of the vertical web frame is not to be less than:

$$A_{shr-net50} = \frac{10Q}{C_{t-pr} \tau_{yd}} \quad (cm^2)$$

Where:

Q : design shear force as follows, in kN
 = Q_u for upper part of the web frame
 = Q_l for lower part of the web frame

$$Q_u = S [c_u l_{vw} (P_u + P_l) - h_u P_u]$$

where a cross tie is fitted in a centre or wing cargo tank and l_{vw-ct} is greater than $0.7l_{vw}$, then l_{vw} in the above formula is to be taken as l_{vw-ct} .

Q_l to be taken as the greater of the following

(a) $S[c_l l_{vw} (P_u + P_l) - h_l P_l]$

(b) $c_w S c_l l_{vw} (P_u + P_l)$

(c) $1.2Q_u$

where a cross tie is fitted in a centre or wing cargo tank and l_{vw-ct} is greater than $0.7l_{vw}$, then l_{vw} in the above formula is to be taken as l_{vw-ct} .

P_u : design pressure for the design load set being considered, calculated at mid height of upper bracket of the vertical web frame, h_u , located at mid tank, in kN/m^2

P_l : design pressure for the design load set being considered, calculated at mid height of lower bracket of the vertical web frame, h_l , located at mid tank, in kN/m^2

l_{vw} : length of the vertical web frame, in m , between the flange of the deck transverse and the inner bottom, see **Fig. 8.2.7**

l_{vw-ct} : length of the vertical web frame, in m , between the flange of the deck transverse and mid depth of the cross tie, where fitted

S : primary support member spacing, in m , as defined in **Section 4/2.2.2**

h_u : effective length of upper bracket of the vertical web frame, in m , as shown in **Fig. 8.2.7** and as described in **Section 4/2.1.5**

h_l : effective length of lower bracket of the vertical web frame, in m , as shown in **Fig. 8.2.7** and as described in **Section 4/2.1.5**

c_u and c_l : as defined in **Table 8.2.15**

c_w 0.57 for ships with a centreline longitudinal bulkhead
 0.50 for ships with two longitudinal bulkheads

C_{t-pr} : permissible shear stress coefficient for primary support member as given in **Table 8.2.10**

$$\tau_{yd} = \frac{\sigma_{yd}}{\sqrt{3}} \quad (N/mm^2)$$

σ_{yd} : specified minimum yield stress of the material, in N/mm^2

Table 8.2.15 Values of c_u and c_l for Vertical Web Frame on Longitudinal Bulkhead

Structural Configuration	c_u	c_l
Ships with a centreline longitudinal bulkhead	0.17	0.28
Ships with two longitudinal bulkheads		
	Q_u or Q_l based on l_{vw-ct}	
	Q_u or Q_l based on l_{vw}	0.18

2.6.6.5 The shear area over the length of the vertical web frame on the longitudinal bulkhead is to comply with the following:

- (a) the required shear area for the upper part is to be maintained over the upper $0.2 l_{shr}$
- (b) the required shear area for the lower part is to be maintained over the lower $0.2 l_{shr}$
- (c) where Q_u and Q_l are determined based on l_{vw-ct} , the required shear area for the lower part is also to be maintained below the cross tie
- (d) for ships without cross ties in the wing or centre cargo tanks, the required shear area between the upper and lower parts is to be reduced linearly towards 50% of the required shear area for the lower part at mid span
- (e) for ships with cross ties in the wing or centre cargo tanks, the required shear area along the span is to be tapered linearly between the upper and lower parts

Note

When materials of different yield stress are employed, appropriate adjustments are to be made to account for differences in material yield stress.

Where:

l_{shr} : effective shear span of the side transverse
 $= l_{vw} - h_u - h_l$ where Q_u and Q_l are determined based on l_{vw}
 $= l_{vw-ct} - h_u$ where Q_u and Q_l are determined based on l_{vw-ct}

l_{vw} , l_{vw-ct} , h_u , h_l , Q_u and Q_l : as defined in **2.6.6.4**

2.6.7 Horizontal stringers on transverse bulkheads

2.6.7.1 The web depth of horizontal stringers on transverse bulkhead is not to be less than:

- (a) $0.28 l_{bdg-hs}$ for horizontal stringers in wing cargo tanks of ships with two longitudinal bulkheads
- (b) $0.20 l_{bdg-hs}$ for horizontal stringers in centre tanks of ships with two longitudinal bulkheads, but the web depth of horizontal stringers in centre tank is not to be less than required depth for a horizontal stringer in wing cargo tanks
- (c) $0.20 l_{bdg-hs}$ for horizontal stringers of ships with a centreline longitudinal bulkhead
- (d) see also **2.6.1.7**.

Where:

l_{bdg-hs} : effective bending span of the horizontal stringer, in m , but is not to be taken as less than 50% of the breadth of the tank at the location being considered, see **Section 4/2.1.4** and **Fig. 8.2.7**

2.6.7.2 The net section modulus, Z_{net50} , of the horizontal stringer over the end $0.2 l_{bdg-hs}$ is not to be less than:

$$Z_{net50} = \frac{1000 M}{C_{s-pr} \sigma_{yd}} \quad (cm^3)$$

Where:

M : design bending moment
 $= c P S l_{bdg-hs}^2 \quad (kNm)$

P : design pressure for the design load set being considered, calculated at mid point of effective bending span, l_{bdg-hs} , and at mid point of the spacing, S , of the horizontal stringer, in kN/m^2

S : sum of the half spacing (distance between stringers) on each side of the horizontal stringer under consideration, in m

l_{bdg-hs} : effective bending span of the horizontal stringer, in m , but is not to be taken as less than 50% of the breadth of the tank at the location being considered, see **Section 4/2.1.4** and **Fig. 8.2.7**

c 0.073 for horizontal stringers in cargo tanks of ships with a centreline bulkhead
 0.083 for horizontal stringers in wing cargo tanks of ships with two longitudinal bulkheads
 0.063 for horizontal stringers in the centre tank of ships with

two longitudinal bulkheads

C_{s-pr} : permissible bending stress coefficient as given in **Table 8.2.10**

σ_{yd} : specified minimum yield stress of the material, in N/mm^2

2.6.7.3 The required section modulus at mid effective bending span is to be taken as 70% of that required at the ends, intermediate values are to be obtained by linear interpolation. When materials of different yield stress are employed, appropriate adjustments are to be made to account for differences in material yield stress.

2.6.7.4 The net shear area, $A_{shr-net50}$, of the horizontal stringer over the end $0.2 l_{shr}$ is not to be less than:

$$A_{shr-net50} = \frac{10Q}{C_{t-pr} \tau_{yd}} \quad (cm^2)$$

Where:

Q : design shear force
 $= 0.5 P S l_{shr}$ (kN)

P : design pressure for the design load set being considered, calculated at mid point of effective bending span, l_{bdg-hs} , and at mid point of the spacing, S , of the horizontal stringer, in kN/m^2

S : sum of the half spacing (distance between stringers), on each side of the horizontal stringer under consideration, in m

l_{shr} : effective shear span of the horizontal stringer, in m , see **Section 4/2.1.5**

C_{t-pr} : permissible shear stress coefficient as given in **Table 8.2.10**

$\tau_{yd} = \frac{\sigma_{yd}}{\sqrt{3}}$ (N/mm^2)

σ_{yd} : specified minimum yield stress of the material, in N/mm^2

2.6.7.5 The required shear area at mid effective shear span is to be taken as 50% of that required in the ends, intermediate values are to be obtained by linear interpolation. When materials of different yield stress are employed, appropriate adjustments are to be made to account for differences in material yield stress.

2.6.8 Cross ties

2.6.8.1 The maximum applied design axial load on cross ties, W_{ct} , is to be less than or equal to the permissible load, $W_{ct-perm}$, as given by:

$$W_{ct} \leq W_{ct-perm}$$

Where:

W_{ct} : applied axial load
 $= P b_{ct} S$ (kN)

$W_{ct-perm}$: permissible load
 $= 0.1 A_{ct-net50} \eta_{ct} \sigma_{cr}$ (kN)

P : maximum design pressure for all the applicable design load sets being considered, calculated at centre of the area supported by the cross tie located at mid tank, in kN/m^2

b_{ct} : where cross tie is fitted in centre cargo tank:

$$= 0.5 l_{bdg-vw}$$

: where cross ties are fitted in wing cargo tanks:

$$= 0.5 l_{bdg-vw} \quad \text{for design cargo pressure from the centre cargo tank}$$

$$= 0.5 l_{bdg-st} \quad \text{for design sea pressure}$$

l_{bdg-vw} : effective bending span of the vertical web frame on the longitudinal bulkhead, in m , see **Section 4/2.1.4** and **Fig. 8.2.7**.

l_{bdg-st} : effective bending span of the side transverse, in m , see **Section 4/2.1** and **Fig. 8.2.7**.

S : primary support member spacing, in m , as defined in **Section 4/2.2.2**

η_{ct} : utilisation factor, to be taken as:
 $= 0.65$ for acceptance criteria set AC1

= 0.75 for acceptance criteria set AC2

σ_{cr} : critical buckling stress in compression of the cross tie, in N/mm^2 , as calculated using the net sectional properties in accordance with **Section 10/3.5.1**, where the effective length of the cross tie is to be taken as follows, in m

- (a) for cross tie in centre tank:
distance between the flanges of longitudinal stiffeners on the starboard and port longitudinal bulkheads to which the cross tie's horizontal stiffeners are attached
- (b) for cross tie in wing tank:
distance between the flanges of longitudinal stiffeners on the longitudinal bulkhead to which the cross tie's horizontal stiffeners are attached, and the inner hull plating

$A_{ct-net50}$: net cross sectional area of the cross tie, in cm^2

2.6.8.2 Special attention is to be paid to the adequacy of the welded connections for the transmission of the forces, and also to the stiffening arrangements, in order to provide effective means for transmission of the compressive forces into the webs. Particular attention is to be paid to the welding at the toes of all end brackets of the cross ties.

2.6.8.3 Horizontal stiffeners are to be located in line with, and attached to, the longitudinals at the ends of the cross ties.

2.6.9 Primary support members located beyond $0.4L_{CSR-T}$ amidships

2.6.9.1 If a cargo tank FE analysis is not available for the region outside of $0.4L_{CSR-T}$ amidships, the requirements given in **2.6.9.2** and **2.6.9.3** may be used to obtain the scantlings of primary support members located beyond $0.4L_{CSR-T}$ of amidships. Scantlings used for the $0.4L_{CSR-T}$ amidships are to be those required by **Sections 8/2** and **Section 9/2**, see **2.6.1.3** and **2.6.1.4**.

2.6.9.2 The net section modulus of primary support members, $Z_{end-net50}$, located beyond $0.4L_{CSR-T}$ of amidships is not to be less than:

$$Z_{end-net50} = \frac{Z_{mid-net50} \sigma_{yd-mid} M_{end}}{\sigma_{yd-end} M_{mid}} \quad (cm^3)$$

Where:

- M_{end} : bending moment, in kNm , for the structural member under consideration located beyond $0.4L_{CSR-T}$ amidships, calculated in accordance with corresponding requirements of **2.6.3** to **2.6.8** and using the design pressure specified for the given location
- M_{mid} : bending moment, in kNm , for the corresponding structural member and location of cross section, amidships, obtained from the corresponding requirements of **2.6.2** to **2.6.8**
- $Z_{mid-net50}$: net section modulus at the flange of the corresponding structural member and location of cross section amidships, in cm^3
- σ_{yd-end} : specified minimum yield stress of the flange of the structural member under consideration located beyond $0.4L_{CSR-T}$ amidships, in N/mm^2
- σ_{yd-mid} : specified minimum yield stress of the flange of the structural member under consideration amidships, in N/mm^2

2.6.9.3 The net shear area for primary support members, $A_{shr-end-net50}$, located beyond $0.4L_{CSR-T}$ amidships is not to be less than:

$$A_{shr-end-net50} = \frac{A_{shr-mid-net50} \tau_{yd-mid} Q_{end}}{\tau_{yd-end} Q_{mid}} \quad (cm^2)$$

Where:

- Q_{end} : shear force, in kN , for the structural member under consideration located beyond $0.4L_{CSR-T}$ of amidships, calculated in accordance with the corresponding requirements of **2.6.3** to **2.6.8** and using the design pressure, specified for the given location

- Q_{mid} : shear force, in kN , for the corresponding structural member and corresponding location of cross section, amidships, obtained from the requirements of **2.6.2** to **2.6.8**
- $A_{shr-mid-net50}$: shear area of corresponding structural member and location of cross section amidships, in cm^2
- $\tau_{yd-end} = \frac{\sigma_{yd-end}}{\sqrt{3}}$
- $\tau_{yd-mid} = \frac{\sigma_{yd-mid}}{\sqrt{3}}$
- σ_{yd-end} : specified minimum yield stress of the structural member under consideration located beyond $0.4L_{CSR-T}$ amidships, in N/mm^2
- σ_{yd-mid} : specified minimum yield stress of the structural member under consideration amidships, in N/mm^2

3. Forward of the Forward Cargo Tank

3.1 General

3.1.1 Application

3.1.1.1 The requirements of this Sub-Section apply to structure forward of the forward end of the foremost cargo tank. Where the forward end of the foremost cargo tank is aft of $0.1L_{CSR-T}$ of the ship's length, measured from the F.P., special consideration will be given to the applicability of these requirements and the requirements of **Section 8/2**.

3.1.1.2 The net scantlings described in this Sub-Section are related to gross scantlings as follows:

- (a) for application of the minimum thickness requirements of **3.1.4**, the gross thickness is obtained from the applicable requirements by adding the full corrosion additions specified in **Section 6/3**.
- (b) for plating and local support members, the gross thickness and gross cross sectional properties are obtained from the applicable requirements by adding the full corrosion additions specified in **Section 6/3**
- (c) for primary support members, the gross shear area, gross section modulus and other gross cross sectional properties are obtained from the applicable requirements by adding one half of the relevant full corrosion additions specified in **Section 6/3**
- (d) for application of buckling requirements of **Section 10/2** the gross thickness and gross cross sectional properties are obtained from the applicable requirements by adding the full corrosion additions specified in **Section 6/3**.

3.1.2 General scantling requirements

3.1.2.1 The hull structure is to comply with the applicable requirements of:

- (a) hull girder longitudinal strength, see **Section 8/1**
- (b) strength against sloshing and impact loads, see **Section 8/6**
- (c) buckling/ultimate strength, see **Section 10**.

3.1.2.2 The deck plating thickness and supporting structure are to be suitably reinforced in way of the anchor windlass and other deck machinery, and in way of cranes, masts and derrick posts. See **Section 11/3**.

3.1.2.3 The net section modulus, shear area and other sectional properties of local and primary support members are to be determined in accordance with **Section 4/2**.

3.1.2.4 The section modulus and web thickness of the local support members apply to the areas clear of the end brackets. The section modulus and cross sectional shear areas of the primary support members are to be applied as required in the notes to **Table 8.3.5**.

3.1.2.5 The scantling criteria are based on assumptions that all structural joints and welded details are designed and fabricated such that they are compatible with the anticipated working stress levels at the locations considered. The loading patterns, stress concentrations and potential failure modes of structural joints and details during the design of highly stressed regions are to be considered. Structural design details are to comply with the requirements in **Section 4/3**.

3.1.2.6 Limber, drain and air holes are to be cut in all parts of the structure, as required, to ensure free flow to the suction pipes and the escape of air to the vents. Arrangements are to be made for draining the spaces above deep tanks. See also **Section 4/3**.

3.1.2.7 Web stiffeners are to be fitted on primary support members at each longitudinal on the side and bottom shell. Alternative arrangements may be accepted where adequacy of stiffener end connections and strength of adjoining web and bulkhead plating is demonstrated.

3.1.3 Structural continuity

3.1.3.1 Scantlings of the shell envelope, upper deck and inner bottom are to be tapered towards the forward end. See also **1.6**.

3.1.3.2 In the transition zone aft of the fore peak into the forward cargo tank, due consideration is to be given to the arrangement of major longitudinal members in order to avoid abrupt changes in section. Structures within the fore peak, such as flats, decks, horizontal ring frames or side stringers, are to be scarphed effectively into the structure aft

into the cargo tank. Where such structures are in line with longitudinal members aft of the forward cargo tank bulkhead fitting of tapered transition brackets may be used.

3.1.3.3 Where inner hull or longitudinal bulkhead structures terminate at the forward bulkhead of the forward cargo tank, adequate backing structure is to be provided together with tapering brackets to ensure continuity of strength.

3.1.3.4 Longitudinal framing of the strength deck is to be carried as far forward as practicable.

3.1.3.5 All shell frames and tank boundary stiffeners are to be continuous, or are to be bracketed at their ends, except as permitted in **Sections 4/3.2.4** and **4/3.2.5**.

3.1.4 Minimum thickness

3.1.4.1 In addition to the thickness, section modulus and stiffener web shear area requirements as given in this Sub-Section, the thickness of plating and stiffeners in the forward region are to comply with the appropriate minimum thickness requirements given in **Table 8.3.1**.

Table 8.3.1 Minimum Net Thickness of Structure Forward of the Forward Cargo Tank

Scantling Location			Net Thickness (<i>mm</i>)
Plating	Shell	Keel plating	See 2.1.5.1
		Bottom shell/bilge/side shell plating	See 2.1.5.1
	Upper Deck		See 2.1.5.1
	Other structure	Hull internal tank boundaries	See 2.1.5.1
		Non-tight bulkheads, bulkheads between dry spaces and other plates in general	See 2.1.5.1
		Pillar bulkheads	7.5
		Breasthooks	6.5
	Floors and bottom girders		
Web plating of primary support members			$6.5 + 0.015L_2$
Local support members			See 2.1.5.1
Tripping brackets			See 2.1.5.1

Where:

L_2 : rule length, L_{CSR-T} , in *m*, as defined in **Section 4/1.1.1.1**, but need not be taken greater than 300*m*

3.2 Bottom Structure

3.2.1 Plate keel

3.2.1.1 A flat plate keel is to extend as far forward as practical and is to satisfy the scantling requirements given in **2.2.1**.

3.2.2 Bottom shell plating

3.2.2.1 The thickness of the bottom shell plating is to comply with the requirements in **3.9.2.1**.

3.2.3 Bottom longitudinals

3.2.3.1 Bottom longitudinals are to be carried as far forward as practicable. Beyond this, suitably stiffened frames are to be fitted.

3.2.3.2 The section modulus and thickness of the bottom longitudinals are to comply with the requirements in **3.9.2.2** and **3.9.2.3**.

3.2.4 Bottom floors

3.2.4.1 Bottom floors are to be fitted at each web frame location. The minimum depth of the floor at the centreline is to be not be less than the required depth of the double bottom of the cargo tank region. See **Section 5/3.2.1.1**.

3.2.5 Bottom girders

3.2.5.1 A supporting structure is to be provided at the centreline either by extending the centreline girder to the stem or by providing a deep girder or centreline bulkhead.

3.2.5.2 Where a centreline girder is fitted, the minimum depth and thickness is not to be less than that required for the depth of the double bottom in the cargo tank region, and the upper edge is to be stiffened. Where a centreline wash bulkhead is fitted, the lowest strake is to have thickness not less than required for a centreline girder.

3.2.5.3 Where a longitudinal wash bulkhead supports bottom transverses, the details and arrangements of openings in the bulkhead are to be configured to avoid areas of high stresses in way of the connection of the wash bulkhead with bottom transverses.

3.2.6 Plate stems

3.2.6.1 Plate stems are to be supported by stringers and flats, and by intermediate breasthook diaphragms spaced not more than 1500mm apart, measured along the stem. Where the stem radius is large, a centreline support structure is to be fitted.

3.2.6.2 Between the minimum design ballast draught, T_{bal} , at the stem and the scantling draught, T_{sc} , the plate stem net thickness, $t_{stem-net}$, is not to be less than:

$$t_{stem-net} = \frac{L_2 \sqrt{\frac{235}{\sigma_{yd}}}}{12} \quad (mm), \text{ but need not be taken as greater than } 21mm$$

Where:

L_2 : rule length, L_{CSR-T} , in m , as defined in **Section 4/1.1.1.1**, but need not be taken greater than 300m

σ_{yd} : specified minimum yield stress of the material, in N/mm^2

Above the scantling draught the thickness of the stem plate may be tapered to the requirements for the shell plating at the upper deck.

Below the minimum design ballast draught the thickness of the stem plate may be tapered to the requirements for the plate keel.

3.2.7 Floors and girders in spaces aft of the collision bulkhead

3.2.7.1 Floors and girders which are aft of the collision bulkhead and forward of the forward cargo tank, are to comply with the requirements in **3.2.4** and **3.2.5** and are to comply with the shear area requirements in **3.9.3.3**.

3.3 Side Structure

3.3.1 Side shell plating

3.3.1.1 The thickness of the side shell plating is to comply with the requirements in **3.9.2.1**. Where applicable, the thickness of the side shell plating is to comply with the requirements in **2.2.4.2**.

3.3.1.2 Where a forecastle is fitted, the side shell plating requirements are to be applied to the plating extending to the forecastle deck elevation.

3.3.2 Side shell local support members

3.3.2.1 Longitudinal framing of the side shell is to be carried as far forward as practicable.

3.3.2.2 The section modulus and thickness of the hull envelope framing is to comply with the requirements in **3.9.2.2** and **3.9.2.3**.

3.3.2.3 End connections of longitudinals at transverse bulkheads are to provide adequate fixity, lateral support, and where not continuous are to be provided with soft-nosed brackets. Brackets lapped onto the longitudinals are not to be used.

3.3.3 Side shell primary support structure

3.3.3.1 In general, the spacing of web frames, S as defined in **Section 4/2.2.2**, is to be taken as:

$$S = 2.6 + 0.005L_2 \quad (m), \text{ but not to be taken greater than } 3.5m$$

Where:

L_2 : rule length, L_{CSR-T} , as defined in **Section 4/1.1.1.1**, but is not to be taken greater than $300m$

3.3.3.2 In general, the transverse framing forward of the collision bulkhead stringers are to be spaced approximately $3.5m$ apart. Stringers are to have an effective span not greater than $10m$, and are to be adequately supported by web frame structures. Aft of the collision bulkhead, where transverse framing is adopted, the spacing of stringers may be increased.

3.3.3.3 Perforated flats are to be fitted to limit the effective span of web frames to not greater than $10m$.

3.3.3.4 The scantlings of web frames supporting longitudinal frames, and stringers and/or web frames supporting transverse frames in the forward region are to be determined from **3.9.3**, with the following additional requirements:

- (a) where no cross ties are fitted:
 - the required section modulus of the web frame is to be maintained for 60% of the effective span for bending, measured from the lower end. The value of the bending moment used for calculation of the required section modulus of the remainder of the web frame may be appropriately reduced, but not greater than 20%
 - the required shear area of the lower part of the web frame is to be maintained for 60% of the shear span measured from the lower end.
- (b) where one cross tie is fitted:
 - the effective spans for bending and shear of a web frame or stringer are to be taken ignoring the presence of the cross tie. The shear forces and bending moments may be reduced to 50% of the values that are calculated ignoring the presence of the cross ties. For a web frame, the required section modulus and shear area of the lower part of the web frame is to be maintained up to the cross tie, and the required section modulus and shear area of the upper part of the web frame is to be maintained for the section above the cross tie
 - cross ties are to satisfy the requirements of **2.6.8** using the design loads specified in **Table 8.3.8**.
- (c) configurations with multiple cross ties are to be specially considered, in accordance with **3.3.3.4(d)**
- (d) where complex grillage structures are employed the suitability of the scantlings of the primary support members is to be determined by more advanced calculation methods.

3.3.3.5 The web depth of primary support members is not to be less than 14% of the bending span and is to be at least 2.5 *times* as deep as the slots for stiffeners if the slots are not closed.

3.4 Deck Structure

3.4.1 Deck plating

3.4.1.1 The thickness of the deck plating is to comply with the requirements in **3.9.2.1** with the applicable lateral pressure, green sea and deck loads.

3.4.1.2 (void)

3.4.2 Deck stiffeners

3.4.2.1 The section modulus and thickness of deck stiffeners are to comply with the requirements in **3.9.2.2** and **3.9.2.3**, with the applicable lateral pressure, green sea and deck loads.

3.4.3 Deck primary support structure

3.4.3.1 The section modulus and shear area of primary support members are to comply with the requirements in **3.9.3**.

3.4.3.2 The web depth of primary support members is not to be less than 10% and 7% of the unsupported span in bending in tanks and in dry spaces, respectively, and is not to be less than 2.5 times the depth of the slots if the slots are not closed. Unsupported span in bending is bending span as defined in **Section 4/2.1.4** or in case of a grillage structure, the distance between connections to other primary support members.

3.4.3.3 In way of concentrated loads from heavy equipment, the scantlings of the deck structure are to be determined based on the actual loading. See also **Section 11/3**.

3.4.4 Pillars

3.4.4.1 Pillars are to be fitted in the same vertical line wherever possible and effective arrangements are to be made to distribute the load at the heads and heels of all pillars. Where pillars support eccentric loads, they are to be strengthened for the additional bending moment imposed upon them.

3.4.4.2 Tubular and hollow square pillars are to be attached at their heads and heels by efficient brackets or doublers/insert plates, where applicable, to transmit the load effectively. Pillars are to be attached at their heads and heels by continuous welding. At the heads and heels of pillars built of rolled sections, the load is to be distributed by brackets or other equivalent means.

3.4.4.3 Pillars in tanks are to be of solid section. Where the hydrostatic pressure may result in tensile stresses in the pillar, the tensile stress in the pillar and its end connections is not to exceed 45% of the specified minimum yield stress of the material.

3.4.4.4 The scantlings of pillars are to comply with the requirements in **3.9.5**.

3.4.4.5 Where the loads from heavy equipment exceed the design load of **3.9.5**, the pillar scantlings are to be determined based on the actual loading.

3.5 Tank Bulkheads

3.5.1 General

3.5.1.1 Tanks may be required to have divisions or deep wash plates in order to minimise the dynamic stress on the structure.

3.5.2 Construction

3.5.2.1 In no case are the scantlings of tank boundary bulkheads to be less than the requirements for watertight bulkheads.

3.5.3 Scantlings of tank boundary bulkheads

3.5.3.1 The thickness of tank boundary plating is to comply with the requirements in **3.9.2.1**.

3.5.3.2 The section modulus and thickness of stiffeners are to comply with the requirements in **3.9.2.2** and **3.9.2.3**.

3.5.3.3 The section modulus and shear area of primary support members are to comply with the requirements in **3.9.3**.

3.5.3.4 Web plating of primary support members is to have a depth of not less than 14% of the unsupported span in bending, and is not to be less than 2.5 times the depth of the slots if the slots are not closed.

3.5.3.5 Scantlings of corrugated bulkheads are to comply with the requirements in **3.9.4**.

3.6 Watertight Boundaries

3.6.1 General

3.6.1.1 Watertight boundaries are to be fitted in accordance with **Section 5/2**.

3.6.2 Collision bulkhead

3.6.2.1 The scantlings of structural components of the collision bulkheads are to comply with the requirements in **3.6.3**, as applicable. Additionally, the collision bulkhead is to comply with the requirements in **3.6.2.2** to **3.6.2.4**.

3.6.2.2 The position of the collision bulkhead is to be in accordance with **Section 5/2.2**.

3.6.2.3 Doors, manholes, permanent access openings or ventilation ducts are not to be cut in the collision bulkhead below the freeboard deck. Where the collision bulkhead is extended above the freeboard deck, the number of openings in the extension is to be kept to a minimum compatible with the design and proper working of the ship. The openings are to be fitted with weathertight closing appliances. The collision bulkhead may be pierced by pipes necessary for dealing with the contents of tanks forward of the bulkhead, provided the pipes are fitted with valves capable of being operated from above the freeboard deck. The valves are generally to be fitted on the collision bulkhead inside the fore peak and are not to be fitted inside the cargo tank.

3.6.2.4 Compartments forward of the collision bulkhead may not be arranged for the carriage of flammable liquids.

3.6.3 Scantlings of watertight boundaries

3.6.3.1 The thickness of boundary plating is to comply with the requirements in **3.9.2.1**.

3.6.3.2 The section modulus and thickness of stiffeners are to comply with the requirements in 3.9.2.2 and 3.9.2.3.

3.6.3.3 The section modulus and shear area of primary support members are to comply with the requirements in 3.9.3.

3.6.3.4 Web plating of primary support members is to have a depth of not less than 10% of the unsupported span in bending, and is not to be less than 2.5 times the depth of the slots if the slots are not closed.

3.6.3.5 Scantlings of corrugated bulkheads are to comply with the requirements in 3.9.4.

3.7 Superstructure

3.7.1 Forecastle structure

3.7.1.1 Forecastle structures are to be supported by girders with deep beams and web frames, and in general, arranged in complete transverse belts and supported by lines of pillars extending down into the structure below. Deep beams and girders are to be arranged, where practicable, to limit the spacing between deep beams, web frames, and/or girders to about 3.5m. Pillars are to be provided as required by 3.4.4. Main structural intersections are to be carefully developed with special attention given to pillar head and heel connections, and to the avoidance of stress concentrations.

3.7.2 Forecastle end bulkhead

3.7.2.1 The details and scantlings of the forecastle end bulkhead are to meet the requirements of Section 11/1.4.

3.8 Miscellaneous Structures

3.8.1 Pillar bulkheads

3.8.1.1 Bulkheads that support girders, or pillars and longitudinal bulkheads which are fitted in lieu of girders, are to be stiffened to provide supports not less effective than required for stanchions or pillars. The acting load and the required net cross sectional area of the pillar section are to be determined using the requirements of 3.4.4. The net moment of inertia of the stiffener is to be calculated with a width of $40t_{net}$, where t_{net} is the net thickness of plating, in mm.

3.8.1.2 Pillar bulkheads are to comply with the following requirements:

- (a) the distance between bulkhead stiffeners is not to exceed 1500mm
- (b) where corrugated, the depth of the corrugation is not to be less than 100mm.

3.8.2 Bulbous bow

3.8.2.1 Where a bulbous bow is fitted, the structural arrangements are to be such that the bulb is adequately supported and integrated into the fore peak structure.

3.8.2.2 At the forward end of the bulb the structure is generally to be supported by horizontal diaphragm plates spaced about 1m apart in conjunction with a deep centreline web.

3.8.2.3 In general, vertical transverse diaphragm plates are to be arranged in way of the transition from the peak framing to the bulb framing.

3.8.2.4 In way of a wide bulb, additional strengthening in the form of a centreline wash bulkhead is generally to be fitted.

3.8.2.5 In way of a long bulb, additional strengthening in the form of transverse wash bulkheads or substantial web frames is to be fitted.

3.8.2.6 The shell plating is to be increased in thickness at the forward end of the bulb and also in areas likely to be subjected to contact with anchors and chain cables during anchor handling. The increased plate thickness is to be the same as that required for plated stems given in 3.2.6.

3.8.3 Chain lockers

3.8.3.1 Chain lockers are to meet the requirements of Section 11/4.2.9.

3.8.4 Bow thruster tunnels

3.8.4.1 The net thickness of the tunnel plating, $t_{tun-net}$ is not to be less than as required for the shell plating in the vicinity of the bow thruster. In addition, $t_{tun-net}$ is not to be taken less than:

$$t_{tun-net} = 0.008d_{tun} + 1.8 \quad (mm)$$

Where:

d_{inn} : inside diameter of the tunnel, in *mm*, but not to be taken less than 970*mm*

3.8.4.2 Where the outboard ends of the tunnel are provided with bars or grids, the bars or grids are to be effectively secured.

3.9 Scantling Requirements

3.9.1 General

3.9.1.1 The design load sets are to be applied to the structural requirements for the local support and primary support members as given in **Table 8.3.8**. The static and dynamic load components are to be combined in accordance with **Table 7.6.1** and the procedure given in **Section 7/6.3**.

3.9.2 Plating and local support members

3.9.2.1 For plating subjected to lateral pressure, the net plating thickness, t_{net} , is to be taken as the greatest value calculated for all applicable design load sets, as given in **Table 8.3.8**, and given by:

$$t_{net} = 0.0158\alpha_p s \sqrt{\frac{|P|}{C_a \sigma_{yd}}} \quad (mm)$$

Where:

α_p : correction factor for the panel aspect ratio

$$= 1.2 - \frac{s}{2100l_p}, \text{ but not to be greater than } 1.0$$

P : design pressure for the design load set being considered, calculated at the load calculation point defined in **Section 3/5.1.2**, in kN/m^2

s : stiffener spacing, in *mm*, as defined in **Section 4/2.2**

l_p : length of plate panel, to be taken as the spacing of primary support members, unless carlings are fitted, in *m*

C_a : permissible bending stress coefficient for the acceptance criteria set being considered, as given in **Table 8.3.2**

σ_{yd} : specified minimum yield stress of the material, in N/mm^2

Table 8.3.2 Permissible Bending Stress Coefficient for Plating

Acceptance criteria set	Structural member	C_a
AC1	All plating	0.80
AC2	Hull envelope plating	0.95
	Internal boundary plating ⁽¹⁾	1.00

Note

1. Collision bulkhead plating is to be evaluated for design load set 11 (accidental flooding) using acceptance criteria set AC1

3.9.2.2 For stiffeners subjected to lateral pressure, the net section modulus, Z_{net} , is to be taken as the greatest value calculated for all applicable design load sets, as given in **Table 8.3.8**, and given by:

$$Z_{net} = \frac{|P|s l_{bdg}^2}{f_{bdg} C_s \sigma_{yd}} \quad (cm^3)$$

Where:

P : design pressure for the design load set being considered, calculated at the load calculation point defined in **Section 3/5.2.2**, in kN/m^2

s : stiffener spacing, in *mm*, as defined in **Section 4/2.2**

l_{bdg} : effective bending span, as defined in **Section 4/2.1.1**, in *m*

f_{bdg} : bending moment factor

for continuous stiffeners and where end connections are fitted consistent with idealisation of the stiffener as having fixed ends

12. for horizontal stiffeners

10. for vertical stiffeners

for other configurations the bending moment factor may be taken as in

Table 8.3.5.

C_s : permissible bending stress coefficient for the acceptance criteria set being considered, as given in **Table 8.3.3**

σ_{yd} : specified minimum yield stress of the material, in N/mm^2

Table 8.3.3 Permissible Bending Stress Coefficient for Stiffeners

Acceptance criteria set	Structural member	C_s
AC1	All stiffeners	0.75
AC2	All stiffeners ⁽¹⁾	0.90

Note

1. Collision bulkhead stiffeners are to be evaluated for design load set 11 (accidental flooding) using acceptance criteria set AC1

3.9.2.3 For stiffeners subjected to lateral pressure, the net web thickness based on shear area requirements, t_{w-net} , is to be taken as the greatest value calculated for all applicable design load sets, as given in **Table 8.3.8**, and given by:

$$t_{w-net} = \frac{f_{shr} |P| s l_{shr}}{d_{shr} C_t \tau_{yd}} \quad (mm)$$

Where:

P : design pressure for the design load set being considered, calculated at the load calculation point defined in **Section 3/5.2.2**, in kN/m^2

f_{shr} : shear force factor

for continuous stiffeners and where end connections are fitted consistent with idealisation of the stiffener as having fixed ends:

0.5 for horizontal stiffeners

0.7 for vertical stiffeners

for other configurations the shear force factor may be taken as in **Table 8.3.5.**

s : stiffener spacing, in mm , as defined in **Section 4/2.2**

l_{shr} : effective shear span, as defined in **Section 4/2.1.2**, in m

d_{shr} : effective web depth of stiffeners, in mm , as defined in **Section 4/2.4.2.2**

C_t : permissible shear stress coefficient for the acceptance criteria set being considered, as given in **Table 8.3.4**

$$\tau_{yd} = \frac{\sigma_{yd}}{\sqrt{3}} \quad (N/mm^2)$$

σ_{yd} : specified minimum yield stress of the material, in N/mm^2

Table 8.3.4 Permissible Shear Stress Coefficient for Stiffeners

Acceptance criteria set	Structural member	C_t
AC1	All stiffeners	0.75
AC2	All stiffeners ⁽¹⁾	0.90

Note

1. Collision bulkhead stiffeners are to be evaluated for design load set 11 (accidental flooding) using acceptance criteria set AC1

Table 8.3.5 Bending Moment and Shear Force Factors, f_{bdg} and f_{shr}

Load and boundary condition				Bending moment and shear force factor (based on load at mid span, where load varies)		
Position				1	2	3
Load model	1 Support	2 Field	3 Support	f_{bdg1} f_{shr1}	f_{bdg2} -	f_{bdg3} f_{shr3}
A				12.0 0.50	24.0 -	12.0 0.50
B				- 0.38	14.2 -	8.0 0.63
C				- 0.50	8.0 -	- 0.50
D				15.0 0.30	23.3 -	10.0 0.70
E				- 0.20	16.8 -	7.5 0.80

Note

- The bending moment factor f_{bdg} for the support positions are applicable for a distance of $0.2l_{bdg}$ from the end of the effective bending span for both local and primary support members.
- The shear force factor f_{shr} for the support positions are applicable for a distance of $0.2l_{shr}$ from the end of the effective shear span for both local and primary support members.
- Application of f_{bdg} and f_{shr} for local support members:
 - the section modulus requirement of local support members is to be determined using the lowest value of f_{bdg1} , f_{bdg2} and f_{bdg3}
 - the shear area requirement of local support members is to be determined using the greatest value of f_{shr1} and f_{shr3} .
- Application of f_{bdg} and f_{shr} for primary support members:
 - the section modulus requirement within $0.2l_{bdg}$ from the end of the effective span is generally to be determined using the applicable f_{bdg1} and f_{bdg3} , however f_{bdg} is not to be taken greater than 12
 - the section modulus of mid span area is to be determined using $f_{bdg} = 24$, or f_{bdg2} from the table if lesser
 - the shear area requirement of end connections within $0.2l_{shr}$ from the end of the effective span is to be determined using $f_{shr} = 0.5$ or the applicable f_{shr1} or f_{shr3} , whichever is greater
 - for models A through E the value of f_{shr} may be gradually reduced outside of $0.2l_{shr}$ towards $0.5f_{shr}$ at mid span where f_{shr} is the greater value of f_{shr1} and f_{shr3} .
- For other load models see **Table 8.7.1**.

3.9.3 Primary support members

3.9.3.1 For primary support members intersecting with or in way of curved hull sections, the effectiveness of end brackets is to include allowance for the curvature of the hull. For side transverse frames, the requirements may be reduced due to the presence of cross ties, see **3.3.3.4**.

3.9.3.2 For primary support members subjected to lateral pressure, the net section modulus, Z_{net50} , is to be taken as the greatest value for all applicable design load sets, as given in **Table 8.3.8**, and given by:

$$Z_{net50} = 1000 \frac{|P| S l_{bdg}^2}{f_{bdg} C_s \sigma_{ydl}} \quad (cm^3)$$

Where:

- P : design pressure for the design load set being considered, calculated at the load calculation point defined in **Section 3/5.3.3**, in kN/m^2
 S : primary support member spacing, in m , as defined in **Section 4/2.2.2**
 l_{bdg} : effective bending span, as defined in **Section 4/2.1.4**, in m
 f_{bdg} : bending moment factor, as given in **Table 8.3.5**
 C_s : permissible bending stress coefficient for the acceptance criteria set being considered, as given in **Table 8.3.6**
 σ_{yd} : specified minimum yield stress of the material, in N/mm^2

Table 8.3.6 Permissible Bending Stress Coefficient for Primary Support Members

Acceptance criteria set	Structure attached to primary support member	C_s
AC1	All boundaries, including decks and flats	0.70
AC2	All boundaries, including decks and flats ⁽¹⁾	0.85

Note

1. Collision bulkhead primary support members are to be evaluated for design load set 11 (accidental flooding) using acceptance criteria set AC1

3.9.3.3 For primary support members subjected to lateral pressure, the effective net shear area, $A_{shr-net50}$, is to be taken as the greatest value for all applicable design load sets, as given in **Table 8.3.8**, and given by:

$$A_{shr-net50} = 10 \frac{f_{shr} |P| S l_{shr}}{C_t \tau_{yd}} \quad (cm^2)$$

Where:

- P : design pressure for the design load set being considered, calculated at the load calculation point defined in **Section 3/5.3.2**, in kN/m^2
 S : primary support member spacing, in m , as defined in **Section 4/2.2.2**
 l_{shr} : effective shear span, as defined in **Section 4/2.1.5**, in m
 f_{shr} : shear force factor, as given in **Table 8.3.5**
 C_t : permissible shear stress coefficient for the acceptance criteria set being considered, as given in **Table 8.3.7**
 $\tau_{yd} = \frac{\sigma_{yd}}{\sqrt{3}}$ (N/mm^2)
 σ_{yd} : specified minimum yield stress of the material, in N/mm^2

Table 8.3.7 Permissible Shear Stress Coefficient for Primary Support Members

Acceptance criteria set	Structure attached to primary support member	C_t
AC1	All boundaries, including decks and flats	0.70
AC2	All boundaries, including decks and flats ⁽¹⁾	0.85

Note

1. Collision bulkhead primary support members are to be evaluated for design load set 11 (accidental flooding) using acceptance criteria set AC1

3.9.3.4 Primary support members are to generally be analysed with the specific methods as described for the particular structure type. More advanced calculation methods may be necessary to ensure that nominal stress level for all primary support members are less than the permissible stresses and stress coefficients given in **3.9.3.2** and **3.9.3.3** when subjected to the applicable design load sets.

3.9.4 Corrugated bulkheads

3.9.4.1 Special consideration will be given to the approval of corrugated bulkheads where fitted.

Guidance Note

Scantling requirements of corrugated bulkheads in the cargo tank region may be used as a basis, see **2.5.6** and **2.5.7**.

3.9.5 Pillars

3.9.5.1 The maximum load on a pillar, W_{pill} , is to be taken as the greatest value calculated for all applicable design load sets, as given in **Table 8.3.8**, and is to be less than or equal to the permissible pillar load as given by the following equation, where $W_{pill-perm}$ is based on the net properties of the pillar.

$$W_{pill} \leq W_{pill-perm}$$

Where:

$$W_{pill} : \text{applied axial load on pillar} \\ = P b_{a-sup} l_{a-sup} + W_{pill-upr} \quad (kN)$$

$$W_{pill-perm} : \text{permissible load on a pillar} \\ = \frac{A_{pill-net50} \eta_{pill} \sigma_{crb}}{10} \quad (kN)$$

P : design pressure for the design load set being considered, calculated at centre of the deck area supported by the pillar being considered, in kN/m^2

b_{a-sup} : mean breadth of area supported, in m

l_{a-sup} : mean length of area supported, in m

$W_{pill-upr}$: axial load from pillar or pillars above, in kN

$A_{pill-net50}$: net cross section area of the pillar, in cm^2

η_{pill} : utilisation factor for the design load set being considered

= 0.5 for acceptance criteria set AC1

= 0.6 for acceptance criteria set AC2

σ_{crb} : critical buckling stress in compression of pillar based on the net sectional properties calculated in accordance with **Section 10/3.5.1**, in N/mm^2

Table 8.3.8 Design Load Sets for Plating, Local Support Members and Primary Support Members

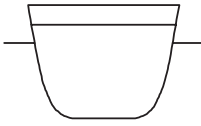
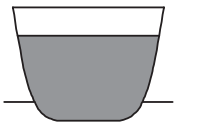
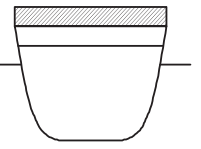
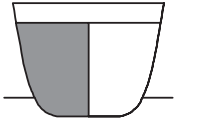
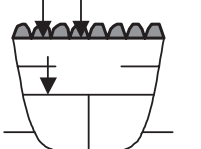
Type of Local Support and Primary Support Member	Design Load Set ⁽¹⁾	Load Component	External Draught	Comment	Diagrammatic Representation
Shell Envelope	1	P_{ex}	T_{sc}	Sea pressure only	
	2	P_{ex}	T_{sc}		
	5	P_{in}	T_{bal}	Tank pressure only. Sea pressure to be ignored	
	6	P_{in}	$0.25T_{sc}$		
External Decks	1	P_{ex}	T_{sc}	Green sea pressure only	
Tank Boundaries and/or Watertight Boundaries	5	P_{in}	T_{bal}	Pressure from one side only Full tank with adjacent tank empty	
	6	P_{in}	$0.25T_{sc}$		
	11	$P_{in-flood}$	-		
Internal and External Decks or Flats	9	P_{dk}	T_{bal}	Distributed or concentrated loads only. Adjacent tanks empty. Green sea pressure may be ignored	
	10	P_{dk}	T_{bal}		

Where:

T_{sc} scantling draught, in m , as defined in Section 4/1.1.5.5

T_{bal} minimum design ballast draught, in m , as defined in Section 4/1.1.5.2

Notes

- The specification of design load combinations and other load parameters for the design load sets are given in **Table 8.2.8**
- When the ship's configuration cannot be described by the above, then the applicable Design Load Sets to determine the scantling requirements of structural boundaries are to be selected so as to specify a full tank on one side with the adjacent tank or space empty. The boundary is to be evaluated for loading from both sides. Design Load Sets are to be selected based on the tank or space contents and are to maximise the pressure on the structural boundary, the draught to use is to be taken in accordance with the Design Load Set and this table. Design Load Sets covering the S and S+D design load combinations are to be selected. See **Note 4** on **Table 8.2.7** and **Table 8.2.8**.
- The boundaries of void and dry space not forming part of the hull envelope are to be evaluated using Design Load Set 11. See **Note 2**.

4. Machinery Space

4.1 General

4.1.1 Application

4.1.1.1 The requirements of this Sub-Section apply to machinery spaces situated in the aft end region, aft of the aftermost cargo tank bulkhead and forward of, and including, the aft peak bulkhead.

4.1.1.2 The net scantlings described in this Sub-Section are related to gross scantlings as follows:

- (a) for application the minimum thickness requirements of **4.1.5**, the gross thickness is obtained from the applicable requirements by adding the full corrosion additions as specified in **Section 6/3**.
- (b) for plating and local support members, the gross thickness and gross cross sectional properties are obtained from the applicable requirements by adding the full corrosion additions as specified in **Section 6/3**.
- (c) for primary support members, the gross shear area, gross section modulus and other gross cross sectional properties are obtained from the applicable requirements by adding one half of the relevant full corrosion additions as specified in **Section 6/3**.
- (d) for application of buckling requirements of **Section 10/2** the gross thickness and gross cross sectional properties are obtained from the applicable requirements by adding the full corrosion additions as specified in **Section 6/3**.

4.1.2 General scantling requirements

4.1.2.1 The hull structure is to comply with the applicable requirements of:

- (a) hull girder longitudinal strength, see **Section 8/1**
- (b) strength against sloshing and impact loads, see **Section 8/6**
- (c) buckling/ultimate strength, see **Section 10**.

4.1.2.2 The net section modulus, shear area and other sectional properties of local and primary support members are to be determined in accordance with **Section 4/2**.

4.1.2.3 The section modulus and web thickness of the local support members apply to the areas clear of the end brackets. The section modulus and cross sectional shear areas of the primary support members are to be applied as required in the notes to **Table 8.3.5**.

4.1.2.4 The scantling criteria are based on assumptions that all structural joints and welded details are designed and fabricated such that they are compatible with the anticipated working stress levels at the locations considered. The loading patterns, stress concentrations and potential failure modes of structural joints and details during the design of highly stressed regions are to be considered. Structure design details are to comply with the requirements in **Section 4/3**.

4.1.2.5 Limber, drain and air holes are to be cut in all parts of the structure, as required, to ensure the free flow to the suction pipes and the escape of air to the vents. Arrangements are to be made for draining the spaces above tanks. See also **Section 4/3**.

4.1.3 Structural continuity

4.1.3.1 Scantlings of the shell envelope, upper deck and inner bottom are to be properly tapered towards the aft end. See also **1.6**.

4.1.3.2 Suitable arrangements are to be made to ensure continuity of strength and the avoidance of abrupt discontinuities when structure that contributes to the main longitudinal strength of the ship is omitted in way of the machinery space.

4.1.3.3 Where inner hull or longitudinal bulkhead structures terminate at the forward engine room bulkhead, adequate backing structure is to be provided together with tapering brackets to ensure continuity of strength.

4.1.3.4 All shell frames and tank boundary stiffeners are to be continuous throughout, or are to be bracketed at their ends, except as permitted in **Sections 4/3.2.4** and **4/3.2.5**.

4.1.3.5 Longitudinal primary support members, lower decks, and bulkheads arranged in the engine room are to be aligned with similar structures in the cargo tank region, as far as practicable. Where direct alignment is not possible, suitable scarphing arrangements such as taper brackets are to be provided.

4.1.4 Arrangements

4.1.4.1 Where openings in decks/bulkheads are provided in the machinery space, the arrangements are to ensure support for deck, side, and bottom structure.

4.1.4.2 All parts of the machinery, shafting, etc., are to be supported to distribute the loads into the ship's structure. The adjacent structure is to be suitably stiffened.

4.1.4.3 Primary support members are to be positioned giving consideration to the provision of through stiffeners and in-line pillar supports to achieve an efficient structural design.

4.1.4.4 These requirements are formulated assuming conventional single screw, single engine propulsion arrangements. Twin-screw or multi-engine vessels, or vessels of higher power, may require additions to the scantlings of the structure and the area of attachments, which are proportional to the weight, power and proportions of the machinery especially where the engines are positioned relatively high in proportion to the width of the bed plate.

4.1.4.5 The foundations for main propulsion units, reduction gears, shaft and thrust bearings, and the structure supporting those foundations are to maintain the required alignment and rigidity under all anticipated conditions of loading. Consideration is to be given to the submittal of the following plans to the machinery manufacturer for review:

- (a) foundations for main propulsion units
- (b) foundations for reduction gears
- (c) foundations for thrust bearings
- (d) structure supporting (a), (b) and (c).

4.1.4.6 A cofferdam is to be provided to separate the cargo tanks from the machinery space. Pump room, ballast tanks, or fuel oil tanks may be considered as cofferdams for this purpose.

4.1.5 Minimum thickness

4.1.5.1 In addition to the requirements for thickness, section modulus and shear area, as given in 4.2 to 4.8, the thickness of plating and stiffeners in the machinery space is to comply with applicable minimum thickness requirements given in **Table 8.4.1**.

Table 8.4.1 Minimum Net Thickness of Structure in the Machinery Space

Scantling Location		Net Thickness (mm)	
Plating	Shell	Keel plating	See 2.1.5.1
		Bottom shell/bilge/side shell plating	See 2.1.5.1
	Upper Deck		See 2.1.5.1
	Other structure	Hull internal tank boundaries	See 2.1.5.1
		Non-tight bulkheads, bulkheads between dry spaces and other plates in general	See 2.1.5.1
		Lower decks and flats	$3.3 + 0.0067s$
		Inner bottom	$6.5 + 0.02L_2$
	Bottom centreline girder		See 2.1.6.1
Floors and bottom longitudinal girders off centreline		$5.5 + 0.02 L_2$	
Web plating of primary support members		$5.5 + 0.015 L_2$	
Local support members		See 2.1.5.1	
Tripping brackets		See 2.1.5.1	

Where:

L_2 : rule length, L_{CSR-T} , as defined in **Section 4/1.1.1.1**, but need not be taken greater than 300m

s : stiffener spacing, in mm, as defined in **Section 4/2.2**

4.2 Bottom Structure

4.2.1 General

4.2.1.1 In general, a double bottom is to be fitted in the machinery space. The depth of the double bottom is to be at least the same as required in the cargo tank region, see **Section 5/3.2.1**. Where the depth of the double bottom in the machinery space differs from that in the adjacent spaces, continuity of the longitudinal material is to be maintained by sloping the inner bottom over a suitable longitudinal extent. Lesser double bottom height may be accepted in local areas provided that the overall strength of the double bottom structure is not thereby impaired.

4.2.2 Bottom shell plating

4.2.2.1 The keel plate breadth is to comply with the requirements in **Section 8/2.2.1.1**.

4.2.2.2 The thickness of the bottom shell plating (including keel plating) is to comply with the requirements in **4.8.1.1**.

4.2.3 Bottom shell stiffeners

4.2.3.1 The section modulus and thickness of bottom shell stiffeners are to comply with the requirements in **4.8.1.2** and **4.8.1.3**.

4.2.4 Girders and floors

4.2.4.1 The double bottom is to be arranged with a centreline girder.

4.2.4.2 Full depth bottom girders are to be arranged in way of the main machinery to effectively distribute its weight, and to ensure rigidity of the structure. The girders are to be carried as far forward and aft as practicable, and suitably supported at their ends to provide distribution of loads from the machinery. The girders are to be tapered beyond their required extent.

4.2.4.3 Where fitted, side girders are to align with the bottom side girders in the adjacent space.

4.2.4.4 Where the double bottom is transversely framed, plate floors are to be fitted at every frame.

4.2.4.5 Where the double bottom is longitudinally framed, plate floors are to be fitted at every frame under the main engine and thrust bearing. Outboard of the engine and bearing seatings, the floors may be fitted at alternate frames.

4.2.4.6 Where heavy equipment is mounted directly on the inner bottom, the thickness of the floors and girders is to be suitably increased.

4.2.5 Inner bottom plating

4.2.5.1 Where main engines or thrust bearings are bolted directly to the inner bottom, the net thickness of the inner bottom plating is to be at least 19mm. Hold-down bolts are to be arranged as close as possible to floors and longitudinal girders. Plating thickness and the arrangements of hold-down bolts are also to consider the manufacturer's recommendations.

4.2.6 Sea chests

4.2.6.1 Where the inner bottom or double bottom structure forms part of a sea chest, the thickness of the plating is not to be less than that required for the shell at the same location, taking into account the maximum unsupported width of the plating.

4.3 Side Structure

4.3.1 General

4.3.1.1 The scantlings of the side shell plating and longitudinals are to be properly tapered from the midship region towards the aft end.

4.3.1.2 A suitable scarphing arrangement of the longitudinal framing is to be arranged where the longitudinal framing terminates and is replaced by transverse framing.

4.3.1.3 Stiffeners and primary support members are to be supported at their ends.

4.3.2 Side shell plating

4.3.2.1 The thickness of the side shell plating is to comply with the requirements in **4.8.1.1**. Where applicable, the thickness of the side shell plating is to comply with the requirements in **2.2.4.2**.

4.3.3 Side shell local support members

4.3.3.1 The section modulus and thickness of side longitudinal and vertical stiffeners are to comply with the requirements in **4.8.1.2** and **4.8.1.3**.

4.3.3.2 End connections of longitudinals at transverse bulkheads are to provide fixity, lateral support, and when not continuous are to be provided with soft-nosed brackets. Brackets lapped onto the longitudinals are not to be fitted.

4.3.4 Side shell primary support members

4.3.4.1 Web frames are to be connected at the top and bottom to members of suitable stiffness, and supported by deck transverses.

4.3.4.2 The spacing of web frames in way of transversely framed machinery spaces is generally not to exceed five transverse frame spaces.

4.3.4.3 The section modulus and shear area of primary support members are to comply with the requirements in **4.8.2**.

4.3.4.4 The web depth is to be not less than 2.5 times the web depth of the adjacent frames if the slots are not closed.

4.3.4.5 Web plating of primary support members is to have a depth of not less than 14% of the unsupported span in bending.

4.4 Deck Structure**4.4.1 General**

4.4.1.1 All openings are to be framed. Attention is to be paid to structural continuity. Abrupt changes of shape, section or plate thickness are to be avoided.

4.4.1.2 The corners of the machinery space openings are to be of suitable shape and design to minimise stress concentrations.

4.4.1.3 In way of machinery openings, deck or flats are to have sufficient strength where they are intended as effective supports for side transverse frames or web frames.

4.4.1.4 Where a transverse framing system is adopted, deck stiffeners are to be supported by a suitable arrangement of longitudinal girders in association with pillars or pillar bulkheads. Where fitted, deck transverses are to be arranged in line with web frames to provide end fixity and transverse continuity of strength.

4.4.1.5 Where a longitudinal framing system is adopted, deck longitudinals are to be supported by deck transverses in line with web frames in association with pillars or pillar bulkheads.

4.4.1.6 Machinery casings are to be supported by a suitable arrangement of deck transverses and longitudinal girders in association with pillars or pillar bulkheads. In way of particularly large machinery casing openings, cross ties may be required. These are to be arranged in line with deck transverses.

4.4.1.7 The structural scantlings are to be not less than the requirement for tank boundaries if the deck forms the boundary of a tank.

4.4.1.8 The structural scantlings are to be not less than the requirement for watertight bulkheads if the deck forms the boundary of a watertight space.

4.4.2 Deck scantlings

4.4.2.1 The plate thickness of deck plating is to comply with the requirements in **4.8.1.1**.

4.4.2.2 The section modulus and thickness of deck stiffeners are to comply with the requirements in **4.8.1.2** and **4.8.1.3**.

4.4.2.3 The web depth of deck stiffeners is to be not less than 60mm.

4.4.2.4 The section modulus and shear area of primary support members are to comply with the requirements in **4.8.2**.

4.4.2.5 The web depth of primary support members is not to be less than 10% and 7% of the unsupported span in bending in tanks and in dry spaces, respectively, and is not to be less than 2.5 times the depth of the slots if the slots are not closed. Unsupported span in bending is bending span as defined in **Section 4/2.1.4** or in case of a grillage structure the distance between connections to other primary support members.

4.4.2.6 In way of concentrated loads from heavy equipment, the scantlings of the deck structure are to be determined based on the actual loading.

4.4.3 Pillars

4.4.3.1 Pillars are to be fitted in the same vertical line wherever possible, and effective arrangements are to be made to distribute the load at the heads and heels of all pillars. Where pillars support eccentric loads, they are to be strengthened for the additional bending moment imposed upon them.

4.4.3.2 Tubular and hollow square pillars are to be attached at their heads and heels by efficient brackets, or doublers/insert plates, where applicable, to transmit the load effectively. Pillars are to be attached at their heads and heels by continuous welding. At the heads and heels of pillars built of rolled sections, the load is to be distributed by brackets or other equivalent means.

4.4.3.3 In double bottoms under widely spaced pillars, the connections of the floors to the girders, and of the floors and girders to the inner bottom, are to be suitably increased. Where pillars are not directly above the intersection of plate floors and girders, partial floors and intercostals are to be fitted as necessary to support the pillars. Manholes are not to be cut in the floors and girders below the heels of pillars.

4.4.3.4 Pillars in tanks are to be of solid section. Where the hydrostatic pressure may result in tensile stresses in the pillar, the tensile stress in the pillar and its end connections is not to exceed 45% of the specified minimum yield stress of the material.

4.4.3.5 The scantlings of pillars are to comply with the requirements in **3.9.5**.

4.4.3.6 Where the pillar loads from heavy equipment exceed the design load required by **3.9.5**, the pillar scantlings are to be determined based on the actual loading.

4.5 Machinery Foundations

4.5.1 General

4.5.1.1 Main engines and thrust bearings are to be effectively secured to the hull structure by foundations of strength that is sufficient to resist the various gravitational, thrust, torque, dynamic, and vibratory forces which may be imposed on them.

4.5.1.2 In the case of higher power internal combustion engines or turbine installations, the foundations are generally to be integral with the double bottom structure. Consideration is to be given to substantially increase the inner bottom plating thickness in way of the engine foundation plate or the turbine gear case, and the thrust bearing, see **Fig. 8.4.1**, Type 1.

4.5.1.3 For main machinery supported on foundations of Type 2, as shown in **Fig. 8.4.1**, the forces from the engine into the adjacent structure are to be distributed as uniformly as possible. Longitudinal members supporting the foundation are to be aligned with girders in the double bottom, and transverse stiffening is to be arranged in line with the floors, see **Fig. 8.4.1**, Type 2.

4.5.1.4 For ships with open floors in the machinery space, the foundations are generally to be arranged above the level of the top of the floors and securely bracketed, see **Fig. 8.4.1**, Type 3.

Fig. 8.4.1 Machinery Foundations

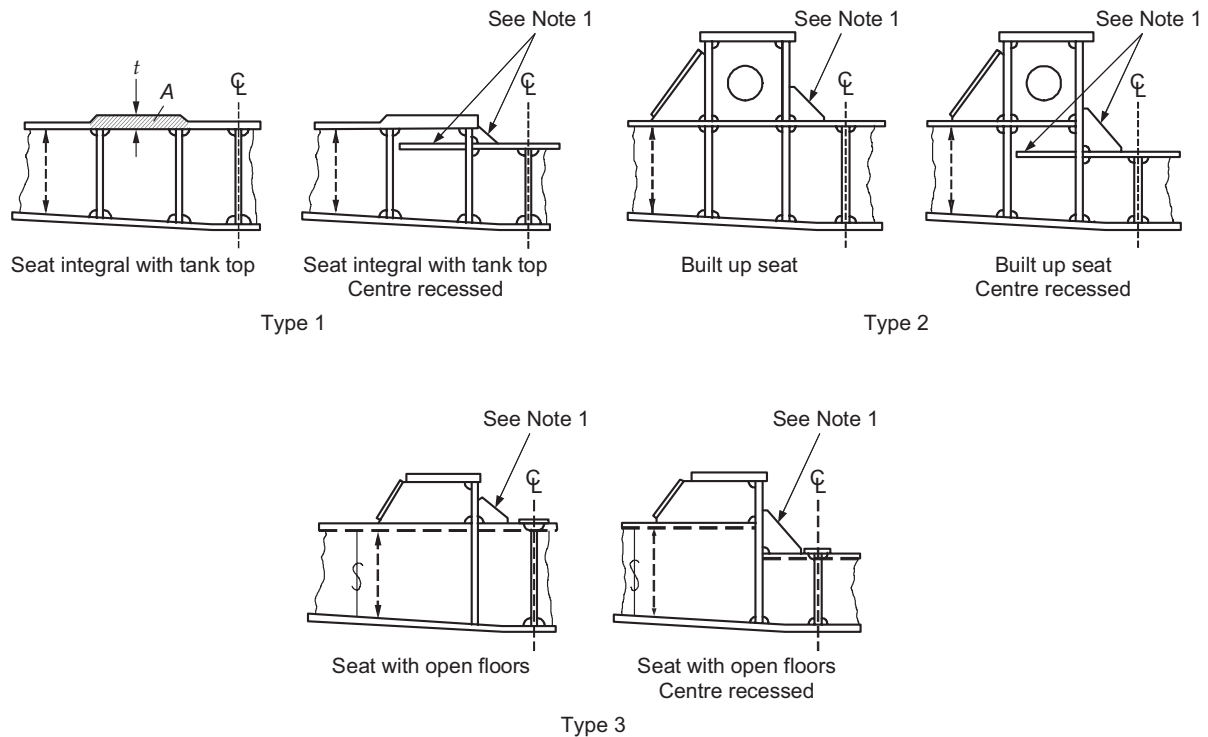

Note

1. Brackets are to be as large as possible. Brackets may be omitted to avoid interference with the girders of the engine foundation, in accordance with recommendations of the engine manufacturer.

4.5.2 Foundations for internal combustion engines and thrust bearings

4.5.2.1 In determining the scantlings of foundations for internal combustion engines and thrust bearings, consideration is to be given to the general rigidity of the engine and to its design characteristics with regard to out of balance forces.

4.5.2.2 Generally two girders are to be fitted in way of the foundation for internal combustion engines and thrust bearings.

Guidance Note

In general, the gross thickness of foundation top plates is not to be less than 45mm , where the maximum continuous output of the propulsion machinery is 3500kW or greater.

4.5.3 Auxiliary foundations

4.5.3.1 Auxiliary machinery is to be secured on foundations that are of suitable size and arrangement to distribute the loads from the machinery evenly into the supporting structure.

4.6 Tank Bulkheads

4.6.1 General

4.6.1.1 Tanks may be required to have divisions or deep wash plates to minimise the dynamic stress on the structure.

4.6.2 Construction

4.6.2.1 In no case are the scantlings of tank boundary bulkheads to be less than the requirements for watertight bulkheads.

4.6.3 Scantlings of tank boundary bulkheads

4.6.3.1 The thickness of tank boundary plating is to comply with the requirements in 4.8.1.1.

4.6.3.2 The section modulus and thickness of stiffeners are to comply with the requirements in 4.8.1.2 and 4.8.1.3.

4.6.3.3 The section modulus and shear area of primary support members are to comply with the requirements in **4.8.2**.

4.6.3.4 Web plating of primary support members is to have a depth of not less than 14% of the unsupported span in bending and not less than 2.5 times the depth of the slots if the slots are not closed.

4.7 Watertight Boundaries

4.7.1 General

4.7.1.1 Watertight boundaries within the machinery space are to be fitted in accordance with **Section 5/2**.

4.7.2 Scantlings of watertight boundaries

4.7.2.1 The thickness of watertight boundary plating is to comply with the requirements in **4.8.1.1**.

4.7.2.2 The section modulus and thickness of stiffeners are to comply with the requirements in **4.8.1.2** and **4.8.1.3**.

4.7.2.3 The section modulus and shear area of primary support members are to comply with the requirements in **4.8.2**.

4.7.2.4 Web plating of primary support members is to have a depth of not less than 10% of the unsupported span in bending and not less than 2.5 times the depth of the slots if the slots are not closed.

4.8 Scantling Requirements

4.8.1 Plating and local support members

4.8.1.1 For plating subjected to lateral pressure the net plating thickness is to comply with the requirements in **3.9.2.1**, but using the permissible bending stress coefficient, C_a , defined in **Table 8.4.2**.

4.8.1.2 For stiffeners subjected to lateral pressure the net section modulus requirement is to comply with the requirements in **3.9.2.2**, but using the permissible bending stress coefficient, C_s , defined in **Table 8.4.3**.

4.8.1.3 For stiffeners subjected to lateral pressure the net web thickness based on shear area requirements is to comply with the requirements in **3.9.2.3**.

Table 8.4.2 Permissible Bending Stress Coefficient for Plating

The permissible bending stress coefficient, C_a , for the design load set being considered is to be taken as:						
$C_a = \beta_a - a_a \frac{ \sigma_{hg} }{\sigma_{yd}}$ but not to be taken greater than C_{a-max}						
Where:						
$\beta_a, \alpha_a, C_{a-max}$	Acceptance Criteria Set	Structural Member		β_a	α_a	C_{a-max}
AC1	Longitudinal Strength Members	Longitudinally stiffened plating		0.9	0.5	0.8
		Transversely or vertically stiffened plating		0.9	1.0	0.8
	Other members		0.8	0	0.8	
AC2	Longitudinal Strength Members	Longitudinally stiffened plating		1.05	0.5	0.95
		Transversely or vertically stiffened plating		1.05	1.0	0.95
	Other members, including watertight boundary plating		1.0	0	1.0	
σ_{hg}	: hull girder bending stress for the design load set being considered and calculated at the load calculation point defined in Section 3/5.1.2 $= \frac{(z - z_{NA-net50}) M_{v-total}}{I_{v-net50}} 10^{-3} \quad N/mm^2$					
$M_{v-total}$: design vertical bending moment at the longitudinal position under consideration for the design load set being considered, in kNm . The still water bending moment, $M_{sw-perm}$, is to be taken with the same sign as the simultaneously acting wave bending moment, M_{wv} , see Table 7.6.1					
$I_{v-net50}$: net vertical hull girder moment of inertia, at the longitudinal position being considered, as defined in Section 4/2.6.1 , in m^4					
z	: vertical coordinate of the load calculation point under consideration, in m					
$z_{NA-net50}$: distance from the baseline to the horizontal neutral axis, as defined in Section 4/2.6.1 , in m					
σ_{yd}	: specified minimum yield stress of the material, in N/mm^2					

Table 8.4.3 Permissible Bending Stress Coefficient for Stiffeners

The permissible bending stress coefficient C_s is to be taken as:

Sign of Hull Girder Bending Stress, σ_{hg}	Side that Pressure is Acting On	Acceptance Criteria
Tension (+ve)	Stiffener side	$C_s = \beta_s - \alpha_s \frac{ \sigma_{hg} }{\sigma_{yd}}$ but not to be taken greater than C_{s-max}
Compression (-ve)	Plate side	
Tension (+ve)	Plate side	$C_s = C_{s-max}$
Compression (-ve)	Stiffener side	

Where:
 $\beta_s, \alpha_s, C_{s-max}$ permissible bending stress factors and are to be taken as:

Acceptance Criteria Set	Structural Member	β _s	α _s	C _{s-max}
AC1	Longitudinally effective stiffeners	0.85	1.0	0.75
	Other stiffeners	0.75	0	0.75
AC2	Longitudinally effective stiffeners	1.0	1.0	0.9
	Other stiffeners	0.9	0	0.9
	Watertight boundary stiffeners	0.9	0	0.9

σ_{hg} : hull girder bending stress for the design load set being considered and calculated at the reference point defined in **Section 3/5.2.2.5**

$$= \left(\frac{(z - z_{NA-net50}) M_{v-total}}{I_{v-net50}} \right) 10^{-3} \quad N/mm^2$$

$M_{v-total}$: design vertical bending moment at longitudinal position under consideration for the design load set being considered, in *kNm*
 $M_{v-total}$ is to be calculated in accordance with **Table 7.6.1** using the sagging or hogging still water bending moment

Stiffener Location	M _{sw-perm}	
	Pressure acting on Plate Side	Pressure acting on Stiffener Side
Above Neutral Axis	Sagging SWBM	Hogging SWBM
Below Neutral Axis	Hogging SWBM	Sagging SWBM

$I_{v-net50}$: net vertical hull girder moment of inertia, at the longitudinal position being considered, as defined in **Section 4/2.6.1**, in *m⁴*

z : vertical coordinate of the reference point defined in **Section 3/5.2.2.5**, in *m*

$z_{NA-net50}$: distance from the baseline to the horizontal neutral axis, as defined in **Section 4/2.6.1**, in *m*

σ_{yd} : specified minimum yield stress of the material, in *N/mm²*

4.8.2 Primary support members

4.8.2.1 For primary support members intersecting with or in way of curved hull sections, the effectiveness of end brackets is to include allowance for the curvature of the hull.

4.8.2.2 For primary support members subjected to lateral pressure the net section modulus requirement is to comply with the requirements in **3.9.3.2**.

4.8.2.3 For primary support members subjected to lateral pressure the net cross sectional area of the web is to comply with the requirements in **3.9.3.3**.

4.8.2.4 Primary support members are to generally be analysed with the specific methods as described for the particular structure type. More advanced calculation methods may be required to ensure that nominal stress level for

all primary support members are less than permissible stresses and stress coefficients given in 3.9.3.2 and 3.9.3.3 when subjected to the applicable design load sets.

4.8.3 Corrugated bulkheads

4.8.3.1 Special consideration will be given to the approval of corrugated bulkheads where fitted.

Guidance Note

Scantling requirements of corrugated bulkheads in the cargo tank region may be used as a basis, see 2.5.6 and 2.5.7.

4.8.4 Pillars

4.8.4.1 The maximum load on a pillar is to be less than the permissible pillar load as given by the requirements in 3.9.5.

5. Aft End

5.1 General

5.1.1 Application

5.1.1.1 The requirements of this Sub-Section apply to structure located between the aft peak bulkhead and the aft end of the ship.

5.1.1.2 The requirements of this Sub-Section do not apply to the following:

- (a) rudder horns
- (b) structures which are not integral with the hull, such as rudders, steering nozzles and propellers
- (c) other appendages permanently attached to the hull.

Where such items are fitted, the requirements of the Society are to be complied with.

5.1.1.3 The net scantlings described in **5.1** to **5.7** are related to gross scantlings as follows:

- (a) for application the minimum thickness requirements of **5.1.4**, the gross thickness is obtained from the applicable requirements by adding the full corrosion additions specified in **Section 6/3**.
- (b) for plating and local support members, the gross thickness and gross cross sectional properties are obtained from the applicable requirements by adding the full corrosion additions specified in **Section 6/3**
- (c) for primary support members, the gross shear area, gross section modulus and other gross cross sectional properties are obtained from the applicable requirements by adding one half of the relevant full corrosion additions specified in **Section 6/3**
- (d) for application of buckling requirements of **Section 10/2** the gross thickness and gross cross sectional properties are obtained from the applicable requirements by adding the full corrosion additions specified in **Section 6/3**.

5.1.2 General scantling requirements

5.1.2.1 The hull structure is to comply with the applicable requirements of:

- (a) hull girder longitudinal strength, see **Section 8/1**
- (b) strength against sloshing and impact loads, see **Section 8/6**
- (c) buckling/ultimate strength, see **Section 10**.

5.1.2.2 The deck plating thickness and supporting structure are to be suitably reinforced for the steering gear, mooring windlasses, and other deck machinery. See **Section 11/3**.

5.1.2.3 The net section modulus, shear area and other sectional properties of local and primary support members are to be determined in accordance with **Section 4/2**.

5.1.2.4 The section modulus and web thickness of the local support members apply to the areas clear of the end brackets. The section modulus and cross sectional shear areas of the primary support members are to be applied as required in the notes to **Table 8.3.5**.

5.1.2.5 The scantling criteria are based on assumptions that all structural joints and welded details are designed and fabricated such that they are compatible with the anticipated working stress levels at the locations considered. The loading patterns, stress concentrations and potential failure modes of structural joints and details during the design of highly stressed regions are to be considered. Structure design details are to comply with the requirements in **Section 4/3**.

5.1.2.6 Limber, drain and air holes are to be cut in all parts of the structure, as required, to ensure the free flow to the suction pipes and the escape of air to the vents. Arrangements are to be made for draining the spaces above deep tanks. See also **Section 4/3**.

5.1.3 Structural continuity

5.1.3.1 Scantlings of the shell envelope, upper deck and inner bottom are to be tapered towards the aft end. See also **1.6**.

5.1.3.2 In transition zones forward of the aft peak into the machinery space, due consideration is to be given to the tapering of primary support members.

5.1.3.3 Longitudinal framing of the strength deck is to be carried aft to the stern.

5.1.3.4 All shell frames and tank boundary stiffeners are in general to be continuous, or are to be bracketed at their ends, except as permitted in **Sections 4/3.2.4** and **4/3.2.5**.

5.1.4 Minimum thickness

5.1.4.1 In addition to the thickness, section modulus and stiffener web shear area requirements as given in **5.2** to **5.7**, the thickness of plating and stiffeners in the aft end region is to comply with the appropriate minimum thickness requirements given in **Table 8.5.1**.

Table 8.5.1 Minimum Net Thickness of Structure Aft of the Aft Peak Bulkhead

Scantling Location			Net Thickness (<i>mm</i>)
Plating	Shell	Keel plating	See 2.1.5.1
		Bottom shell/bilge/side shell plating	See 2.1.5.1
	Upper Deck		See 2.1.5.1
	Other structure	Hull internal tank boundaries	See 2.1.5.1
		Non-tight bulkheads, bulkheads between dry spaces and other plates in general	See 2.1.5.1
		Pillar bulkheads	7.5
Bottom girders and aft peak floors			$5.5 + 0.02L_2$
Web plating of primary support members			$6.5 + 0.015L_2$
Local support members			See 2.1.5.1
Tripping brackets			See 2.1.5.1

Where:

L_2 : rule length, L_{CSR-T} , as defined in **Section 4/1.1.1.1**, but need not be taken greater than 300m

5.2 Bottom Structure

5.2.1 General

5.2.1.1 Floors are to be fitted at each frame space in the aft peak and carried to a height at least above the stern tube. Where floors do not extend to flats or decks they are to be stiffened by flanges at their upper end.

5.2.1.2 The centreline bottom girder is to extend as far aft as is practicable and is to be attached to the stern frame.

5.2.2 Aft peak floors and girders

5.2.2.1 The height of stiffeners, h_{stf} , on the floors and girders are to be not less than:

$$h_{stf} = 80.0 l_{stf} \quad (mm), \text{ for flat bar stiffeners}$$

$$h_{stf} = 70.0 l_{stf} \quad (mm), \text{ for bulb profiles and flanged stiffeners}$$

Where:

l_{stf} : length of stiffener as shown in **Fig. 8.5.1**, in *m*

5.2.2.2 In conjunction with the requirements of **5.2.2.1**, stiffeners are to be provided with end brackets as follows:

- brackets are to be fitted at the lower and upper ends when l_{stf-t} exceeds 4m
- brackets are to be fitted at the lower end when l_{stf-t} exceeds 2.5m.

Where:

l_{stf-t} : total length of stiffener as shown in **Fig. 8.5.1**, in *m*

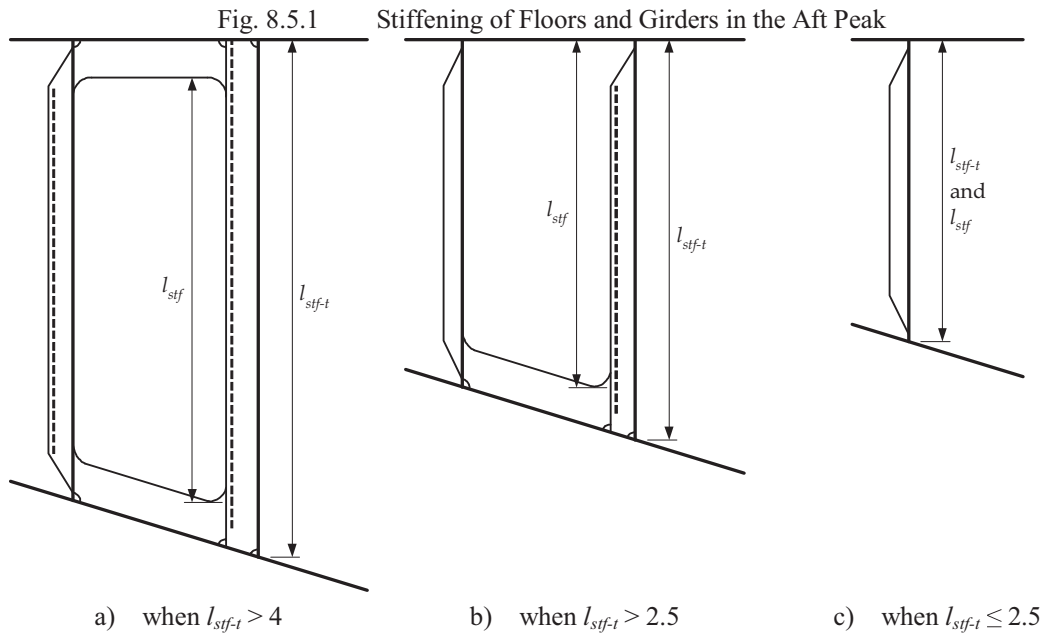

5.2.2.3 Heavy plate floors are to be fitted in way of the aft face of the horn and in line with the webs in the rudder horn. They may be required to be carried up to the first deck or flat. In this area, cut outs, scallops or other openings are to be kept to a minimum.

5.2.3 Stern frames

5.2.3.1 Stern frames may be fabricated from steel plates or made of cast steel. For applicable material specifications and steel grades see **Table 6.1.3**. Stern frames of other material or construction will be specially considered.

5.2.3.2 Scantlings below the propeller boss on stern frames for single screw vessels are to comply with the requirements in **5.2.3.3** or **5.2.3.4**, as applicable.

5.2.3.3 Fabricated stern frames are to satisfy the following criteria:

- (a) $t_{grs} \geq 2.25\sqrt{L_{CSR-T}}$ (mm)
- (b) $w_{stn} \geq 450$ (mm)
- (c) $t_{grs} \geq \frac{C_f L_{CSR-T}^{1.5}}{w_{stn}^2 \sqrt{1 + \left(\frac{2l_{stn}}{w_{stn}}\right)^2}}$ (mm)

Where:

- t_{grs} : gross thickness of side plating, in mm
- w_{stn} : width of stern frame, in mm, see **Fig. 8.5.2a**
- l_{stn} : length of stern frame, in mm, see **Fig. 8.5.2a**
- L_{CSR-T} : rule length, as defined in **Section 4/1.1.1.1**
- $C_f = 9600$

5.2.3.4 Cast stern frames are to satisfy the following criteria:

- (a) $t_{1-grs} \geq 3.0\sqrt{L_{CSR-T}}$ (mm), but not to be less than 25mm
- (b) $t_{2-grs} \geq 1.25t_{1-grs}$ (mm)
- (c) $\frac{(t_{1-grs} + t_{2-grs})}{2} \geq \frac{C_f L_{CSR-T}^{1.5}}{w_{stn}^2 \sqrt{1 + \left(\frac{2l_{stn}}{w_{stn}}\right)^2}}$ (mm)

Where:

- t_{1-grs} : gross thickness of casting at end, in mm, see **Fig. 8.5.2b**
- t_{2-grs} : gross thickness of casting at mid length, in mm, see **Fig. 8.5.2b**

w_{stn} : width of stern frame, in *mm*, see **Fig. 8.5.2b**

l_{stn} : length of stern frame, in *mm*, see **Fig. 8.5.2b**

L_{CSR-T} : rule length, as defined in **Section 4/1.1.1.1**

$C_f = 8400$

The thickness of butt welding to shell plating may be tapered below t_l with a length of taper that is at least three *times* the offset. The castings are to be cored out to avoid large masses of thick material likely to contain defects and are to maintain a relatively uniform section throughout.

Suitable radii are to be provided in way of changes in section.

5.2.3.5 Above the propeller boss, the scantlings are to be in accordance with **5.2.3.2** to **5.2.3.4** except that in the upper part of the propeller aperture, where the hull form is full and centreline supports are provided, the thickness may be reduced to 80% of the applicable requirements in **5.2.3.2** to **5.2.3.4**.

5.2.3.6 Where round bars are used at the aft edge of stern frames, their scantlings and connection details are to facilitate welding.

5.2.3.7 Ribs or horizontal brackets of thickness not less than $0.8t_{grs}$ or $0.8t_{l-grs}$ are to be provided at suitable intervals, where t_{grs} and t_{l-grs} are as defined in **5.2.3.3** and **5.2.3.4**. When t_{grs} or t_{l-grs} is reduced in accordance with **5.2.3.5**, a proportionate reduction in the thickness of ribs or horizontal brackets may be made.

5.2.3.8 Rudder gudgeons are to be an integral part of the stern frame and are to meet the requirements of the Society.

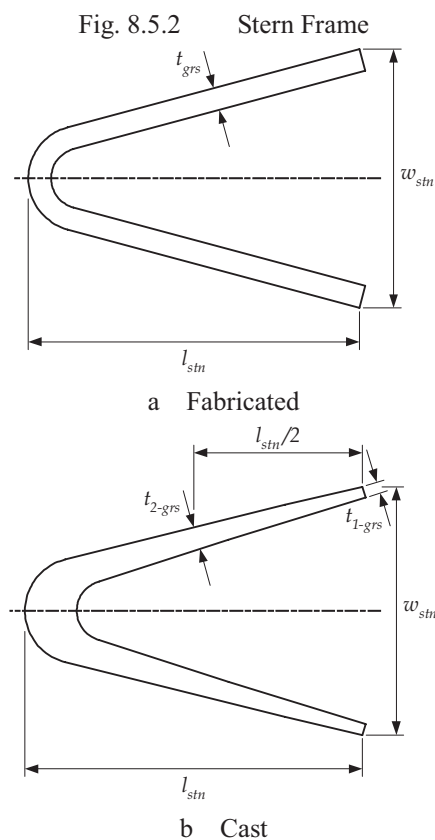

5.3 Shell Structure

5.3.1 Shell plating

5.3.1.1 The net thickness of the side shell and transom plating, t_{net} is to comply with the requirements in **3.9.2.1** and is not to be less than:

$$t_{net} = 0.035(L_2 - 42) + 0.009s \quad (mm)$$

Where:

L_2 : rule length, L_{CSR-T} , as defined in **Section 4/1.1.1.1**, but need not be taken greater than 300m

s : stiffener spacing, in mm , as defined in **Section 4/2.2**

5.3.1.2 The net plating thickness of shell, t_{net} , attached to the stern frame is to comply with the requirements in **3.9.2.1** and is not to be less than:

$$t_{net} = 0.094(L_2 - 43) + 0.009s \quad (mm)$$

Where:

L_2 : rule length, L_{CSR-T} , as defined in **Section 4/1.1.1.1**, but need not be taken greater than $300m$

s : stiffener spacing, in mm , as defined in **Section 4/2.2**

5.3.1.3 In way of the boss and heel plate, the shell net plating thickness, t_{net} , is not to be less than:

$$t_{net} = 0.105(L_2 - 47) + 0.011s \quad (mm)$$

Where:

L_2 : rule length, L_{CSR-T} , as defined in **Section 4/1.1.1.1**, but need not be taken greater than $300m$

s : stiffener spacing, in mm , as defined in **Section 4/2.2**

5.3.1.4 Within the extents specified in **2.2.4.3**, the thickness of the side shell plating is to comply with the requirements in **2.2.4.2**.

5.3.1.5 Heavy shell plates are to be fitted locally in way of the heavy plate floors as required by **5.2.2.3**. Outboard of the heavy floors, the heavy shell plates may be reduced in thickness in as gradual a manner as practicable. Where the horn plating is radiused into the shell plating, the radius at the shell connection, r , is not to be less than:

$$r = 150 + 0.8L_2 \quad (mm)$$

Where:

L_2 : rule length, L_{CSR-T} , as defined in **Section 4/1.1.1.1**, but need not be taken greater than $300m$

5.3.2 Shell local support members

5.3.2.1 The section modulus and thickness of the hull envelope framing are to comply with the requirements in **3.9.2.2** and **3.9.2.3**.

5.3.3 Shell primary support members

5.3.3.1 The requirements of **5.3.3** apply to single side skin construction supported by system of vertical webs and/or horizontal stringers or flats.

5.3.3.2 Where a longitudinal framing system is adopted, longitudinals are to be supported by vertical primary support members extending from the floors to the upper deck. Deck transverses are to be fitted in line with the web frames.

5.3.3.3 Where a transverse framing system is adopted, frames are to be supported by horizontal primary support members spanning between the vertical primary support members.

5.3.3.4 The scantlings of web frames supporting; longitudinal framing, stringers and transverse framing are to be determined from **3.9.3**.

5.3.3.5 The web depth of primary support members is not to be less than 14% of the bending span and is to be at least 2.5 *times* as deep as the slots for stiffeners if the slots are not closed.

5.4 Deck Structure

5.4.1 Deck plating

5.4.1.1 The thickness of the deck plating is to comply with the requirements in **3.9.2.1**.

5.4.1.2 (void)

5.4.2 Deck stiffeners

5.4.2.1 The section modulus and thickness of deck stiffeners are to comply with the requirements in **3.9.2.2** and **3.9.2.3**.

5.4.3 Deck primary support members

5.4.3.1 The section modulus and shear area of primary support members are to comply with the requirements in **3.9.3**.

5.4.3.2 The web depth of primary support members is not to be less than 10% and 7% of the unsupported span in bending in tanks and in dry spaces, respectively, and is not to be less than 2.5 times the depth of the slots if the slots are not closed. Unsupported span in bending is bending span as defined in **Section 4/2.1.4** or in case of a grillage structure the distance between connections to other primary support members.

5.4.3.3 In way of concentrated loads from heavy equipment, the scantlings of the deck structure are to be determined based on the actual loading. See also **Section 11/3**.

5.4.4 Pillars

5.4.4.1 Pillars are to be fitted in the same vertical line wherever possible and effective arrangements are to be made to distribute the load at the heads and heels of all pillars. Where pillars support eccentric loads, they are to be strengthened for the additional bending moment imposed upon them.

5.4.4.2 Tubular and hollow square pillars are to be attached at their heads and heels by efficient brackets, or doublers/insert plates, where applicable, to transmit the load effectively. Pillars are to be attached at their heads and heels by continuous welding. At the heads and heels of pillars built of rolled sections, the load is to be distributed by brackets or other equivalent means.

5.4.4.3 Pillars in tanks are to be of solid section. Where the hydrostatic pressure may result in tensile stresses in the pillar, the tensile stress in the pillar and its end connections is not to exceed 45% of the specified minimum yield stress of the material.

5.4.4.4 The scantlings of pillars are to comply with the requirements in **3.9.5**.

5.4.4.5 Where the loads from heavy equipment exceed the design load of **3.9.5**, the pillar scantlings are to be determined based on the actual loading.

5.5 Tank Bulkheads**5.5.1 General**

5.5.1.1 Tanks may be required to have divisions or deep wash structures to minimise the dynamic stress on the structure.

5.5.2 Construction

5.5.2.1 In no case are the scantlings of tank boundary bulkheads to be less than the requirements for watertight bulkheads.

5.5.3 Scantlings of tank boundary bulkheads

5.5.3.1 The thickness of tank boundary plating is to comply with the requirements in **3.9.2.1**.

5.5.3.2 The section modulus and thickness of stiffeners are to comply with the requirements in **3.9.2.2** and **3.9.2.3**.

5.5.3.3 The section modulus and shear area of primary support members are to comply with the requirements in **3.9.3**.

5.5.3.4 Web plating of primary support members is to have a depth of not less than 14% of the unsupported span in bending and not less than 2.5 times the depth of the slots if the slots are not closed.

5.6 Watertight Boundaries**5.6.1 General**

5.6.1.1 Watertight boundaries are to be fitted in accordance with **Section 5/2**.

5.6.1.2 The number of openings in watertight bulkheads is to be kept to a minimum compatible with the design and operation of the ship. Where penetrations of watertight bulkheads and internal decks are necessary for access, piping, ventilation, electrical cables, etc., arrangements are to be made to maintain the watertight integrity.

5.6.2 Aft peak bulkhead

5.6.2.1 An aft peak bulkhead complying with **Section 5/2.3** is to be provided.

5.6.2.2 The scantlings of structural components of the aft peak bulkhead are to comply with the requirements in 5.5 and 5.6.3, as applicable.

5.6.3 Scantlings of watertight boundaries

5.6.3.1 The thickness of boundary plating is to comply with the requirements in 3.9.2.1.

5.6.3.2 The section modulus and thickness of stiffeners are to comply with the requirements in 3.9.2.2 and 3.9.2.3.

5.6.3.3 The section modulus and shear area of primary support members are to comply with the requirements in 3.9.3.

5.6.3.4 Web plating of primary support members is to have a depth of not less than 10% of the unsupported span in bending and not less than 2.5 times the depth of the slots if the slots are not closed.

5.7 Miscellaneous Structures

5.7.1 Pillar bulkheads

5.7.1.1 Bulkheads that support girders, or pillars and longitudinal bulkheads which are fitted in lieu of girders, are to be stiffened to provide supports not less effective than required for stanchions or pillars. The acting load and the required net cross sectional area of the pillar section is to be determined using the requirements of 5.4.4. The net moment of inertia of the stiffener is to be calculated with a width of $40t_{net}$ of the plating, where t_{net} is net plating thickness in mm .

5.7.1.2 Pillar bulkheads are to meet the following requirements:

- (a) the distance between bulkhead stiffeners is not to exceed $1500mm$
- (b) where corrugated, the depth of the corrugation is not to be less than $100mm$.

5.7.2 Rudder trunk

5.7.2.1 The scantlings of the rudder trunk are to be in accordance with the shell plating and framing in 5.3.1 and 5.3.2. Where the rudder trunk is open to the sea, a seal or stuffing box is to be fitted above the deepest load waterline to prevent water from entering the steering gear compartment.

5.7.3 Stern thruster tunnels

5.7.3.1 The net thickness of the tunnel plating, $t_{tun-net}$ is not to be less than required for shell plating in the vicinity of the thruster. In addition $t_{tun-net}$ is not to be taken less than:

$$t_{tun-net} = 0.008d_{tun} + 1.8 \quad (mm)$$

Where:

d_{tun} : inside diameter of the tunnel, in mm , but not to be taken less than $970 mm$

5.7.3.2 Where the outboard ends of the tunnel are provided with bars or grids, the bars or grids are to be effectively secured.

6. Evaluation of Structure for Sloshing and Impact Loads

6.1 General

6.1.1 Application

6.1.1.1 The requirements of this Sub-Section cover the strengthening requirements for localised sloshing loads that may occur in tanks carrying liquid and local impact loads that may occur in the forward structure. The sloshing and impact loads to be applied in **6.2** to **6.4** are described in **Section 7/4**.

6.1.1.2 The net scantlings described in this Sub-Section are related to gross scantlings as follows:

- (a) for plating and local support members, the gross thickness and gross cross sectional properties are obtained from the applicable requirements by adding the full corrosion additions specified in **Section 6/3**
- (b) for primary support members, the gross sectional area, gross section modulus and other gross cross sectional properties are obtained from the applicable requirements by adding one half of the full corrosion additions specified in **Section 6/3**.

6.1.2 General scantling requirements

6.1.2.1 The requirements of **6.2** to **6.4** are to be applied in addition to the applicable requirements in **Section 8**.

6.1.2.2 Local scantling increases due to impact or sloshing loads are to be made with due consideration given to details and avoidance of hard spots, notches and other harmful stress concentrations.

6.2 Sloshing in Tanks

6.2.1 Scope and limitations

6.2.1.1 The requirements of **6.2** specify the scantling requirements for boundary and internal structure of tanks subject to sloshing loads, as given in **Section 7/4.2**, due to the free movement of liquid in tanks.

6.2.1.2 The structure of cargo tanks, slop tanks, ballast tanks and large deep tanks, e.g. fuel oil bunkering tanks and main fresh water tanks, are to be assessed for sloshing. Small tanks do not need to be assessed for sloshing pressures.

6.2.1.3 All cargo and ballast tanks are to have scantlings suitable for unrestricted filling heights.

6.2.1.4 The following structural members are to be assessed:

- (a) plates and stiffeners forming boundaries of tanks
- (b) plates and stiffeners on wash bulkheads
- (c) web plates and web stiffeners of primary support members located in tanks
- (d) tripping brackets supporting primary support members in tanks.

6.2.1.5 For tanks with effective sloshing breadth, b_{slh} , greater than $0.56B$ or effective sloshing length, l_{slh} , greater than $0.13L_{CSR-T}$, an additional sloshing impact assessment is to be carried out in accordance with the Society's procedures. The effective sloshing length, l_{slh} , and breadth, b_{slh} , are defined in **Section 7/4.2.2** and **Section 7/4.2.3** respectively.

6.2.2 Application of sloshing pressure

6.2.2.1 The following tanks are to be assessed for the design sloshing pressures $P_{slh-lng}$ and P_{slh-t} in accordance with **6.2.2.2** to **6.2.2.5**:

- (a) cargo and slop tanks
- (b) fore peak and aft peak ballast tanks
- (c) other tanks which allow free movement of liquid, except as follows:
 - where the effective sloshing length is less than $0.03L_{CSR-T}$, calculations involving $P_{slh-lng}$ are not required and where the effective sloshing breadth is less than $0.32B$, calculations involving P_{slh-t} are not required.

The design sloshing pressure for other tanks mentioned in **6.2.1.2** is to be taken as the minimum sloshing pressure, $P_{slh-min}$, as defined in **Section 7/4.2.4**.

6.2.2.2 The design sloshing pressure due to longitudinal liquid motion, $P_{slh-lng}$, as defined in **Section 7/4.2.2.1** is to be applied to the following members as shown in **Fig. 8.6.1**:

- (a) transverse tight bulkheads
- (b) transverse wash bulkheads

- (c) stringers on transverse tight and wash bulkheads
- (d) plating and stiffeners on the longitudinal bulkheads, deck and inner hull which are between the transverse bulkhead and the first web frame from the bulkhead or the bulkhead and $0.25l_{slh}$, whichever is lesser.

6.2.2.3 In addition to 6.2.2.2, the first web frame next to a transverse tight or wash bulkhead if the web frame is located within $0.25l_{slh}$ from the bulkhead, as shown in Fig. 8.6.1, is to be assessed for the web frame reflected sloshing pressure, P_{slh-wf} , as defined in Section 7/4.2.2.5.

6.2.2.4 The minimum sloshing pressure, $P_{slh-min}$, as defined in Section 7/4.2.4 is to be applied to all other members.

Fig. 8.6.1 Application of Sloshing Loads due to Longitudinal Liquid Motion

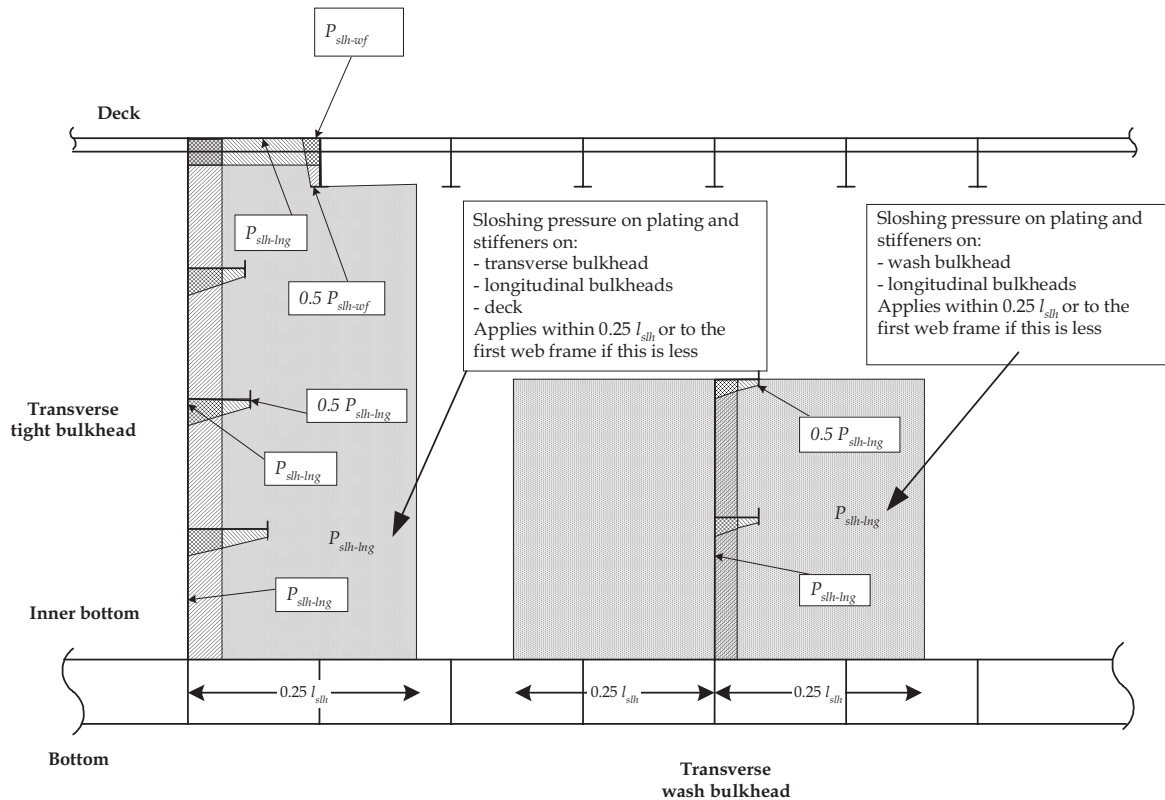

6.2.2.5 The design sloshing pressure due to transverse liquid motion, P_{slh-t} , as defined in Section 7/4.2.3.1, is to be applied to the following members as shown in Fig. 8.6.2:

- (a) longitudinal tight bulkhead
- (b) longitudinal wash bulkhead
- (c) horizontal stringers on longitudinal tight and wash bulkheads
- (d) plating and stiffeners on the transverse tight bulkheads including stringers and deck which are between the longitudinal bulkhead and the first girder from the bulkhead or the bulkhead and $0.25b_{slh}$ whichever is lesser.

6.2.2.6 In addition to 6.2.2.5, the first girder next to longitudinal tight or wash bulkhead if the girder is located within $0.25b_{slh}$ from the longitudinal bulkhead, as shown in Fig. 8.6.2, is to be assessed for the reflected sloshing pressure, $P_{slh-grd}$ as defined in Section 7/4.2.3.5.

Fig. 8.6.2 Application of Sloshing Loads due to Transverse Liquid Motion

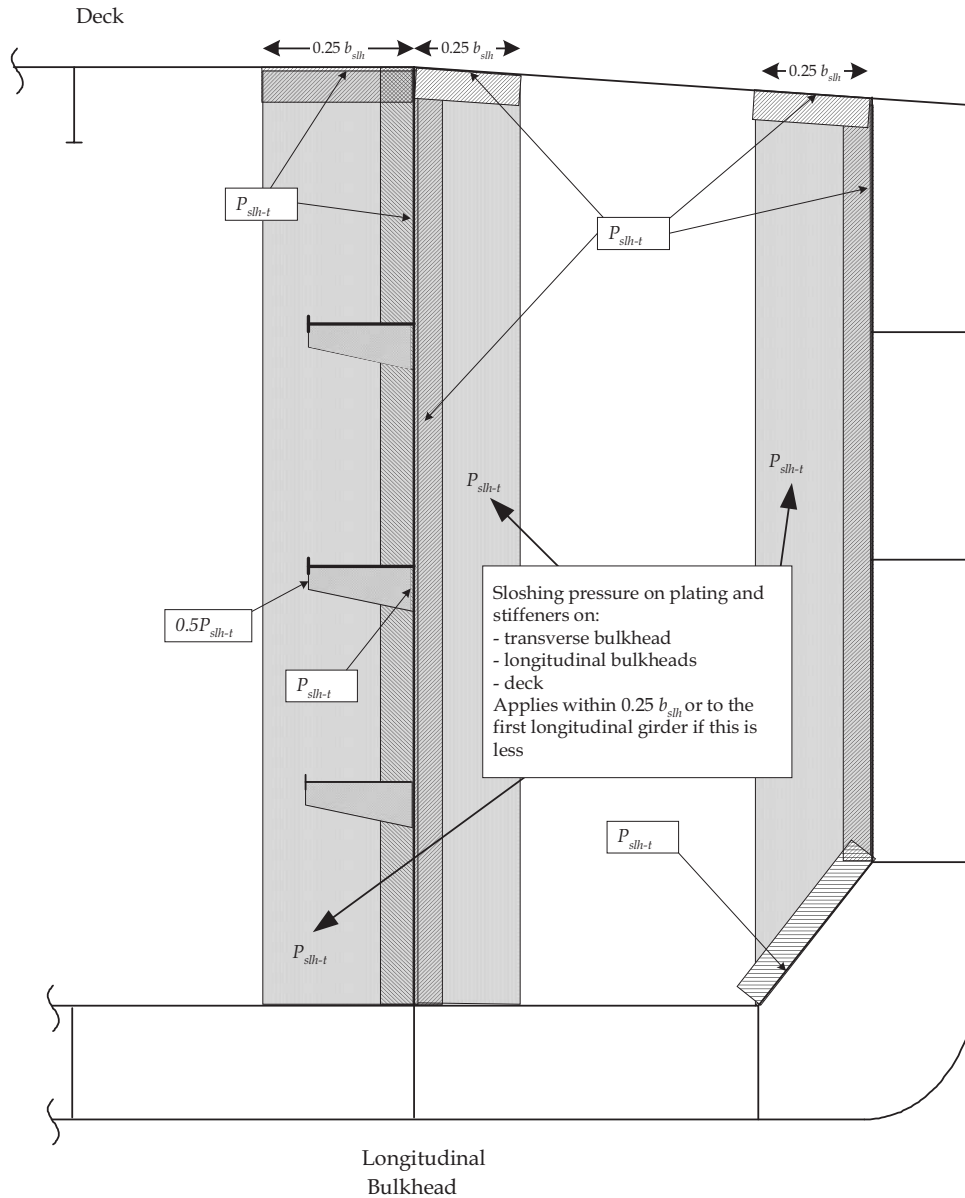

6.2.2.7 The minimum sloshing pressure, $P_{slh-min}$, as defined in **Section 7/4.2.4**, is to be applied to all other members.

6.2.2.8 The sloshing pressures due to transverse and longitudinal fluid motion are assumed to act independently. Structural members are therefore to be evaluated based on the greatest sloshing pressure due to longitudinal and transverse fluid motion.

6.2.3 Sloshing assessment of plating forming tank boundaries and wash bulkheads

6.2.3.1 The net thickness of plating forming tank boundaries and wash bulkheads, t_{net} , subjected to sloshing pressures is not to be less than:

$$t_{net} = 0.0158 \alpha_p s \sqrt{\frac{P_{slh}}{C_a \sigma_{yd}}} \quad (mm)$$

Where:

α_p : correction factor for the panel aspect ratio
 $= 1.2 - \frac{s}{2100 l_p}$ but not to be taken as greater than 1.0

s : stiffener spacing, in mm , as defined in **Section 4/2.2**

l_p : length of plate panel, to be taken as the spacing of primary support members, S , unless carlings are fitted, in m

- P_{slh} : the greater of $P_{slh-lng}$, P_{slh-t} or $P_{slh-min}$ as specified in **6.2.2**
- C_a : permissible plate bending stress coefficient as given in **Table 8.6.1**
- σ_{yd} : specified minimum yield stress of the material, in N/mm^2

6.2.4 Sloshing assessment of stiffeners on tank boundaries and wash bulkheads

6.2.4.1 The net section modulus, Z_{net} , of stiffeners on tank boundaries and wash bulkheads subjected to sloshing pressures is not to be less than:

$$Z_{net} = \frac{P_{slh} s l_{bdg}^2}{f_{bdg} C_s \sigma_{yd}} \quad (cm^3)$$

Where:

- l_{bdg} : effective bending span, of stiffener, as defined in **Section 4/2.1**, in m
- C_s : permissible bending stress coefficient as given in **Table 8.6.2**
- P_{slh} : the greater of $P_{slh-lng}$, P_{slh-t} or $P_{slh-min}$ as specified in **6.2.2**
- s : stiffener spacing, in mm , as defined in **Section 4/2.2**
- σ_{yd} : specified minimum yield stress of the material, in N/mm^2
- f_{bdg} : bending moment factor
 - = 12 for stiffeners fixed against rotation at each end. This is generally to be applied for scantlings of all continuous stiffeners
 - = 8 for stiffeners with one or both ends not fixed against rotation. This is generally to be applied to discontinuous stiffeners for other configurations the bending moment factor may be taken as given in **Table 8.3.5**

6.2.5 Sloshing assessment of primary support members

6.2.5.1 Web plating, web stiffeners and tripping brackets on stringers, girders and web frames in cargo and ballast tanks are to be assessed based on sloshing pressures as given in **6.2.2**.

6.2.5.2 The web plating net thickness of primary support members, t_{net} , is not to be less than:

$$t_{net} = 0.0158 \alpha_p s \sqrt{\frac{P_{slh}}{C_a \sigma_{yd}}} \quad (mm)$$

Where:

- α_p : correction factor for the panel aspect ratio
 - = $1.2 - \frac{s}{2100 l_p}$ but not to be taken as greater than 1.0
- s : stiffener spacing, in mm , as defined in **Section 4/2.2**
- l_p : length of plate panel, mean spacing between local support members on the long edges of the panel, typically between tripping brackets, in m
- P_{slh} : the greater of $P_{slh-lng}$, P_{slh-t} , P_{slh-wf} , $P_{slh-grd}$ or $P_{slh-min}$ as specified in **6.2.2**. The pressure is to be calculated at the load application point, defined in **Section 3/5.1.2**, taking into account the distribution over the height of the member, as shown in **Fig. 8.6.1**
- C_a : permissible plate bending stress coefficient as given in **Table 8.6.1**
- σ_{yd} : specified minimum yield stress of the material, in N/mm^2

6.2.5.3 The net section modulus, Z_{net} , of each individual stiffener on the web plating of primary support members subjected to sloshing pressures is not to be less than:

$$Z_{net} = \frac{P_{slh} s l_{bdg}^2}{f_{bdg} C_s \sigma_{yd}} \quad (cm^3)$$

Where:

- P_{slh} : the greater of $P_{slh-lng}$, P_{slh-t} , P_{slh-wf} , $P_{slh-grd}$ or $P_{slh-min}$ as specified in **6.2.2**. The pressure is to be calculated at the load application point taking into account the distribution over the height of the member, as shown in **Fig. 8.6.1** and **8.6.2**.

- s : stiffener spacing, in mm , as defined in **Section 4/2.2**
 l_{bdg} : effective bending span, in m , of web stiffener as defined in **Section 4/2.1**
 C_s : permissible bending stress coefficient as given in **Table 8.6.2**
 f_{bdg} : bending moment factor
 = 12 for stiffeners fixed against rotation at each end.
 This is generally to be applied for scantlings of all continuous stiffeners
 = 8 for stiffeners with one or both ends not fixed against rotation.
 This is generally to be applied to discontinuous stiffeners for other configurations the bending moment factor may be taken as given in

Table 8.3.5

- σ_{yd} : specified minimum yield stress of the material, in N/mm^2

6.2.5.4 The net section modulus, Z_{net} , in way of the base of tripping brackets supporting primary support members in cargo and ballast tanks is not to be less than:

$$Z_{net} = \frac{1000 P_{slh} s_{trip} l_{trip}^2}{2 C_s \sigma_{yd}} \quad (cm^3)$$

Where:

- P_{slh} : the greater of $P_{slh-lng}$, P_{slh-t} , P_{slh-wf} , $P_{slh-grd}$ and $P_{slh-min}$ as defined in **6.2.2**. The average pressure may be calculated at mid point of the tripping bracket taking into account the distribution as shown in **Fig. 8.6.1** and **8.6.2**
 s_{trip} : mean spacing, between tripping brackets or other primary support members or bulkheads, in m
 l_{trip} : length of tripping bracket, see **Fig. 8.6.3**, in m
 C_s : permissible bending stress coefficient for tripping brackets
 = 0.75
 σ_{yd} : specified minimum yield stress of the material, in N/mm^2

6.2.5.4bis The effective breadth of the attached plate to be used for calculating the section modulus of the tripping bracket supporting primary support members is to be taken as 1/3 the length of the tripping bracket, l_{trip} , as given in **8/6.2.5.4**.

6.2.5.5 The net shear area, $A_{shr-net}$, after deduction of cut-outs and slots, of tripping brackets supporting primary support members in cargo and ballast tanks is not to be less than:

$$A_{shr-net} = 10 \frac{P_{slh} s_{trip} l_{trip}}{C_t \tau_{yd}} \quad (cm^2)$$

Where:

- P_{slh} : the greater of $P_{slh-lng}$, P_{slh-t} , P_{slh-wf} , $P_{slh-grd}$ and $P_{slh-min}$ as defined in **6.2.2**.
 The average pressure may be calculated at mid point of the tripping bracket taking into account the distribution as shown in **Fig. 8.6.1** and **8.6.2**
 s_{trip} : mean spacing, between tripping brackets or other primary support members or bulkheads, in m
 l_{trip} : length of tripping bracket, see **Fig. 8.6.3**, in m
 C_t : permissible shear stress coefficient, as given in **Table 8.6.3**
 $\tau_{yd} = \frac{\sigma_{yd}}{\sqrt{3}} \quad (N/mm^2)$
 σ_{yd} : specified minimum yield stress of the material, in N/mm^2

Fig.8.6.3 Effective Length of Tripping Bracket

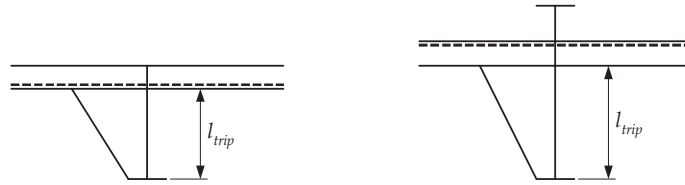

Table 8.6.1 Allowable Plate Bending Stress Coefficient, C_a , for Assessment of Sloshing on Plates

The permissible bending stress coefficient for the design load set being considered is to be taken as:

$$C_a = \beta_a - \alpha_a \frac{|\sigma_{hg}|}{\sigma_{yd}} \quad \text{but not to be taken greater than } C_{a-max}$$

Where:

$\alpha_a, \beta_a, C_{a-max}$ permissible bending stress factors and are to be taken as follows

Acceptance Criteria Set	Structural Member	β_a	α_a	C_{a-max}	
AC1	Longitudinal strength members in the cargo tank region including but not limited to: deck longitudinal plane bulkhead horizontal corrugated longitudinal bulkhead longitudinal girders and stringers within the cargo tank region	Longitudinally stiffened plating	0.9	0.5	0.8
		Transversely or vertically stiffened plating	0.9	1.0	0.8
	Other strength members including: vertical corrugated longitudinal bulkhead transverse plane bulkhead transverse corrugated bulkhead transverse stringers and web frames plating of tank boundaries and primary support members outside the cargo tank region		0.8	0	0.8

σ_{hg} : hull girder bending stress for the design load set being considered and calculated at the load calculation point defined in **Section 3/5.1.2**

$$= \left(\frac{(z - z_{NA-net50}) M_{sw-perm-sea}}{I_{v-net50}} \right) 10^{-3} \quad (N/mm^2)$$

z : vertical coordinate of the load calculation point under consideration, in m

$z_{NA-net50}$: distance from the baseline to the horizontal neutral axis, as defined in **Section 4/2.6.1**, in m

$M_{sw-perm-sea}$: permissible hull girder hogging and sagging still water bending moment for seagoing operation at the location being considered, in kNm . The greatest of the sagging and hogging bending moment is to be used, see **Section 7/2.1**.

$I_{v-net50}$: net vertical hull girder moment of inertia, at the longitudinal position being considered, as defined in **Section 4/2.6.1**, in m^4

σ_{yd} : specified minimum yield stress of the material, in N/mm^2

Table 8.6.2 Allowable Bending Stress Coefficient, C_s , for Assessment of Sloshing on Stiffeners

The permissible bending stress coefficient for the design load set being considered is to be taken as:

$$C_s = \beta_s - \alpha_s \frac{|\sigma_{hg}|}{\sigma_{yd}} \quad \text{but not to be taken greater than } C_{s-max}$$

Where:

$\alpha_s, \beta_s, C_{s-max}$: permissible bending stress factors and are to be taken as follows

Acceptance Criteria Set	Structural Member	β_s	α_s	C_{s-max}	
AC1	Longitudinal strength members in the cargo tank region including but not limited to: deck stiffeners	Longitudinal stiffeners	0.85	1.0	0.75
	stiffeners on longitudinal bulkheads stiffeners on longitudinal girders and stringers within the cargo tank region				
	Other strength members including: stiffeners on transverse bulkheads stiffeners on transverse stringers and web frames stiffeners on tank boundaries and primary support members outside the cargo tank region		0.75	0	0.75

σ_{hg} : hull girder bending stress for the design load set being considered at the reference point defined in **Section 3/5.2.2.5**

$$= \left(\frac{(z - z_{NA-net50}) M_{sw-perm-sea}}{I_{v-net50}} \right) 10^{-3} \quad (N/mm^2)$$

z : vertical coordinate of the reference point defined in **Section 3/5.2.2.5**, in m

$z_{NA-net50}$: distance from the baseline to the horizontal neutral axis, as defined in **Section 4/2.6.1**, in m

$M_{sw-perm-sea}$: permissible hull girder hogging and sagging still water bending moment for seagoing operation at the location being considered, in kNm .

Stiffener Location	$M_{sw-perm-sea}$	
	Pressure acting on Plate Side	Pressure acting on Stiffener Side
Above Neutral Axis	Sagging SWBM	Hogging SWBM
Below Neutral Axis	Hogging SWBM	Sagging SWBM

$I_{v-net50}$: net vertical hull girder moment of inertia, at the longitudinal position being considered, as defined in **Section 4/2.6.1**, in m^4

σ_{yd} : specified minimum yield stress of the material, in N/mm^2

Table 8.6.3 Permissible Shear Stress Coefficient

Acceptance Criteria Set	Structural member	C_t
AC1	Tripping brackets	0.75

6.3 Bottom Slamming

6.3.1 Application

6.3.1.1 Where the minimum draughts forward, T_{FP-mt} or $T_{FP-full}$, as specified in **Section 7/4.3.2.1**, is less than $0.045L_{CSR-T}$, the bottom forward is to be additionally strengthened to resist bottom slamming pressures.

6.3.1.2 The draughts for which the bottom has been strengthened are to be indicated on the shell expansion plan and loading guidance information, see **1.1**.

6.3.1.3 The scantlings described in 6.3 are net scantlings, which are related to gross scantlings as described in 6.1.1.2. The section modulus and shear area of the primary support members is to be determined as specified in Section 4/2.5.

6.3.1.4 The section modulus and web thickness of the local support members apply to the areas clear of the end brackets. The cross sectional shear areas of primary support members are to be applied as required by 6.3.7.3 and 6.3.7.4.

6.3.2 Extent of strengthening

6.3.2.1 The strengthening is to extend forward of $0.3L_{CSR-T}$ from the F.P. over the flat of bottom and adjacent plating with attached stiffeners up to a height of 500mm above the baseline, see Fig. 8.6.4.

Fig. 8.6.4 Extent of strengthening against bottom slamming

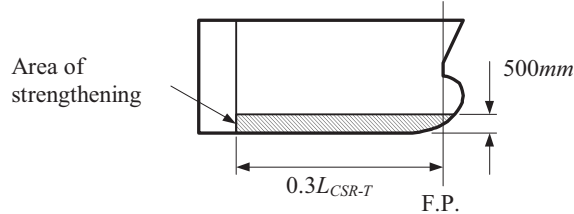

6.3.2.2 Outside the region strengthened to resist bottom slamming the scantlings are to be tapered to maintain continuity of longitudinal and/or transverse strength.

6.3.3 Design to resist bottom slamming loads

6.3.3.1 The design of end connections of stiffeners in the bottom slamming region is to ensure end fixity, either by making the stiffeners continuous through supports or by providing end brackets complying with Section 4/3.2.3.

Where it is not practical to comply with this requirement the net plastic section modulus, $Z_{pl-alt-net}$, for alternative end fixity arrangements is not to be less than:

$$Z_{pl-alt-net} = \frac{16Z_{pl-net}}{f_{bdg}} \quad (cm^3)$$

Where:

Z_{pl-net} : net plastic section modulus, in cm^3 , as required by 6.3.5.1

f_{bdg} : bending moment factor

$$= 8 \left(1 + \frac{n_s}{2} \right)$$

n_s = 0 for both ends with low end fixity (simply supported)

= 1 for one end equivalent to built in and one end simply supported

6.3.3.2 Scantlings and arrangements at primary support members, including bulkheads, are to comply with 6.3.7.

6.3.4 Hull envelope plating

6.3.4.1 The net thickness of the hull envelope plating, t_{net} , is not to be less than:

$$t_{net} = \frac{0.0158 \alpha_p s}{C_d} \sqrt{\frac{P_{slm}}{C_a \sigma_{yd}}} \quad (mm)$$

Where:

α_p : correction factor for the panel aspect ratio

$$= 1.2 - \frac{s}{2100l_p} \quad \text{but not to be taken as greater than 1.0}$$

s : stiffener spacing, in mm , as defined in Section 4/2.2

l_p : length of plate panel, to be taken as the spacing between primary support members (see Section 4/2.2.2) or panel breakers, in m

P_{slm} : bottom slamming pressure as given in Section 7/4.3 and calculated at the load calculation point defined in Section 3/5.1.2, in kN/m^2

C_d : plate capacity correction coefficient

$$= 1.3$$

C_a : permissible bending stress coefficient

$$= 1.0 \text{ for acceptance criteria set AC3}$$

σ_{yd} : specified minimum yield stress of the material, in N/mm^2

6.3.5 Hull envelope stiffeners

6.3.5.1 The net plastic section modulus, Z_{pl-net} , of each individual stiffener, is not to be less than:

$$Z_{pl-net} = \frac{P_{slm} s l_{bdg}^2}{f_{bdg} C_s \sigma_{yd}} \quad (cm^3)$$

Where:

P_{slm} : bottom slamming pressure as given in **Section 7/4.3** and calculated at the load calculation point defined in **Section 3/5.2.2**, in kN/m^2

s : stiffener spacing, in mm , as defined in **Section 4/2.2**

l_{bdg} : effective bending span, as defined in **Section 4/2.1.1**, in m

f_{bdg} : bending moment factor

$$= 8 \left(1 + \frac{n_s}{2} \right)$$

n_s = 2.0 for continuous stiffeners or where stiffeners are bracketed at both ends see **6.3.3.1** for alternative arrangements

C_s : permissible bending stress coefficient

$$= 0.9 \text{ for acceptance criteria set AC3}$$

σ_{yd} : specified minimum yield stress of the material, in N/mm^2

6.3.5.2 The net web thickness, t_{w-net} , of each longitudinal is not to be less than:

$$t_{w-net} = \frac{P_{slm} s l_{shr}}{2d_{shr} C_t \tau_{yd}} \quad (mm)$$

Where:

l_{shr} : effective shear span, as defined in **Section 4/2.1.2**, in m

s : stiffener spacing, in mm , as defined in **Section 4/2.2**

P_{slm} : bottom slamming pressure as given in **Section 7/4.3** and calculated at the load calculation point defined in **Section 3/5.2.2**, in kN/m^2

d_{shr} : effective web depth of stiffener, in mm , as defined in **Section 4/2.4.2.2**

C_t : permissible shear stress coefficient

$$= 1.0 \text{ for acceptance criteria set AC3}$$

$$\tau_{yd} = \frac{\sigma_{yd}}{\sqrt{3}} \quad (N/mm^2)$$

σ_{yd} : specified minimum yield stress of the material, in N/mm^2

6.3.5.3 The slenderness ratio of each longitudinal is to comply with **Section 10/2**.

6.3.6 Definition of idealised bottom slamming load area for primary support members

6.3.6.1 The scantlings of items in **6.3.7** are based on the application of the slamming pressure defined in **Section 7/4.3** to an idealised area of hull envelope plating, the slamming load area, A_{slm} , given by:

$$A_{slm} = \frac{1.1 L_{CSR-T} B C_b}{1000} \quad (m^2)$$

Where:

L_{CSR-T} : rule length, as defined in **Section 4/1.1.1.1**

B : moulded breadth, in m , as defined in **Section 4/1.1.3.1**

C_b : block coefficient, as defined in **Section 4/1.1.9.1**

6.3.7 Primary support members

6.3.7.1 The size and number of openings in web plating of the floors and girders is to be minimised considering the required shear area as given in **6.3.7.2**.

6.3.7.2 The net shear area, $A_{shr-net50}$, of each primary support member web at any position along its span is not to be less than:

$$A_{shr-net50} = 10 \frac{Q_{slm}}{C_t \tau_{yd}} \quad (cm^2)$$

Where:

Q_{slm} : the greatest shear force due to slamming for the position being considered, in kN , based on the application of a patch load, F_{slm} to the most onerous location, as determined in accordance with **6.3.7.3**

C_t : permissible shear stress coefficient
= 0.9 for acceptance criteria set AC3

$$\tau_{yd} = \frac{\sigma_{yd}}{\sqrt{3}} \quad (N/mm^2)$$

σ_{yd} : specified minimum yield stress of the material, in N/mm^2

6.3.7.3 For simple arrangements of primary support members, where the grillage affect may be ignored, the shear force, Q_{slm} , is given by:

$$Q_{slm} = f_{pt} f_{dist} F_{slm} \quad (kN)$$

Where:

f_{pt} : Correction factor for the proportion of patch load acting on a single primary support member
= $0.5(f_{slm}^3 - 2f_{slm}^2 + 2)$

f_{slm} : patch load modification factor
= $0.5 \frac{b_{slm}}{S}$, but not to be greater than 1.0

f_{dist} : factor for the greatest shear force distribution along the span, see **Fig. 8.6.5**

$$F_{slm} = P_{slm} l_{slm} b_{slm}$$

P_{slm} : bottom slamming pressure as given in **Section 7/4.3** and calculated at the load calculation point defined in **Section 3/5.3.2**, in kN/m^2

l_{slm} : extent of slamming load area along the span
= $\sqrt{A_{slm}}$ m , but not to be greater than l_{shr}

l_{shr} : effective shear span, as defined in **Section 4/2.1.5**, in m

b_{slm} : breadth of impact area supported by primary support member
= $\sqrt{A_{slm}}$ m , but not to be greater than S

A_{slm} : as defined in **6.3.6.1**

S : primary support member spacing, in m , as defined in **Section 4/2.2.2**

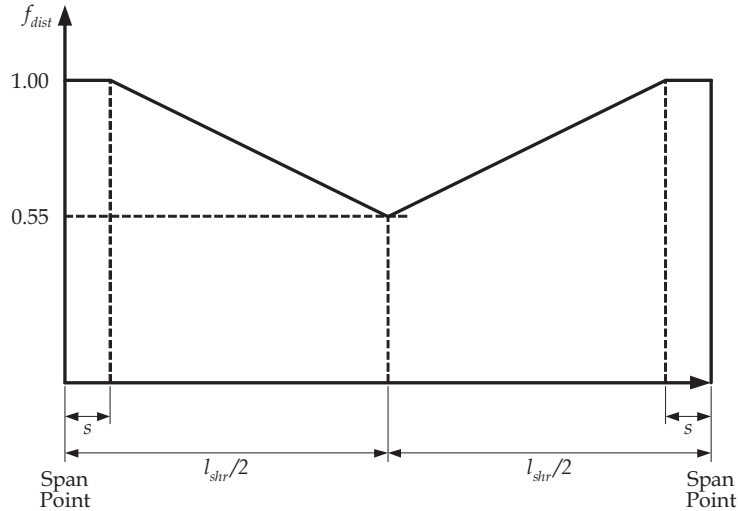
Fig. 8.6.5 Distribution of f_{dist} along the Span of Simple Primary Support Members

Where:

s : stiffener spacing

l_{shr} : effective shear span, in m , as defined in **Section 4/2.1.5**

6.3.7.4 For complex arrangements of primary support members, the greatest shear force, Q_{slm} , at any location along the span of each primary support member is to be derived by direct calculation in accordance with **Table 8.6.4**.

 Table 8.6.4 Direct Calculation Methods for Derivation of Q_{slm}

Type of analysis	Beam theory	Double bottom grillage
Model extent	Overall span of member between effective bending supports	Longitudinal extent to be one cargo tank length Transverse extent to be between inner hopper knuckle and centreline
Assumed end fixity of floors	Fixed at ends	Floors and girders to be fixed at boundaries of the model

Note

1. The envelope of greatest shear force along each primary support member is to be derived by applying the load patch to a number of locations along the span, see **6.3.7.2**.

6.3.7.5 The net web thickness, t_{w-net} , of primary support members adjacent to the shell is not to be less than:

$$t_{w-net} = \frac{s_w}{70} \sqrt{\frac{\sigma_{yd}}{235}} \quad (mm)$$

Where:

s_w : plate breadth, in mm , taken as the spacing between the web stiffening

σ_{yd} : specified minimum yield stress of the material, in N/mm^2

6.3.8 Connection of longitudinals to primary support members

6.3.8.1 Longitudinals are, in general, to be continuous. Where this not practicable end brackets complying with **4/3.2.3** are to be provided.

6.3.8.2 The scantlings in way of the end connections of each longitudinal are to comply with the requirements of **Section 4/3.4**.

6.4 Bow Impact

6.4.1 Application

6.4.1.1 The side structure in the area forward of $0.1L_{CSR-T}$ from the F.P. is to be strengthened against bow impact pressures.

6.4.1.2 The scantlings described in 6.4 are net scantlings, which are related to gross scantlings as described in 6.1.1.2.

6.4.1.3 The section modulus and web thickness of the local support members apply to the areas clear of the end brackets. The section modulus of the primary support member is to apply along the bending span clear of end brackets and cross sectional areas of the primary support member is to be applied at the ends/supports and may be gradually reduced along the span and clear of the ends/supports following the distribution of f_{dist} indicated in Fig. 8.6.5.

6.4.2 Extent of strengthening

6.4.2.1 The strengthening is to extend forward of $0.1L_{CSR-T}$ from the F.P. and vertically above the minimum design ballast draught, T_{bal} , defined in Section 4/1.1.5.2. See Fig. 8.6.6.

Fig. 8.6.6 Extent of Strengthening Against Bow Impact

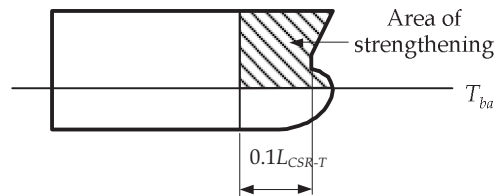

6.4.2.2 Outside the strengthening region as given in 6.4.2.1 the scantlings are to be tapered to maintain continuity of longitudinal and/or transverse strength.

6.4.3 Design to resist bow impact loads

6.4.3.1 In the bow impact region, longitudinal framing is to be carried as far forward as practicable.

6.4.3.2 The design of end connections of stiffeners in the bow impact region are to ensure end fixity, either by making the stiffeners continuous through supports or by providing end brackets complying with Section 4/3.2.3.

Where it is not practical to comply with this requirement the net plastic section modulus, $Z_{pl-alt-net}$, for alternative end fixity arrangements is not to be less than:

$$Z_{pl-alt-net} = \frac{16Z_{pl-net}}{f_{bdg}} \quad (cm^3)$$

Where:

Z_{pl-net} : effective net plastic section modulus, required by 6.4.5, in cm^3

f_{bdg} : bending moment factor

$$= 8 \left(1 + \frac{n_s}{2} \right)$$

n_s = 0 for both ends with low end fixity (simply supported)

= 1.0 for one end equivalent to built in and one end simply supported

6.4.3.3 Scantlings and arrangements at primary support members, including decks and bulkheads, are to comply with 6.4.7. In areas of greatest bow impact load the adoption of web stiffeners arranged perpendicular to the hull envelope plating and the provision of double sided lug connections are, in general to be applied.

6.4.3.4 The main stiffening direction of decks and bulkheads supporting shell framing is to be arranged parallel to the span direction of the supported shell frames, to protect against buckling.

6.4.4 Side shell plating

6.4.4.1 The net thickness of the side shell plating, t_{net} , is not to be less than:

$$t_{net} = 0.0158 \alpha_p s \sqrt{\frac{P_{im}}{C_a \sigma_{yd}}} \quad (mm)$$

Where:

- α_p : correction factor for the panel aspect ratio
 $= 1.2 - \frac{s}{2100 l_p}$ but is not to be taken as greater than 1.0
- s : stiffener spacing, in *mm*, as defined in **Section 4/2.2**
- l_p : length of plate panel, to be taken as the spacing between the primary support members, see **Section 4/2.2.2**, or panel breakers, in *m*
- P_{im} : bow impact pressure as given in **Section 7/4.4** and calculated at the load calculation point defined in **Section 3/5.1.2**, in *kN/m²*
- C_a : permissible bending stress coefficient
 $= 1.0$ for acceptance criteria set AC3
- σ_{yd} : specified minimum yield stress of the material, in *N/mm²*

6.4.5 Side shell stiffeners

6.4.5.1 The effective net plastic section modulus, Z_{pl-net} , of each stiffener, in association with the effective plating to which it is attached, is not to be less than:

$$Z_{pl-net} = \frac{P_{im} s l_{bdg}^2}{f_{bdg} C_s \sigma_{yd}} \quad (cm^3)$$

Where:

- P_{im} : bow impact pressure as given in **Section 7/4.4** and calculated at the load calculation point defined in **Section 3/5.2.2**, in *kN/m²*
- s : stiffener spacing, in *mm*, as defined in **Section 4/2.2**
- l_{bdg} : effective bending span, as defined in **Section 4/2.1.1**, in *m*
- f_{bdg} : bending moment factor
 $= 8 \left(1 + \frac{n_s}{2} \right)$
- n_s : $= 2.0$ for continuous stiffeners or where stiffeners are bracketed at both ends
see **6.4.3.2** for alternative arrangements
- C_s : permissible bending stress coefficient
 $= 0.9$ for acceptance criteria set AC3
- σ_{yd} : specified minimum yield stress of the material, in *N/mm²*

6.4.5.2 The net web thickness, t_{w-net} , of each stiffener is not to be less than:

$$t_{w-net} = \frac{P_{im} s l_{shr}}{2 d_{shr} C_t \tau_{yd}} \quad (mm)$$

Where:

- l_{shr} : effective shear span, as defined in **Section 4/2.1.2**, in *m*
- s : stiffener spacing, in *mm*, as defined in **Section 4/2.2**
- P_{im} : bow impact pressure as given in **Section 7/4.4** and calculated at the load calculation point defined in **Section 3/5.2.2**, in *kN/m²*
- d_{shr} : effective web depth of stiffener, in *mm*, as defined in **Section 4/2.4.2.2**
- C_t : permissible shear stress coefficient
 $= 1.0$ for acceptance criteria set AC3
- $\tau_{yd} = \frac{\sigma_{yd}}{\sqrt{3}} \quad (N/mm^2)$
- σ_{yd} : specified minimum yield stress of the material, in *N/mm²*

6.4.5.3 The slenderness ratio of each longitudinal is to comply with **Section 10/2**.

6.4.5.4 The minimum net thickness of breasthooks/diaphragm plates, t_{w-net} , is not to be less than:

$$t_{w-net} = \frac{s}{70} \sqrt{\frac{\sigma_{yd}}{235}} \quad (mm)$$

Where:

- s : spacing of stiffeners on the web, as defined in **Section 4/2.2**, in mm .
Where no stiffeners are fitted s is to be taken as the depth of the web
- σ_{yd} : specified minimum yield stress of the material, in N/mm^2

6.4.6 Definition of idealised bow impact load area for primary support members

6.4.6.1 The scantlings of items in **6.4.7** are based on the application of the bow impact pressure, as defined in **Section 7/4.4**, to an idealised area of hull envelope plating, where the bow impact load area, A_{slm} , is given by:

$$A_{slm} = \frac{1.1L_{CSR-T}BC_b}{1000} \quad (m^2)$$

Where:

- L_{CSR-T} : rule length, as defined in **Section 4/1.1.1.1**
- B : moulded breadth, in m , as defined in **Section 4/1.1.3.1**
- C_b : block coefficient, as defined in **Section 4/1.1.9.1**

6.4.7 Primary support members

6.4.7.1 Primary support members in the bow impact region are to be configured to ensure effective continuity of strength and the avoidance of hard spots.

6.4.7.2 To limit the deflections under extreme bow impact loads and ensure boundary constraint for plate panels, the spacing, S , measured along the shell girth of web frames supporting longitudinal framing or stringers supporting transverse framing is not to be greater than:

$$S = 3 + 0.008L_2 \quad (m)$$

Where:

- L_2 : rule length, L_{CSR-T} , as defined in **Section 4/1.1.1.1**, but not to be taken greater than $300m$

6.4.7.3 End brackets of primary support members are to be suitably stiffened along their edge. Consideration is to be given to the design of bracket toes to minimise abrupt changes of cross-section.

6.4.7.4 Tripping arrangements are to comply with **Section 10/2.3.3**. In addition, tripping brackets are to be fitted at the toes of end brackets and at locations where the primary support member flange is knuckled or curved.

6.4.7.5 The net section modulus of each primary support member, Z_{net50} , is not to be less than:

$$Z_{net50} = 1000 \frac{f_{bdg-pt} P_{im} b_{slm} f_{slm} l_{bdg}^2}{f_{bdg} C_s \sigma_{yd}} \quad (cm^3)$$

Where:

- f_{bdg-pt} : correction factor for the bending moment at the ends and considering the patch load
 $= 3f_{slm}^3 - 8f_{slm}^2 + 6f_{slm}$
- f_{slm} : patch load modification factor
 $= \frac{l_{slm}}{l_{bdg}}$
- l_{slm} : extent of bow impact load area along the span
 $= \sqrt{A_{slm}} \quad (m)$, but not to be taken as greater than l_{bdg}
- A_{slm} : bow impact load area, in m^2 , as defined in **6.4.6.1**
- l_{bdg} : effective bending span, as defined in **Section 4/2.1.4**, in m
- P_{im} : bow impact pressure as given in **Section 7/4.4** and calculated at the load calculation point defined in **Section 3/5.3.1**, in kN/m^2
- b_{slm} : breadth of impact load area supported by the primary support member, to be taken as the spacing between primary support members as defined

- in **Section 4/2.2.2**, but not to be taken as greater than l_{slm} , in m
- f_{bdg} : bending moment factor
 = 12 for primary support members with end fixed continuous face plates, stiffeners or where stiffeners are bracketed in accordance with **Section 4/3.3** at both ends
- C_s : permissible bending stress coefficient
 = 0.8
- σ_{yd} : specified minimum yield stress of the material, in N/mm^2

6.4.7.6 The net shear area of the web, $A_{shr-net50}$, of each primary support member at the support/toe of end brackets is not to be less than:

$$A_{shr-net50} = \frac{5f_{pt} P_{im} b_{slm} l_{shr}}{C_t \tau_{yd}} \quad (cm^2)$$

Where:

- f_{pt} : patch load modification factor
 = $\frac{l_{slm}}{l_{shr}}$
- l_{slm} : extent of bow impact load area along the span
 = $\sqrt{A_{slm}}$ (m), but not to be taken as greater than l_{shr}
- l_{shr} : effective shear span, as defined in **Section 4/2.1.5**, in m
- P_{im} : bow impact pressure as given in **Section 7/4.4** and calculated at the load calculation point defined in **Section 3/5.3.2**, in kN/m^2
- b_{slm} : breadth of impact load area supported by the primary support member, to be taken as the spacing between primary support members as defined in **Section 4/2.2.2**, but not to be taken as greater than l_{slm} , in m
- C_t : permissible shear stress coefficient
 = 0.75 for acceptance criteria set AC3
- τ_{yd} = $\frac{\sigma_{yd}}{\sqrt{3}}$ (N/mm^2)
- σ_{yd} : specified minimum yield stress of the material, in N/mm^2

6.4.7.7 The net web thickness of each primary support member, t_{w-net} , including decks/bulkheads in way of the side shell is not to be less than:

$$t_{w-net} = \frac{P_{im} b_{slm}}{\sin \phi_w \sigma_{crb}} \quad (mm)$$

Where:

- P_{im} : bow impact pressure as given in **Section 7/4.4** and calculated at the load calculation point defined in **Section 3/5.3.2** or at the intersection of the side shell with the deck/bulkhead, in kN/m^2
- b_{slm} : breadth of impact load area supported by the primary support member, to be taken as spacing between primary support members as defined in **Section 4/2.2.2**, but not to be taken as greater than l_{slm} , in m
- ϕ_w : angle, in *degrees*, between the primary support member web and the shell plate, see **Fig. 8.6.7**
- σ_{crb} : critical buckling stress in compression of the web of the primary support member or deck/bulkhead panel in way of the applied load given by **Section 10/3.2.1**, in N/mm^2

Fig. 8.6.7 Angle between Shell Primary Member and Shell Plate

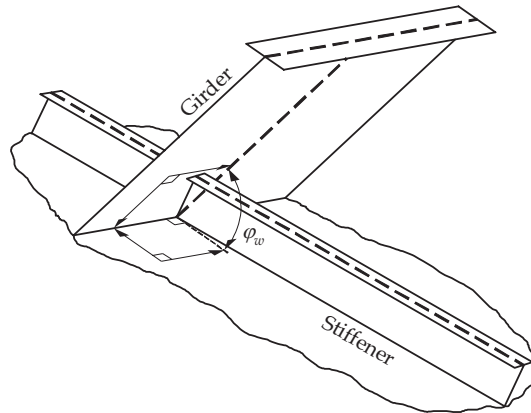

6.4.8 Connection of stiffeners to primary support members

6.4.8.1 Stiffeners are, in general, to be continuous. Where this not practicable end brackets complying with **Section 4/3.2.3** are to be provided.

6.4.8.2 The scantlings of the end connection of each stiffener are to comply with **Section 4/3.4**.

7. Application of Scantling Requirements to Other Structure

7.1 General

7.1.1 Application

7.1.1.1 The requirements of this Sub-Section apply to plating, local and primary support members where the basic structural configurations or strength models assumed in **Section 8/2 to 8/5** are not appropriate. These are general purpose strength requirements to cover various load assumptions and end support conditions. These requirements are not to be used as an alternative to the requirements of **Section 8/2 to 8/5** where those sections can be applied.

7.1.1.2 The net scantlings described in **7.2** are related to gross scantlings as follows:

- for plating and local support members, the gross thickness and gross cross-sectional properties are obtained from the requirements of **7.2.2** by adding the full corrosion additions specified in **Section 6/3**.
- for primary support members, the gross shear area, gross section modulus and other gross cross-sectional properties are obtained from the requirements of **7.2.3** by adding one half of the relevant full corrosion additions specified in **Section 6/3**.

7.1.1.3 These requirements are to be applied in conjunction with all other appropriate requirements in **Sections 8, 9** and **10** for the particular structural member under consideration, including longitudinal strength, minimum thickness, proportions and structural stability, strength assessment (FEM), fatigue and hull girder ultimate strength.

7.1.1.4 The requirements for local and primary support members are to be specially considered when the member is:

- part of a grillage structure
- subject to large relative deflection between end supports
- where the load model or end support condition is not given in **Table 8.7.1**.

7.1.1.5 The application of alternative or more advanced calculation methods will be specially considered.

7.2 Scantling Requirements

7.2.1 General

7.2.1.1 The design load sets to be applied to the structural requirements for the local and primary support members are given in **Table 8.7.2**, as applicable for the particular structure under consideration. The static and dynamic load components are to be combined in accordance with **Table 7.6.1** and the requirements given in **Section 7/6.3**.

7.2.2 Plating and local support members

7.2.2.1 For plating subjected to lateral pressure the net thickness, t_{net} , is to be taken as the greatest value for all applicable design load sets given in **Table 8.7.2**, and given by:

$$t_{net} = 0.0158 \alpha_p s \sqrt{\frac{|P|}{C_a \sigma_{yd}}} \quad (mm)$$

Where:

α_p : correction factor for the panel aspect ratio

$$= 1.2 - \frac{s}{2100l_p}$$

P : design pressure for the design load set being considered, calculated at the load calculation point defined in **Section 3/5.1.2**, in kN/m^2

s : stiffener spacing, in mm , as defined in **Section 4/2.2**

l_p : length of plate panel, to be taken as the spacing of primary support members, S , unless carlings are fitted, in m

C_a : permissible bending stress coefficient for the design load set being considered, as given in **Tables 8.2.4, 8.3.2** or **8.4.2**, as applicable for the individual member being considered

σ_{yd} : specified minimum yield stress of the material, in N/mm^2

7.2.2.2 For stiffeners subjected to lateral pressure, point loads, or some combination thereof, the net section modulus requirement, Z_{net} , is to be taken as the greatest value for all applicable design load sets given in **Table 8.7.2**, and given by:

$$Z_{net} = \frac{|P|s l_{bdg}^2}{f_{bdg} C_s \sigma_{yd}} \quad (cm^3), \text{ for lateral pressure loads}$$

$$Z_{net} = \frac{1000 |F| l_{bdg}}{f_{bdg} C_s \sigma_{yd}} \quad (cm^3), \text{ for point loads}$$

$$Z_{net} = \frac{\left| \sum \frac{P_i s l_{bdg}^2}{f_{bdg-i}} + \sum \frac{1000 F_j l_{bdg}}{f_{bdg-j}} \right|}{C_s \sigma_{yd}} \quad (cm^3), \text{ for a combination of loads}$$

Where:

- P : design pressure for the design load set being considered, calculated at the load calculation point defined in **Section 3/5.2.2**, in kN/m^2
- s : stiffener spacing, in mm , as defined in **Section 4/2.2**
- l_{bdg} : effective bending span, as defined in **Section 4/2.1.1**
- f_{bdg} : bending moment factor
 for continuous stiffeners and where end connections are fitted consistent with idealization of the stiffener as having fixed ends
 = 12 for horizontal stiffeners
 = 10 for vertical stiffeners
 for other configurations the bending moment factor may be taken as in **Table 8.7.1**
- C_s : permissible bending stress coefficient for the design load set being considered as given in **Tables 8.2.5, 8.3.3 or 8.4.3**, as applicable for the individual member being considered
- σ_{yd} : specified minimum yield stress of the material, in N/mm^2
- F : point load for the design load set being considered, in kN
- i : indices for load component i
- j : indices for load component j

7.2.2.3 For stiffeners subjected to lateral pressure, point loads, or some combination thereof, the net web thickness, t_{w-net} , based on shear area requirements is to be taken as the greatest value for all applicable design load sets given in **Table 8.7.2**, and given by:

$$t_{w-net} = \frac{f_{shr} |P| s l_{shr}}{d_{shr} C_t \tau_{yd}} \quad (mm), \text{ for lateral pressure loads}$$

$$t_{w-net} = \frac{1000 f_{shr} |F|}{d_{shr} C_t \tau_{yd}} \quad (mm), \text{ for point loads}$$

$$t_{w-net} = \frac{\left| \sum f_{shr-i} P_i s l_{shr} + \sum 1000 f_{shr-j} F_j \right|}{d_{shr} C_t \tau_{yd}} \quad (mm), \text{ for a combination of loads}$$

Where:

- P : design pressure for the design load set being considered, calculated at the load calculation point defined in **Section 3/5.2.2**, in kN/m^2
- f_{shr} : shear force factor
 for continuous stiffeners and where end connections are fitted consistent with idealization of the stiffener as having fixed ends:
 = 0.5 for horizontal stiffeners
 = 0.7 for vertical stiffeners
 for other configurations the shear force factor may be taken as in **Table 8.7.1**.
- s : stiffener spacing, in mm , as defined in **Section 4/2.2**

- l_{shr} : effective shear span, as defined in **Section 4/2.1.2**
 d_{shr} : as defined in **Section 4/2.4.2.2**
 C_t : permissible shear stress coefficient for the design load set being considered as given in **Tables 8.2.6** or **8.3.4**, as applicable for the individual member being considered
 $\bar{\tau}_{yd} = \frac{\sigma_{yd}}{\sqrt{3}}$ (N/mm^2)
 σ_{yd} : specified minimum yield stress of the material, in N/mm^2
 F : point load for the design load set being considered, in kN
 i : indices for load component i
 j : indices for load component j

7.2.3 Primary support members

7.2.3.1 The requirements in **7.2.3** are applicable where the primary support member is idealised as a simple beam. More advanced calculation methods may be required to ensure that nominal stress level for all primary support members are less than the permissible stresses and stress coefficients given in **7.2.3.4** and **7.2.3.5** when subjected to the applicable design load sets. See also **7.1.1.4**.

7.2.3.2 The section modulus and web thickness of the local support members apply to the areas clear of the end brackets. The section modulus and cross sectional shear areas of the primary support member are to be applied as required in the notes of **Table 8.7.1**.

7.2.3.3 For primary support members intersecting with or in way of curved hull sections, the effectiveness of end brackets is to include an allowance for the curvature of the hull.

7.2.3.4 For primary support members the net section modulus requirement, Z_{net50} , is to be taken as the greatest value for all applicable design load sets given in **Table 8.7.2**, and given by:

$$Z_{net50} = \frac{1000 |P| S l_{bdg}^2}{f_{bdg} C_s \sigma_{yd}} \quad (cm^3), \text{ for lateral pressure loads}$$

$$Z_{net50} = \frac{1000 |F| l_{bdg}}{f_{bdg} C_s \sigma_{yd}} \quad (cm^3), \text{ for point loads}$$

$$Z_{net50} = \frac{\left| \sum \frac{1000 P_i S l_{bdg}^2}{f_{bdg-i}} + \sum \frac{1000 F_j l_{bdg}}{f_{bdg-j}} \right|}{C_s \sigma_{yd}} \quad (cm^3), \text{ for a combination of loads}$$

Where:

- P : design pressure for the design load set being considered, calculated at the load calculation point defined in **Section 3/5.3.3**, in kN/m^2
 S : primary support member spacing, in m , as defined in **Section 4/2.2.2**
 l_{bdg} : effective bending span, as defined in **Section 4/2.1.4**
 f_{bdg} : bending moment factor, as given in **Table 8.7.1**.
 C_s : permissible bending stress coefficient for the design load set being considered as given in **Tables 8.2.10** or **8.3.6**, as applicable for the individual member being considered
 σ_{yd} : specified minimum yield stress of the material, in N/mm^2
 F : point load for the design load set being considered, in kN
 i : indices for load component i
 j : indices for load component j

7.2.3.5 For primary support members the net shear area of the web, $A_{shr-net50}$, is to be taken as the greatest value for all applicable design load sets given in **Table 8.7.2**, and given by:

$$A_{shr-net50} = \frac{10 f_{shr} |P| S l_{shr}}{C_t \tau_{yd}} \quad (cm^2), \text{ for lateral pressure loads}$$

$$A_{shr-net50} = \frac{10 f_{shr} |F|}{C_t \tau_{yd}} \quad (cm^2), \text{ for point loads}$$

$$A_{shr-net50} = \frac{|\sum 10 f_{shr-i} P_i l_{shr} + \sum 10 f_{shr-j} F_j|}{C_t \tau_{yd}} \quad (cm^2), \text{ for a combination of loads}$$

Where:

- P : design pressure for the design load set being considered, calculated at the load calculation point defined in **Section 3/5.3.2**, in kN/m^2
- S : primary support member spacing, in m , as defined in **Section 4/2.2.2**
- l_{shr} : effective shear span, as defined in **Section 4/2.1.5**
- f_{shr} : shear force factor, as given in **Table 8.7.1**
- C_t : permissible shear stress coefficient for the design load set being considered as given in **Tables 8.2.10** or **8.3.7**, as applicable for the individual member being considered
- $\tau_{yd} = \frac{\sigma_{yd}}{\sqrt{3}} \quad (N/mm^2)$
- σ_{yd} : specified minimum yield stress of the material, in N/mm^2
- F : point load for the design load set being considered, in kN
- i : indices for load component i
- j : indices for load component j

Table 8.7.1 Values of f_{bdg} and f_{shr}



Load and boundary conditions				Bending moment and shear force factor (based on load at mid span where load varies)			Application	
Load model	Position ⁽¹⁾			1	2	3		
	1 Support	2 Field	3 Support	f_{bdg1} f_{shr1}	f_{bdg2} -	f_{bdg3} f_{shr3}		
A					12.0	24.0	12.0	Built in at both ends. Uniform pressure distribution
					0.50	-	0.50	
B					-	14.2	8.0	Built in one end plus simply supported one end. Uniform pressure distribution
					0.38	-	0.63	
C					-	8.0	-	Simply supported, (both ends are free to rotate). Uniform pressure distribution
					0.50	-	0.50	
D					15.0	23.3	10.0	Built in both ends. Linearly varying pressure distribution
					0.30	-	0.70	
E					-	16.8	7.5	Built in one end plus simply supported one end. Linearly varying pressure distribution
					0.20	-	0.80	
F					-	-	2.0	Cantilevered beam. Uniform pressure distribution
					-	-	1.0	
G					8.0	8.0	8.0	Built in at both ends. Single point load in the centre of the span
					0.5	-	0.5	
H					$\frac{l^3}{a^2(l-a)}$	$\frac{l^4}{2a^2(l-a)^2}$	$\frac{l^3}{a(l-a)^2}$	Built in at both ends. Single point load, with load anywhere in the span
					$\frac{a^2(3l-2a)}{l^3}$	-	$\frac{(l-a)^2(l+2a)}{l^3}$	
I					-	4	-	Simply supported. Single point load in the centre of the span
					0.5	-	0.5	
J					-	$\frac{l^2}{a(l-a)}$	-	Simply supported. Single point load, load anywhere along the span
					$\frac{a}{l}$	-	$\frac{l-a}{l}$	

Table 8.7.1 (Continued) Values of f_{bdg} and f_{shr}

Note

1. The bending moment factor f_{bdg} for the support positions are applicable for a distance of $0.2l_{bdg}$ from the end of the effective bending span for both local and primary support members.
2. The shear force factor f_{shr} for the support positions are applicable for a distance of $0.2l_{shr}$ from the end of the effective shear span for both local and primary support members.
3. Application of f_{bdg} and f_{shr} for local support members:
 the section modulus requirement of local support members is to be determined using the lowest value of f_{bdg1} , f_{bdg2} and f_{bdg3}
 the shear area requirement of local support members is to be determined using the greatest value of f_{shr1} and f_{shr3} .
4. Application of f_{bdg} and f_{shr} for primary support members:
 the section modulus requirement within $0.2l_{bdg}$ from the end of the effective span is generally to be determined using the applicable f_{bdg1} and f_{bdg3} , however f_{bdg} is not to be taken greater than 12
 the section modulus of mid span area is to be determined using $f_{bdg} = 24$, or f_{bdg2} from the table if lesser
 the shear area requirement of end connections within $0.2l_{shr}$ from the end of the effective span is to be determined using $f_{shr} = 0.5$ or the applicable f_{shr1} or f_{shr3} , whichever is greater
 for models A through F the value of f_{shr} may be gradually reduced outside of $0.2l_{shr}$ towards $0.5f_{shr}$ at mid span where f_{shr} is the greater value of f_{shr1} and f_{shr3} .

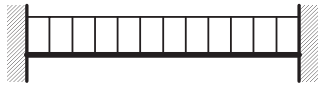
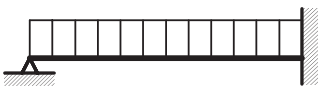
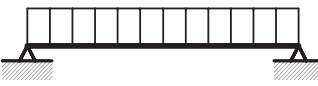
Where:

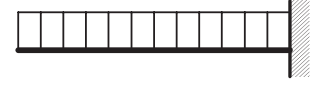
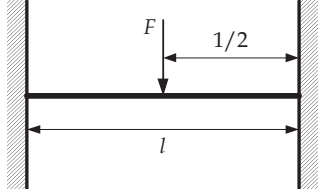
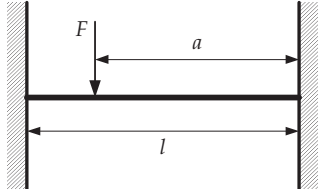
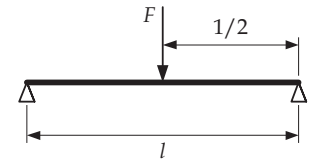
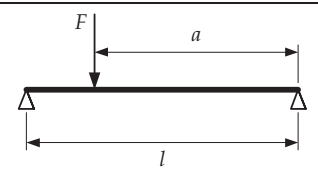
- l : effective span, l_{bdg} and l_{shr} as applicable
 l_{bdg} : as defined in **Section 4/2.1.1** for local support members and **Section 4/2.1.4** for primary support members
 l_{shr} : as defined in **Section 4/2.1.2** for local support members and **Section 4/2.1.5** for primary support members

Table 8.7.2 Design Load Sets for Plating, Local Support Members and Primary Support Members

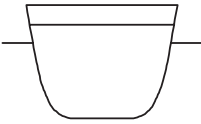
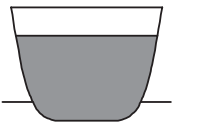
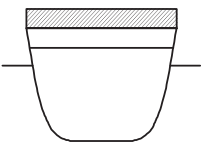
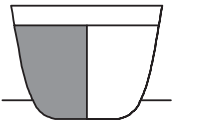
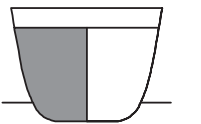
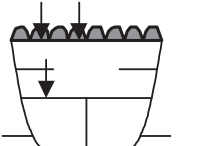
Type of Local Support and Primary Support Member	Design Load Set ⁽¹⁾	Load Component	External Draught	Comment	Diagrammatic Representation
Shell Envelope	1	P_{ex}	T_{sc}	Sea pressure only	
	2	P_{ex}	T_{sc}		
	5	P_{in}	T_{bal}	Tank pressure only. Sea pressure to be ignored	
	6	P_{in}	$0.25T_{sc}$		
External Decks	1	P_{ex}	T_{sc}	Green sea pressure only	
Cargo Tank Boundaries	3	P_{in}	$0.6T_{sc}$	Pressure from one side only Full tank with adjacent tank empty	
	4	P_{in}	-		
	11	$P_{in-flood}$	-		
Other Tank Boundaries or Watertight Boundaries	5	P_{in}	T_{bal}	Pressure from one side only Full tank with adjacent tank empty	
	6	P_{in}	$0.25T_{sc}$		
	11	$P_{in-flood}$	-		
Internal and External Decks or Flats	9	P_{dk}	T_{bal}	Distributed or concentrated loads only. Adjacent tanks empty. Green sea pressure may be ignored	
	10	P_{dk}	T_{bal}		

Where:

T_{sc} scantling draught, in m, as defined in Section 4/1.1.5.5

T_{bal} minimum design ballast draught, in m, as defined in Section 4/1.1.5.2

Notes

1. The specification of design load combinations, and other load parameters for the design load sets are given in **Table 8.2.8**
2. When the ship's configuration cannot be described by the above, then the applicable Design Load Sets to determine the scantling requirements of structural boundaries are to be selected so as to specify a full tank on one side with the adjacent tank or space empty. The boundary is to be evaluated for loading from both sides. Design Load Sets are to be selected based on the tank or space contents and are to maximise the pressure on the structural boundary, the draught to use is to be taken in accordance with the Design Load Set and this table. Design Load Sets covering the S and S+D design load combinations are to be selected. See Note 4 on **Table 8.2.7** and **Table 8.2.8**.
3. The boundaries of void and dry space not forming part of the hull envelope are to be evaluated using Design Load Set 11. See Note 2.

Section 9 DESIGN VERIFICATION

1. Hull Girder Ultimate Strength

1.1 General

1.1.1 Application

1.1.1.1 The hull girder ultimate bending capacity in sagging is to be evaluated and checked to ensure it satisfies the following criteria. The criteria are applicable to intact ship structures, in extreme at sea conditions. They do not cover hogging, harbour or damaged conditions.

1.1.1.2 The scantling requirements in this Sub-Section are to be applied to any cross section along the entire vessel's length and are in addition to all other requirements within the rules.

1.1.1.3 Outside the $0.4L_{CSR-T}$ region of amidships the plate and stiffeners may be gradually reduced towards the local requirements at the ends.

1.2 Rule Criteria

1.2.1 Vertical hull girder ultimate bending capacity

1.2.1.1 The vertical hull girder ultimate bending capacity is to satisfy the following criteria:

$$\gamma_S M_{sw} + \gamma_W M_{wv-sag} \leq \frac{M_U}{\gamma_R}$$

Where:

M_{sw} : sagging still water bending moment, in kNm , to be taken as specified in **Table 9.1.1**.

M_{wv-sag} : sagging vertical wave bending moment, in kNm , to be taken as the midship sagging value defined in **Section 7/3.4.1.1**

M_U : sagging vertical hull girder ultimate bending capacity, in kNm , as defined in **Appendix A/1.1.1**

$\gamma_S, \gamma_W, \gamma_R$: are the partial safety factors for the design load combinations given in **1.4**

1.3 Hull Girder Bending Moment Capacity

1.3.1 Calculation of capacity

1.3.1.1 The hull girder ultimate bending capacity, M_U , in sagging is to be calculated according to **Appendix A/1.1.1**.

1.3.1.2 The effective area for the hull girder ultimate strength capacity assessment is specified in **Section 8/1.2.1**.

1.3.1.3 The capacity is to be based on net scantlings using a corrosion addition, $0.5t_{corr}$, see **Section 6/3.2**

1.4 Partial Safety Factors

1.4.1 General

1.4.1.1 The partial safety factors given in **Table 9.1.1** apply when M_U is calculated according to the single step method in **Appendix A/2.1** or the incremental method in **A/2.2**. The partial safety factors are given for two different design load combinations and both combinations are to be satisfied. Note that the definition of M_{sw} is different for each combination.

Table 9.1.1 Partial Safety Factors

Design load combination	Definition of Still Water Bending Moment, M_{sw}	γ_S	γ_W	γ_R
a)	Permissible sagging still water bending moment, $M_{sw-perm-sea}$, in kNm , see Section 7/2.1.1	1.0	1.2	1.1
b)	Maximum sagging still water bending moment for operational seagoing homogeneous full load condition, $M_{sw-full}$, in kNm , see note 1	1.0	1.3	1.1

Where:

γ_S partial safety factor for the sagging still water bending moment

γ_W partial safety factor for the sagging vertical wave bending moment covering environmental and wave load prediction uncertainties

γ_R partial safety factor for the sagging vertical hull girder bending capacity covering material, geometric and strength prediction uncertainties

Notes

- 1 The maximum sagging still water bending moment is to be taken from the departure condition with the ship homogeneously loaded at maximum draught and corresponding arrival and any mid-voyage conditions.

2. Strength Assessment (FEM)

2.1 General

2.1.1 Application

2.1.1.1 A strength assessment of the hull structure using finite element analysis is mandatory.

2.1.1.2 The finite element analysis consists of two parts:

(a) cargo tank analysis to assess the strength of longitudinal hull girder structural members, primary supporting structural members and transverse bulkheads.

(b) fine mesh analysis to assess detailed stress levels in local structural details.

2.1.1.3 A flow diagram showing the minimum requirement of finite element analysis is shown in **Fig. 9.2.1**.

2.1.1.4 The structural assessment is to be carried out in accordance with the requirements given in **Appendix B**. The structural assessment is to verify that the acceptance criteria specified in **2.2.5** and **2.3.5** are complied with.

2.1.1.5 The application of the scantlings verified by the structural assessment within the cargo tank region is to be in accordance with **2.4**.

Fig. 9.2.1 Rule Minimum Requirement on Finite Element Analysis

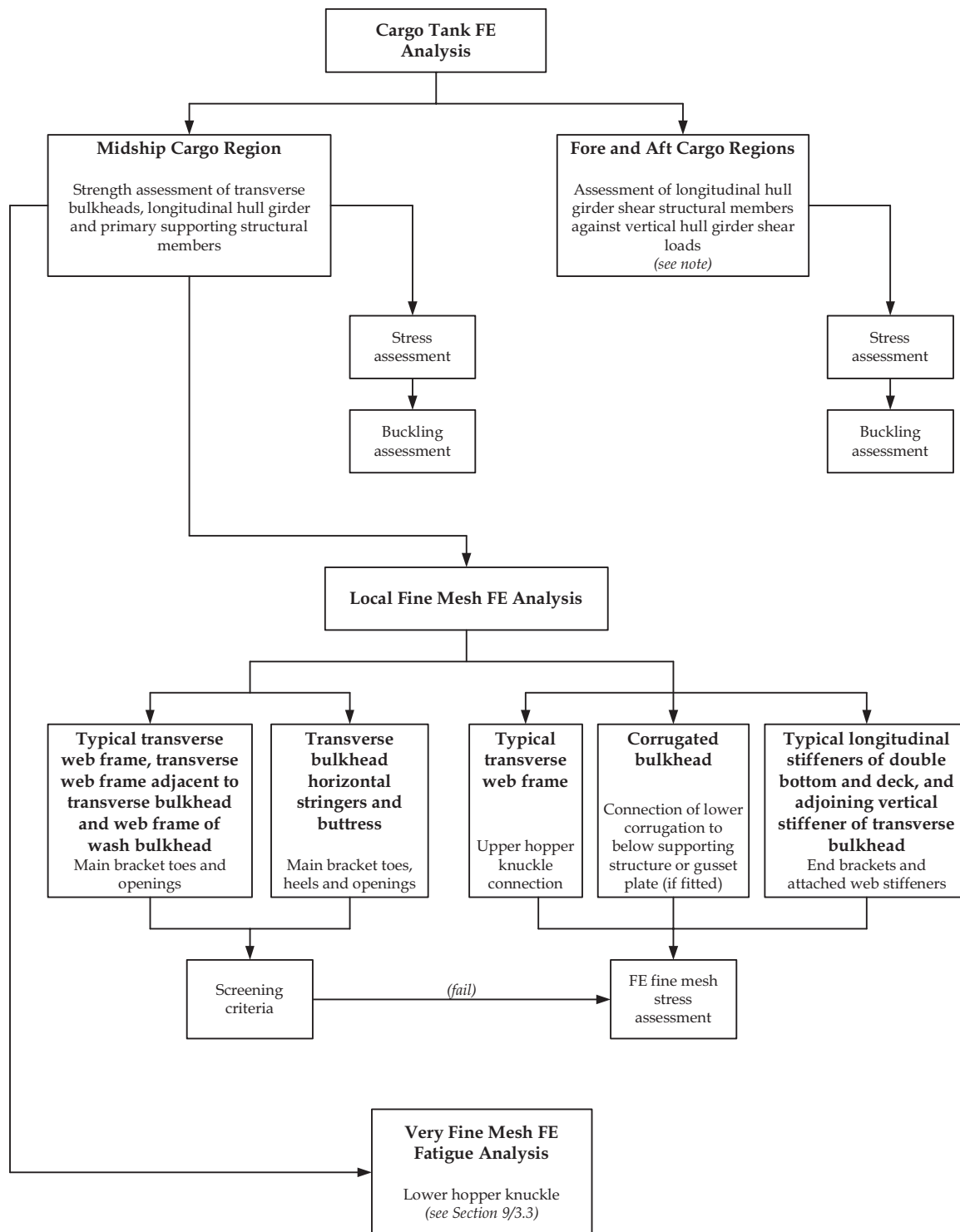

Note :

1. The strength assessment of longitudinal hull girder shear structural members, as defined in 2.2.1.1 and Section 4/Table 4.1.1, against hull girder vertical shear loads in way of transverse bulkheads may be based on the midship cargo tank finite element model with modification of plate and stiffener properties where appropriate, see Appendix B/1.1.1 and Appendix B/2.2.1.

2.1.2 Submission of results

2.1.2.1 A detailed report of the structural analysis is to be submitted to demonstrate compliance with the specified structural design criteria. This report shall include the following information:

- (a) list of plans used including dates and versions
- (b) detailed description of structural modelling including all modelling assumptions and any deviations in geometry and arrangement of structure compared with plans
- (c) plots to demonstrate correct structural modelling and assigned properties
- (d) details of material properties, plate thickness, beam properties used in the model
- (e) details of boundary conditions
- (f) details of all loading conditions reviewed with calculated hull girder shear force and bending moment distributions
- (g) details of applied loads and confirmation that individual and total applied loads are correct
- (h) plots and results that demonstrate the correct behaviour of the structural model under the applied loads
- (i) summaries and plots of global and local deflections
- (j) summaries and sufficient plots of stresses to demonstrate that the design criteria are not exceeded in any member
- (k) plate and stiffened panel buckling analysis and results
- (l) tabulated results showing compliance, or otherwise, with the design criteria
- (m) proposed amendments to structure where necessary, including revised assessment of stresses, buckling and fatigue properties showing compliance with design criteria.

2.1.3 Computer programs

2.1.3.1 In general, any finite element computation program recognised by the Society may be employed to determine the stress and deflection of the hull structure, provided that the combined effects of bending, shear, axial and torsional deformations are considered.

2.1.3.2 The computer program used for the assessment of panel buckling capability is to take account of the combined interaction of bi-axial compressive stresses, shear stress and lateral pressure loads, as required by **Section 10/4**.

2.1.3.3 A computer program that has been demonstrated to produce reliable results to the satisfaction of the Society is regarded as a recognised program. Where the computer programs employed are not supplied or recognised by the Society, full particulars of the computer program, including calculation output, are to be submitted for approval. It is recommended that the designers consult the Society on the suitability of the computer programs intended to be used prior to the commencement of any analysis work.

2.2 Cargo Tank Structural Strength Analysis

2.2.1 Objective and scope

2.2.1.1 The analysis is to cover at least the assessment of:

- (a) longitudinal hull girder structural members, primary supporting structural members and transverse bulkheads in the midship cargo tank region, and
- (b) Longitudinal hull girder shear structural members in way of transverse bulkheads against hull girder vertical shear loads within the cargo area. These structural members include side shell, inner hull longitudinal bulkheads including upper sloped plate where fitted, hopper, longitudinal bulkheads and double bottom girders as defined in **Section 4/Table 4.1.1**. The required strengthening in way of transverse bulkheads for hull girder shear loads in the forward, midship or aft cargo region may be based on the maximum hull girder shear force within the region considered. Alternatively assessment may be carried out to determine the strengthening requirement in way of individual transverse bulkhead position. The details are given in **Appendix B/1.1.1**.

2.2.1.2 The required strengthening in way of transverse bulkheads for hull girder shear loads in the forward, midship or aft cargo region may be based on the maximum hull girder shear force within the region considered. Alternatively assessment may be carried out to determine the strengthening requirement in way of individual transverse bulkhead position. The details are given in **Appendix B/1.1.1**

2.2.1.3 The analysis is to verify that the following are within the acceptance criteria under the applied static and dynamic loads:

- (a) stress level in the plating of longitudinal hull girder structural members, primary support structural members and transverse bulkheads, face plate of primary support members modelled by plate or rod elements.
- (b) buckling capability of plates and stiffened panels.

2.2.2 Structural modelling

2.2.2.1 The modelling scantlings of the cargo tank finite element model are to be based on net scantlings as described in **Section 6/3.3.6.1** and **Appendix B/2.2.1.5**.

2.2.2.2 The length of the cargo tank finite element model is to cover three cargo tank lengths. Where the tanks in the midship cargo region are of different lengths, the middle tank of the finite element model is to represent the cargo tank of the greatest length. All main longitudinal and transverse structural elements are to be represented in the finite element model. These include inner and outer shell, double bottom floor and girder system, transverse and vertical web frames, stringers, transverse and longitudinal bulkhead structures. All plating and stiffeners, including web stiffeners, on these structural elements are to be modelled.

2.2.2.3 The mesh of the finite element model is to follow the stiffening system of the structure as far as practical, and is to represent the actual plate panels between stiffeners.

2.2.2.4 The structure modelling is to be in accordance with the requirements given in **Appendix B/2.2**.

2.2.3 Loads and loading conditions

2.2.3.1 The combinations of the ship static and dynamic loads which are likely to impose the most onerous load regimes on the hull structure are to be investigated in the structural analysis.

2.2.3.2 The standard load cases to be used in the structural analysis are given in **Appendix B/2.3.1**. These load cases cover seagoing conditions (design load combination S + D) and harbour/tank testing conditions (design load combination S).

2.2.3.3 Where the loading conditions specified by the designer are not covered by the standard load cases then these additional loading conditions are to be examined, see also **Appendix B/2.3.1**.

2.2.4 Load applications and boundary conditions

2.2.4.1 All simultaneously acting hull girder and local loads are to be applied to the model. The application of local and hull girder loads to the finite element model is to be in accordance with the requirement given in **Appendix B/2.4** and **B/2.5**.

2.2.4.2 The boundary conditions to be applied are given in **Appendix B/2.6**.

2.2.5 Acceptance criteria

2.2.5.1 Verification of results against the acceptance criteria is to be carried out in accordance with **Appendix B/2.7**.

2.2.5.2 Verification of results against the acceptance criteria is to be carried out for all structural members within the longitudinal extent of the middle tanks of the three tank FE model, and the regions forward and aft of the middle tanks up to the extent of the transverse bulkhead stringer and buttress structure. For the assessment of shear strength in way of transverse bulkheads against hull girder shear loads, stress level and buckling capability of inner hull longitudinal bulkheads including upper sloped plate where fitted, side shell, longitudinal bulkheads, hopper and bottom longitudinal girders are to be verified against the acceptance criteria. See also **Appendix B/2.7.1**.

2.2.5.3 The structural analysis is to demonstrate that the permissible von Mises stress criteria and utilisation factor against buckling for plate and stiffened panels specified in **Tables 9.2.1** and **9.2.2** are not exceeded.

2.2.5.4 Capacity models used for the assessment of local buckling capability of plate and stiffened panels are to be based on deduction of full corrosion addition thickness from the plate and stiffeners, as described in **Section 6/3.3.6.2** and **Appendix B/2.7.3**.

2.2.5.5 Where a lower stool is not fitted to a transverse or longitudinal corrugated bulkhead, the maximum permissible stresses and buckling utilisation factors given in **Tables 9.2.1** and **9.2.2** are to be reduced by 10% for the corrugation and below supporting structure within the extent defined as follows:

- (a) Full height of the corrugation
- (b) Supporting structure for a transverse corrugated bulkhead - longitudinally within half a web frame space forward and aft of the bulkhead

(c) Supporting structure for a longitudinal corrugated bulkhead – transversely within three longitudinal stiffener spacings from each side of the bulkhead.

Table 9.2.1 Maximum Permissible Stresses

Structural component	Yield utilisation factor
Internal structure in tanks	
Plating of all non-tight structural members including transverse web frame structure, wash bulkheads, internal web, horizontal stringers, floors and girders. Face plate of primary support members modelled using plate or rod elements	$\lambda_y \leq 1.0$ (load combination $S + D$)
	$\lambda_y \leq 0.8$ (load combination S)
Structure on tank boundaries	
Plating of deck, sides, inner sides, hopper plate, bilge plate, plane and corrugated cargo tank longitudinal bulkheads. Tight floors, girders and webs	$\lambda_y \leq 0.9$ (load combination $S + D$)
	$\lambda_y \leq 0.72$ (load combination S)
Plating of inner bottom, bottom, plane transverse bulkheads and corrugated bulkheads.	$\lambda_y \leq 0.8$ (load combination $S + D$)
	$\lambda_y \leq 0.64$ (load combination S)

Where:

$$\lambda_y \quad \text{yield utilisation factor}$$

$$= \frac{\sigma_{vm}}{\sigma_{yd}} \quad \text{for plate elements in general}$$

$$= \frac{\sigma_{rod}}{\sigma_{yd}} \quad \text{for rod elements in general}$$

σ_{vm} von Mises stress calculated based on membrane stresses at element's centroid, in N/mm^2

σ_{rod} axial stress in rod element, in N/mm^2

σ_{yd} specified minimum yield stress of the material, in N/mm^2 , but not to be taken as greater than $315 N/mm^2$ for load combination $S + D$ in areas of stress concentration ⁽²⁾

Notes:

1. Structural items given in the table are for guidance only. Stresses for all parts of the FE model specified in **2.2.5.2** are to be verified against the permissible stress criteria. See also **Appendix B/2.7.1**
2. Areas of stress concentration are corners of openings, knuckle joints, toes and heels of primary supporting structural members and stiffeners
3. Where a lower stool is not fitted to a transverse or longitudinal corrugated bulkhead, the maximum permissible stresses are to be reduced by 10% in accordance with **2.2.5.5**.
4. The yield utilisation factor for plane and corrugated longitudinal bulkheads between cargo tanks may be taken as for non-tight structural members for FE load cases where either both sides of the bulkhead are empty or both sides are loaded. The water-tight bottom girder under the longitudinal bulkhead is to be treated as a tight structural member.

Table 9.2.2 Maximum Permissible Utilisation Factor Against Buckling

Structural component	Buckling utilisation factor
Plate and stiffened panels ⁽³⁾	$\eta \leq 1.0$ (load combination S + D)
	$\eta \leq 0.8$ (load combination S)
Web plate in way of openings	$\eta \leq 1.0$ (load combination S + D)
	$\eta \leq 0.8$ (load combination S)
Pillar buckling of cross tie structure	$\eta \leq 0.75$ (load combination S + D)
	$\eta \leq 0.65$ (load combination S)
Corrugated bulkheads flange buckling column buckling	$\eta \leq 0.9$ (load combination S + D)
	$\eta \leq 0.72$ (load combination S)

Where:

η : utilisation factor against buckling calculated in accordance with **Appendix D/5** and **Appendix B/2.7.3**. Also see **Section 10/3.4.1** for web plate in way of openings and **Section 10/3.5.1** for cross tie structure

Note :

1. Buckling capability of curved panels (e.g. bilge plate), face plate and tripping bracket of primary supporting members are not assessed based on finite element stress result
2. Where a lower stool is not fitted to a transverse or longitudinal corrugated bulkhead, the maximum permissible buckling utilisation factors are to be reduced by 10% in accordance with **2.2.5.5**
3. Permissible buckling utilisation factors specified in this table are applicable for the reference advanced buckling method given in **Appendix D/1.1.2**. If alternative buckling procedures are used the permissible utilisation factors are to be assessed and if required adjusted to meet acceptance criteria for equivalence specified in **Appendix D/1.1.2**.

2.3 Local Fine Mesh Structural Strength Analysis

2.3.1 Objective and scope

2.3.1.1 For tankers of conventional arrangements, as a minimum requirement, the following areas in the midship cargo region are to be investigated:

- (a) main bracket toes and openings at critical locations and upper hopper knuckle joint of a typical transverse web frame located in the midship tank. Where a wash bulkhead is fitted, main bracket toes and openings at critical locations of transverse and vertical webs
- (b) main bracket toes and openings at critical locations on a typical transverse web frame adjacent to a transverse bulkhead in way of the transverse bulkhead horizontal stringers
- (c) main bracket toes, heels and openings at critical locations of horizontal stringers, connection of transverse bulkhead to double bottom girder or buttress of a typical transverse bulkhead
- (d) connections of transverse and longitudinal corrugated bulkheads to bottom stool or inner bottom and double bottom supporting structure if a lower stool is not fitted. If a gusset plate is fitted the connection between the corrugation and the upper corners of the gusset are to be assessed
- (e) end brackets and attached web stiffeners of typical longitudinal stiffeners of double bottom and deck, and adjoining vertical stiffener of transverse bulkhead. If longitudinal stiffeners are fitted above the deck then the connection in way of the transverse bulkhead are to be assessed.

2.3.1.2 The selection of critical locations on the structural members described in **2.3.1.1** to perform fine mesh analysis is to be in accordance with **Appendix B/3.1**.

2.3.1.3 Where the stress level in areas of stress concentration on structural members not specified in **2.3.1.1** exceeds the acceptance criteria of the cargo tank analysis, a fine mesh analysis is to be carried out to demonstrate satisfactory scantlings.

2.3.1.4 Where the geometry can not be adequately represented in the cargo tank finite element model, a fine mesh analysis may be used to demonstrate satisfactory scantlings. In such cases the average stress within an area equivalent to that specified in the cargo tank analysis (typically s by s) is to comply with the requirement given in **Table 9.2.1**. See also Note 1 of **Table 9.2.3**.

2.3.2 Structural modelling

2.3.2.1 The fine mesh structural models are to be in accordance with the requirements given in **Appendix B/3.2**.

2.3.2.2 The fine mesh analysis may be carried out by means of a separate local finite element model with fine mesh zones, in conjunction with the boundary conditions obtained from the cargo tank model, or by incorporating fine mesh zones into the cargo tank model.

2.3.2.3 The extent of the local finite element models is to be such that the calculated stresses at the areas of interest are not significantly affected by the imposed boundary conditions and application of loads. Detailed requirements on the extension of local finite element models are given in **Appendix B/3.2**.

2.3.2.4 The fine mesh zone is to represent the localised area of high stress. The finite element mesh size within the fine mesh zones is to be not greater than $50\text{mm} \times 50\text{mm}$. The extent of the fine mesh zone is to be in accordance with **Appendix B/3.2**.

2.3.2.5 The fine mesh models are to be based on the net scantlings in accordance with **Section 6/3.3.6.3** and **Appendix B/3.2**.

2.3.3 Loads and loading conditions

2.3.3.1 Fine mesh detailed stress analysis is to be carried out for the standard load cases, and any other specifically specified load cases, required by **2.2.3**.

2.3.4 Load applications and boundary conditions

2.3.4.1 The application of loads and boundary conditions to the finite element model is to be in accordance with the requirements given in **Appendix B/3.4**.

2.3.5 Acceptance criteria

2.3.5.1 Verification of stress results against the acceptance criteria is to be carried out in accordance with **Appendix B/3.5**.

2.3.5.2 The structural assessment is to demonstrate that the von Mises stresses obtained from the fine mesh finite element analysis do not exceed the maximum permissible stress criteria specified in **Table 9.2.3**.

Table 9.2.3 Maximum Permissible Membrane Stresses for Fine Mesh Analysis

Element stress	Yield utilisation factor
Element not adjacent to weld	$\lambda_y \leq 1.7$ (load combination S + D)
	$\lambda_y \leq 1.36$ (load combination S)
Element adjacent to weld	$\lambda_y \leq 1.5$ (load combination S + D)
	$\lambda_y \leq 1.2$ (load combination S)

Where:

$$\begin{aligned} \lambda_y &: \text{yield utilisation factor} \\ &= \frac{k \sigma_{vm}}{235} \quad \text{for plate element} \\ &= \frac{k \sigma_{rod}}{235} \quad \text{for rod or beam element} \end{aligned}$$

σ_{vm} : von Mises stress calculated based on membrane stress at element's centroid, in N/mm^2

σ_{rod} : yield utilisation factor

k : higher strength steel factor, as defined in **Section 6/1.1.4** but not to be taken as less than 0.78 for load combination S + D

Note :

1. Where the von Mises stress of the elements in the cargo tank FE model in way of the area under investigation by fine mesh exceeds its permissible value specified in **Table 9.2.1**, average von Mises stress, obtained from the fine mesh analysis, calculated over an area equivalent to the mesh size of the cargo tank finite element model is to be less than the permissible value specified in **Table 9.2.1**
2. The maximum permissible stresses are based on the mesh size of $50mm \times 50mm$. Where a smaller mesh size is used, an average von Mises stress calculated in accordance with **Appendix B/3.5.1** over an area equal to the specified mesh size may be used to compare with the permissible stresses.
3. Average von Mises stress is to be calculated based on weighted average against element areas:

$$\sigma_{vm-av} = \frac{\sum_1^n A_i \sigma_{vm-i}}{\sum_1^n A_i}$$

where

σ_{vm-av} is the average von Mises stress

σ_{vm-i} is the von Mises stress of the i th plate element within the area considered

A_i is the area of the i th plate element within the area considered

n is the number of elements within the area considered

4. Stress averaging is not to be carried across structural discontinuities and abutting structure
5. Where a lower stool is not fitted to a transverse or longitudinal corrugated bulkhead, the maximum permissible stresses are to be reduced by 10% for the areas under investigation by fine mesh analysis.

2.4 Application of Scantlings in Cargo Tank Region

2.4.1 General

2.4.1.1 The application of the scantlings that comply with the requirements of the finite element strength assessment, to the structure within the cargo tank region, is to be in accordance with the requirements given in this **sub-section**.

2.4.1.2 The application given in this **sub-section** assumes that the same material yield strength of the structure is maintained throughout the cargo tank region. Where steel having a different yield strength is applied, the required scantlings are to be assessed.

2.4.1.3 The scaling procedure given in this **sub-section** is based on scantlings that satisfied the requirements given in **Section 9/2** and **Appendix B**.

2.4.1.4 The net thickness and sectional properties for plating and local support members described in this **sub-section** are to be based on deduction of full corrosion addition, as specified in **Section 6/Table 6.3.2**, from the

gross scantlings. The gross thickness of plating, web and face plate of local support members are to be obtained by adding the full corrosion addition to the net thickness.

2.4.2 Application of scantlings to deck

2.4.2.1 The scantlings of deck plating and deck longitudinal stiffeners are to be maintained longitudinally within $0.4L_{CSR-T}$ amidships. The scantlings of deck plating and deck longitudinal stiffeners at a given transverse location within $0.4L_{CSR-T}$ amidships are not to be taken as less than the maximum of that required for the corresponding transverse location along the length of the middle tanks of the cargo tank finite element model required by **Appendix B/1.1.1.5**.

2.4.2.2 Outside $0.4L_{CSR-T}$ amidships, the scantlings of the deck plating and deck longitudinal stiffeners may be tapered to that required by **Section 8** at the ends of the cargo tank region.

2.4.3 Application of scantlings to inner bottom

2.4.3.1 The thickness of inner bottom plating may vary along the length and breadth of a tank.

2.4.3.2 The scantlings of the inner bottom plating and longitudinal stiffeners of midship cargo tanks are not to be less than that required for the corresponding location of the middle tanks of the cargo tank finite element model required by **Appendix B/1.1.1.5**. These scantlings are to be maintained for all tanks within the cargo region, other than the fore-most and aft-most cargo tanks.

2.4.3.3 For the fore-most and aft-most cargo tanks, the scantlings of the inner bottom longitudinal stiffeners are not to be less than the scantling requirements for the midship cargo tanks provided that the spacing of primary support members are not reduced in the forward and/or aft cargo tank. The minimum net thickness of the inner bottom plate, t_{ib-net} , is given by:

$$t_{ib-net} = t_{ib-net-mid} \left(\frac{l_{bdg}}{l_{bdg-mid}} \right)^{0.25} \frac{S_{ib}}{S_{ib-mid}} \quad (mm)$$

where:

- $t_{ib-net-mid}$: required net thickness of the inner bottom plating for the corresponding location in the midship tank, in *mm*
- l_{bdg} : effective bending span, of floor at location under consideration, in accordance with **Fig. 4.2.7**, in *m*
- $l_{bdg-mid}$: effective bending span, of floor at corresponding location in midship tank, defined in accordance with **Fig. 4.2.7**, in *m*
- S_{ib} : spacing between longitudinal stiffeners at location under consideration, in *mm*
- S_{ib-mid} : spacing between longitudinal stiffeners at corresponding location in midship tank, in *mm*

2.4.4 Application of scantlings to bottom

2.4.4.1 The scantlings of bottom longitudinal stiffeners are to be maintained longitudinally within $0.4L_{CSR-T}$ amidships. The scantlings of the bottom longitudinal stiffener at a given transverse location within $0.4L_{CSR-T}$ amidships are not to be less than the maximum of that required for the corresponding transverse location along the length of the middle tanks of the cargo tank finite element model required by **Appendix B/1.1.1.5**.

2.4.4.2 Outside $0.4L_{CSR-T}$ amidships, the scantlings of the bottom longitudinal stiffeners may be tapered to that required by **Section 8** at the ends of the cargo region.

2.4.4.3 The thickness of the bottom plating may vary along the length and breadth of a tank. The bottom plate thicknesses of midship tanks are not to be less than that required for the corresponding location of the middle tanks of the cargo tank finite element model required by **Appendix B/1.1.1.5**. These thicknesses are to be maintained for all tanks within the cargo region, other than the fore-most and aft-most cargo tanks.

2.4.4.4 For the fore-most and aft-most cargo tanks, the required minimum net thickness of the bottom plating, $t_{btm-net}$ is to be obtained as follows:

$$t_{btm-net} = t_{btm-net-mid} \left(\frac{l_{bdg}}{l_{bdg-mid}} \right)^{0.25} \frac{S_{btm}}{S_{btm-mid}} \quad (mm)$$

where:

$t_{btm-net-mid}$: required net thickness of the bottom plating for the corresponding location in the midship tank, in mm
l_{bdg}	: effective bending span, of floor at location under consideration, in accordance with Fig. 4.2.7 , in m
$l_{bdg-mid}$: effective bending span, of floor at corresponding location in midship tank, defined in accordance with Fig. 4.2.7 , in m
s_{btm}	: spacing between longitudinal stiffeners at location under consideration, in mm
$s_{btm-mid}$: spacing between longitudinal stiffeners at corresponding location in midship tank, in mm

2.4.5 Application of scantlings to side shell, longitudinal bulkheads and inner hull longitudinal bulkheads

2.4.5.1 The scantlings of plating and longitudinal stiffeners of side shell, longitudinal bulkheads and inner longitudinal bulkheads within $0.15D$ from the deck are to be maintained longitudinally within $0.4L_{CSR-T}$ amidships. The scantlings of plating and longitudinal stiffener at a given height are not to be less than the maximum of that required for the corresponding vertical location along the length of the middle tanks of the cargo tank finite element model required by **Appendix B/1.1.1.5**. Outside $0.4L_{CSR-T}$ amidships, the scantlings of the plating and stiffeners within $0.15D$ from the deck may be tapered to that required by **Section 8** at the ends of the cargo tank region.

2.4.5.2 The plate thickness of side shell, longitudinal bulkheads and inner hull longitudinal bulkheads, including hopper plating, outside $0.15D$ from the deck may vary along the length and height of a tank. The plate thickness away from the transverse bulkheads is not to be less than that required for the corresponding location of the middle tanks of the cargo tank finite element model required by **Appendix B/1.1.1.5**. These scantlings are to be maintained for all tanks within the cargo region, other than the fore-most and aft-most cargo tanks. For the fore-most and aft-most cargo tanks, the minimum net thickness of the side shell, longitudinal bulkheads or inner hull longitudinal bulkheads (including hopper plating) plating outside $0.15D$ from the deck is given by:

$$t_{net} = t_{net-mid} \frac{s}{s_{mid}} \quad (mm)$$

Where:

$t_{net-mid}$: required net thickness for corresponding location in the midship tank, in mm
s	: spacing between longitudinal stiffeners at location under consideration, in mm
s_{mid}	: spacing between longitudinal stiffeners at corresponding location in midship tank, in mm

2.4.5.3 The plate thickness of side shell, longitudinal bulkheads and inner hull longitudinal bulkheads, including hopper plating, in way of transverse bulkheads required for strengthening against hull girder shear loads is not to be less than that required by **Appendix B/1.1.1.6**, **B/1.1.1.7** and **B/1.1.1.8**. Within $0.15D$ from the deck, the plate thicknesses in way of transverse bulkheads are not to be taken as less than that required by **2.4.5.1**. Outside $0.15D$ from the deck, the plate thicknesses in way of transverse bulkheads are not to be taken as less than that required by **2.4.5.2**.

2.4.5.4 The scantlings of longitudinal stiffeners of side shell, longitudinal bulkheads, inner longitudinal bulkheads and hopper plate at a given height, outside $0.15D$ from the deck, are not to be less than that required for the corresponding vertical location of the middle tanks of the cargo tank finite element model as required by **Appendix B/1.1.1.5**. These scantlings are to be maintained for all tanks within the cargo region.

2.4.5.5 The plate thickness required for strengthening against hull girder shear loads of the side shell, longitudinal bulkheads and inner hull longitudinal bulkheads in way of a transverse bulkhead is to be taken as the greater from the corresponding vertical location of the forward and aft transverse bulkhead of the middle tanks of the cargo tank finite element model as required by **Appendix B/1.1.1.5**. All relevant requirements in other sections of the Rules are also to be complied with.

2.4.6 Application of scantlings to transverse bulkheads

2.4.6.1 The scantlings of transverse bulkhead plating, stiffeners and horizontal stringers may vary along the height and breadth of the bulkhead. The scantlings at a given location are not to be less than the maximum required at the

corresponding location of both middle tank end transverse bulkheads of the cargo tank finite element model as required by **Appendix B/1.1.1.5**.

2.4.7 Application of scantlings to primary structural support members

2.4.7.1 The web thickness of primary structural support members may vary along the length, breadth and height of a tank. The scantlings of the primary structural support members are not to be less than that required for the corresponding location of the middle tanks of the cargo tank finite element model required by **Appendix B/1.1.1.5**.

These scantlings are to be maintained for all tanks within the cargo region, other than the fore-most and aft-most cargo tanks.

2.4.7.2 Scantling requirements for primary support members in the fore-most and aft-most cargo tanks are to be determined by scaling the scantlings of the corresponding structural members in the midship tanks in accordance with **Section 8/2.6.9**.

2.4.8 Structural details and openings

2.4.8.1 Arrangement and scantlings of openings and structural details of primary structural members, complying with the requirements of **Appendix B/3**, are to be applied to the corresponding structural members in all tanks within the cargo tank region.

3. Fatigue Strength

3.1 Fatigue Evaluation

3.1.1 General

3.1.1.1 This Sub-Section, together with **Appendix C**, gives the minimum Rule requirements for design against fatigue failure for the structural details stipulated in this Part. Structural details at other locations that are considered to be critical may require assessment using a procedure consistent with that contained in this Part.

3.1.1.2 The fatigue criteria, applicable to a broad range of structural details and arrangements, are to be used for the assessment of fatigue strength utilising numerical techniques.

3.1.1.3 The fatigue analysis is to be carried out using either a 'nominal stress approach' or a 'hot spot stress approach' depending on the structural details, as specified in **3.4**. The procedure is illustrated in **Fig. 9.3.1**.

3.1.1.4 In a *nominal stress approach*, stresses in a structural component are calculated by using either analytical methods (e.g. a beam model) or using numerical methods (e.g. a coarse finite element mesh), based on the applied loads and the structural properties of the component.

3.1.1.5 In a *hot spot stress approach*, local stresses at a critical location (hot spot) where fatigue cracks may initiate are evaluated by numerical methods (e.g. a fine mesh finite element analysis). The analysis takes into account the influence of structural discontinuities due to the geometry of the connection but excludes the effects of welds.

3.2 Fatigue Criteria

3.2.1 Corrosion model

3.2.1.1 Net thicknesses in accordance with **Section 6/3.3.7** are to be used in the fatigue assessment.

3.2.2 Loads

3.2.2.1 The loads specified in **Section 7/3**, which are based on the North Atlantic wave environment, are to be used for the fatigue assessment. Other secondary cyclic loading, such as slamming, low cycle, or vibration induced fatigue, which may result in significant levels of stress range over the expected lifetime of the vessel, although not within the scope of this Part, may need to be specially considered.

3.2.2.2 This Part assumes a 10^{-4} probability level of exceedance for the purposes of load application and fatigue strength assessment.

3.2.3 Acceptance criteria

3.2.3.1 The criteria stated in this sub-section and **Appendix C** are presented as a comparison of fatigue strength of the structure (capacity), and fatigue inducing loads (demands), in the form of a fatigue damage parameter, DM , see **Appendix C/1.4.1.1**. The calculated fatigue damage, DM , is to be less than or equal to 1 for the design life of the ship, which is not to be taken as less than 25 years.

Fig. 9.3.1 Schematic of Fatigue Assessment Process (For Each Location or Structural Detail)

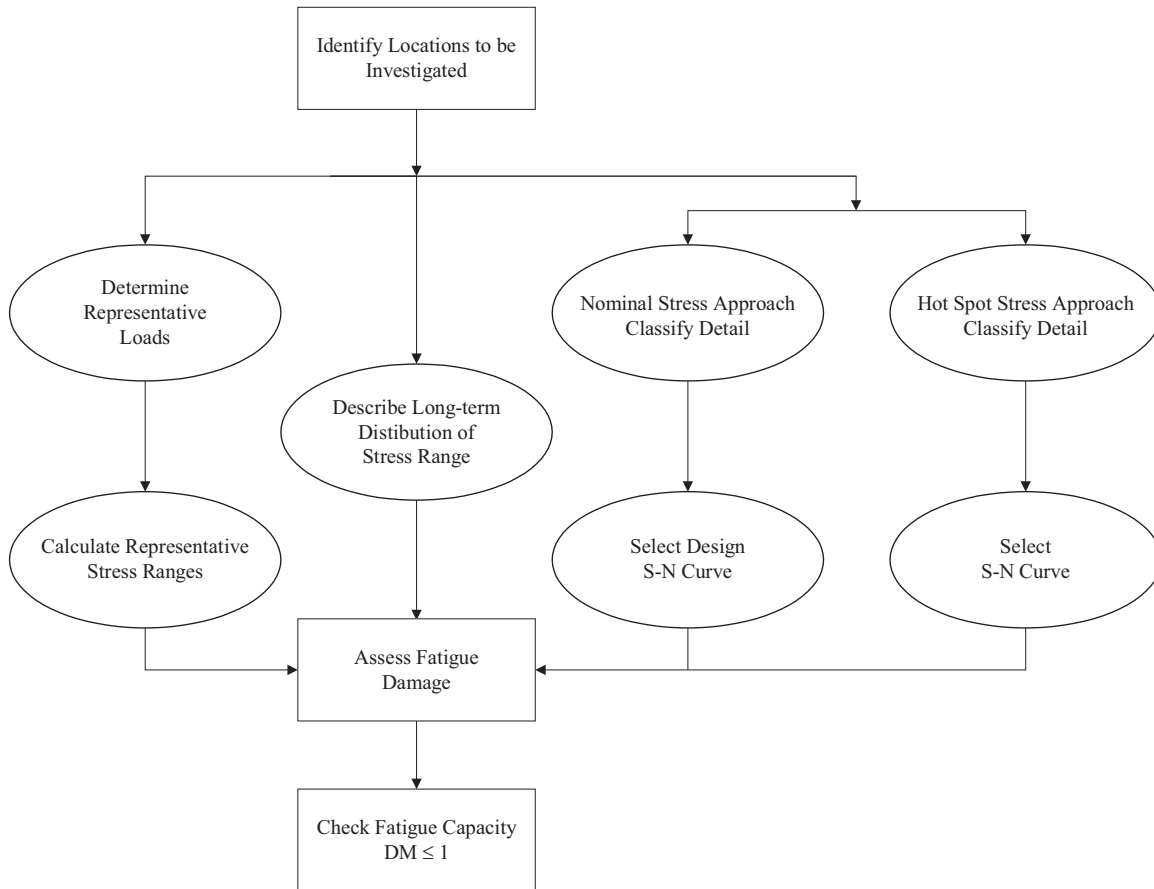

3.3 Locations to Apply

3.3.1 Longitudinal structure

3.3.1.1 A fatigue strength assessment is to be carried out and submitted for the end connections of longitudinal stiffeners to transverse bulkheads, including wash bulkheads and web frames within the cargo tank region, located on the bottom shell, inner bottom, side shell, inner hull longitudinal bulkheads, longitudinal bulkheads and strength deck.

3.3.1.2 A fatigue strength assessment is to be carried out for scallops in way of block joints on the strength deck within the cargo tank region.

3.3.2 Transverse structure

3.3.2.1 A fatigue strength assessment is to be carried out and submitted for the knuckle between inner bottom and hopper plate for at least one transverse frame close to amidships. The total stress range for fatigue assessment is to be determined from a fine mesh finite element analysis.

3.4 Fatigue Assessment Methods

3.4.1 Nominal stress approach

3.4.1.1 The nominal stress approach, as described in **Appendix C/1**, is to be used for the fatigue evaluation of the following items:

- (a) longitudinal stiffener end connections to the transverse bulkheads, including wash bulkheads, and web frames on the bottom, inner bottom, side shell, inner hull longitudinal bulkheads, longitudinal bulkheads and strength deck.
- (b) scallops in way of block joints on the strength deck as described in **Appendix C/1.6**.

3.4.2 Hot spot stress approach

3.4.2.1 The hot spot stress approach, as described in **Appendix C/2**, is to be used for the fatigue evaluation of the following items:

- (a) knuckle between inner bottom and hopper plate.

3.4.3 Alternative direct calculation approach

3.4.3.1 Where it is considered necessary to carry out a fatigue assessment using an alternative direct calculation approach, not applying the loads specified in **Section 7/3**, it is to be based on the Society's procedures. However, in no case are the scantlings to be lower than those which would be required by **3.4.1** and **3.4.2**.

Section 10 BUCKLING AND ULTIMATE STRENGTH

1. General

1.1 Strength Criteria

1.1.1 Scope

1.1.1.1 This Section contains the strength criteria for buckling and ultimate strength of local support members, primary support members and other structure such as pillars, corrugated bulkheads and brackets. These criteria are to be applied as specified in **Section 8** for determining the initial structural scantlings and also **Section 9** for the design verification.

1.1.1.2 All structural elements are to comply with the stiffness and proportions requirements specified in **Sub-Section 2**.

1.1.1.3 For each structural member the characteristic buckling strength is to be taken as the most unfavourable/critical buckling mode.

1.1.1.4 The strength criteria are to be based on the following assumptions and limitations in respect to buckling and ultimate strength control in design:

- (a) the buckling strength of stiffeners is to be greater than the plate panels they support
- (b) the primary support members supporting stiffeners are to have sufficient inertia to prevent out of plane buckling of the primary member, see **2.3.2.3**
- (c) all stiffeners with their associated effective plate are to have moments of inertia to provide adequate lateral stability, see **2.2.2**
- (d) the proportions of local support members and primary support members are to be such that local instability is prevented
- (e) tripping of primary support members (e.g. torsional instability) is to be prevented by fitment of tripping brackets or equivalents, see in **2.3.3**
- (f) the web plate of primary support members is to be such that elastic buckling of the plate between web stiffeners is prevented
- (g) for plates with openings, the buckling strength of the areas surrounding the opening or cut out and any edge reinforcements are adequate, see **3.4.1** and **2.4.3**.

2. Stiffness and Proportions

2.1 Structural Elements

2.1.1 General

2.1.1.1 All structural elements are to comply with the applicable slenderness or proportional ratio requirements in 2.2 to 2.3.

2.1.1.2 The following requirements are based on net scantlings, see also Section 6/3.

2.1.1.3 For structural idealisation and definitions see Section 4/2.

2.2 Plates and Local Support Members

2.2.1 Proportions of plate panels and local support members

2.2.1.1 The net thickness of plate panels and stiffeners is to satisfy the following criteria:

(a) plate panels

$$t_{net} \geq \frac{s}{C} \sqrt{\frac{\sigma_{yd}}{235}}$$

(b) stiffener web plate

$$t_{w-net} \geq \frac{d_w}{C_w} \sqrt{\frac{\sigma_{yd}}{235}}$$

(c) flange/face plate

$$t_{f-net} \geq \frac{b_{f-out}}{C_f} \sqrt{\frac{\sigma_{yd}}{235}}$$

Where:

s : plate breadth, in mm , taken as the spacing between the stiffeners, as defined in Section 4/2.2.1

t_{net} : net thickness of plate, in mm

d_w : depth of stiffener web, in mm , as given in Table 10.2.1

t_{w-net} : net web thickness, in mm

b_{f-out} : breadth of flange outstands, in mm , as given in Table 10.2.1

t_{f-net} : net flange thickness, in mm

C, C_w, C_f : slenderness coefficients, as given in Table 10.2.1

σ_{yd} : specified minimum yield stress of the material, in N/mm^2

Table 10.2.1 Slenderness Coefficients

Item		Coefficient
plate panel, C	hull envelope and tank boundaries	100
	other structure	125
stiffener web plate, C_w	angle and T profiles	75
	bulb profiles	41
	flat bars	22
flange/face plate ⁽¹⁾ , C_f	angle and T profiles	12

Notes :

1. The total flange breadth, b_f , for angle and T profiles is not to be less than: $b_f = 0.25d_w$
2. Measurements of breadth and depth are based on gross scantlings.

Where:

- t_{net} : net thickness of plate, in mm
- d_w : depth of web plate, in mm
- t_{w-net} : net web thickness, in mm
- b_{f-out} : breadth of flange outstands, in mm
- t_{f-net} : net flange thickness, in mm

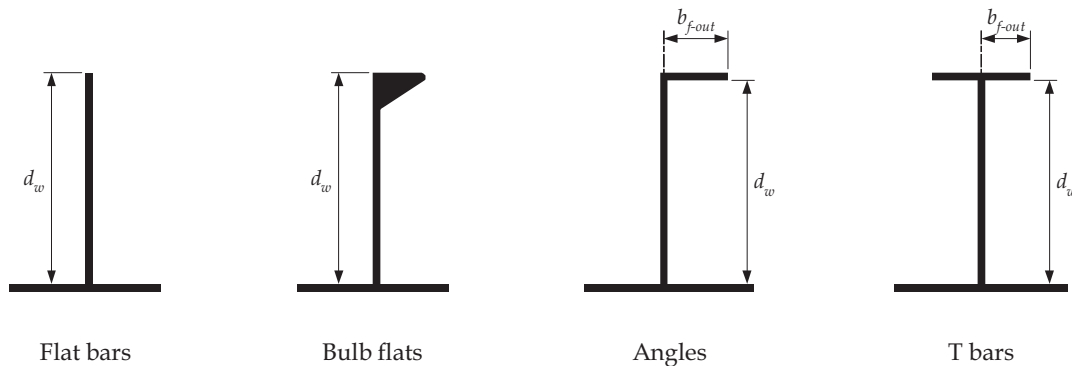

2.2.2 Stiffness of stiffeners

2.2.2.1 The minimum net moment of inertia about the neutral axis parallel to the attached plate, I_{net} , of each stiffener with effective breadth of plate equal to 80% of the stiffener spacing s , is given by:

$$I_{net} = Cl_{stf}^2 A_{net} \frac{\sigma_{ydl}}{235} \quad (cm^4)$$

Where:

- l_{stf} : length of stiffener between effective supports, in m
- A_{net} : net sectional area of stiffener including attached plate assuming effective breadth of 80% of stiffener spacing s , in cm^2
- s : stiffener spacing, in mm , as defined in **Section 4/2.2.1**
- σ_{ydl} : specified minimum yield stress of the material of the attached plate, in N/mm^2
- C : slenderness coefficient
 - = 1.43 for longitudinals subject to hull girder stresses
 - = 0.72 for other stiffeners

2.3 Primary Support Members

2.3.1 Proportions of web plate and flange/face plate

2.3.1.1 The net thicknesses of the web plates and face plates of primary support members are to satisfy the following criteria:

(a) web plate

$$t_{w-net} \geq \frac{s_w}{C_w} \sqrt{\frac{\sigma_{yd}}{235}}$$

(b) flange/face plate

$$t_{f-net} \geq \frac{b_{f-out}}{C_f} \sqrt{\frac{\sigma_{yd}}{235}}$$

Where:

s_w : plate breadth, in *mm*, taken as the spacing between the web stiffeners. For web plates with stiffening parallel to the attached plate the spacing may be corrected in accordance with **Appendix D/Fig. 5.6**.

t_{w-net} : net web thickness, in *mm*

b_{f-out} : breadth of flange outstand, in *mm*

t_{f-net} : net flange thickness, in *mm*

C_w : slenderness coefficient for the web plate

$$= 100$$

C_f : slenderness coefficient for the flange/face plate

$$= 12$$

σ_{yd} : specified minimum yield stress of the material, in *N/mm²*

2.3.2 Stiffness requirements

2.3.2.1 The web and flange net thicknesses of web stiffeners are not to be less than specified in **2.2.1**.

2.3.2.2 The net moment of inertia of each web stiffener, I_{net} , with effective breadth of plate equal to 80% of stiffener spacing s , is not to be less than as defined in **Table 10.2.2**.

2.3.2.3 The net moment of inertia for primary support members, $I_{psm-net50}$, supporting stiffeners subject to axial compressive stresses, including effective plate width at mid span, is not to be less than:

$$I_{psm-net50} = 300 \frac{l_{bdg}^4}{S^3 s} I_{net} \quad (cm^4)$$

Where:

l_{bdg} : bending span of primary support member, in *m*

S : distance between primary support members, in *m*

s : spacing of stiffeners, in *mm*, as defined in **Section 4/2.2.1**

I_{net} : maximum required moment of inertia, as given in **2.2.2.1**, for stiffeners within the central half of the bending span, in *cm⁴*

2.3.3 Spacing between flange supports or tripping brackets

2.3.3.1 The torsional buckling mode of primary support members is to be controlled by flange supports or tripping brackets. The unsupported length of the flange of the primary support member, i.e. the distance between tripping brackets, s_{bkt} , is not to be greater than:

$$s_{bkt} = b_f C \sqrt{\frac{A_{f-net50}}{\left(A_{f-net50} + \frac{A_{w-net50}}{3}\right) \left(\frac{235}{\sigma_{yd}}\right)}} \quad (m), \text{ but need not be less than } s_{bkt-min}$$

Where:

b_f : breadth of flange, in *mm*

C : slenderness coefficient

$$= 0.022 \text{ for symmetrical flanges}$$

$$= 0.033 \text{ for one sided flanges}$$

$A_{f-net50}$: net cross-sectional area of flange, in *cm²*

$A_{w-net50}$: net cross-sectional area of the web plate, in *cm²*

σ_{yd} : specified minimum yield stress of the material, in *N/mm²*

$S_{bkt-min}$ = 3.0m for primary support members in the cargo tank region, on tank boundaries or on the hull envelope including external decks
 = 4.0m for primary support members in other areas

Table 10.2.2 Stiffness Criteria for Web Stiffening

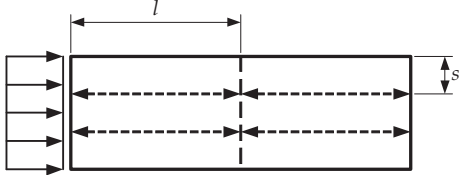
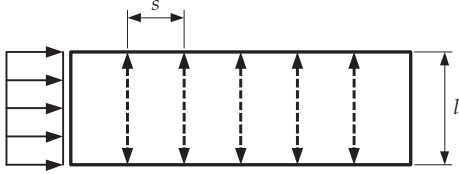
Mode	Inertia requirements, cm^4
(a) web stiffeners parallel to the flanges of the primary support member 	$I_{net} = Cl^2 A_{net} \frac{\sigma_{yd}}{235}$
(b) web stiffeners normal to flanges of the primary support member 	$I_{net} = 1.14 \times 10^{-5} l s^2 t_{w-net} \left(2.5 \frac{1000l}{s} - 2 \frac{s}{1000l} \right) \frac{\sigma_{yd}}{235}$

Where:

C = 1.43 for longitudinal stiffeners in cargo tank region
 = 0.72 for other stiffeners

l length of web stiffener, in m .

For web stiffeners welded to local support members (LSM), the length is to be measured between the flanges of the local support members.

For sniped web stiffeners the length is to be measured between the lateral supports e.g. the total distance between the flanges of the primary support member as shown for Mode (b).

A_{net} net section area of web stiffener including attached plate assuming effective breadth of 80% of stiffener spacing s , in cm^2

s spacing of stiffeners, in mm , as defined in **Section 4/2.2.1**

t_{w-net} net web thickness of the primary support member, in mm

σ_{yd} specified minimum yield stress of the material of the web plate of the primary support member, in N/mm^2

2.4 Other Structure

2.4.1 Proportions of pillars

2.4.1.1 For I-sections the thickness of the web plate and the flange thickness is to comply with **2.2.1.1**.

2.4.1.2 The thickness of thin walled box sections is to comply with **2.2.1.1(b)**. The radius of circular tube sections is to be less than 50 times the net thickness of the pillar.

2.4.2 Proportions of brackets

2.4.2.1 The net thickness of end brackets, $t_{bkt-net}$, is except as specified in **2.4.2.2** not to be less than:

$$t_{bkt-net} = \frac{d_{bkt}}{C} \sqrt{\frac{\sigma_{yd}}{235}} \quad (mm)$$

Where:

d_{bkt} : depth of brackets, in mm . See **Table 10.2.3**

C : slenderness coefficient as defined in **Table 10.2.3**

σ_{yd} : specified minimum yield stress of the material, in N/mm^2

2.4.2.2 Where it can be demonstrated that the bracket is only subjected to tensile stresses, e.g. in way of internal brackets in a tank surrounded by void space, the requirement in **2.4.2.1** need not be complied with.

Table 10.2.3 Buckling Coefficient, C , for Proportions of Brackets

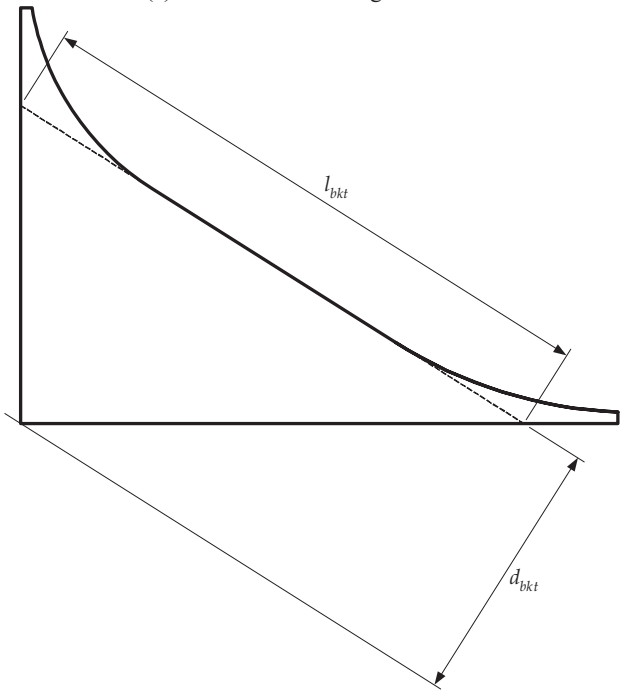
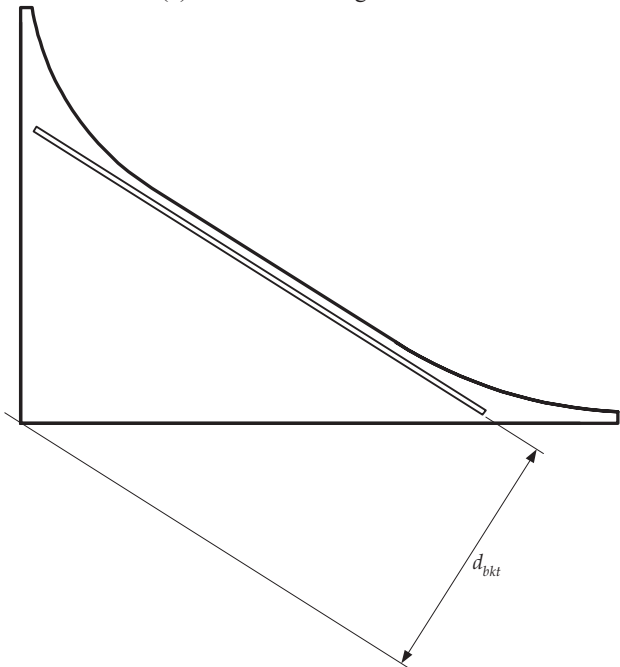
Mode	C
<p>(a) Brackets without edge stiffener</p> 	$C = 20 \left(\frac{d_{bkt}}{l_{bkt}} \right) + 16$ <p>Where:</p> $0.25 \leq \frac{d_{bkt}}{l_{bkt}} \leq 1.0$
<p>(b) Brackets with edge stiffener</p> 	$C = 70$

Where:

l_{bkt} : effective length of edge of bracket, in mm

2.4.2.3 Tripping brackets on primary support members are to be stiffened by a flange or edge stiffener if the effective length of the edge, l_{bkt} , is greater than:

$$l_{bkt} = 75t_{bkt-net} \quad (mm)$$

Where:

$t_{bkt-net}$: bracket thickness, in mm

2.4.3 Requirements to edge reinforcements in way of openings and bracket edges

2.4.3.1 The depth of stiffener web, d_w , of edge stiffeners in way of openings and bracket edges is not to be less than:

$$d_w = Cl\sqrt{\frac{\sigma_{yd}}{235}} \quad (mm), \text{ or } 50 \text{ mm, whichever is greater}$$

Where:

l : length of edge stiffener, in m

σ_{yd} : specified minimum yield stress of the material, in N/mm^2

C : slenderness coefficient

75 for end brackets

50 for tripping brackets

50 for edge reinforcements in way of openings

2.4.3.2 The net thickness of the web plate and flange of the edge stiffener is not to be less than that required in **2.2.1**.

3. Prescriptive Buckling Requirements

3.1 General

3.1.1 Scope

3.1.1.1 This Sub-Section contains the methods for determination of the buckling capacity, definitions of buckling utilisation factors and other measures necessary to control buckling of plate panels, stiffeners and primary support members.

3.1.1.2 The buckling utilisation factor, η , is to satisfy the following criteria:

$$\eta \leq \eta_{allow}$$

Where:

- η_{allow} : allowable buckling utilisation factor as defined in **Section 8** and **Section 9**
 η : buckling utilisation factor, as defined in **3.2.1.1**, **3.3.2.2**, **3.3.3.1**, **3.4.1.1** and **3.5.1.1**

3.1.1.3 For structural idealisation and definitions see also **Section 4/2**. The thickness and section properties of plates and stiffeners are to be taken as specified by the appropriate rule requirements.

3.2 Buckling of Plates

3.2.1 Uni-axial buckling of plates

3.2.1.1 The buckling utilisation factor, η , for uni-axial stress is to be taken as:

$$\eta = \frac{\sigma_x}{\sigma_{xcr}} \quad \text{for compressive stresses in x-direction}$$

$$\eta = \frac{\sigma_y}{\sigma_{ycr}} \quad \text{for compressive stresses in y-direction}$$

$$\eta = \frac{\tau}{\tau_{cr}} \quad \text{for shear stress}$$

Where:

- σ_x, σ_y : actual compressive stresses, in N/mm^2
 τ : actual shear stress, in N/mm^2
 $\sigma_{xcr}, \sigma_{ycr}$: critical compressive stress, in N/mm^2 , as defined in **3.2.1.3**
 τ_{cr} : critical shear stress, in N/mm^2 , as defined in **3.2.1.3**

3.2.1.2 Reference degree of slenderness, to be taken as:

$$\lambda = \sqrt{\frac{\sigma_{yd}}{K \sigma_E}}$$

Where:

- K : buckling factor, see **Table 10.3.1**
 σ_E : reference stress, in N/mm^2
 $= 0.9 E \left(\frac{t_{net}}{l_a} \right)^2$
 E : modulus of elasticity, 206 000 N/mm^2
 t_{net} : net thickness of plate panel, in mm
 l_a : length of the side of the plate panel as defined in **Table 10.3.1**, in mm
 σ_{yd} : specified minimum yield stress of the material, in N/mm^2

3.2.1.3 The critical stresses, σ_{xcr} , σ_{ycr} or τ_{cr} , of plate panels subject to compression or shear, respectively, is to be taken as:

$$\sigma_{xcr} = C_x \sigma_{yd}$$

$$\sigma_{ycr} = C_y \sigma_{yd}$$

$$\tau_{cr} = C_\tau \frac{\sigma_{yd}}{\sqrt{3}}$$

Where:

C_x, C_y, C_τ : reduction factors, as given in **Table 10.3.1**

Table 10.3.1 Buckling Factor and Reduction Factor for Plane Plate Panels

Case	Stress ratio ψ	Aspect ratio α	Buckling factor K	Reduction factor C
1		$\alpha > 1$	$K = \frac{8.4}{\psi + 1.1}$	$C_x = 1$ for $\lambda \leq \lambda_c$
			$K = 7.63 - \psi (6.26 - 10 \psi)$	$C_x = c \left(\frac{1}{\lambda} - \frac{0.22}{\lambda^2} \right)$ for $\lambda > \lambda_c$
			$K = 5.975(1 - \psi)^2$	Where: $c = (1.25 - 0.12\psi) \leq 1.25$ $\lambda_c = \frac{c}{2} \left(1 + \sqrt{1 - \frac{0.88}{c}} \right)$
2		$\alpha \geq 1$	$K = \left(1 + \frac{1}{\alpha^2} \right)^2 \frac{2.1}{(\psi + 1.1)}$	$C_y = c \left(\frac{1}{\lambda} - \frac{R + F^2(H - R)}{\lambda^2} \right)$
		$1 \leq \alpha \leq 1.5$	$K = \left[1 + \frac{1}{\alpha^2} \right]^2 \frac{2.1(1 + \psi)}{1.1} - \frac{\psi}{\alpha^2} (13.9 - 10 \psi)$	Where: $c = (1.25 - 0.12\psi) \leq 1.25$ $R = \lambda(1 - \lambda/c)$ for $\lambda < \lambda_c$ $R = 0.22$ for $\lambda \geq \lambda_c$ $\lambda_c = 0.5c \left(1 + \sqrt{1 - 0.88/c} \right)$ $F = \left(1 - \left(\frac{K}{0.91} - 1 \right) / \lambda_p^2 \right) c_1 \geq 0$ $\lambda_p^2 = \lambda^2 - 0.5$ and $1 \leq \lambda_p^2 \leq 3$ $c_1 = 1$ for σ_y due to direct loads ⁽³⁾ $c_1 = (1 - 1/\alpha) \geq 0$ for σ_y due to bending (in general) ⁽²⁾ $c_1 = 0$ for σ_y due to bending in extreme load cases (e.g. w/t. bhds.)
		$\alpha > 1.5$	$K = \left(\frac{1 - \psi}{\alpha} \right)^2 \frac{2.1(1 + \psi)}{1.1} - \frac{\psi}{\alpha^2} (5.87 + 1.87\alpha^2) + \frac{8.6}{\alpha^2} - 10\psi$	$H = \lambda - \frac{2\lambda}{c(T + \sqrt{T^2 - 4})} \geq R$ $T = \lambda + \frac{14}{15\lambda} + \frac{1}{3}$
	$\psi \leq -1$	$1 \leq \alpha \leq \frac{3(1 - \psi)}{4}$	$K = \left(\frac{1 - \psi}{\alpha} \right)^2 5.975$	
		$\alpha > \frac{3(1 - \psi)}{4}$	$K = \left(\frac{1 - \psi}{\alpha} \right)^2 3.9675 + 0.5375 \left(\frac{1 - \psi}{\alpha} \right)^4 + 1.87$	

Table 10.3.1 (Continued) Buckling Factor and Reduction Factor for Plane Plate Panels

Case	Stress ratio ψ	Aspect ratio α	Buckling factor K	Reduction factor C
3		$\alpha > 0$	$K = \frac{4(0.425 + 1/\alpha^2)}{3\psi + 1}$	$C_x = 1 \quad \text{for } \lambda \leq 0.7$ $C_x = \frac{1}{\lambda^2 + 0.51} \quad \text{for } \lambda > 0.7$
4		$\alpha > 0$	$K = \left(0.425 + \frac{1}{\alpha^2}\right) \frac{3 - \psi}{2}$	
5	-	$\alpha \geq 1$	$K = K_r \sqrt{3}$	
6	-	$0 < \alpha < 1$	$K_r = \left[4 + \frac{5.34}{\alpha^2}\right]$	

Table 10.3.1 (Continued) Buckling Factor and Reduction Factor for Plane Plate Panels

Where:

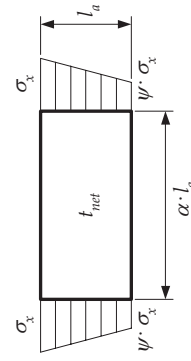
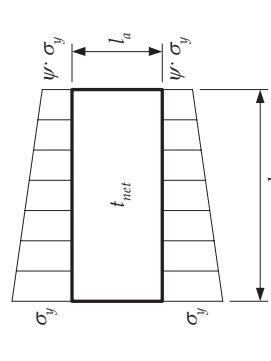
ψ : the ratio between smallest and largest compressive stress as shown for Case 1-4

l_a : length in *mm*, of the shorter side of the plate panel for Cases 1 and 2

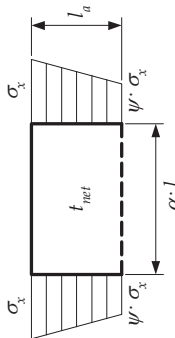
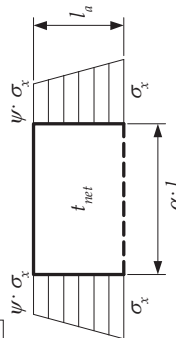
l_a : length in *mm*, of the side of the plate panel as defined for Cases 3, 4, 5 and 6

α : aspect ratio of the plate panel

Edge boundary conditions:

----- plate edge free
 _____ plate edge simply supported

Notes :

(1) Cases listed are general cases. Each stress component (σ_x, σ_y) is to be understood in local coordinates.

(2) c_f due to bending (in general) corresponds to straight edges (uniform displacement) of a plate panel integrated in a large structure.

This value is to be applied for hull girder buckling and buckling of web plate of primary support members in way of openings.

(3) c_f for direct loads corresponds to a plate panel with edges not restrained from pull-in which may result in non-straight edges

3.3 Buckling of Stiffeners

3.3.1 Critical compressive stress

3.3.1.1 The buckling utilisation factor of stiffeners is to be taken as the maximum of the column and torsional buckling mode as given in 3.3.2 and 3.3.3.

3.3.2 Column buckling mode

3.3.2.1 Stiffeners are to be verified against the column buckling mode as given in 3.3.2.2 with the allowable buckling utilisation factor, η_{allow} , see 3.1.1.2. Stiffeners not subjected to lateral pressure and that have a net moment of inertia, I_{net} , complying with 3.3.2.4 have acceptable column buckling strength and need not be verified against 3.3.2.2.

3.3.2.2 The buckling utilisation factor for column buckling of stiffeners is to be taken as:

$$\eta = \frac{\sigma_x + \sigma_b}{\sigma_{yd}}$$

Where:

σ_x : compressive axial stress in the stiffener, in N/mm^2 , in way of the midspan of the stiffener. See Section 3/5.2.3.1

σ_b : bending stress at the midspan of the stiffener according to 3.3.2.3, in N/mm^2

σ_{yd} : specified minimum yield stress of the material, in N/mm^2

3.3.2.3 The bending stress, σ_b , in N/mm^2 , in the stiffener is equal to:

$$\sigma_b = \frac{M_o + M_1}{1000 Z_{net}}$$

Where:

Z_{net} : net section modulus of stiffener, in cm^3 , including effective breadth of plating according to 3.3.4.1

a) if lateral pressure is applied to the stiffener:

Z_{net} is the section modulus calculated at flange if the lateral pressure is applied on the same side as the stiffener.

Z_{net} is the section modulus calculated at attached plate if the lateral pressure is applied on the side opposite to the stiffener.

b) if no lateral pressure is applied on the stiffener:

Z_{net} is the minimum section modulus among those calculated at flange and attached plate.

M_1 : bending moment, in Nmm , due to the lateral load P

$$= \frac{P s l_{stf}^2}{24} 10^3$$

- P : lateral load, in kN/m^2
- s : stiffener spacing as defined in **Section 4/2.2.1**, in mm
- l_{stf} : span of stiffener, in m , equal to spacing between primary support members
- M_0 : bending moment, in Nmm , due to the lateral deformation w of stiffener
 $= F_E \left(\frac{P_z w}{c_f - P_z} \right)$ where $(c_f - P_z) > 0$
- F_E : ideal elastic buckling force of the stiffener, in N
 $= \left(\frac{\pi^2}{l_{stf}^2} \right) E I_{net} 10^{-2}$
- E : modulus of elasticity, 206,000 (N/mm^2)
- I_{net} : moment of inertia, in cm^4 , of the stiffener including effective width of attached plating according to **3.3.4.1**. I_{net} is to comply with the following requirement
 $I_{net} \geq \frac{s t_{net}^3}{12} 10^{-4}$
- t_{net} : net thickness of plate flange, to be taken as the mean thickness of the two attached plate panels, in mm
- P_z : nominal lateral load, in N/mm^2 , acting on the stiffener due to membrane stresses, σ_x , σ_y and τ_1 , in the attached plate in way of the stiffener midspan
 $= \frac{t_{net}}{s} \left(\sigma_{xl} \left(\frac{\pi s}{1000 l_{stf}} \right)^2 + 2 c_y \sigma_y + \sqrt{2} \tau_1 \right)$
- σ_{xl} : $= \sigma_x \left(1 + \frac{A_{net}}{s t_{net}} \right)$ (N/mm^2)
- τ_1 : $= \left[\tau - t_{net} \sqrt{\sigma_{ydl} E \left(\frac{m_1}{(1000 l_{stf})^2} + \frac{m_2}{s^2} \right)} \right] \geq 0$
- with m_1 and m_2 taken equal to
- $m_1 = 1.47 \quad m_2 = 0.49$ for $\frac{1000 l_{stf}}{s} \geq 2.0$
- $m_1 = 1.96 \quad m_2 = 0.37$ for $\frac{1000 l_{stf}}{s} < 2.0$
- σ_x : compressive axial stress in the stiffener, in N/mm^2 , in way of the midspan of the stiffener. See **Section 3/5.2.3.1**
- A_{net} : net sectional area of the stiffener without attached plating, in mm^2
- c_y : factor taking into account the membrane stresses in the attached plating acting perpendicular to the stiffener's axis
 $= 0.5 (1 + \psi)$ for $0 \leq \psi \leq 1$
 $= \frac{0.5}{1 - \psi}$ for $\psi < 0$
- ψ : edge stress ratio for Case 2 according to **Table 10.3.1**
- σ_y : membrane compressive stress in the attached plating acting perpendicular to the stiffener's axis, in N/m^2
- τ : shear membrane stress in the attached plating, in N/mm^2
- σ_{ydl} : specified minimum yield stress of the material, in N/mm^2
- w : deformation of stiffener, in mm
 $= w_0 + w_1$

w_0 : assumed imperfection, in mm .

$$= \min \left[\frac{1000 l_{stf}}{250}, \frac{s}{250}, 10 \right]$$

For stiffeners sniped at both ends w_0 is not to be taken less than the distance from the midpoint of attached plating to the neutral axis of the stiffener calculated with the effective width of the attached plating according to **3.3.4.1**

w_1 : deformation of stiffener at midpoint of stiffener span due to lateral load

P , in mm . In case of uniformly distributed load the w_1 is to be taken as

$$= \frac{P s l_{stf}^4}{384 \cdot E I_{net}} 10^5$$

c_f : elastic support provided by the stiffener, in N/mm^2

$$= F_E \frac{\pi^2}{l_{stf}^2} (1 + c_p) 10^{-6}$$

$$c_p = \frac{1}{1 + \frac{0.91}{c_a} \left(\frac{12 I_{net} 10^4}{s l_{net}^3} - 1 \right)}$$

$$c_a = \left[\frac{1000 l_{stf}}{2s} + \frac{2s}{1000 l_{stf}} \right]^2 \quad \text{for } l_{stf} \geq \frac{2s}{1000}$$

$$c_a = \left[1 + \left(\frac{1000 l_{stf}}{2s} \right)^2 \right]^2 \quad \text{for } l_{stf} < \frac{2s}{1000}$$

3.3.2.4 Stiffeners not subjected to lateral pressure are considered as complying with the requirements of **3.3.2.2** if their net moments of inertia, in cm^4 , satisfy the following requirement:

$$I_{net} \geq 100 \frac{P_z l_{stf}^2}{\pi^2} \left[\frac{w_0 (e_f - 0.5 t_{f-net})}{\eta_{allow} \sigma_{yd} - \sigma_x} + \frac{l_{stf}^2}{E \pi^2} 10^6 \right]$$

Where:

e_f : distance from connection to plate (C as shown in **Fig. 10.3.1**) to centre of flange, in mm

$$= (d_w - 0.5 t_{f-net}) \quad \text{for bulb flats}$$

$$= (d_w + 0.5 t_{f-net}) \quad \text{for angles and T bars}$$

d_w : depth of web plate, in mm , as shown in **Fig. 10.3.1**

t_{f-net} : net flange thickness, in mm

η_{allow} : allowable buckling utilisation factor as defined in **Section 8** and **Section 9**

Note :

Other parameters are as defined in **3.3.2.3**

3.3.3 Torsional buckling mode

3.3.3.1 The torsional buckling mode is to be verified against the allowable buckling utilisation factor, η_{allow} , see

3.1.1.2. The buckling utilisation factor for torsional buckling of stiffeners is to be taken as:

$$\eta = \frac{\sigma_x}{C_T \sigma_{yd}}$$

Where:

σ_x : compressive axial stress in the stiffener, in N/mm^2 , in way of the midspan of the stiffener. See **Section 3/5.2.3.1**

C_T : torsional buckling coefficient

$$= 1.0 \quad \text{for } \lambda_T \leq 0.2$$

$$= \frac{1}{\Phi + \sqrt{\Phi^2 - \lambda_T^2}} \quad \text{for } \lambda_T > 0.2$$

$$\Phi = 0.5(1 + 0.21(\lambda_T - 0.2) + \lambda_T^2)$$

λ_T : reference degree of slenderness for torsional buckling

$$= \sqrt{\frac{\sigma_{yd}}{\sigma_{ET}}}$$

σ_{ET} : reference stress for torsional buckling, in N/mm^2

$$= \frac{E}{I_{p-net}} \left(\frac{\varepsilon \pi^2 I_{\omega-net} 10^{-4}}{l_t^2} + 0.385 I_{T-net} \right)$$

σ_{yd} : specified minimum yield stress of the material, in N/mm^2

E : modulus of elasticity, 206 000 , in N/mm^2

I_{p-net} : net polar moment of inertia of the stiffener about point C, in cm^4 , as shown in **Fig. 10.3.1** and **Table 10.3.2**

I_{T-net} : net St. Venant's moment of inertia of the stiffener, in cm^4 , as shown in **Table 10.3.2**

$I_{\omega-net}$: net sectorial moment of inertia of the stiffener about point C, in cm^6 , as shown in **Fig. 10.3.1** and **Table 10.3.2**

ε : degree of fixation

$$= 1 + 1000 \sqrt{\frac{I_t^4}{\frac{3}{4} \pi^4 I_{\omega-net} \left(\frac{s}{t_{net}^3} + \frac{4(e_f - 0.5t_{f-net})}{3t_{w-net}^3} \right)}}$$

l_t : torsional buckling length to be taken equal the distance between tripping supports, in m

d_w : depth of web plate, in mm

t_{w-net} : net web thickness, in mm

b_f : flange breadth, in mm

t_{f-net} : net flange thickness, in mm

e_f : distance from connection to plate (C in **Fig. 10.3.1**) to centre of flange, in mm

$$= (d_w - 0.5t_{f-net}) \quad \text{for bulb flats}$$

$$= (d_w + 0.5t_{f-net}) \quad \text{for angles and T bars}$$

A_{w-net} : net web area, in mm^2

$$= (e_f - 0.5t_{f-net}) t_{w-net}$$

A_{f-net} : net flange area, in mm^2

$$= b_f t_{f-net}$$

s : stiffener spacing as defined in **Section 4/2.2.1**, in mm

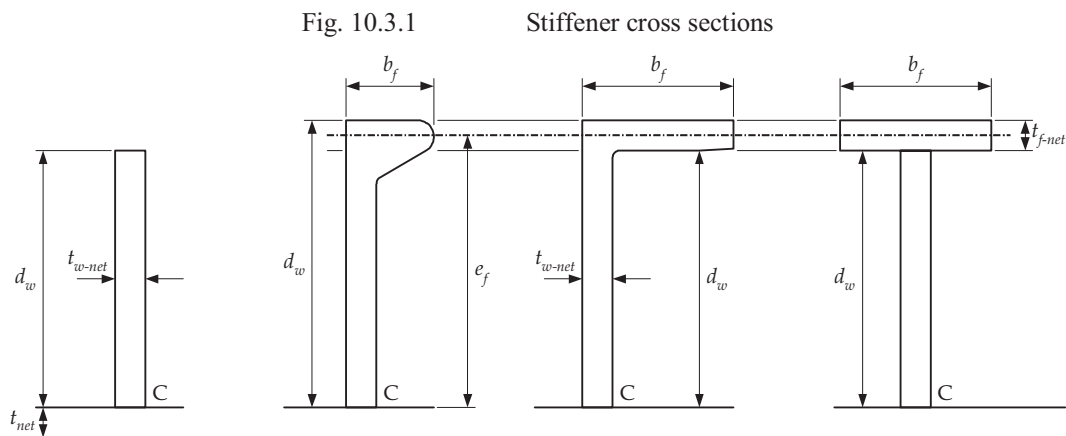

Notes :

1. Measurements of breadth and depth are based on gross scantlings as described in **Section 4/2.4.1.2**.
2. Characteristic flange data for bulb profiles are given in **Appendix C/Table C.1.2**

Table 10.3.2 Moments of Inertia

Section property	Flat bars	Bulb flats, angles and T bars
I_{P-net}	$\frac{d_w^3 t_{w-net}}{3 \times 10^4}$	$\left(\frac{A_{w-net} (e_f - 0.5 t_{f-net})^2}{3} + A_{f-net} e_f^2 \right) 10^{-4}$
I_{T-net}	$\frac{d_w t_{w-net}^3}{3 \times 10^4} \left(1 - 0.63 \frac{t_{w-net}}{d_w} \right)$	$\frac{(e_f - 0.5 t_{f-net}) t_{w-net}^3}{3 \times 10^4} \left(1 - 0.63 \frac{t_{w-net}}{e_f - 0.5 t_{f-net}} \right)$ + $\frac{b_f t_{f-net}^3}{3 \times 10^4} \left(1 - 0.63 \frac{t_{f-net}}{b_f} \right)$
$I_{\omega-net}$	$\frac{d_w^3 t_{w-net}^3}{36 \times 10^6}$	for bulb flats and angles: $\frac{A_{f-net} e_f^2 b_f^2}{12 \times 10^6} \left(\frac{A_{f-net} + 2.6 A_{w-net}}{A_{f-net} + A_{w-net}} \right)$ for T bars: $\frac{b_f^3 t_{f-net} e_f^2}{12 \times 10^6}$

3.3.4 Effective breadth of attached plating

3.3.4.1 The effective breadth of attached plating of ordinary stiffeners is to be taken as:

$$b_{eff} = \min(C_x s, \chi_s s)$$

Where:

$$\chi_s = 0.0035 \left(\frac{1000 l_{eff}}{s} \right)^3 - 0.0673 \left(\frac{1000 l_{eff}}{s} \right)^2 + 0.4422 \left(\frac{1000 l_{eff}}{s} \right) - 0.0056 \leq 1.0$$

s : stiffener spacing as defined in **Section 4/2.2.1**, in mm

C_x : average reduction factor for buckling of the two attached plate panels, according to Case 1 in **Table 10.3.1**

l_{stf} : span of stiffener, in m , equal to spacing between primary support members

l_{eff} : Effective span of stiffeners in m

$l_{eff} = l_{stf}$ if simply supported at both ends

$l_{eff} = 0.6 l_{stf}$ if fixed at both ends

3.4 Primary Support Members

3.4.1 Buckling of web plate of primary support members in way of openings

3.4.1.1 The web plate of primary support members with openings is to be assessed for buckling based on the combined axial compressive and shear stresses. The web plate adjacent to the opening on both sides is to be considered as individual unstiffened plate panels as shown in **Table 10.3.3**. The buckling utilisation factor, η , is to be taken as:

$$\eta = \left(\frac{|\sigma_{av}|}{C \sigma_{yd}} \right)^e + \left(\frac{|\tau_{av}| \sqrt{3}}{C_\tau \sigma_{yd}} \right)^{e_\tau}$$

Where:

σ_{av} : average compressive stress in the area of web plate being considered according to case 1, 2 or 3 in **Table 10.3.1**, in N/mm^2

τ_{av} : average shear stress in the area of web plate being considered according to case 5 or 6 in **Table 10.3.1**, in N/mm^2

σ_{yd} : specified minimum yield stress of the material, in N/mm^2



$e = 1 + C^4$: exponent for compressive stress

$e_\tau = 1 + C C_\tau^2$: exponent for shear stress

- $C = C_x$: reduction factor according to Case 1 or 3, **Table 10.3.1**
- $C = C_y$: reduction factor according to Case 2, **Table 10.3.1**
- C_τ : reduction factor according to Case 5 or 6, **Table 10.3.1**

3.4.1.2 The reduction factors, C_x or C_y in combination with C_τ , of the plate panel(s) of the web adjacent to the opening is to be taken as shown in **Table 10.3.3**.

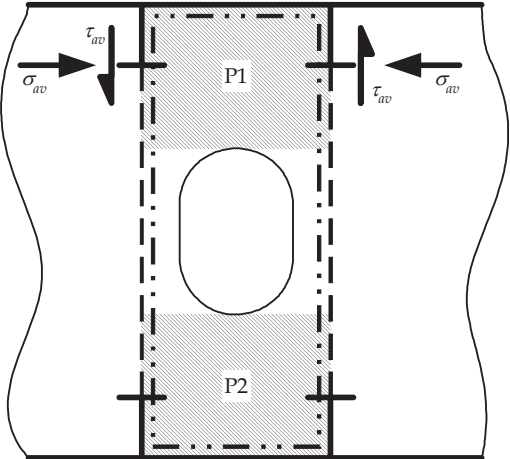
Table 10.3.3 Reduction Factors

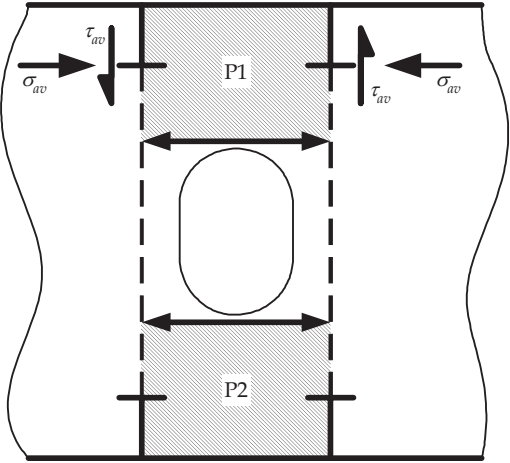
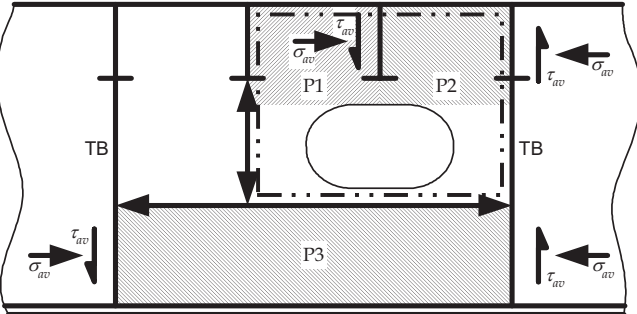
Mode	C_x, C_y	C_τ
<p>(a) without edge reinforcements</p> 	<p>Separate reduction factors are to be applied to areas P1 and P2 using Case 3, Table 10.3.1, with edge stress ratio: $\psi = 1.0$</p>	<p>A common reduction factor is to be applied to areas P1 and P2 using Case 6, Table 10.3.1 for area marked:</p> 
<p>(b) with edge reinforcements</p> 	<p>Separate reduction factors are to be applied for areas P1 and P2 using: C_x for Case 1 or C_y, for Case 2, see Table 10.3.1 with stress ratio $\psi = 1.0$</p>	<p>Separate reduction factors are to be applied for areas P1 and P2 using Case 5, Table 10.3.1</p>
<p>(c) example of hole in web</p> 	<p>Panels P1 and P2 are to be evaluated in accordance with (a). Panel P3 is to be evaluated in accordance with (b)</p>	

Note :

1. Web panels to be considered for buckling in way of openings are shown shaded and numbered P1, P2, etc.

3.5 Other Structures

3.5.1 Struts, pillars and cross ties

3.5.1.1 The critical buckling stress for axially compressed struts, pillars and cross ties is to be taken as the lesser of the column and torsional critical buckling stresses. The buckling utilisation factor, η , is to be taken as:

$$\eta = \frac{\sigma_{av}}{\sigma_{cr}}$$

Where:

σ_{av} : average axial compressive stress in the member, in N/mm^2

σ_{cr} : minimum critical buckling stress according to **3.5.1.2**, in N/mm^2

3.5.1.2 The critical buckling stress in compression, σ_{cr} , for each mode is to be taken as:

$$\sigma_{cr} = \sigma_E \quad \text{for } \sigma_E \leq 0.5\sigma_{yd}$$

$$\sigma_{cr} = \left(1 - \frac{\sigma_{yd}}{4\sigma_E}\right)\sigma_{yd} \quad \text{for } \sigma_E > 0.5\sigma_{yd}$$

Where:

σ_E : elastic compressive buckling stress, in N/mm^2 , given for each buckling mode, see **3.5.1.3** to **3.5.1.5**

σ_{yd} : specified minimum yield stress of the material, in N/mm^2

3.5.1.3 The elastic compressive column buckling stress, σ_E , of pillars subject to axial compression is to be taken as:

$$\sigma_E = 0.001E f_{end} \frac{I_{net50}}{A_{pill-net50} l_{pill}^2} \quad (N/mm^2)$$

Where:

I_{net50} : net moment of inertia about the weakest axis of the cross-section, in cm^4

$A_{pill-net50}$: net cross-sectional area of the pillar, in cm^2

f_{end} : end constraint factor

1.0 where both ends are pinned

2.0 where one end is pinned and the other end is fixed

4.0 where both ends are fixed

A pillar end may be considered fixed when effective brackets are fitted. These brackets are to be supported by structural members with greater bending stiffness than the pillar.

Column buckling capacity for cross tie shall be calculated using f_{end} equal to 2.0 and span as defined in **Section 8/2.6.8.1**.

E : modulus of elasticity, 206 000, in N/mm^2

l_{pill} : unsupported length of the pillar, in m

3.5.1.4 The elastic torsional buckling stress, σ_{ET} , with respect to axial compression of pillars is to be taken as:

$$\sigma_{ET} = \frac{GI_{sv-net50}}{I_{pol-net50}} + \frac{0.001f_{end}Ec_{warp}}{I_{pol-net50}l_{pill}^2} \quad (N/mm^2)$$

Where:

G : shear modulus

$$= \frac{E}{2(1+\nu)}$$

E : modulus of elasticity, 206 000, in N/mm^2

ν : Poisson's ratio, 0.3

$I_{sv-net50}$: net St. Venants moment of inertia, in cm^4 , see **Table 10.3.4**

$I_{pol-net50}$: net polar moment of inertia about the shear centre of cross section, in cm^4
 $= I_{y-net50} + I_{z-net50} + A_{net50}(y_0^2 + z_0^2)$

f_{end} : end constraint factor

1.0 where both ends are pinned

2.0 where one end is pinned and the other end is fixed

4.0 where both ends are fixed

Elastic torsional buckling capacity for cross tie shall be calculated using f_{end} equal to 2.0 and span as defined in **Section 8/2.6.8.1**.

- c_{warp} : warping constant, in cm^6 , see **Table 10.3.4**
- l_{pill} : unsupported length of the pillar, in m
- y_0 : position of shear centre relative to the cross-sectional centroid, in cm , see **Table 10.3.4**
- z_0 : position of shear centre relative to the cross-sectional centroid, in cm , see **Table 10.3.4**
- A_{net50} : net cross-sectional area, in cm^2
- $I_{y-net50}$: net moment of inertia about y-axis, in cm^4
- $I_{z-net50}$: net moment of inertia about z-axis, in cm^4

3.5.1.5 For cross-sections where the centroid and the shear centre do not coincide, the interaction between the torsional and column buckling mode is to be examined. The elastic torsional/column buckling stress, σ_{ETF} , with respect to axial compression is to be taken as:

$$\sigma_{ETF} = \frac{1}{2\zeta} \left[(\sigma_E + \sigma_{ET}) - \sqrt{(\sigma_E + \sigma_{ET})^2 - 4\zeta\sigma_E\sigma_{ET}} \right]$$

Where:

$$\zeta = 1 - \frac{(y_0^2 + z_0^2)A_{net50}}{I_{pol-net50}}$$

- y_0 : position of shear centre relative to the cross-sectional centroid, in cm , see **Table 10.3.4**
- z_0 : position of shear centre relative to the cross-sectional centroid, in cm , see **Table 10.3.4**
- A_{net50} : net cross-sectional area, in cm^2
- $I_{pol-net50}$: net polar moment of inertia about the shear centre of cross section, as defined in **3.5.1.4**
- σ_{ET} : elastic torsional buckling stress, as defined in **3.5.1.4**
- σ_E : elastic column compressive buckling stress, as defined in **3.5.1.3**

Table 10.3.4 Cross Sectional Properties

double symmetrical sections	
	$I_{sv-net50} = \frac{1}{3} (2b_f t_f^3 + d_{wt} t_w^3) 10^{-4} \quad (cm^4)$
	$c_{warp} = \frac{d_{wt}^2 b_f^3 t_f}{24} 10^{-6} \quad (cm^6)$

Table 10.3.4 (Continued) Cross Sectional Properties

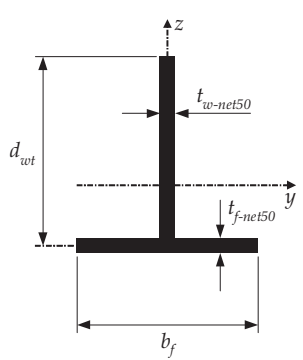
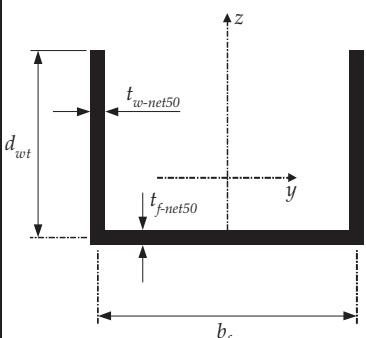
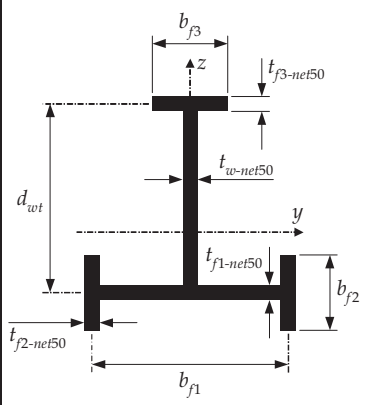
single symmetrical sections	
	$I_{sv-net50} = \frac{1}{3} (b_f t_{f-net50}^3 + d_{wt} t_{w-net50}^3) 10^{-4} \quad (cm^4)$ $y_0 = 0 \text{ cm}$ $z_0 = - \frac{0.5 d_{wt}^2 t_{w-net50}}{d_{wt} t_{w-net50} + b_f t_{f-net50}} 10^{-1} \quad (cm)$ $c_{warp} = \frac{b_f^3 t_{f-net50}^3 + 4 d_{wt}^3 t_{w-net50}^3}{144} 10^{-6} \quad (cm^6)$
	$I_{sv-net50} = \frac{1}{3} (b_{fu} t_{f-net50}^3 + 2 d_{wt} t_{w-net50}^3) 10^{-4} \quad (cm^4)$ $y_0 = 0 \text{ cm}$ $z_0 = - \frac{d_{wt}^2 t_{w-net50} 10^{-1}}{2 d_{wt} t_{w-net50} + b_{fu} t_{f-net50}} - \frac{0.5 d_{wt}^2 t_{w-net50} 10^{-1}}{d_{wt} t_{w-net50} + b_{fu} t_{f-net50} / 6} \quad (cm)$ $c_{warp} = \frac{b_{fu}^2 d_{wt}^3 t_{w-net50} (3 d_{wt} t_{w-net50} + 2 b_{fu} t_{f-net50})}{12 (6 d_{wt} t_{w-net50} + b_{fu} t_{f-net50})} 10^{-6} \quad (cm^6)$
	$I_{sv-net50} = \frac{1}{3} (b_{f1} t_{f1-net50}^3 + 2 b_{f2} t_{f2-net50}^3 + b_{f3} t_{f3-net50}^3 + d_{wt} t_{w-net50}^3) 10^{-4} \quad (cm^4)$ $y_0 = 0 \text{ cm}$ $z_0 = z_s - \frac{(b_{f3} d_{wt} t_{f3-net50} + 0.5 d_{wt}^2 t_{w-net50}) 10^{-1}}{d_{wt} t_{w-net50} + b_{f1} t_{f1-net50} + 2 b_{f2} t_{f2-net50} + b_{f3} t_{f3-net50}} \quad (cm)$ $c_{warp} = I_{f1} z_s^2 + \frac{I_{f2} b_{f1}^2}{200} + I_{f3} \left(\frac{d_{wt}}{10} - z_s \right)^2 \quad (cm^6)$ $I_{f1} = \left(\frac{b_{f1} - t_{f2-net50}}{12} t_{f1-net50}^3 + \frac{b_{f2} t_{f2-net50} b_{f1}^2}{2} \right) 10^{-4} \quad (cm^4)$ $I_{f2} = \frac{b_{f2}^3 t_{f2-net50}}{12} 10^{-4} \quad (cm^4)$ $I_{f3} = \frac{b_{f3}^3 t_{f3-net50}}{12} 10^{-4} \quad (cm^4)$ $z_s = \frac{I_{f3} d_{wt}}{I_{f1} + I_{f3}} 10^{-1} \quad (cm)$

Note :

1. All dimensions of thickness, breadth and depth are in *mm*
2. Cross sectional properties not covered by this table are to be obtained by direct calculation.

3.5.2 Corrugated bulkheads

3.5.2.1 Local buckling of a unit flange of corrugated bulkheads is to be controlled according to 3.2.1.1, for Case 1, as shown in Table 10.3.1, applying stress ratio $\psi = 1.0$.

3.5.2.2 The overall buckling failure mode of corrugated bulkheads subjected to axial compression is to be checked for column buckling according to 3.5.1 (e.g. horizontally corrugated longitudinal bulkheads, vertically corrugated bulkheads subject to localised vertical forces). End constraint factor corresponding to pinned ends is to be applied except for fixed end support to be used in way of stool with width exceeding 2 times the depth of the corrugation.

4. Advanced Buckling Analyses

4.1 General

4.1.1 Assessment

4.1.1.1 For the assessment of buckling of plates and stiffened panels subjected to combined stress fields, the advanced buckling assessment method is to be followed.

4.1.1.2 The advanced buckling assessment method is to consider the following effects in deriving the buckling capacity:

- (a) non linear geometrical behaviour
- (b) inelastic material behaviour
- (c) initial imperfections (geometrical out-of flatness of plate and stiffeners)
- (d) welding residual stresses
- (e) interactions between structural elements; plates, stiffeners, girders etc.
- (f) simultaneous acting loads; bi-axial compression/tension, shear and lateral pressure
- (g) boundary conditions

4.1.1.3 All effects are to be modelled to represent a lower bound of structural strength. The modelling shape and amplitude of geometrical imperfections is to be such that they trigger the most critical failure modes.

4.1.1.4 The buckling strength is to be derived in accordance with the method described in **Appendix D**.

4.1.1.5 Alternative advanced buckling analysis tools may be used provided they give comparable results with the bench mark results obtained from implementing the advanced buckling methodology described in **Appendix D**.

4.1.1.6 Theoretical background, assumptions, models, verifications, calibrations, etc., for alternative advanced buckling analysis are to be submitted for review and acceptance.

Section 11 GENERAL REQUIREMENTS

1. Hull Openings and Closing Arrangements

1.1 Shell and Deck Openings

1.1.1 General

1.1.1.1 For closing appliances for openings in superstructures, deck house sides and ends see **1.4**. For overflows and vents, and for discharges and inlets, see **1.5**.

1.1.1.2 For testing requirements, see **Sub-Section 5**.

1.1.2 Cargo tank hatches - materials

1.1.2.1 Covers for access hatches, tank cleaning and other openings for cargo tanks and adjacent spaces are to be manufactured from the following material:

- (a) normal strength steel in accordance with **Section 6/1**
- (b) non-ferrous material such as bronze or brass may be considered; however, aluminium alloy is not to be used for covers of any opening to cargo tanks and spaces adjacent thereto
- (c) synthetic materials may also be considered, taking into account their fire resistance and physical and chemical properties in relation to the intended operating conditions. Details of the properties of the material, the design of the cover, and the method of manufacture are to be submitted for approval.

1.1.2.2 The hatch cover packing material is to be compatible with the cargoes that are intended to be carried and is to be effectively held in place.

1.1.3 Cargo tank access coamings

1.1.3.1 The height of the hatch coaming above the upper surface of the freeboard deck is not to be less than 600mm. Lower heights may be permitted by the Flag Administration. The top of the hatch coaming is also not to be lower than the highest point of the tank over which it is fitted and is to be of sufficient height for the purpose of damage stability.

1.1.3.2 The gross thickness of the coaming plate is not to be less than 10mm. Where the coaming height, as fitted, exceeds 600mm, the thickness may be required to be increased or edge stiffening fitted. The scantlings of coaming plates of tank access coamings that enclose an area of 1.2m² or more, and/or those that are not configured with a well rounded shape, may be subject to additional requirements.

1.1.4 Cargo tank access hatch covers

1.1.4.1 The gross thickness of unstiffened plate covers with an area less than 1.2m² is not to be less than 12.5mm. The gross thickness of covers of a larger area will need to be increased or the cover will require stiffening.

1.1.4.2 Flat and unstiffened covers on circular hatchways are to be secured by fastenings with a spacing of not more than 600mm.

1.1.4.3 On rectangular hatchways, the spacing of fastenings is generally not to be greater than 450mm and the distance between hatch corners, and adjacent fastenings, is not to be greater than 230mm.

1.1.4.4 The requirements of **1.1.4.1** to **1.1.4.3** do not apply to dished covers or covers of other specially approved design.

1.1.4.5 Where the cover is hinged, adequate stiffening of the coaming and cover in way of the hinge is to be provided. In general, hinges are not to be considered securing devices for the cover and should be designed so as to prevent the gasket from being over tightened.

1.1.5 Machinery access openings - protection

1.1.5.1 Machinery casings are generally to be protected by an enclosed poop or bridge; or by a deck house structure complying with the strength requirements of **1.4**.

1.1.5.2 Where a vessel is intended to operate at the freeboard allowed by the *International Convention on Load Lines* for Type-A freeboard vessels, the height of such structure is not to be less than 2.3m. The bulkheads at the forward

ends of these structures are to have scantlings at least equivalent to those required for bridge-front bulkheads, see **1.4.9** and **1.4.13**.

1.1.6 Small hatches on the exposed fore deck

1.1.6.1 Openings to forward spaces as defined in **1.1.6.2** are to comply with the requirements of **1.1.6.3** to **1.1.6.14**.

1.1.6.2 These requirements apply to small hatches (generally openings $2.5m^2$ or less) on the exposed deck within $0.25L_{CSR-T}$ from the F.P. and at a height less than $0.1L_{CSR-T}$ or $22m$, whichever is less, from the summer load water line at the location of the hatch.

1.1.6.3 Hatches designed for emergency escape need not comply with **1.1.6.9(a)**, **1.1.6.9(b)**, **1.1.6.13** and **1.1.6.14**.

1.1.6.4 For small rectangular steel hatch covers, the plate thickness, stiffener arrangement and scantlings are to be in accordance with **Table 11.1.1** and **Fig. 11.1.1**.

1.1.6.5 Stiffeners, where fitted, are to be aligned with the metal to metal contact points required by **1.1.6.10** and **1.1.6.11**. See also **Fig. 11.1.1**. Primary stiffeners are to be continuous. All stiffeners are to be welded to the inner edge stiffener. See **Fig. 11.1.2**.

1.1.6.6 The upper edge of the hatchway coaming is to be suitably reinforced by a horizontal member, normally not more than $190mm$ from the upper edge of the coaming.

1.1.6.7 For small hatch covers of circular or similar shape, the cover plate thickness and reinforcement is to provide strength and stiffness equivalent to the requirements for small rectangular hatches.

1.1.6.8 For small hatch covers constructed of materials other than normal strength steel, the required scantlings are to provide equivalent strength and stiffness.

1.1.6.9 The primary securing devices are to be such that the hatch cover can be secured in place and be made weathertight by means of a closing mechanism employing any one of the following methods:

- (a) butterfly nuts tightening onto forks (clamps)
- (b) quick acting cleats, or
- (c) a central locking device.

Dogs (twist tightening handles) with wedges are not acceptable.

1.1.6.10 The hatch cover is to be fitted with a gasket of elastic material. This is to be designed to allow a metal to metal contact at a designed compression and to prevent over compression of the gasket by green sea forces that may cause the securing devices to be loosened or dislodged.

1.1.6.11 The metal to metal contacts are to be arranged close to each securing device as shown in **Fig. 11.1.1**, and are to be of sufficient capacity to withstand the bearing force.

1.1.6.12 The primary securing method is to be designed and manufactured such that the designed compression pressure can be achieved by one person without the need for any tools.

1.1.6.13 For a primary securing method using butterfly nuts, the forks (clamps) are to be of robust design. They are to be designed to minimize the risk of butterfly nuts being dislodged while in use, by means of curving the forks upward and raising the surface on the free end, or a similar method. The gross plate thickness of unstiffened steel forks is not to be less than $16mm$. An example arrangement is shown in **Fig. 11.1.2**.

1.1.6.14 Small hatches on the exposed fore deck are to be fitted with an independent secondary securing device, e.g. by means of a sliding bolt, a hasp or a backing bar of slack fit, which is capable of keeping the hatch cover in place, even in the event that the primary securing device becomes loosened or dislodged. It is to be fitted on the side opposite to the hatch cover hinges.

1.1.6.15 For small hatch covers located on the exposed deck within the forward $0.25L_{CSR-T}$ from the F.P., the hinges are to be fitted such that the predominant direction of green sea will cause the cover to close, which means that the hinges are normally to be located on the fore edge.

Table 11.1.1 Scantlings for Small Steel Hatch Covers on the Fore Deck

Nominal Size (mm × mm)	Cover Plate Gross Thickness (mm)	Primary Stiffeners	Secondary Stiffeners
		Gross Flat Bar Scantlings (mm × mm); number	
630 × 630	8	---	---
630 × 830	8	100 × 8; 1	---
830 × 630	8	100 × 8; 1	---
830 × 830	8	100 × 10; 1	---
1030 × 1030	8	120 × 12; 1	80 × 8; 2
1330 × 1330	8	150 × 12; 2	100 × 10; 2

Fig. 11.1.1 Arrangement of Stiffeners

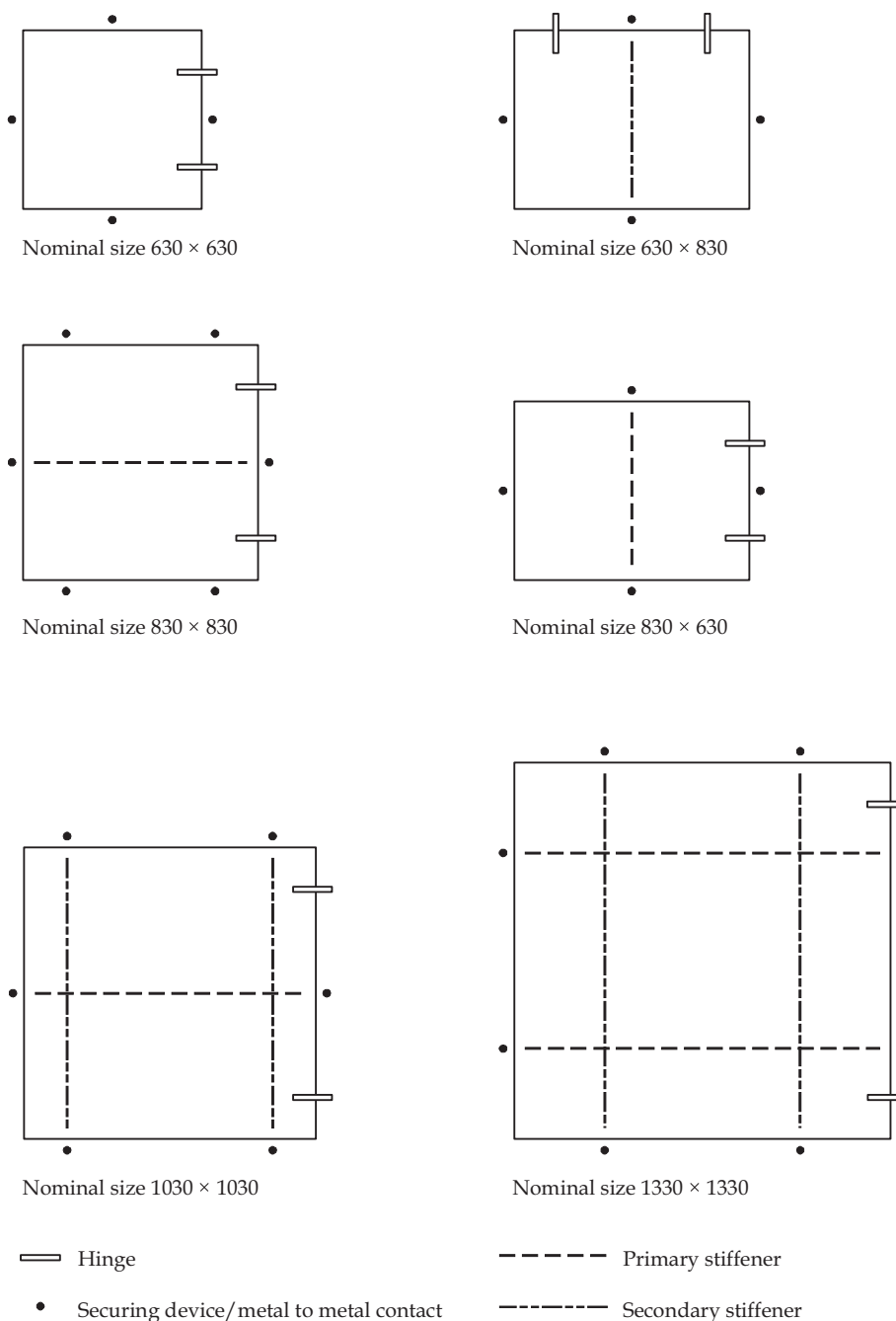

Note :

1. Size dimensions are in millimetres

Fig. 11.1.2 Example of a Primary Securing Method

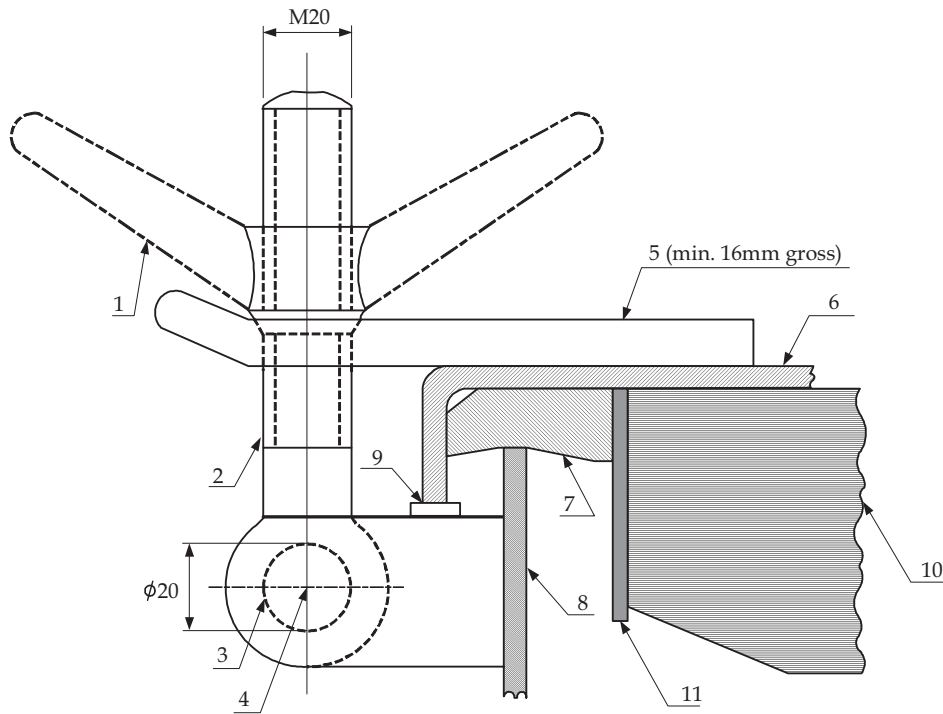

(Note: Dimensions in millimeters)

- 1: butterfly nut
- 2: bolt
- 3: pin
- 4: center of pin
- 5: fork (clamp) plate
- 6: hatch cover
- 7: gasket
- 8: hatch coaming
- 9: bearing pad welded on the bracket of a toggle bolt for metal to metal contact
- 10: stiffener
- 11: inner edge stiffener

1.1.7 Manholes and flush deck scuttles

1.1.7.1 Manholes and flush deck scuttles in Position 1 or Position 2, as defined in **Section 4/1.2**, or within superstructures, other than enclosed superstructures, are to be closed by substantial covers capable of being made watertight.

1.1.7.2 The strength of watertight manholes is to be equivalent to that of the deck.

1.1.7.3 Unless secured by closely spaced bolts, the covers are to be permanently attached.

1.1.8 Other openings

1.1.8.1 Openings in freeboard decks other than hatchways, machinery space openings, manholes and flush scuttles are to be protected by an enclosed superstructure, or by a deck house or companionway of equivalent strength and weathertightness. Any such opening in an exposed superstructure deck, or in the top of a deck house on the freeboard deck, which gives access to a space below the freeboard deck or a space within an enclosed superstructure, is to be protected by an efficient deck house or companionway, as defined in **1.4**.

1.1.9 Escape openings

1.1.9.1 The closing appliances of escape openings are to be readily operable from each side.

1.1.10 Rope hatches

1.1.10.1 Rope hatches may be accepted with reduced coaming height, but generally not less than 380mm, provided that they are well secured and can be opened only at the Master's discretion. The gross thickness of the coaming is to be not less than the Rule minimum gross thickness for hull envelope plating for that position, or 11mm, whichever is the lesser.

1.1.11 Portable plates

1.1.11.1 Where portable plates are required in casings or decks, for unshipping machinery or other similar reasons, they may be accepted provided that they are of equivalent strength to the un-pierced bulkhead or deck. Portable plates may be fitted with flush covers and they are to be secured by gaskets and closely spaced bolts at a distance not greater than five bolt diameters.

1.1.11.2 The sill heights of access openings and the coaming heights of deck openings, closed by covers which are kept permanently closed at sea will be specially considered.

1.1.12 Tank cleaning and ullage openings

1.1.12.1 Tank cleaning and ullage openings are to be fitted with watertight covers or an equivalent. Flush covers may be accepted for tank cleaning and ullage openings where they comply with the applicable requirements of **1.1.11**.

Table 11.1.2 900mm High Ventilator Thickness and Bracket Standards

Nominal pipe Size	Minimum fitted gross thickness, in <i>mm</i>	Maximum projected area of head, in <i>cm²</i>	Height of brackets, in <i>mm</i>
80A	6.3	-	460
100A	7.0	-	380
150A	8.5	-	300
200A	8.5	550	-
250A	8.5	880	-
300A	8.5	1200	-
350A	8.5	2000	-
400A	8.5	2700	-
450A	8.5	3300	-
500A	8.5	4000	-

1.2 Ventilators**1.2.1 General**

1.2.1.1 Ventilators are to comply with the requirements of **1.2.2** through **1.2.6** and are also to be in accordance with any relevant requirements for machinery of the individual Classification Societies.

1.2.2 Details, arrangements and scantlings for ventilators

1.2.2.1 For standard ventilators of 900mm in height, closed by heads of not more than the tabulated projected area, the minimum pipe thickness and bracket heights are to be as specified in **Table 11.1.2**.

1.2.2.2 For ventilators of height greater than 900mm, brackets or alternative means of support are to be provided. Brackets, where fitted, are to be of suitable thickness and length according to their height.

1.2.2.3 Ventilators are to have coamings constructed of steel or other equivalent material and are to meet the requirements indicated in **Table 11.1.3**.

1.2.2.4 All component parts and connections of ventilators are to be capable of withstanding the loads defined in **1.2.3**.

1.2.2.5 Rotating type mushroom ventilator heads are not to be used for application in the areas specified in **1.2.3.1**.

1.2.2.6 Ventilators passing through superstructures, other than enclosed superstructures, are to have substantially constructed coamings of steel or other equivalent material at the freeboard deck. Ventilators of deep tanks or tunnels passing through tween decks are to be watertight with scantlings to withstand the expected pressure.

Table 11.1.3 Coamings for Ventilators

Feature	Requirement
Height ⁽⁴⁾	$h_{coam} = 900$ at Position 1 $h_{coam} = 760$ at Position 2 ⁽¹⁾
Thickness ^{(2), (3)}	$d_{coam} \leq 130$ $t_{coam-grs} = 7.5$ $165 < d_{coam} < 320$ $t_{coam-grs} = 8.5$ $d_{coam} \geq 470$ $t_{coam-grs} = 10.0$ Intermediate values are to be obtained by linear interpolations
Support ⁽³⁾	Where h_{coam} exceeds 900 the coaming is to be specially supported

Where:

- h_{coam} : height of coaming, in *mm*
- d_{coam} : external diameter of coaming, in *mm*
- $t_{coam-grs}$: gross thickness of coaming, in *mm*

Note :

1. The coaming height may need to be increased to satisfy any applicable subdivision and damage stability requirements.
2. Where the height of the ventilator exceeds that given, the gross thickness given above may be gradually reduced, above that height, to a minimum of 6.5*mm*.
3. See also 1.2.3 and for 1.2.4 ventilators in the forward part of the ship.
4. Heights are measured above sheathing, if fitted.

1.2.3 Applied loading on ventilators

1.2.3.1 Ventilators on an exposed deck within the forward $0.25L_{CSR-T}$, and where the height of the exposed deck at the ventilator is less than $0.1L_{CSR-T}$ or 22*m*, whichever is less, from the summer load waterline are to comply with the requirements of 1.2.3.2 through 1.2.3.3 and 1.2.4.1.

1.2.3.2 The pressures acting on ventilators, P_{vent} , and their closing devices are given by:

$$P_{vent} = 0.5\rho_{sw}v_{sea}^2 C_1 C_2 C_3 \quad (kN/m^2)$$

Where:

- ρ_{sw} : density of sea water, 1.025 *tonnes/m³*
- v_{sea} : velocity of water over the fore deck, 13.5 *m/sec*
- C_1 : shape coefficient:
 - 0.5 for pipes
 - 1.3 for pipe or ventilator heads in general
 - 0.8 for pipe or ventilator heads of cylindrical form with its axis in the vertical direction
- C_2 : slamming coefficient, 3.2
- C_3 : protection coefficient:
 - 0.7 for pipes and ventilator heads located immediately behind a breakwater or forecastle
 - 1.0 elsewhere, including immediately behind a bulwark

1.2.3.3 Forces acting in the horizontal direction on the ventilator and its closing device may be calculated from the above pressure, using the largest projected area of each component.

1.2.4 Strength requirements for ventilators and their closing devices

1.2.4.1 Bending moments and stresses in ventilators are to be calculated at critical positions:

- (a) at penetration pieces
- (b) at weld or flange connections
- (c) at toes of supporting brackets.

Bending stresses in the net section are not to exceed $0.8\sigma_{yd}$, where σ_{yd} is the specified minimum yield stress or 0.2% proof stress of the steel at room temperature. Irrespective of corrosion protection, a corrosion addition to the net section of 2*mm* is then to be applied.

1.2.5 Closing appliances

1.2.5.1 Except as indicated otherwise in this paragraph, ventilator openings are to be provided with efficient, permanently attached, closing appliances. Ventilators in Position 1, the coamings of which extend to more than 4.5*m*

above the deck, and in Position 2, the coamings of which extend to more than 2.3m above the deck, need not be fitted with closing arrangements unless unusual features of the design make it necessary. Position 1 and Position 2 are defined in **Section 4/1.2**.

1.2.6 Fire dampers

1.2.6.1 Where a fire damper is located within a ventilation coaming, an inspection port or opening at least 150mm in diameter is to be provided in the coaming to facilitate survey of the damper without disassembling the coaming or the ventilator. The closure provided for the inspection port or opening is to maintain the weathertight integrity of the coaming and, if appropriate, the fire integrity of the coaming.

1.3 Air Pipes

1.3.1 General

1.3.1.1 Air pipes are to comply with the requirements of **1.3.2** through **1.3.6** and are also to be in accordance with any relevant requirements for machinery of the individual Classification Societies.

1.3.2 Height

1.3.2.1 The minimum height for air pipes on decks exposed to weather is given as:

- (a) 760mm for those on the freeboard deck; and
- (b) 450mm for those on the superstructure deck.

The height is to be measured from the top of the sheathing, if fitted, to the point where water may have access below.

1.3.2.2 Where these heights may interfere with the working of the vessel, a lower height may be accepted subject to the fitting of an approved closing appliance at the open end of the vent.

1.3.2.3 The height may need to be increased to satisfy any applicable subdivision and damage stability requirements.

1.3.2.4 Where air pipes are led through the side of superstructures, the height of their opening is to be at least 2.3m above the summer load waterline. Automatic vent heads of approved design are to be provided.

1.3.3 Details, arrangement and scantlings for air pipes

1.3.3.1 The wall thicknesses of air pipes, where exposed to weather, are not to be taken less than that given in **Table 11.1.4**.

Table 11.1.4 Minimum wall Thickness for Air Pipes

External diameter, in mm	Gross minimum wall thickness, in mm
$d_{air} \leq 80$	6.0
$d_{air} \geq 165$	8.5

Where:

d_{air} : external diameter of pipe, in mm

Note :

Intermediate values are to be obtained by linear interpolations.

See also **1.3.4** and **1.3.5** for ventilators in forward part of the ship.

1.3.3.2 For standard air pipes of 760mm in height, closed by heads of not more than the tabulated projected area, the minimum pipe thickness and bracket heights are to be as specified in **Table 11.1.5**. Where brackets are required, three or more radial brackets are to be fitted. In addition, the relevant requirements of **1.3.4** are to be applied.

1.3.3.3 Brackets are to have a gross thickness of 8mm or more, minimum length of 100mm, and height according to **Table 11.1.5**, but need not extend over the joint flange for the head. Bracket toes at the deck are to be suitably supported. In addition, loads according to **1.3.4** are to be applied. Brackets, where fitted, are to be of suitable thickness and length according to their height.

1.3.3.4 Gross pipe thickness is to be in accordance with the relevant requirements for machinery of the individual Classification Societies.

1.3.4 Applied loading on air pipes

1.3.4.1 Air pipes on an exposed deck within the forward $0.25L_{CSR-T}$, where the height of the exposed deck at the air pipe is less than $0.1L_{CSR-T}$ or 22m, whichever is less, from the summer load waterline are to comply with the requirements of **1.3.4.2** through **1.3.4.3** and **1.3.5.1**.

Table 11.1.5 Thickness and Bracket Standards for 760mm High Air Pipes

Nominal pipe size	Minimum fitted gross thickness, in mm	Maximum projected area of head, in cm ²	Height ⁽¹⁾ of brackets, in mm
65A	6.0	-	480
80A	6.3	-	460
100A	7.0	-	380
125A	7.8	-	300
150A	8.5	-	300
175A	8.5	-	300
200A	8.5 ⁽²⁾	1900	300 ⁽²⁾
250A	8.5 ⁽²⁾	2500	300 ⁽²⁾
300A	8.5 ⁽²⁾	3200	300 ⁽²⁾
350A	8.5 ⁽²⁾	3800	300 ⁽²⁾
400A	8.5 ⁽²⁾	4500	300 ⁽²⁾

Note

- : Brackets (see 1.3.3.2) need not extend over the joint flange for the head.
- : Brackets are required where the gross thickness of the pipe section is less than 10.5mm, or where the tabulated projected head area is exceeded.

1.3.4.2 The pressures acting on air pipes and their closing devices, P_{pipe} , are given by:

$$P_{pipe} = 0.5\rho_{sw}v_{sea}^2C_1C_2C_3 \quad (kN/m^2)$$

Where:

- ρ_{sw} : density of sea water, 1.025 tonnes/m³
- v_{sea} : velocity of water over the fore deck, 13.5 m/sec
- C_1 : shape coefficient:
 - 0.5 for pipes
 - 1.3 for pipe or ventilator heads in general
 - 0.8 for pipe or ventilator heads of cylindrical form with its axis in the vertical direction
- C_2 : slamming coefficient, **3.2**
- C_3 : protection coefficient:
 - 0.7 for pipes and ventilator heads located immediately behind a breakwater or forecastle
 - 1.0 elsewhere, including immediately behind a bulwark

1.3.4.3 Forces acting in the horizontal direction on the pipe and its closing device may be calculated from the above pressure, using the largest projected area of each component.

1.3.5 Strength requirements for air pipes and their closing devices

1.3.5.1 Bending moments and stresses in air pipes are to be calculated at critical positions:

- (a) at penetration pieces
- (b) at weld or flange connections
- (c) at toes of supporting brackets.

Bending stresses in the net section are not to exceed 0.8 σ_{yd} , where σ_{yd} is the specified minimum yield stress or 0.2% proof stress of the steel at room temperature. Irrespective of corrosion protection, a corrosion addition to the net section of 2mm is then to be applied.

1.3.6 Closing appliances for air pipes

1.3.6.1 All air pipes terminating on the weather deck are to be fitted with return bends (gooseneck), or other equivalent arrangement to prevent water from passing inboard.

1.3.6.2 A weathertight permanent means of closure is to be provided for the outlet. The closing device is to be of an automatic type, i.e. close automatically upon submergence (e.g. ball float or equivalent) for any one of the following cases:

- (a) the outlet is submerged, with the ship at its summer load water line at an angle of 40 *degrees*, or the angle of down flooding if this is less than 40 *degrees*
- (b) to comply with damage stability requirements.

1.3.6.3 Air pipes are not to be fitted with valves that may impair the venting function.

1.4 Deck Houses and Companionways

1.4.1 Applicability

1.4.1.1 The requirements of this section are applicable to steel deck houses and companionways, as defined in **1.4.3.1** and **1.4.3.2**.

1.4.1.2 Scantling requirements depend on the vertical location of the item relative to the waterline. This location is categorized in terms of “tiers”.

1.4.2 Materials

1.4.2.1 The scantlings in **1.4** apply to structures constructed of hull structural steel, in accordance with the requirements of **Section 6/1**. Scantlings of aluminium alloy deck houses will be considered by the Society, supported by the submission of a specification of the proposed alloys.

1.4.3 Definitions

1.4.3.1 A deck house is defined as a decked structure, above the strength deck, with the side plating being inboard of the shell plating by more than 4% of the ship’s breadth, *B*.

1.4.3.2 A companionway is defined as a weathertight deck structure; protecting an access opening leading below the freeboard deck, or into a space within an enclosed superstructure.

1.4.3.3 A tier is defined as a measure of the extent of a deck house. A deck house tier consists of a deck and external bulkheads. In general, the first tier is the tier situated on the freeboard deck.

1.4.4 Structural continuity

1.4.4.1 In deck houses aft, the front bulkhead is to be in line with a transverse bulkhead in the hull below or is to be supported by a combination of partial transverse bulkheads, girders and pillars.

1.4.4.2 The aft end bulkhead is to be effectively supported.

1.4.4.3 At the corners of the deck house attachment at the strength deck, attention is to be given to the connection of the deck house to the deck and the arrangements to transmit load into the under-deck supporting structure.

1.4.4.4 As far as practicable, exposed sides and main longitudinal and transverse bulkheads are to be located above bulkheads and/or deep girder frames in the hull structure, and are to be in line in the various tiers of accommodation. Where such structural arrangement in line is not possible, there is to be other effective support.

1.4.4.5 Arrangements are to be made to minimize the effect of discontinuities in erections. All openings cut in the sides are to be substantially framed and have well-rounded corners. Continuous coamings or girders are to be fitted below and above doors and similar openings.

1.4.5 Deck plating

1.4.5.1 The gross thickness of the plating, t_{dk-grs} , is not to be less than:

$$t_{dk-grs} = 7.5 \sqrt{\frac{k s}{s_{std}}} \quad (mm), \text{ on first tier deck houses}$$

$$t_{dk-grs} = 7.0 \sqrt{\frac{k s}{s_{std}}} \quad (mm), \text{ on second tier deck houses}$$

$$t_{dk-grs} = 6.5 \sqrt{\frac{k s}{s_{std}}} \quad (mm), \text{ on third tier and above deck house}$$

Where:

s : spacing of stiffeners, in *m*

k : higher strength steel factor, as defined in **Section 6/1.1.4**

σ_{yd} : specified minimum yield stress of the material, in N/mm^2

s_{std} : standard reference spacing of longitudinals or beams, in *m*:
 $= 0.470 + 0.00167L_1$

L_l : rule length, as defined in **Section 4/1.1.1.1**, but is not to be taken greater than $250m$

1.4.5.2 The plating thickness inside deck houses may be reduced by 10 percent provided that the reduced gross thickness, t_{dh-grs} , is not less than:

$$t_{dh-grs} = (5.8s + 1)\sqrt{k} \quad mm, \text{ but is not to be less than } 5.5mm$$

Where:

s : spacing of stiffeners, in m

k : higher strength steel factor, as defined in **Section 6/1.1.4**

σ_{yd} : specified minimum yield stress of the material, in N/mm^2

1.4.6 Deck longitudinals and beams

1.4.6.1 For each longitudinal or beam, in association with the plating to which it is attached, the gross section modulus, $Z_{lng-grs}$, is not to be less than:

$$Z_{lng-grs} = 4.563s l_{bdg}^2 h_{tier} k \quad (cm^3)$$

Where:

s : spacing of stiffeners, in m

l_{bdg} : effective bending span, as defined in **Section 4/2.1.1**, in m

B : as defined in **Section 4/1.1.3.1**

h_{tier} : load head in relation to the deck house tier, in m

1.68 for poop and first tier above freeboard deck

1.30 for second tier above freeboard deck

0.91 for third and higher tiers above freeboard deck

For decks with position second tier or higher above the freeboard

deck, generally used only as weather covering, the value of h_{tier} may be reduced, but in no case is it to be less than 0.46

k : higher strength steel factor, as defined in **Section 6/1.1.4**

σ_{yd} : specified minimum yield stress of the material, in N/mm^2

1.4.7 Deck girders and transverses

1.4.7.1 Deck girders and transverses are to be arranged to support beams or deck longitudinals. Where arrangements of deck girders and transverses are such that these members act as a grillage structure, additional analysis may be carried out to consider grillage effects and justify that scantlings are equivalent to those required by **1.4.7.2** and **1.4.7.3**. In this analysis gross scantlings are to be used, basic geometry parameters are to be as indicated in **1.4.7.2**, the load is to be taken as the head required by **1.4.7.2** with a unit density of $0.715 \text{tonnes}/m^3$ and the permissible bending stress is to be taken as $0.67\sigma_{yd}$. For the determination of equivalent scantlings to those required by **1.4.7.3**, equivalency is to be based on the deflection at girder/transverse intersection points and at midspan of the members, and the permissible deflection is to be taken as the deflections calculated for a simple beam meeting the requirements of **1.4.7.2** and with depth d_{grd} as required by **1.4.7.3**.

1.4.7.2 For each deck girder or transverse web, the gross section modulus, Z_{t-grs} , is not to be less than:

$$Z_{t-grs} = 4.74b_{dk} l_{bdg}^2 h_{tier} k \quad (cm^3)$$

Where:

b_{dk} : mean breadth of the area of deck supported, in m

l_{bdg} : effective bending span, to be taken as the distance between centres of supporting pillars, or between pillars, transverse members, girders and/or bulkheads supporting them, in m . Where an effective bracket is fitted at the bulkhead, the length l_{bdg} may be modified, see **Section 4/2.1.4**

h_{tier} : load head in relation to the deck house tier, in m

1.68 for poop and first tier above freeboard deck

1.30 for second tier above freeboard deck

0.91 for third and higher tiers above freeboard deck

For decks with position second tier or higher above the freeboard deck,

generally used only as weather covering, the value of h_{tier} may be reduced, but in no case is it to be less than 0.46

k : higher strength steel factor, as defined in **Section 6/1.1.4**

σ_{yd} : specified minimum yield stress of the material, in N/mm^2

1.4.7.3 The depth of girders and transverse webs, d_{grd} , is not to be less than:

$$d_{grd} = 0.0583 l_{bdg} \quad (m)$$

Where:

l_{bdg} : effective bending span, to be taken as the distance between centres of supporting pillars, or between pillars, transverse members, girders and/or bulkheads supporting them, in m . Where an effective bracket is fitted at the bulkhead, the length l_{bdg} may be modified, see **Section 4/2.1.4**

Where girders and transverse webs intersect, consideration may be given to accept a lesser depth for the longer member, where the shorter member provides full support to the longer member.

1.4.7.4 The gross thickness of girders or transverse webs is not to be taken as less than $1mm$ per $100mm$ of depth, plus an additional $4mm$. Where web shear strength and buckling capacity are demonstrated to be satisfactory, lesser thicknesses may be accepted. For shear strength analysis gross scantlings are to be used, basic geometry parameters are to be as indicated in **1.4.7.2**, the load is to be taken as the head required by **1.4.7.2** with a unit density of $0.715 \text{ tonnes}/m^3$ and the permissible shear stress is to be taken as $0.39\sigma_{yd}$. Buckling capacity is demonstrated as satisfactory when the depth to gross thickness ratio of the web is less than 75.

1.4.8 Pillars

1.4.8.1 The gross scantlings of pillars are to be such that the permissible load, determined in accordance with **1.4.8.2**, is greater than the design load, determined in accordance with **1.4.8.3**, considering the requirement of **1.4.8.4**.

1.4.8.2 The permissible loading on a pillar, W_{perm} , is given by:

$$W_{perm} = (f_{s1} - h_{pill} f_{s2}/r_{gyr-grs}) A_{pill-grs} \quad (kN)$$

Where:

f_{s1} : steel factor

12.09	normal strength steel
13.59	HT27 strength steel
16.11	HT32 strength steel
17.12	HT34 strength steel
18.12	HT36 strength steel
20.14	HT40 strength steel

h_{pill} : distance between the top of the pillar supporting deck or other structure to the underside of the supported beam or girder, in m

f_{s2} : steel factor

4.44	normal strength steel
5.57	HT27 strength steel
7.47	HT32 strength steel
8.24	HT34 strength steel
9.00	HT36 strength steel
10.52	HT40 strength steel

$r_{gyr-grs}$: radius of gyration for gross pillar section, in cm

$A_{pill-grs}$: gross cross sectional area of pillar, in cm^2

1.4.8.3 The design load for a specific pillar, W_{des} , is given by:

$$W_{des} = 7.04 b_{dk} h_{tier} l_{dk} \quad (kN)$$

Where:

b_{dk} : mean breadth of the area of deck supported, in m

h_{tier} : Load head in relation to the deck house tier, in m
 1.68 for poop and first tier above freeboard deck

1.30 for second tier above freeboard deck

0.91 for third and higher tiers above freeboard deck

For decks with position second tier or higher above the freeboard deck, generally used only as weather covering, the value of h_{tier} may be reduced, but in no case is it to be less than 0.46

l_{dk} : mean length of the area of deck supported, in m

1.4.8.4 Where pillars are arranged in a vertical line, the design load on the pillar at each level is to be calculated by summing the design load for the deck directly above the pillar and one-half of the design load for each pillar above.

1.4.9 Exposed bulkheads

1.4.9.1 The scantlings of the exposed bulkheads of deck houses and companionways are to be in accordance with **1.4.10** to **1.4.13**. Increased scantlings may be required where the structure supports loads from deck equipment, fittings, etc.

1.4.9.2 Special consideration may be given to the bulkhead scantlings of deck houses which do not protect openings in the freeboard deck, superstructure deck or in the top of a lowest tier deck house. Special consideration may also be given to the bulkhead scantlings of deck houses which do not protect machinery casings, provided they do not contain accommodation or do not protect equipment essential to the operation of the vessel.

1.4.9.3 Long deck houses may need additional support in order to provide resistance to racking, see **1.4.13**.

1.4.10 Exposed bulkhead plating

1.4.10.1 The gross thickness of plating, $t_{blk-grs}$, is not to be less than that calculated from **1.4.10.2** and that given by:

$$t_{blk-grs} = 3s\sqrt{k h_{des}} \quad (mm)$$

Where:

s : spacing of stiffeners, in m

k : higher strength steel factor, as defined in **Section 6/1.1.4**

σ_{yd} : specified minimum yield stress of the material, in N/mm^2

h_{des} : design head, in m

$$C_4[(C_5 f) - z]c$$

but is not to be taken less than given below for the specified location:

$$2.5 + L_1 / 100 \quad \text{unprotected front bulkheads on the lowest tier}$$

$$1.25 + L_2 / 200 \quad \text{elsewhere}$$

L_1 : rule length, L_{CSR-T} , as defined in **Section 4/1.1.1.1**, but is not to be taken greater than $250m$

L_2 : rule length, L_{CSR-T} , as defined in **Section 4/1.1.1.1**, but is not to be taken greater than $300m$

C_4 : coefficient as given in **Table 11.1.6**

C_5 : coefficient

$$1.0 + \left[\frac{(x/L_{CSR-T}) - 0.45}{C_{bl} + 0.2} \right]^2 \quad \text{where } x/L_{CSR-T} \leq 0.45$$

$$1.0 + 1.5 \left[\frac{(x/L_{CSR-T}) - 0.45}{C_{bl} + 0.2} \right]^2 \quad \text{where } x/L_{CSR-T} > 0.45$$

C_{bl} : block coefficient as defined in **Section 4/1.1.9.1**, but is not to be taken as less than 0.60 or greater than 0.80. For aft end bulkheads forward of amidships, C_{bl} may be taken as 0.80

x : distance between the A.P. and the bulkhead being considered, in m .

Deck house side bulkheads are to be divided into equal parts not exceeding $0.15L_{CSR-T}$ in length, and x is to be measured from the A.P. to the centre of each part considered

L_{CSR-T} : rule length, as defined in **Section 4/1.1.1.1**

f : as defined in **Table 11.1.7**

- z : vertical distance from the summer load waterline measured to the middle of the plate, in m
 c $0.3 + 0.7b_{dh}/B_1$
 but is not to be taken as less than 1.0 for exposed machinery casing bulkheads and in no case is b_{dh}/B_1 to be taken as less than 0.25
 b_{dh} : breadth of deck house at the position being considered, in m
 B_1 : actual breadth of the vessel at the freeboard deck at the position being considered, in m

 Table 11.1.6 Values of 'C₄'

Bulkhead location	Value of 'C ₄ '
Unprotected front, lowest tier	$2.0 + L_2/120$
Unprotected front, 2 nd tier	$1.0 + L_2/120$
Unprotected front, 3 rd tier and above	$0.5 + L_2/150$
Protected front, all tiers	$0.5 + L_2/150$
Sides, all tiers	$0.5 + L_2/150$
Aft ends, aft of amidships, all tiers	$0.7 + (L_2/1000) - 0.8x/L_{CSR-T}$
Aft ends, forward of amidships, all tiers	$0.5 + (L_2/1000) - 0.4x/L_{CSR-T}$

Table 11.1.7 Values of 'f'

L_{CSR-T} , in m	f , in m
90	6.00
100	6.61
120	7.68
140	8.65
160	9.39
180	9.88
200	10.27
220	10.57
240	10.78
260	10.93
280	11.01
≥ 300	11.03

Note :

This Table is based on the equations given in **Table 11.1.8**

Table 11.1.8 Origin of 'f' Values

L_{CSR-T} , in m	f , in m
$L_{CSR-T} \leq 150$	$(L_{CSR-T}/10)(e^{-L_{CSR-T}/300}) - [1 - (L_{CSR-T}/150)^2]$
$150 < L_{CSR-T} < 300$	$(L_{CSR-T}/10)(e^{-L_{CSR-T}/300})$
$L_{CSR-T} \geq 300$	11.03

1.4.10.2 The gross thickness for the lowest tier bulkheads, $t_{blk-tier-grs}$, is not to be less than:

$$t_{blk-tier-grs} = 5.0 + L_1/100 \quad (mm)$$

For other tiers, the gross thickness of bulkheads is not to be less than:

$$t_{blk-tier-grs} = 4.0 + L_1/100 \quad (mm), \text{ or } 5.0mm, \text{ whichever is greater}$$

Where:

L_1 : rule length, L_{CSR-T} , as defined in **Section 4/1.1.1.1**, but is not to be taken greater than 250m

1.4.11 Exposed bulkhead stiffeners

1.4.11.1 Each stiffener, in association with the plating to which it is attached, is to have a gross section modulus, $Z_{blk-grs}$, not less than:

$$Z_{blk-grs} = 3.5 s h_{tween}^2 h_{des} k \quad (cm^3)$$

Where:

s : spacing of stiffeners, in m

h_{tween} : 'tween deck height, in m

h_{des} : design head, as defined in **1.4.10.1**, with z taken as the vertical distance from the summer load waterline to midpoint of the stiffener span, in m

k : higher strength steel factor, as defined in **Section 6/1.1.4**

σ_{yd} : specified minimum yield stress of the material, in N/mm^2

1.4.12 Stiffener end attachments for stiffeners on exposed bulkheads

1.4.12.1 Both ends of the webs of lowest tier bulkhead stiffeners are to be effectively attached. The scantlings of stiffeners having other types of end connection will be specially considered.

1.4.13 Web arrangements for webs on exposed bulkheads

1.4.13.1 In long deck houses with multiple tiers, web frames or partial bulkheads are to be fitted within the first tier, spaced a maximum of approximately $9m$ apart and arranged, where practicable, in line with watertight bulkheads below.

1.4.13.2 Webs are also to be arranged in way of large openings, boats davits and other points of high loading.

1.4.14 Closing arrangements for openings in deck houses and companionways

1.4.14.1 All openings in the bulkheads of deck houses and companionways, which give direct access to enclosed superstructures or to spaces below the freeboard, are to be provided with efficient means of closing so that in any sea condition, water will not penetrate the vessel.

1.4.14.2 Doors of such openings are to be of steel or other equivalent material, permanently and strongly attached to the bulkhead. The doors are to be provided with gaskets and clamping devices, or other equivalent arrangements, which are to be permanently attached to the bulkhead or to the doors themselves. The doors are to be so arranged that they can be operated from both sides of the bulkhead. Doors complying with a recognized national or international standard will generally be accepted.

1.4.14.3 Access openings are to be framed and stiffened so that the whole structure is equivalent to the un-pierced bulkhead when closed.

1.4.14.4 Except as permitted by **1.4.14.5**, access doors, air inlets and openings to accommodation spaces, control stations and machinery spaces, are not to face the cargo tank region. They are to be located on the transverse bulkhead or on the side of the deck house at a distance of at least $0.04L_{CSR-T}$ and not less than $3m$ from the end of the deck house facing the cargo tank region. This distance need not exceed $5m$.

1.4.14.5 Access doors in boundary bulkheads facing the cargo tank region, or within the $5m$ limits specified in **1.4.14.4**, leading to the main cargo control stations and to such service spaces used as provision rooms, store rooms and lockers, may be permitted, provided they do not give access directly or indirectly to any other space containing or providing for accommodation, control stations or service spaces such as galley, pantries or work shops, or similar spaces containing source of vapour ignition. The boundary of such a space is to be insulated to "A-60" class standard, with the exception of the boundary facing the cargo tank region.

1.4.15 Sills of access openings

1.4.15.1 The height of the sills of access openings, in the bulkheads of deck houses and companionways, which give direct access to enclosed superstructures or to spaces below the freeboard deck, is to be a minimum of $600mm$ in Position 1 and $380mm$ in Position 2, as defined in **Section 4/1.2**.

1.4.16 Access openings in machinery casings on Type 'A' freeboard tankers

1.4.16.1 In general, there are to be no openings giving direct access from the freeboard deck to the machinery space in exposed machinery casings.

1.4.16.2 A door complying with the requirements of **1.4.14.1** to **1.4.14.3** may be permitted in the exposed machinery casing provided that it leads to a space or passageway which is as strongly constructed as the casing, and is separated from the engine room by a second door complying with the requirements of **1.4.14.1** to **1.4.14.3**. The sill of the exterior door is not to be taken less than 600mm and the sill of the second door is not to be taken less than 230mm.

1.4.17 Windows and side scuttles

1.4.17.1 Side scuttles, in the external bulkheads of deck houses and weathertight doors, are to be of substantial construction in accordance with a recognised national or international standard.

1.4.17.2 Windows and side scuttles, fitted in the boundaries of deck houses protecting direct access into superstructures, or to spaces below the freeboard deck, are to be fitted with efficient hinged inside deadlights.

1.4.17.3 Windows and portlights facing the cargo tank region, and on the side of the superstructures or deck houses within the limits specified in **1.4.14.4** and **1.4.14.5**, shall be of a fixed (non-opening) type. Such windows and portlights, except wheelhouse windows, shall be constructed to “A-60” class standard.

1.5 Scuppers, Inlets and Discharges

1.5.1 Drains – enclosed spaces

1.5.1.1 Scuppers and discharges which drain spaces below the freeboard deck, or spaces within intact superstructures or deck houses on the freeboard deck, fitted with doors complying with the requirements of the *International Convention on Load Lines, Regulation 12*, may be led to the bilges in the case of scuppers, or to suitable sanitary tanks in the case of sanitary discharges. Alternatively, they may be led overboard, provided that:

- (a) the freeboard is such that the deck edge is not immersed when the ship heels to five degrees either way, and
- (b) each drain is fitted with means of preventing water from passing inboard, in accordance with **1.5.3**.

1.5.2 Drains – open spaces

1.5.2.1 Drains leading from superstructures or deck houses not fitted with doors complying with the requirements of *International Convention on Load Lines, Regulation 12* are to be led overboard.

1.5.3 Prevention of water passing inboard

1.5.3.1 Drains either from spaces below the freeboard deck or from within superstructures and deck houses on the freeboard deck, where permitted to be led overboard, see **1.5.1.1(a)**, are to be fitted with efficient and accessible means for preventing water from passing inboard, in accordance with **1.5.3.2** to **1.5.3.7**.

1.5.3.2 For drains which remain open during normal operation of the ship, such as sanitary discharges, means for preventing water passing inboard are to be in accordance with those given below for the area described. h_{disc} is the height from the summer load line to the inboard end of the discharge, in m :

- (a) $h_{disc} \leq 0.01L_L$:
 - one automatic non-return valve with a positive means of closing it from a position above the freeboard deck
 - alternatively, one automatic non-return valve and one positive closing valve controlled from above the freeboard deck may be accepted.
- (b) $0.01L_L < h_{disc} \leq 0.02L_L$:
 - two automatic non-return valves, without positive means of closing, provided that the inboard valve is always accessible for examination under service conditions
 - the inboard valve is to be located above the deepest salt water load line
 - if this is not practicable, additional locally controlled positive closing may be provided outboard, or the outboard non-return valve may be provided with a locally controlled positive closing feature, in which case the inboard valve need not be located above the deepest salt water load line.
- (c) $h_{disc} > 0.02L_L$:
 - one single automatic non-return valve without positive means of closing.

1.5.3.3 For overboard discharges in way of machinery spaces, a locally operated positive closing valve at shell together with a non-return valve inboard, may be accepted in lieu of those required by **1.5.3.2**.

1.5.3.4 For acceptable arrangements for discharges and scuppers, see **Fig. 11.1.3**.

Fig. 11.1.3 Diagrammatic Arrangement of Discharge and Scupper Systems

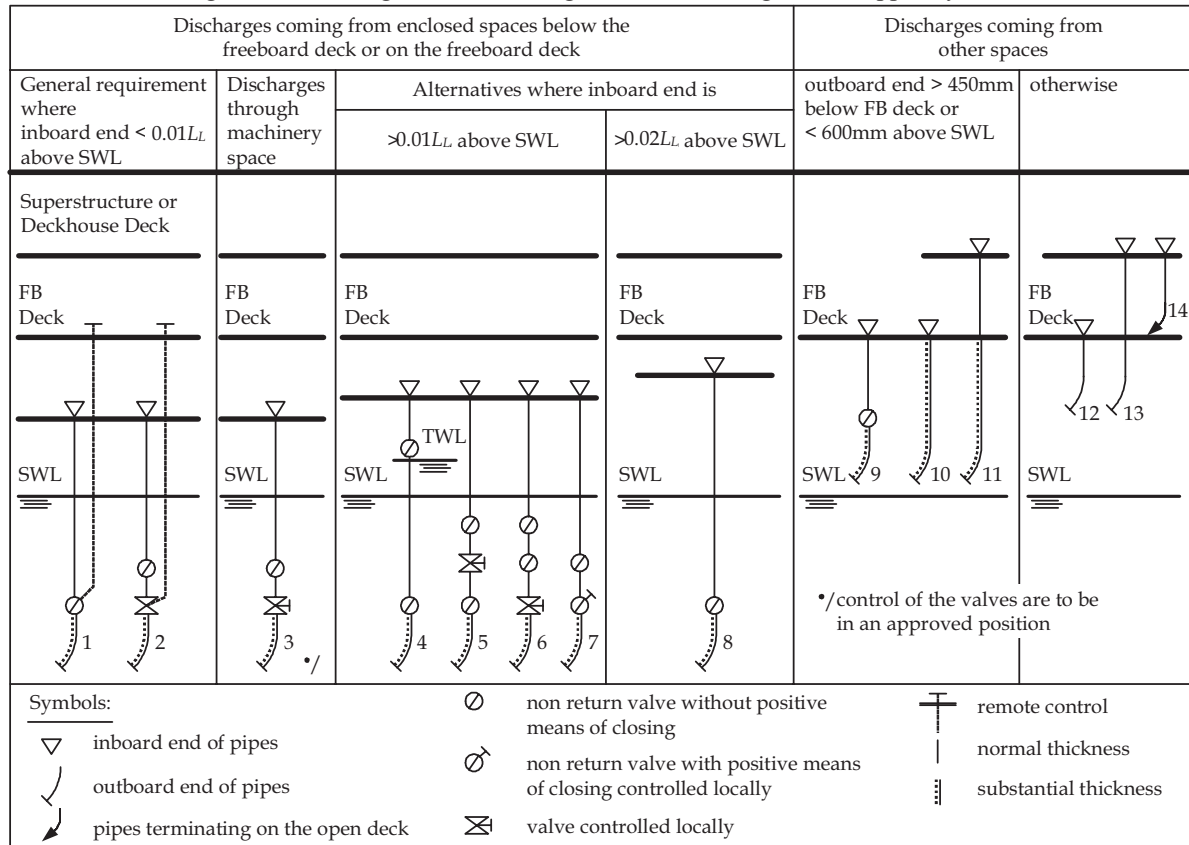

1.5.3.5 For drains which are closed at sea, such as gravity drains from topside ballast tanks, a single screw down valve operated from the deck may be accepted.

1.5.3.6 The means for operating the positive closing valve are to be readily accessible and provided with an indicator showing whether the valve is open or closed.

1.5.3.7 Drain pipes originating at any level and penetrating the shell either more than 450mm below the freeboard deck or less than 600mm above the summer load waterline are to be provided with a non-return valve at the shell. This valve, unless required by 1.5.3.2 through 1.5.3.4, may be omitted if the pipe is of substantial thickness, in accordance with 1.5.7.3.

1.5.4 Sea inlets

1.5.4.1 In manned machinery spaces, main and auxiliary sea inlets and discharges in connection with the operation of machinery may be controlled locally. The control is to be readily accessible and provided with indicators showing whether the valves are open or closed.

1.5.5 Shell valves and fittings

1.5.5.1 For installation; the shell valves are to be mounted on the shell (or sea chest). However, where it is impracticable to do so, a distance piece, of substantial thickness in accordance with 1.5.7.3, may be fitted. Shell outlets are to be so located as to prevent any discharge falling onto a lowered survival craft.

1.5.5.2 For material; all required shell valves and fittings are to be of steel, bronze or other approved ductile material. Valves of ordinary cast iron or similar material are not acceptable.

1.5.5.3 Material readily rendered ineffective by heat is not to be used for shell connection where the failure of the material in case of fire would give rise to danger of flooding.

1.5.6 Unattended machinery space

1.5.6.1 For unattended machinery space; the control of any valve serving a sea inlet, a discharge below the waterline, or a bilge injection system, is to be so sited as to allow adequate time to reach and operate the control, in case of ingress of water to the space with the ship in the fully loaded condition.

1.5.6.2 For application of **1.5.6.1** in an unattended machinery space; where it can be demonstrated by calculation that the damaged water line will not be above the tank top floor level after 10 *minutes* from the initiation of the uppermost bilge level alarm, the valve control may be from the tank top floor.

Guidance Note:

Various Flag Administrations have interpretations of this requirement. Where the ship is flagged by an Administration having an interpretation of this requirement, the interpretation of the Flag Administration shall take precedence or the requirements of **1.5.6.2**.

1.5.7 Pipes

1.5.7.1 All pipes from shell to the first valve are to be of steel or other equivalent material.

1.5.7.2 The gross wall thickness of steel piping inboard of the valve is not to be less than that given in **Table 11.1.9**, unless substantial thickness is required.

Table 11.1.9 Thickness of Normal Steel Piping

External diameter, in <i>mm</i>	Gross wall thickness, in <i>mm</i>
≤ 155	4.5
≥ 230	6.0

Note :

Intermediate values are to be obtained by linear interpolation.

1.5.7.3 The gross wall thickness of steel piping, where required to be of substantial thickness, see **1.5.3.7** and **1.5.5.1**, is not to be less than given in **Table 11.1.10**.

Table 11.1.10 Thickness of Substantial Steel Piping

External diameter, in <i>mm</i>	Gross wall thickness, in <i>mm</i>
≤ 80	7.0
180	10.0
≥ 220	12.5

Note :

Intermediate values are to be obtained by linear interpolation.

1.5.8 Rubbish chutes, offal and similar discharges

1.5.8.1 Rubbish chutes, offal, and similar discharges are to be constructed of mild steel piping or plating equal to the shell thickness. Other materials will be specially considered.

1.5.8.2 Openings are to be kept clear of the sheer strake and areas of high stress concentration.

1.5.8.3 Rubbish chute hoppers are to be provided that comprise a hinged weathertight cover at the inboard end with an interlock so that the discharge flap and hopper cover cannot be open at the same time.

1.5.8.4 The hopper cover is to be secured closed when not in use, and a suitable notice is to be displayed at the control position.

1.5.8.5 Where the inboard end of the hopper is less than $0.01L_L$, a positive closing valve is to be provided in addition to the cover and flap, in an easily accessible position above the deepest salt water load line.

1.5.8.6 The valve is to be controlled from a position adjacent to the hopper and provided with an open/shut indicator. The valve is to be kept closed when not in use, and a notice to that effect is to be displayed at the valve operating position.

2. Crew Protection

2.1 Bulwarks and Guardrails

2.1.1 General

2.1.1.1 Bulwarks or guard rails are to be provided at the boundaries of exposed freeboard and superstructure decks, at the boundary of first tier deck houses and at the ends of superstructures.

2.1.1.2 Bulwarks, or guard rails, are to be a minimum of 1.0m in height, measured above sheathing, and are to be constructed as required in 2.1.2. Where this height would interfere with the normal operation of the vessel, a lesser height may be approved. Where approval of a lower height is requested, justifying information is to be submitted.

2.1.1.3 Within $0.6L_{CSR-T}$ amidships, bulwarks are to be arranged to ensure that they are free from hull girder stresses.

2.1.1.4 Satisfactory means in the form of guard rails, life lines, gangways, under deck passages or an equivalent are to be provided for the protection of crew during passage from their quarters, the machinery space, and all other locations necessary for the crewing of the ship, see 2.3.1.1.

2.1.2 Construction of bulwarks

2.1.2.1 The gross thickness of bulwark plating, at the boundaries of exposed freeboard and superstructure decks, is not to be less than that given in Table 11.2.1.

Table 11.2.1 Thickness of Bulwark Plates

Height of Bulwark	Gross Thickness
1.8m or more	As required for superstructure in the same position
1.0m	6.5mm
Intermediate height	To be determined by linear interpolation

2.1.2.2 Plate bulwarks are to be stiffened by a top rail. Plate bulwarks on the freeboard deck and forecastle deck are to be supported by stays having a spacing generally not greater than 2.0m.

2.1.2.3 The free edge of the stay is to be stiffened.

2.1.2.4 The gross section modulus of stays, $Z_{stay-grs}$, is not to be less than that given below. In the calculation of the section modulus, only the material connected to the deck is to be included. The bulb or flange of the stay may be taken into account where connected to the deck. Where, at the ends of the ship, the bulwark plating is connected to the sheer strake, a width of attached plating, not exceeding 600mm, may also be included.

$$Z_{stay-grs} = 77h_{blwk}^2 s_{stay} \quad (cm^3)$$

Where:

h_{blwk} : height of bulwark from the top of the deck plating to the top of the rail, in m

s_{stay} : spacing of the stays, in m

2.1.2.5 Where mooring fittings subject the bulwark to large forces, the strength of the stays is to be suitably upgraded.

2.1.2.6 Bulwark stays are to be supported by, or are to be in line with, suitable under deck stiffening. The stiffening is to be connected by double continuous fillet welds in way of bulwark stay connections.

2.1.2.7 Where bulwarks are cut to form a gangway or other opening, stays of increased strength are to be fitted at the ends of openings.

2.1.2.8 Bulwarks are to be adequately strengthened and increased in thickness in way of mooring pipes.

2.1.2.9 Cuts in bulwarks for gangways or other openings are to be kept clear of breaks of superstructures.

2.1.2.10 Where bulwarks are fitted, freeing ports are to be provided as required in 2.1.5. The freeing ports are to comply with 23.2, Part C of the Rules.

2.1.3 Construction of guard rails

2.1.3.1 Stanchions of guard rails required by 2.1.1.1 are to comply with the following requirements:

- (a) fixed, removable or hinged stanchions are to be fitted approximately 1.5m apart
- (b) at least every third stanchion is to be supported by a bracket or stay
- (c) removable or hinged stanchions are to be capable of being locked in the upright position
- (d) in the case of ships with rounded gunwales, the stanchions are to be placed on the flat of the deck
- (e) in the case of ships with sheer strake, the stanchions are not to be attached to the sheer strake, upstand or a continuous gutter bar.

2.1.3.2 The size of openings, below the lowest course of rails and the deck or upstand, is to be a maximum of 230mm. The distance between other courses is not to be greater than 380mm.

2.1.3.3 Wire ropes may be accepted, in lieu of guard rails, only in special circumstances and then only in limited lengths. In such cases, they are to be made taut by means of turnbuckles.

2.1.3.4 Chains may be accepted, in lieu of guard rails, only where they are fitted between two fixed stanchions and/or bulwarks.

2.1.4 Additional requirements for bulwarks and guard rails related to spill containment

2.1.4.1 Generally, open guard rails are to be fitted on the upper deck. Plate bulwarks, with a 230mm high continuous opening, at the lower edge, may be accepted provided the arrangement allows for the acceptable handling of spillage on deck and minimises the possibility for accumulation of volatile gas.

2.1.4.2 Deck spills are to be prevented from spreading to the accommodation and service areas and from discharge into the sea by a permanent continuous coaming with a minimum height of 100mm surrounding the cargo deck. Along the sides at the aft end of the cargo deck, the coaming is to have a minimum height of 200mm extending a minimum of 4.5m forward from each corner. At the aft end of the cargo deck, the coaming is to have a minimum height of 300mm and is to extend from ship-side to ship-side.

2.1.4.3 Where a continuous gutter bar deck coaming is fitted, it is to be constructed of the same material strength and grade as the deck plating to which it is attached.

2.1.4.4 Scupper plugs of mechanical type are to be provided. Means of draining or removing oil or oily water within the coaming are also to be provided.

2.1.5 Additional requirements for deeper loading

2.1.5.1 Ships with Type A or B-100 Freeboard (i.e. a freeboard less than that based on Type B-60) are to have open rails fitted for a minimum of half the length of the exposed parts of the weather deck. Alternatively, if a continuous bulwark is fitted, the minimum freeing area is to be at least 33% of the total area of the bulwark. The freeing area is to be located in the lower part of the bulwark.

2.1.5.2 Where superstructures are connected by trunks, open rails are to be fitted for the whole length of the exposed parts of the freeboard deck.

2.1.5.3 Ships with Type B-60 Freeboard (i.e. a freeboard less than that based on Type B but not less than Type B-60) are to have a minimum freeing area of at least 25% of the total area of the bulwark. The freeing area is to be located in the lower part of the bulwark.

2.2 Tank Access

2.2.1 Access to tanks in the cargo tank region

2.2.1.1 Access to tanks in the cargo tank region is to be in accordance with Section 5/5.

2.3 Bow Access

2.3.1 General

2.3.1.1 The ship is to be provided with means to enable the crew to gain safe access to the bow even in severe weather conditions, see Table 11.2.2.

Table 11.2.2 Acceptable Arrangements for Access

Locations of Access	Assigned Summer Freeboard	Acceptable Arrangements According to Type of Freeboard Assigned (6)(7)(8)			
		Type A	Type B-100	Type B-60	Type B & B+
Access to Bow Between poop and bow, or Between a deck house containing living accommodation or navigation equipment, or both, and bow, or In the case of a flush deck vessel, between crew accommodation and the forward end of vessel.	$\leq (h_{FB} + h_{ss})$	a e f ⁽¹⁾ f ⁽⁵⁾			
	$> (h_{FB} + h_{ss})$	a e f ⁽¹⁾ f ⁽²⁾			
Access to Aft End In the case of a flush deck vessel, between crew accommodation and the aft end of vessel.	$\leq 3000mm$	a b c ⁽¹⁾ e f ⁽¹⁾	a b c ⁽¹⁾ c ⁽²⁾ e f ⁽¹⁾ f ⁽²⁾	a b c ⁽¹⁾ c ⁽²⁾ e f ⁽¹⁾ f ⁽²⁾	a b c ⁽¹⁾ c ⁽²⁾
	$> 3000mm$	a b c ⁽¹⁾ d ⁽¹⁾ e f ⁽¹⁾	a b c ⁽¹⁾ c ⁽²⁾ d ⁽¹⁾ d ⁽²⁾ e f ⁽¹⁾ f ⁽²⁾	a b c ⁽¹⁾ c ⁽²⁾ d ⁽¹⁾ d ⁽²⁾ d ⁽³⁾ e f ⁽¹⁾ f ⁽²⁾ f ⁽⁴⁾	a b c ⁽¹⁾ d ⁽¹⁾ d ⁽²⁾ d ⁽³⁾ e f ⁽¹⁾ f ⁽²⁾ f ⁽⁴⁾

Where:

h_{ss} : the standard height of a superstructure as defined in *ICLL Regulation 33*

h_{FB} : freeboard from the summer load waterline amidships, in *m*, calculated as a Type A ship, regardless of the type of freeboard actually assigned

a : a well lit and ventilated under deck passageway with a clear opening with a minimum width of *0.8m*, and a minimum height of *2.0m*, providing access to the locations under consideration and located as close as practicable to the freeboard deck

b : a permanently constructed gangway fitted at or above the level of the superstructure deck, on or as near as practicable to the centreline of the vessel, providing a continuous platform of a non-slip surface at least *0.6m* in width, with a foot-stop and guard rails extending on each side along its length. Guard rails are to be as required in **2.1.3**, except that stanchions are to be fitted with a maximum spacing of *1.5m*

c : a permanent walkway with a minimum width of *0.6m*, fitted at the freeboard deck level, consisting of two rows of guard rails, the stanchions of which, are to have a maximum spacing of *3m*. The number of courses of rails and their spacing are to be as given in **2.1.3**. On Type B freeboard ships, hatchway coamings with a height equal to or greater than *0.6m* may be regarded as forming one side of the walkway provided that two rows of guard rails are fitted between the hatchways

Table 11.2.2 (Continued) Acceptable Arrangements for Access

- d : a rope lifeline with a minimum diameter of 10mm , supported by stanchions approximately 10m apart, or a single hand rail or wire rope attached to the hatch coamings, continued and adequately supported between hatchways
- e : a permanently constructed gangway fitted at or above the level of the superstructure deck on, or as near as practicable, to the centreline of the vessel:
- located so as not to hinder easy access across the working areas of the deck
 - providing a continuous platform with a minimum width of 1.0m
 - constructed of fire resistant and non-slip material
 - fitted with guard rails extending on each side throughout its length. Guard rails are to be as required in **2.1.3**, except that stanchions are to be fitted with a maximum spacing of 1.5m
 - provided with a foot stop on each side
 - having openings, with ladders to and from the deck, where appropriate. Openings are to be spaced a maximum of 40m apart
 - having shelters of substantial construction set in way of the gangway at intervals not exceeding 45m , if the length of the exposed deck to be traversed is greater than 70m . Every such shelter is to be capable of accommodating at least one person and be so constructed as to afford weather protection on the forward, port and starboard sides
- f : a permanent and efficiently constructed walkway fitted at the freeboard deck level on, or as near as practicable, to the centreline of the vessel, having the same specifications as those defined for a permanent gangway in 'e' above, except for foot-stops. On Type B freeboard ships the hatch coamings may be accepted as forming one side of the walkway, provided that the combined height of the hatch coaming and hatch cover, in the closed condition, is not less than 1m , and that two rows of guard rails are fitted between the hatchways

Note :

1. At or near the centreline of the vessel, or fitted on hatchways at or near the centreline of the vessel
2. Fitted on each side of the vessel
3. Fitted on one side of the vessel, provision being made for fitting on either side
4. Fitted on one side only
5. Fitted on each side of the hatchways as near to the centreline as far as practicable
6. In all cases where wire ropes are fitted, adequate devices are to be provided to enable the maintaining of their tautness
7. A means of passage over obstructions, if any, such as pipes or other fittings of a permanent nature is to be provided
8. Generally, the width of the gangway or walkway is not to exceed 1.5m .

Guidance Note :

Deviations from some or all of these requirements may be allowed, subject to agreement on a case-by-case basis with the relevant Flag Administration.

3. Support Structure and Structural Appendages

3.1 Support Structure for Deck Equipment

3.1.1 General

3.1.1.1 Information pertaining to the support structure of deck equipment and fittings, as listed in 3.1.2 to 3.1.7, is to be submitted for approval.

3.1.1.2 This sub-section includes scantling requirements for the support structure and foundations of the following pieces of equipment and fittings:

- (a) anchor windlasses
- (b) anchoring chain stoppers
- (c) mooring winches
- (d) deck cranes, derricks and lifting masts
- (e) emergency towing arrangements
- (f) bollards and bitts, fairleads, stand rollers, chocks and capstans
- (g) other deck equipment and fittings which are subject to specific approval
- (h) miscellaneous deck fittings which are not subject to specific approval.

3.1.1.3 Where deck equipment is subject to multiple load cases, such as an operational load and a green seas load, the operational load and green seas load are to be applied independently for the evaluation of strength of foundations and support structure.

3.1.2 Supporting structures for anchoring windlass and chain stopper

3.1.2.1 The windlass is to be efficiently bedded and secured to the deck. The deck thickness in way of the windlass and chain stopper is to be compatible with the deck attachment design.

3.1.2.2 In addition to complying with the requirements of 3.1.2.6, the shipbuilder and the windlass manufacturer are to satisfy themselves that the foundation is suitable for the safe operation and maintenance of the windlass equipment.

3.1.2.3 The Breaking Strength is defined as the minimum breaking strength of the chain.

3.1.2.4 The following plans and information are to be submitted for approval:

- (a) details of the supporting structure for the anchor windlass
- (b) details of the windlass foundation design, including material specifications for holding down bolts and the connection of the foundation to the deck
- (c) details of the chain stopper foundation design, including material specification and the connection of the foundation to the deck.

3.1.2.5 The following supporting information is also to be submitted:

- (a) general arrangement drawing of anchoring equipment.
- (b) design loads as specified in 3.1.2.8 and 3.1.2.9 and associated reaction forces applied to the foundation and supporting structure.

3.1.2.6 The scantlings of the support structure are to be dimensioned to ensure that for each of the load scenarios specified in 3.1.2.8 and 3.1.2.9, the calculated stresses in the support structure does not exceed the permissible stress levels given in 3.1.2.15 to 3.1.2.18.

3.1.2.7 These requirements are to be assessed using a simplified engineering analysis based on elastic beam theory, two-dimensional grillage or finite-element analysis using gross scantlings.

3.1.2.8 The following load cases are to be examined for the anchoring operation, as appropriate:

- (a) windlass where chain stopper is provided: 45% of Breaking Strength
- (b) windlass where chain stopper is not provided: 80% of Breaking Strength
- (c) chain stopper: 80% of Breaking Strength

Breaking Strength is defined in 3.1.2.3.

3.1.2.9 The following forces are to be applied separately in the load cases that are to be examined for the design loads due to green seas in the forward $0.25L_{CSR-T}$, see Fig. 11.3.1:

$$P_x = 200A_x \quad kN, \text{ acting normal to the shaft axis}$$

$$P_y = 150A_y f \quad kN, \text{ acting parallel to the shaft axis (inboard and outboard directions to be examined separately)}$$

Where:

- A_x : projected frontal area, in m^2
- A_y : projected side area, in m^2
- f = $1+B_w/H$, but not to be taken greater than 2.5
- B_w : breadth of windlass measured parallel to the shaft axis, in m .
See **Fig. 11.3.1**
- H : overall height of windlass, in m , see **Fig. 11.3.1**

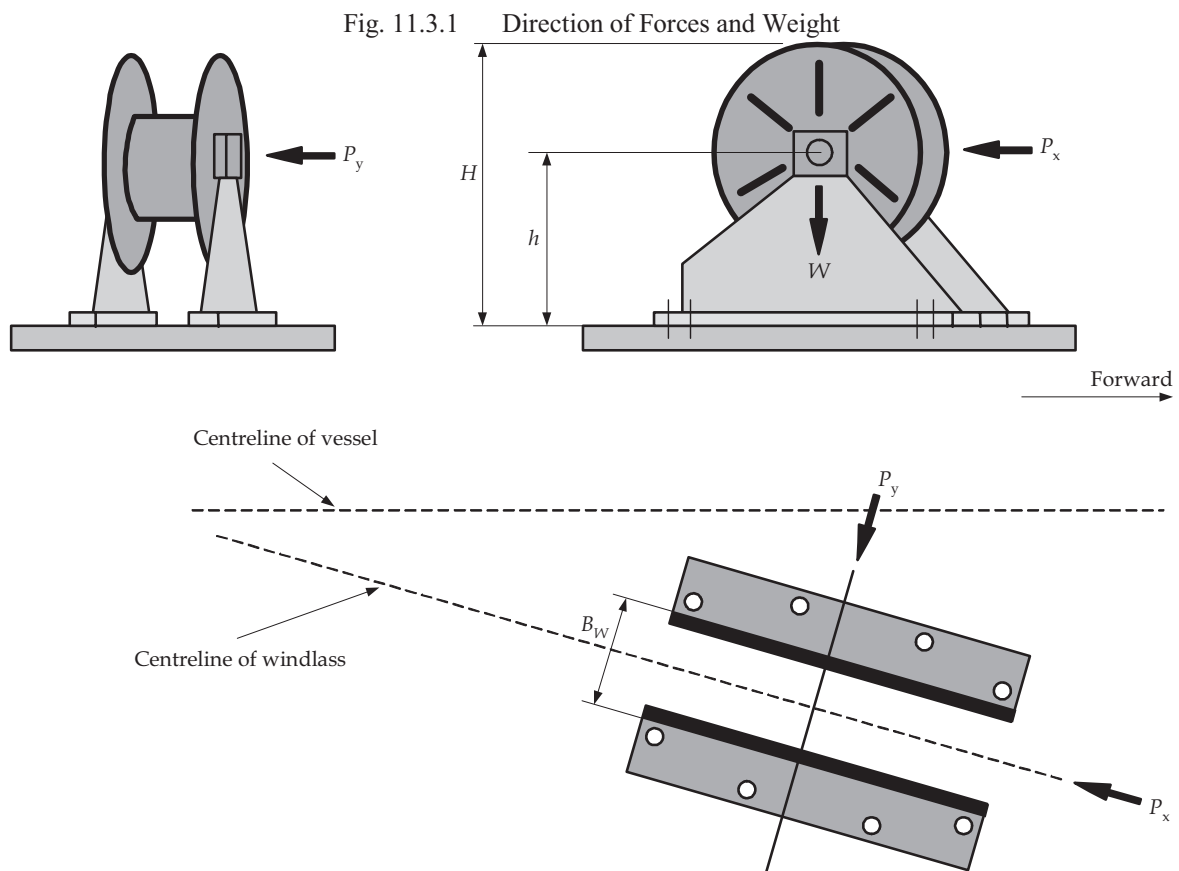

3.1.2.10 Forces resulting from green sea design loads in the bolts, chocks and stoppers securing the windlass to the deck are to be calculated. The windlass is supported by a number of bolt groups, N , each containing one or more bolts. See **Fig. 11.3.2**.

Fig. 11.3.2 Bolting Arrangements and Sign Conventions

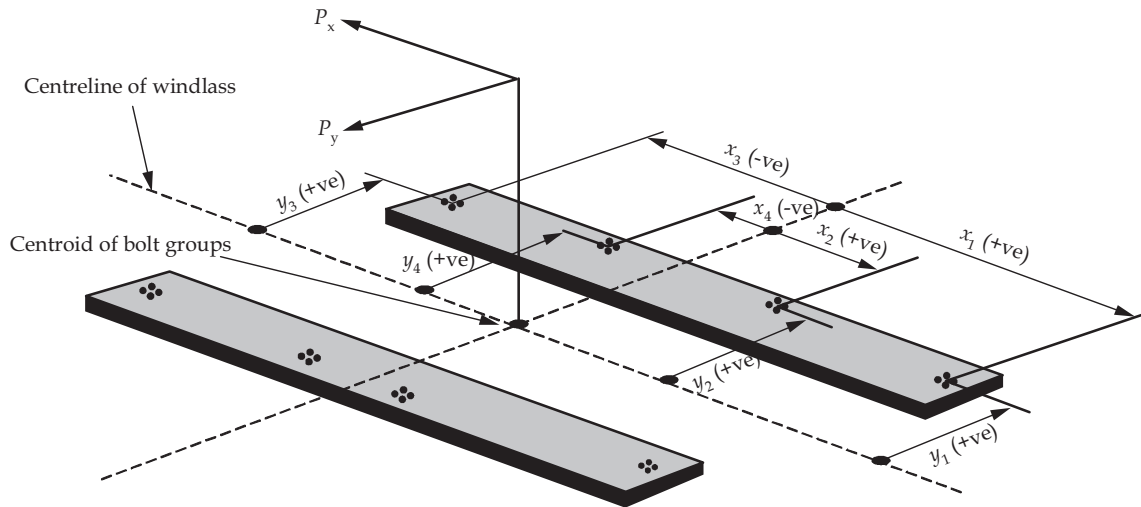

3.1.2.11 The axial forces, R_{xi} and R_{yi} , in bolt group (or bolt) i , positive in tension, are given by:

$$R_{xi} = P_x h x_i A_i / I_x$$

$$R_{yi} = P_y h y_i A_i / I_y$$

$$R_i = R_{xi} + R_{yi} - R_{si}$$

Where:

P_x : force acting normal to the shaft axis, in kN

P_y : force acting parallel to the shaft axis, either inboard or outboard, whichever gives the greater force in bolt group i , in kN

h : shaft centre height above the windlass mounting, in cm , see **Fig. 11.3.1**

x_i, y_i : x and y coordinates of bolt group i from the centroid of all N bolt groups, in cm . Positive in the direction opposite to that of the applied force

A_i : cross sectional area of all bolts in group i , in cm^2

$I_x = \sum A_i x_i^2$ for N bolt groups, in cm^4

$I_y = \sum A_i y_i^2$ for N bolt groups, in cm^4

R_{si} : static reaction at bolt group i , due to the weight of windlass, in kN

3.1.2.12 The shear forces, F_{xi} and F_{yi} , applied to the bolt group i , and the resultant combined force F_i are given by:

$$F_{xi} = (P_x - C_1 g m) / N$$

$$F_{yi} = (P_y - C_1 g m) / N$$

$$F_i = \sqrt{F_{xi}^2 + F_{yi}^2}$$

Where:

C_1 : coefficient of friction, 0.5

m : mass of windlass, in $tonnes$

g : acceleration due to gravity, $9.81m/s^2$

N : number of bolt groups

3.1.2.13 The resultant forces from the application of the loads specified in **3.1.2.8** and **3.1.2.9** are to be considered in the design of the supporting structure.

3.1.2.14 Where a separate foundation is provided for the windlass brake, the distribution of resultant forces is to be calculated on the assumption that the brake is applied for load cases (a) and (b) defined in **3.1.2.8**.

3.1.2.15 The stresses resulting from anchoring design loads induced in the supporting structure are not to be greater than the permissible values given below, based on the gross thickness of the structure:

Normal stress 1.00 σ_{yd}

Shear stress 0.58 σ_{yd}

Where:

σ_{yd} : specified minimum yield stress of the material, in N/mm^2

Normal stress is the sum of bending stress and axial stress with the corresponding shearing stress acting perpendicular to the normal stress.

3.1.2.16 The tensile axial stresses resulting from green sea design loads in the individual bolts in each bolt group i are not to exceed 50% of the bolt proof strength under the above forces. The load is to be applied in the direction of the chain. Where fitted bolts are designed to support these shear forces in one or both directions, the von Mises equivalent stresses are not to exceed 50% of the bolt proof strength.

3.1.2.17 The horizontal forces resulting from the green sea design loads F_{xi} and F_{yi} may be reacted by shear chocks. Where pourable resins are incorporated in the holding down arrangements, due account is to be taken in the calculation.

3.1.2.18 The stresses resulting from green sea design loads induced in the supporting structure are not to be greater than the permissible values given below, based on the gross thickness of the structure:

Normal stress	1.00 σ_{yd}
Shear stress	0.58 σ_{yd}

Where:

σ_{yd} : specified minimum yield stress of the material, in N/mm^2

Normal stress is the sum of bending stress and axial stress with the corresponding shearing stress acting perpendicular to the normal stress.

3.1.3 Supporting structure for mooring winches

3.1.3.1 Mooring winches are to be efficiently bedded and secured to the deck. The deck thickness in way of mooring winches is to be compatible with the deck attachment design.

3.1.3.2 In addition to complying with the requirements of 3.1.3.6, the shipbuilder and mooring winch manufacturer are to satisfy themselves that the foundation is suitable for the safe operation and maintenance of the mooring winch equipment.

3.1.3.3 The Rated Pull is defined as the maximum load which the mooring winch is designed to exert during operation and is to be stated on the mooring winch foundation/support plan.

3.1.3.4 The Holding Load is defined as the maximum load which the mooring winch is designed to resist during operation and is to be taken as the design brake holding load or equivalent and is to be stated on the mooring winch foundation/support plan.

3.1.3.5 The following plans and information are to be submitted for approval:

- details of the supporting structure for mooring winches
- details of the mooring winch foundation design, including material specifications for hold down bolts and the connection of the foundation to the deck
- design loads as specified in 3.1.3.8 and 3.1.3.9 and associated reaction forces applied to the foundation and supporting structure.

3.1.3.6 The scantlings of the support structure are to be dimensioned to ensure that, for each of the load cases specified in 3.1.3.8 and 3.1.3.9, the calculated stresses in the support structure do not exceed the permissible stress levels specified in 3.1.3.13 and 3.1.3.14, respectively.

3.1.3.7 These requirements are to be assessed using a simplified engineering analysis based on elastic beam theory, two-dimensional grillage or finite-element analysis using net scantlings.

3.1.3.8 Each of the following load cases are to be examined for design loads due to mooring operation:

- mooring winch at maximum pull: 100% of the rated pull
- mooring winch with brake effective: 100% of the holding load
- line strength: 125% of the breaking strength of the mooring line (hawser) required by **Table 11.4.2** for the ship's corresponding equipment number

Rated pull and holding load are defined in 3.1.3.3 and 3.1.3.4. The design load is to be applied through the mooring line according to the arrangement shown on the mooring arrangement plan.

3.1.3.9 For mooring winches situated within the forward $0.25L_{CSR-T}$, the load cases for green seas are to be applied as indicated in 3.1.2.9.

3.1.3.10 For mooring winches situated within the forward $0.25L_{CSR-T}$, the resultant forces in the bolts obtained from green sea design loads are to be calculated in accordance with 3.1.2.10 to 3.1.2.12.

3.1.3.11 The resultant forces from the application of the loads specified in 3.1.3.8 and 3.1.3.9 are to be considered in the design of the supporting structure.

3.1.3.12 Where a separate foundation is provided for the mooring winch brake, the distribution of resultant forces is to take account of the different load path. The brake is only to be considered in relation to the forces in 3.1.3.8, load case (b).

3.1.3.13 The stresses resulting from mooring operation design loads, induced in the supporting structure, are not to exceed those given in 3.1.2.15.

3.1.3.14 For mooring winches situated within the forward $0.25L_{CSR-T}$, the stresses resulting from green sea design loads, induced in the bolts and supporting structure, are not to exceed values indicated in 3.1.2.16 through 3.1.2.18.

3.1.4 Supporting structure for cranes, derricks and lifting masts

3.1.4.1 Support structures of cranes, derricks and lifting masts with a Safe Working Load greater than 30kN, or a maximum overturning moment to the supporting structure greater than 100kNm, are to comply with the following requirements.

3.1.4.2 These requirements apply to the connection to the deck and the supporting structure of cranes, derricks and lifting masts. Where the crane, derrick or lifting mast is to be certified by the Society, additional requirements may be applied by the Society.

3.1.4.3 These requirements do not cover the following items:

- (a) supports of lifting appliances for personnel or passengers, see 3.1.7.5
- (b) the structure of the lifting appliance pedestals or post above the area of the deck connection
- (c) holding down bolts and their arrangement, which are considered part of the lifting appliance.

3.1.4.4 The term, Lifting Appliance, is defined as a crane, derrick or lifting mast.

3.1.4.5 The Safe Working Load is defined as the maximum load which the lifting appliance is certified to lift at any specified outreach.

3.1.4.6 The Self Weight is the calculated gross self weight of the lifting appliance, including the weight of any lifting gear.

3.1.4.7 The Overturning Moment is the maximum bending moment, calculated at the connection of the lifting appliance to the ship structure, due to the lifting appliance operating at Safe Working Load, taking into account outreach and self weight.

3.1.4.8 The Crane Pedestal and Derrick Mast are as defined in Fig. 11.3.3.

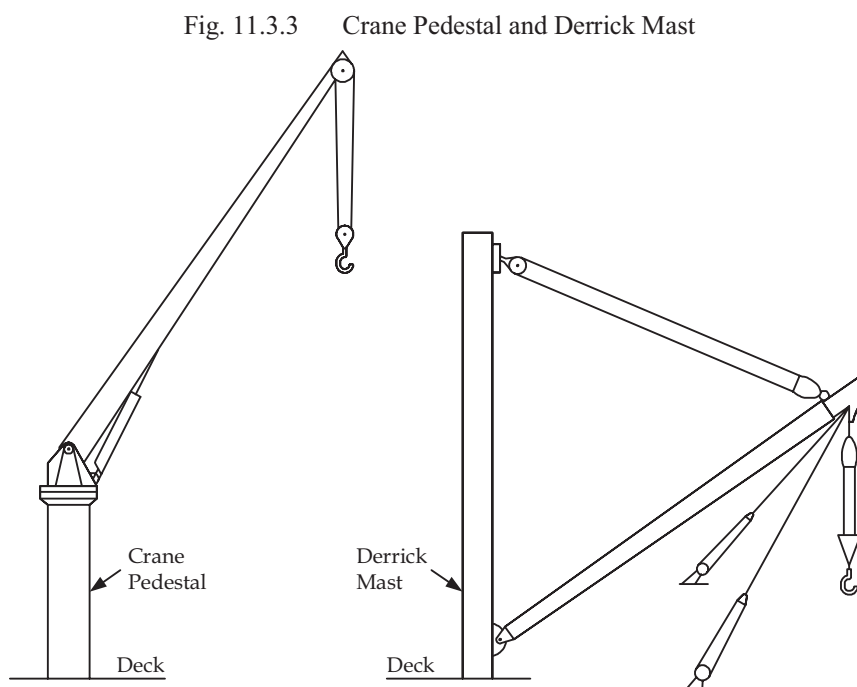

3.1.4.9 The following plans and information are to be submitted for approval:

- (a) details of the supporting structure of the lifting appliance, including its connection of the deck

(b) details of the Safe Working Load, self weight, vertical reaction forces and the maximum overturning moment in the supporting structure of the lifting appliance

(c) for offshore operation, the maximum sea state in which the lifting appliance is to be used.

3.1.4.10 The following supporting information is also to be submitted:

(a) a general arrangement drawing of the crane/derrick/lifting mast.

3.1.4.11 Deck plating and under deck structure is to provide adequate support for derrick masts against the calculated vertical loads and maximum overturning moment. Where the deck is penetrated, the deck plating is to be suitably strengthened.

3.1.4.12 Deck plating and under deck structure is to provide adequate support for crane pedestals against the calculated vertical loads and maximum overturning moment.

3.1.4.13 In general, structural continuity of the deck structure is to be maintained and deep under-deck members are to be provided to support the crane pedestal.

3.1.4.14 Depending on the arrangement of the deck connection in way of crane pedestals, the following additional requirements are to be complied with:

(a) where the pedestal is directly connected to the deck, without above deck brackets, adequate under deck structure directly in line with the crane pedestal is to be provided. Where the crane pedestal is attached to the deck without bracketing or where the crane pedestal is not continuous through the deck, welding to the deck of the crane pedestal and its under deck support structure is to be made by suitable full penetration welding. This could include a deep penetration welding procedure with a maximum root face of *3mm* provided this results in full penetration and consequently enables ultrasonic lamination testing after welding has been completed. The design of the weld connection is to be adequate for the calculated stress in the welded connection, in accordance with **3.1.4.21**.

(b) where the pedestal is directly connected to the deck with brackets, under deck support structure is to be fitted to ensure a satisfactory transmission of the load, and to avoid structural hard spots. Above deck brackets may be fitted inside or outside of the pedestal and are to be aligned with deck girders and webs. The design is to avoid stress concentrations caused by an abrupt change of section. Brackets and other direct load carrying structure and under deck support structure are to be welded to the deck by suitable full penetration welding. This could include a deep penetration welding procedure with a maximum root face of *3mm* provided this results in full penetration and consequently enables ultrasonic lamination testing after welding has been completed. The design of the connection is to be adequate for the calculated stress, in accordance with **3.1.4.21**.

3.1.4.15 Deck plates are to be of a thickness and material strength compatible with the crane pedestal. Where necessary, a thicker insert plate is to be fitted. In no case are doublers to be used where structures are subject to tension.

3.1.4.16 The scantlings of the support structure are to be dimensioned to ensure that for the load cases specified in **3.1.4.18** and **3.1.4.19**, the calculated stresses in the support structure do not exceed those given in **3.1.4.21**.

3.1.4.17 These requirements are to be assessed using a simplified engineering analysis based on elastic beam theory, two-dimensional grillage or beam element finite-element analysis using gross scantlings.

3.1.4.18 For lifting appliances which are limited to use in harbour, the following load scenario is to be examined:

(a) 130% of the Safe Working Load added to the lifting appliances self weight.

3.1.4.19 For lifting appliances which may be used for offshore operations the following is to be submitted for approval purposes:

(a) the maximum sea state in which the lifting appliance is to be used

(b) the worst case vertical and horizontal accelerations

(c) the worst case wind loadings for the specified design sea state and wind environment.

The load scenario to be examined is to account for these environmental loads. As a minimum, the following load scenario is to be examined:

(a) 150% of the Safe Working Load added to the lifting appliances self weight.

When a crane cab is fitted above the slewing ring, the load scenario is to be specially considered.

3.1.4.20 The vertical reaction force and maximum overturning moment, corresponding to the design loads specified in **3.1.4.18** and **3.1.4.19**, are to be calculated and used in the assessment of the structure.

3.1.4.21 The stresses induced in the supporting structure are not to exceed the permissible values given below, based on the gross thickness of the structure:

Normal stress $0.67 \sigma_{yd}$

Shear stress $0.39 \sigma_{yd}$

Where:

σ_{yd} : specified minimum yield stress of the material, in N/mm^2

Normal stress is the sum of bending stress and axial stress with the corresponding shearing stress acting perpendicular to the normal stress.

3.1.4.22 The capability of the supporting structure to resist buckling failure is also to be assured.

3.1.5 Supporting structures for components used in emergency towing arrangements on tankers

3.1.5.1 Tankers having a deadweight of greater than or equal to 20000tonnes are to be fitted with an emergency towing arrangement at both ends, complying with *Maritime Safety Committee Resolution MSC 35(63)*.

3.1.5.2 The Safe Working Load of emergency towing arrangements is as specified in *IMO Resolution MSC 35(63)*, as follows:

(a) 1000kN for vessels having a deadweight greater than or equal to 20000tonnes, but less than 50000tonnes

(b) 2000kN for vessels having a deadweight greater than or equal to 50000tonnes.

3.1.5.3 The following plans are to be submitted for approval:

(a) details of the supporting structure for the emergency towing arrangement, including the connection to the deck.

3.1.5.4 The following supporting information is also to be submitted:

(a) details of the emergency towing arrangement showing sufficient detail to enable the position and direction of load actions to be ascertained.

3.1.5.5 The deck in way of strong-points and fairleads is to have a minimum gross thickness of 15mm.

3.1.5.6 The structural arrangement is to provide continuity of strength.

3.1.5.7 The structural arrangement of the ship's structure in way of the emergency towing equipment is to be such that, abrupt changes of shape or section are to be avoided in order to minimise stress concentrations. Sharp corners and notches are to be avoided, especially in high stress areas.

3.1.5.8 The scantlings of the support structure are to be dimensioned to ensure that for the load cases specified in **3.1.5.10** and **3.1.5.11**, the calculated stresses in the support structure do not exceed the permissible stress levels specified in **3.1.5.12**.

3.1.5.9 These requirements are to be assessed using a simplified engineering analysis based on elastic beam theory, two-dimensional grillage or finite-element analysis using gross scantlings.

3.1.5.10 The design load for the connection of the strong-point and fittings to the deck and its supporting structure is to be taken as twice the Safe Working Load.

3.1.5.11 The assessment of the structure is to consider lines of action of the applied design load, taking into account the particular arrangements proposed. See *IMO MSC 35(63)*.

3.1.5.12 For the design load specified in **3.1.5.10** and **3.1.5.11** the stresses induced in the supporting structure and welds, in way of strong-points and fairleads, are not to exceed the permissible values given below based on the gross thickness of the structure:

Normal stress $1.00 \sigma_{yd}$

Shear stress $0.58 \sigma_{yd}$

Where:

σ_{yd} : specified minimum yield stress of the material, in N/mm^2

Normal stress is the sum of bending stress and axial stress with the corresponding shearing stress acting perpendicular to the normal stress.

3.1.5.13 The capability of the structure to resist buckling failure is also to be assured.

3.1.6 Supporting structure for bollards and bitts, fairleads, stand rollers, chocks and capstans

3.1.6.1 In general, shipboard fittings (bollards and bitts, fairleads, stand rollers and chocks) and capstans used for mooring, and towing (other than as specified in **3.1.5**) of the vessel are to be fitted to the deck or bulwark structures using a purpose designed base or attachment.

3.1.6.2 The attachment of shipboard fittings to sheer strakes or sheer strake upstands is to be avoided, as required by **Sections 8/2.2.5.2** and **Section 8/2.2.5.3**.

3.1.6.3 Where fairleads are fitted in bulwarks and the imposed loads from mooring or towing lines are high, the thickness of bulwarks may need to be increased. See also **2.1.2**.

3.1.6.4 The following plans are to be submitted for approval:

- (a) details of the supporting structure for the shipboard fitting and capstan arrangements, including the connection of shipboard fittings and their seats to the deck.

3.1.6.5 The following supporting information is also to be submitted:

- (a) details of the shipboard fittings and capstans including the Safe Working Load of shipboard fittings and arrangements showing sufficient detail to enable the position and direction of load actions to be ascertained.

3.1.6.6 The structural arrangement is to provide continuity of strength.

3.1.6.7 The structural arrangement of the ship's structure in way of the shipboard fittings and their seats and in way of capstans is to be such that, abrupt changes of shape or section are to be avoided in order to minimise stress concentrations. Sharp corners and notches are to be avoided, especially in high stress areas.

3.1.6.8 The scantlings of the support structure are to be dimensioned to ensure that for the loads specified in **3.1.6.10**, **3.1.6.11** and **3.1.6.12**, the calculated stresses in the support structure do not exceed the permissible stress levels specified in **3.1.6.13**.

3.1.6.9 These requirements are to be assessed using a simplified engineering analysis based on elastic beam theory, two-dimensional grillage or finite-element analysis using net scantlings. The required gross thickness is obtained by adding the relevant full corrosion addition specified in **Section 6/3** to the required net thickness.

3.1.6.10 The design load for the connection of shipboard fittings and their seats to the deck and its supporting structure is to be based on the line load as the greater of the following requirements, as applicable for the particular fitting and its intended use:

- (a) in the case of normal towing in harbour or manoeuvring operations, 125% of the maximum towline load as indicated on the towing and mooring arrangement plan, or
- (b) in the case of towing service other than that experienced in harbour or manoeuvring operations, such as escort service, the nominal breaking strength of towline according to **Table 11.4.2** for the ship's corresponding equipment number, or
- (c) in the case of mooring operations 125% of the nominal breaking strength of the mooring line (hawser) or towline according to **Table 11.4.2** for the ship's corresponding equipment number.

3.1.6.11 The design load for the supporting structure for capstans is to be based the following:

- (a) 125% of the maximum hauling in force.

3.1.6.12 The assessment of the structure is to consider lines of action of the applied design load, taking into account the particular arrangements proposed, however, the total load applied for towing and mooring scenarios described in **3.1.6.10** need not be more than twice the design load on the mooring line or towline. The acting point for the force on the shipboard fittings is to be taken as the attachment point of the mooring line or towline, or at a change in its direction.

3.1.6.13 For the design load specified in **3.1.6.10**, **3.1.6.11** and **3.1.6.12** the stresses induced in the supporting structure and welds are not to exceed the permissible values given below based on the net thickness of the structure. The required gross thickness is obtained by adding the relevant full corrosion addition specified in **Section 6/3** to the required net thickness.

Normal stress 1.00 σ_{yd}

Shear stress 0.60 σ_{yd}

Where:

σ_{yd} : specified minimum yield stress of the material, in N/mm^2

Normal stress is the sum of bending stress and axial stress with the corresponding shearing stress acting perpendicular to the normal stress.

3.1.6.14 The capability of the structure to resist buckling failure is also to be assured.

3.1.6.15 The following requirements on Safe Working Load apply for a single post basis (no more than one turn of one cable).

- (a) The Safe Working Load used for normal towing operations (e.g., harbour/manoeuvring) is not to exceed 80% of the design load per **3.1.6.10.(a)** and the Safe Working Load used for other towing operations (e.g., escort) is not to exceed the design load per **3.1.6.10.(b)**. For deck fittings used for both normal and other towing operations, the greater of the design loads of **3.1.6.10.(a)** and **3.1.6.10.(b)** is to be used.
- (b) The Safe Working Load for mooring operations is not to exceed 80% of the design load per **3.1.6.10.(c)**.
- (c) The Safe Working Load of each deck fitting is to be marked (by weld bead or equivalent) on the deck fittings used for towing and/or mooring.
- (d) The towing and mooring arrangements plan mentioned in **3.1.6.16** is to define the method of use of towing lines and/or mooring lines.

3.1.6.16 The Safe Working Load for the intended use for each deck fitting is to be noted in the towing and mooring arrangements plan available on board for the guidance of the Master. Information provided on the plan is to include in respect of each deck fitting:

- (a) Location on the ship;
- (b) Fitting type;
- (c) SWL;
- (d) Purpose (mooring/harbor towing/escort towing); and
- (e) Manner of applying towing or mooring line load including limiting fleet angles.

This information is to be incorporated into the pilot card in order to provide the pilot proper information on harbour/escorting operations.

3.1.7 Supporting structures for other deck equipment or fittings which are subject to specific approval

3.1.7.1 The following requirements relate to other items of deck equipment which are not covered by **3.1.2** to **3.1.6**. The scantlings and arrangements of support structure for such items are to be in accordance with the following requirements and the additional requirements of the Society.

3.1.7.2 The support structure of items not mentioned in this sub-section will be independently considered by the Society.

3.1.7.3 The following details are to be submitted for approval. They may be indicated separately or may be included on the main structural drawings:

- (a) plans showing the supporting structure for deck equipment/fittings
- (b) details of the loads imposed on the structure by the deck equipment/fittings.

3.1.7.4 The support structure is to be arranged in order to resist both in-plane and out-of-plane loads acting on the deck structure.

3.1.7.5 Support for lifting appliances for personnel is to be provided as follows:

- (a) in general, lifesaving appliances (lifeboats, life-rafts and rescue boats) are to be stowed on a purpose built cradle, seat or deployment appliance. The design load imposed on the ship structure is to be established by the supplier of the lifesaving appliance
- (b) the support structure is to be adequate for the design loads. Local stiffening and a local increase in plating thickness is to be provided. Deep supporting members may be required. Additional National and International Regulations are to be applied, where applicable
- (c) support structure for crew lifts is to be provided in way of the anchor points of lift operating equipment
- (d) support structure for boarding (accommodation) ladders is to be provided in way of the anchor points of accommodation ladders.

3.1.7.6 Support for mast structures fitted with navigation aids is to be provided as follows:

- (a) adequate primary support members for the mast are to be arranged in the form of bulkheads, deep beams or girders. Such members are to be arranged below or close to the mast structure
- (b) in order to transmit the loads from the mast structure to the primary support members, under-deck stiffening members are to be arranged below the mast structure forming the attachment of the mast to the deck
- (c) the deck thickness may be required to be increased to provide an adequate thickness for the weld attachments.

3.1.7.7 Supporting structure for breakwaters is to be designed to withstand the same design load as the breakwater itself. It is to be suitable for transmitting the loads from the breakwater into the primary support members of the ship. Efficient under-deck stiffening is to be provided in way of the breakwater structure that forms the deck connection.

3.1.8 Support and attachment of miscellaneous deck fittings which are not subject to specific approval

3.1.8.1 The following general requirements are to be considered in the design of the support and attachment of miscellaneous fittings which impose relatively small loads on the ship's structure and are not subject to specific approval. The arrangements of such details do not require the approval of plans by the Society.

3.1.8.2 Support positions are to be arranged so that the attachment to the ship structure is clear of deck openings and stress concentrations, such as the toes of end brackets. Design of supports is to be such that the attachment to the deck minimises the creation of hard points.

3.1.8.3 A cargo manifold support is a self-contained, fabricated assembly designed to support the main pipework used for loading and unloading the ship. The design of the cargo manifold support is to be such as to distribute the loads imposed on the pipework during loading and unloading into the ship structure. To achieve this, the connection of the cargo manifold support to the deck is normally to be arranged to align with stiffening members of the main hull structure. Where this is impracticable, additional stiffening is to be fitted in order to avoid the creation of hard points. Attention is to be paid to the detail design of the structure forming the deck attachment in order to minimise the effects of change of section.

3.2 Docking**3.2.1 Docking arrangements**

3.2.1.1 The drydocking arrangement itself is not covered explicitly in this Part.

3.2.1.2 The structure of bottom girders is to be sufficiently stiffened to withstand the forces imposed by drydocking the ship.

3.2.1.3 For ships of unusual form, or where the Owner of the vessel has specific requirements for docking strength, the builder may need to carry out additional calculations. Such calculations are outside of the scope of Classification, but may be reviewed upon request.

3.2.2 Docking plan

3.2.2.1 It is recommended that consideration be given to providing a docking plan for a vessel. The docking plan is to indicate any and all assumptions made during the design, including but not limited to, the arrangement of docking blocks, the maximum permissible loading during docking and the corresponding load at each block.

3.2.2.2 The docking plan does not require approval by the Society as a condition of Classification.

Guidance Note:

1. It is recommended that bottom plugs are not fitted in way of the keel plate.

3.3 Bilge Keels**3.3.1 Construction and materials**

3.3.1.1 The bilge keel is to be of the same material tensile properties as the bilge strake to which it is attached.

3.3.1.2 Bilge keels of a different design, from that shown in **Fig. 11.3.4**, will be specially considered.

3.3.1.3 A plan of all bilge keels is to be submitted for the approval of the material strength and grades, welded connections and detail design.

3.3.1.4 The design of single web bilge keels is to ensure that failure to the web occurs before failure of the ground bar. In general, this may be achieved by ensuring the web thickness of the bilge keel does not exceed that of the ground bar.

3.3.2 Ground bars

3.3.2.1 Bilge keels, where fitted, are to be attached to the shell by a ground bar, or doubler, as shown in **Fig. 11.3.4** and **11.3.5**. In general, the ground bar is to be continuous.

3.3.2.2 The gross thickness of the ground bar is not to be less than the gross thickness of the bilge strake or 14mm, whichever is the lesser.

3.3.2.3 The ground bar is to be of the same material strength as the bilge strake to which it is attached and constructed of the steel grade given in **Section 6/1.2, Tables 6.1.2 and 6.1.3** for bilge strakes.

3.3.3 End details

3.3.3.1 The ends of the bilge keel are to be suitably tapered and are to terminate on an internal stiffening member. Typical arrangements complying with the requirements of this subsection are shown in **Fig. 11.3.5**. Alternative end arrangements will be accepted, provided that they are considered equivalent.

3.3.3.2 The ground bar and bilge keel ends are to be tapered or rounded. Where the ends are tapered, the tapers are to be gradual with a minimum ratio of 3:1. See **Fig. 11.3.5(a)**, **11.3.5(b)**, **11.3.5(d)** and **11.3.5(e)**. Where the ends are rounded, details are to be as shown in **Fig. 11.3.5(c)**. Cut outs on the bilge keel web, within zone ‘A’, see **Fig. 11.3.5(b)** and **11.3.5(e)**, are not permitted.

3.3.3.3 The end of the bilge keel web is to be not less than 50mm and not greater than 100mm from the end of the ground bar. See **Fig. 11.3.5(a)** and **11.3.5(d)**.

3.3.3.4 An internal transverse support member is to be positioned between the end of the bilge keel web and the halfway point between the end of the bilge keel web and the end of the ground bar. See **Fig. 11.3.5(a)**, **11.3.5(b)** and **11.3.5(c)**.

3.3.3.5 Where an internal longitudinal stiffener is fitted in line with the bilge keel web, the longitudinal stiffener is to extend to at least the nearest transverse member forward and aft of zone ‘A’. See **Fig. 11.3.5(b)** and **11.3.5(e)**. In this case, the requirement in **3.3.3.4** relating to the internal transverse support does not apply.

3.3.4 Welding

3.3.4.1 The ground bar is to be connected to the shell with a continuous fillet weld, and the bilge keel to the ground bar with a light continuous fillet weld, in accordance with **Table 11.3.1**.

3.3.4.2 Butt welds, in the bilge keel and ground bar, are to be well clear of each other and of butts in the shell plating. In general, shell butts are to be flush in way of the ground bar and ground bar butts are to be flush in way of the bilge keel. Direct connection between ground bar butt welds and shell plating, and between bilge keel butt welds and ground bar is to be avoided.

3.3.4.3 In general, scallops and cut-outs are not to be used. Crack arresting holes are to be drilled in the bilge keel butt welds as close as practicable to the ground bar. The diameter of hole is to be greater than the width of the butt weld and is to be a minimum of 25mm in diameter, as illustrated in **Fig. 11.3.4**. Where the butt weld has been subject to non-destructive examination, the crack arresting hole may be omitted.

3.3.4.4 Welds at the end of the ground bar and shell plating, and at the end of the bilge keel web and ground bar connection, within Zone ‘B’, see **Fig. 11.3.5(a)** and **11.3.5(d)** are to have a throat thickness as given in **Table 11.3.1** for “At ends”. The toes of these welds are to be ground to blend them smoothly with the base materials.

Table 11.3.1 Welding Requirements for End Connections of Bilge Keels

Structural items being joined	Throat thickness, in mm	
	At ends	Elsewhere
Ground bar to shell	0.44 t_{grs}	0.34 t_{grs}
Bilge keel web to ground bar	0.34 t_{grs}	0.21 t_{grs}

Where:

t_{grs} : gross thickness of the item being attached, in mm

Fig. 11.3.4 Bilge Keel Construction

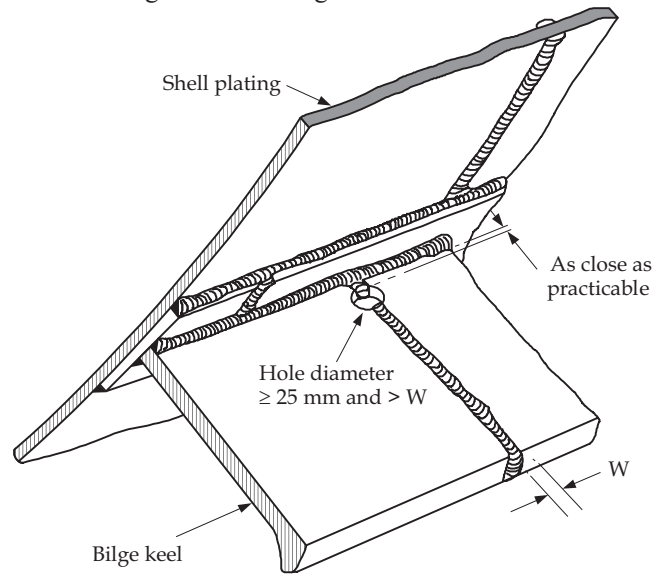

Fig. 11.3.5 (a) – (c) Bilge Keel End Design

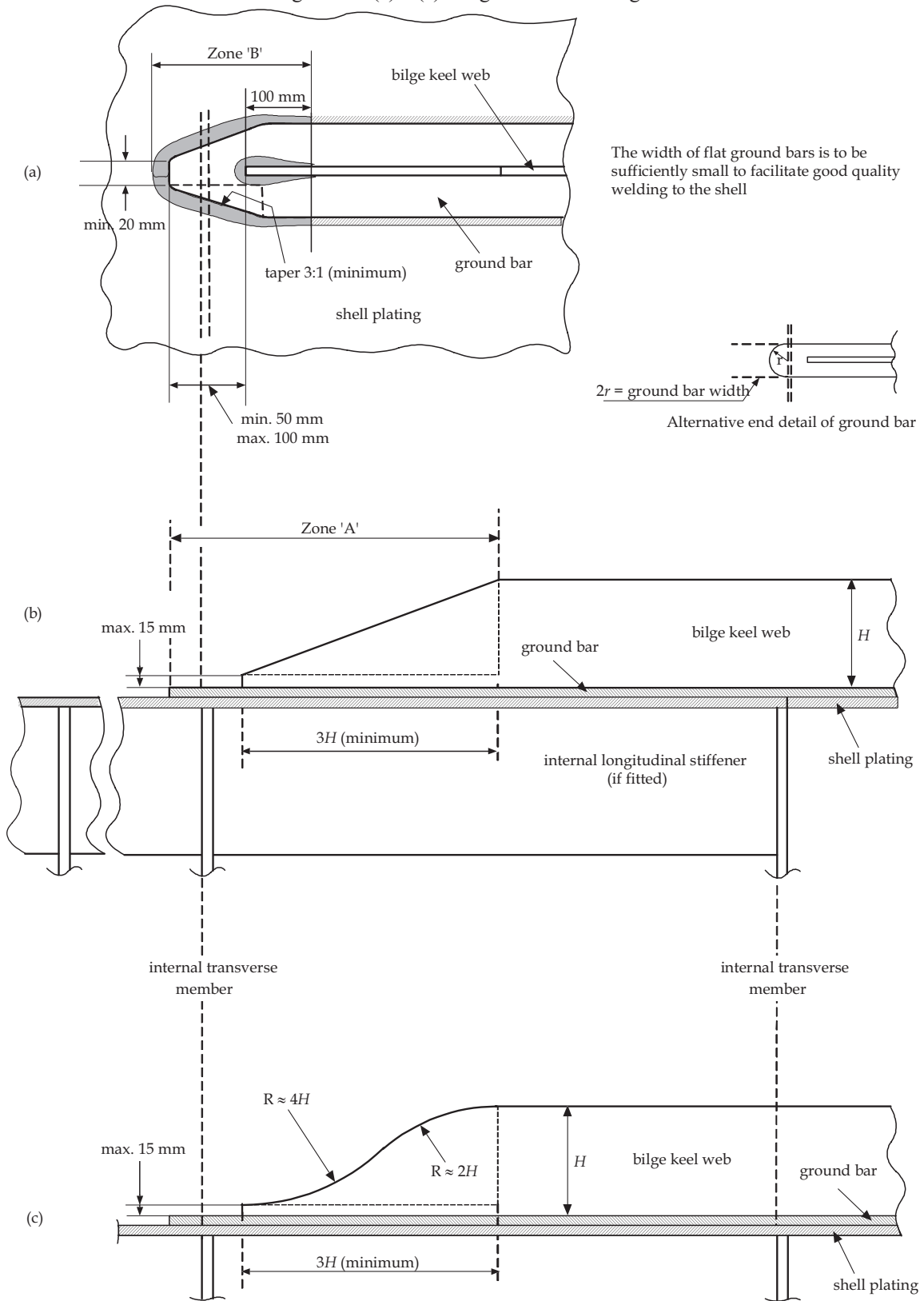
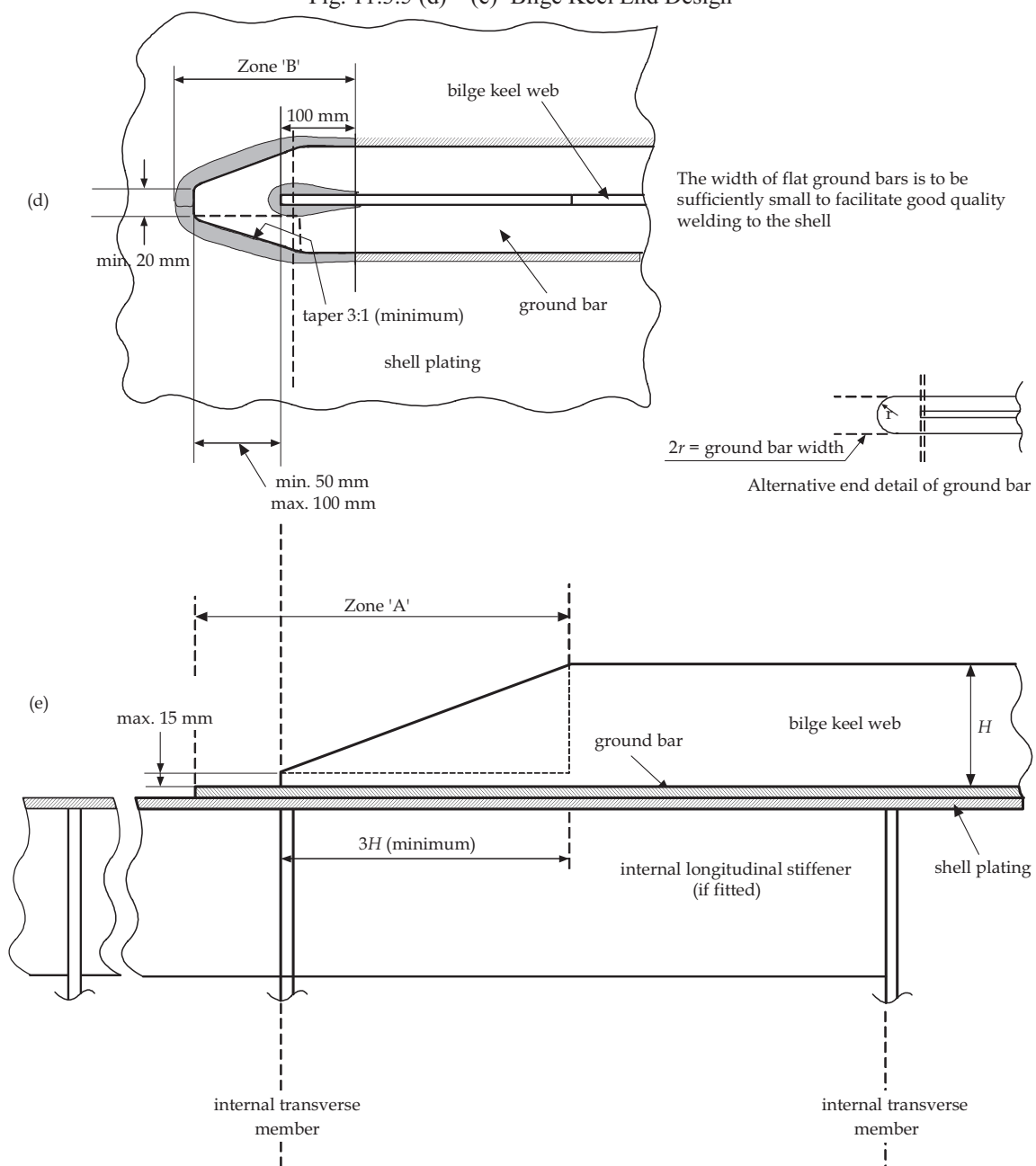

Fig. 11.3.5 (d) – (e) Bilge Keel End Design



4. Equipment

4.1 Equipment Number Calculation

4.1.1 Requirements

4.1.1.1 Anchors and chains are to be in accordance with **Table 11.4.1** and the quantity, mass and sizes of these are to be determined by the equipment number (EN), given by:

$$EN = \Delta^{2/3} + 2Bh_{dk} + 0.1A$$

Where:

Δ : moulded displacement, in *tonnes*, as defined in **Section 4/1.1.7.1**

B : moulded breadth, in *m*, as defined in **Section 4/1.1.3.1**

h_{dk} : $h_{FB} + h_1 + h_2 + h_3 + \dots$, as shown in **Fig. 11.4.1**. In the calculation of h , sheer, camber and trim may be neglected

h_{FB} : freeboard from the summer load waterline amidships, in *m*

h_1, h_2, \dots : height on the centreline of each tier of houses having a breadth greater than $B/4$, in *m*

$h_3 \dots h_n$

A : profile area of the hull, superstructure and houses above the summer load waterline which are within the length L_{CSR-T} , in m^2 . Superstructures or deck houses having a breadth equal to or less than $B/4$ at any point may be excluded. With regard to determining A , when a screen or bulwark is more than 1.5*m* high, the area shown in **Fig. 11.4.2** as A_2 is to be included in A

L_{CSR-T} : rule length, as defined in **Section 4/1.1.1.1**

Note :

- Screens or Screens or bulwarks 1.5*m* or more in height are to be regarded as parts of houses when determining h and A .
- If a house having a breadth greater than $B/4$ is above a house with a breadth of $B/4$ or less then the wide house is to be included but the narrow house ignored.

Fig. 11.4.1 Effective Heights of Deck Houses

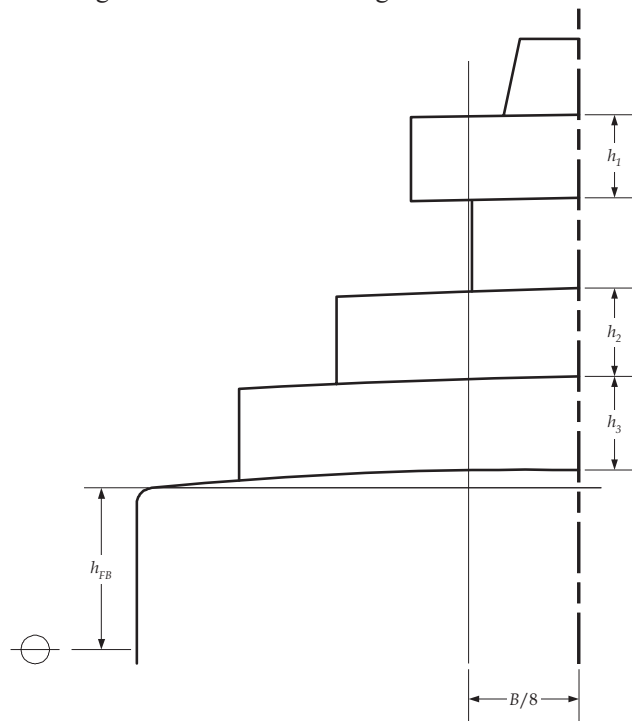
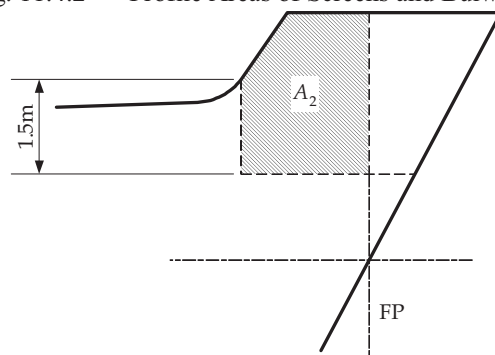

Fig. 11.4.2 Profile Areas of Screens and Bulwarks



4.2 Anchors and Mooring Equipment

4.2.1 General

4.2.1.1 The following anchoring equipment specification is intended for temporary mooring of a vessel within a harbour or sheltered area when the vessel is awaiting berth, tide, etc.

4.2.2 Limitations

4.2.2.1 The equipment specified is not intended to be adequate to hold a ship off fully exposed coasts in rough weather or to stop a ship that is moving or drifting. In such a condition, the loads on the anchoring equipment increase to such a degree that its components may be damaged or lost.

4.2.2.2 The anchoring equipment specified is intended to hold a ship in good holding ground in conditions such as to avoid dragging of the anchor. In poor holding ground, the ability of the anchors to hold the ship will be significantly reduced.

4.2.3 Assumptions

4.2.3.1 The Equipment Number (*EN*) formula for the required anchoring equipment is based on an assumed current speed of 2.5m/s , wind speed of 25m/s and a scope of chain cable between 6 and 10. The scope of chain cable is defined as the ratio between the length of chain paid out and the waters depth.

4.2.3.2 It is assumed that under normal circumstances a ship will use only one bow anchor and chain cable at a time.

4.2.4 Documentation

4.2.4.1 The following plans and particulars are to be submitted for approval:

- (a) equipment number calculations
- (b) list of equipment including type of anchor, grade of anchor chain, type and breaking load of steel and fibre ropes
- (c) anchor design, if different from standard or previously approved anchor types, including material specification
- (d) windlass design; including material specifications for cable lifters, shafts, couplings and brakes
- (e) chain stopper design and material specification
- (f) emergency towing, towing and mooring arrangement plans and applicable Safe Working Load data, and other information related to emergency towing and mooring arrangements that will be available onboard the ship for the guidance of the Master.

4.2.5 Anchors

4.2.5.1 Two bower anchors are to be connected to chain cable and stowed in position ready for use.

4.2.5.2 A third anchor is recommended to be provided as a spare bower anchor and is listed for guidance only; it is not required as a condition of classification.

4.2.5.3 Anchors are to be of an approved design. The design of anchor heads is to be such as to minimize stress concentrations. In particular, the radii, on all parts of cast anchor heads are to be as large as possible, especially where there is considerable change of section.

4.2.5.4 The mass per anchor of bower anchors given in **Table 11.4.1** is for anchors of equal mass. The mass of individual anchors may vary 7% above or below the tabulated value, provided that the combined mass of all anchors is not less than that required for anchors of equal mass.

4.2.6 Ordinary anchors

4.2.6.1 Anchors are to be of the stockless type. The mass of the head of a stockless anchor, including pins and fittings, is not to be less than 60% of the total mass of the anchor.

4.2.7 High holding power anchors

4.2.7.1 Where agreed by the Owner, consideration will be given to the use of special types of anchors. Where these are of a proven increased holding ability, consideration may also be given to some reduction in the basic requirement of anchor mass, up to a maximum of 25% from the mass specified in **Table 11.4.1**.

4.2.7.2 An anchor for which approval is sought as a high holding power (HHP) anchor is to be tested at sea to show that it has a holding power of twice that approved for a standard stockless anchor of the same mass.

4.2.7.3 If approval is sought for a range of sizes then at least two are to be tested. The smaller of the two anchors is to have a mass not less than one-tenth of that of the larger anchor. The larger of the two anchors tested is to have a mass not less than one-tenth of that of the largest anchor for which approval is sought.

4.2.7.4 Each test is to comprise a comparison between at least two anchors, one ordinary stockless bower anchor and one HHP anchor. The masses of the anchors are to be approximately equal.

4.2.7.5 The tests are to be conducted on at least three different types of bottom, which may be soft mud or silt, sand or gravel, and hard clay or similarly compacted material.

4.2.7.6 The tests are generally to be carried out by means of a tug. The pull is to be measured by a dynamometer or determined from recently verified data of the tug's bollard pull as a function of propeller rpm.

4.2.7.7 The diameter of the chain cables connected to the anchors is to be as required for the relevant Equipment Number. During the test, the length of the chain cable on each anchor is to be sufficient to obtain an approximately horizontal pull on the anchor. Generally, a horizontal distance between anchor and tug equal to 10 *times* the water depth will be sufficient.

4.2.7.8 High holding power anchors are to be of a design that will ensure that the anchors will take effective hold of the sea bed without undue delay and will remain stable, for holding forces up to those required by **4.2.7.2**, irrespective of the angle or position at which they first settle on the sea bed when dropped from a normal type of hawse pipe. A demonstration of these abilities may be required.

4.2.7.9 The design approval of high holding power anchors may be given as a general/type approval, and listed in a published document by the Society.

4.2.8 Chain cables

4.2.8.1 The total length of chain required to be carried onboard, as given in **Table 11.4.1**, is to be divided approximately equally between the two bower anchors.

4.2.8.2 Where the Owner requires equipment for anchoring at depths greater than 82.5m, it is the Owner's responsibility to specify the appropriate total length of the chain cable required. In such a case, consideration can be given to dividing the chain cable into two unequal lengths.

4.2.8.3 Chain cables which are intended to form part of the equipment are not to be used as check chains when the vessel is launched.

4.2.9 Chain lockers

4.2.9.1 The chain locker is to have adequate capacity and be of a suitable form to provide for the proper stowage of the chain cable, allowing an easy direct lead for the cable into the chain pipes when the cable is fully stowed. Port and starboard cables are to have separate spaces.

4.2.9.2 The chain locker boundaries and access openings are to be watertight. Provisions are to be made to minimize the probability of the chain locker being flooded in bad weather. Adequate drainage facilities for the chain locker are to be provided.

4.2.9.3 Chain or spurling pipes are to be of suitable size and provided with chafing lips.

4.2.9.4 Chain lockers fitted aft the collision bulkhead are to be watertight and the space is to be efficiently drained.

4.2.10 Securing and emergency release of chain cable

4.2.10.1 Provisions are to be made for securing the inboard ends of the chain to the structure. This attachment is to be able to withstand a force of not less than 15% or more than 30% of the minimum breaking strength of the as fitted chain cable. The structure to which it is attached is to be adequate for this load.

4.2.10.2 The fastening of the chain to the ship is to be arranged in such a way that in case of an emergency, when the anchor and chain have to be sacrificed, the chain can be readily released from an accessible position outside the chain locker. The proposed arrangement for slipping the chain cable must be made as watertight as possible.

4.2.11 Chain stoppers

4.2.11.1 Means are to be provided to secure each chain cable once it is paid out. This is normally achieved by means of chain stoppers.

4.2.11.2 Securing arrangements of chain stoppers are to be capable of withstanding a load equal to 80% of the breaking load of the chain cable as required by **4.2.8**, without undergoing permanent deformation.

4.2.12 Tests

4.2.12.1 All anchors and chain cables are to be tested at establishments and on machines recognised by the Society, under the supervision of Surveyors or other Representatives of the Society and in accordance with **Chapter 2** and **Chapter 3, Part L** of the Rules.

4.2.12.2 Test certificates showing particulars of weights of anchors, or size and weight of cable and of the test loads applied are to be available. These certificates are to be examined by the Surveyor when the anchors and cables are placed onboard the ship.

4.2.12.3 Steel wire and fibre ropes are to be tested in accordance with **Chapter 4** and **Chapter 5, Part L** of the Rules.

4.2.13 Mooring lines and toelines

4.2.13.1 Except as indicated in **4.3**, mooring lines and toelines are not required as a condition of Classification. The hawsers and toelines listed in **Table 11.4.2** are intended as a guide. Where the tabular breaking strength is greater than $490kN$, the breaking strength and the number of individual hawsers given in the Table may be modified, provided that their product is not less than that of the breaking strength and the number of hawsers given in the Table.

4.2.14 Increased number or strength of mooring lines

4.2.14.1 On a ship regularly using exposed berths, it is recommended that the total strength of mooring lines is twice that indicated in **4.2.13.1**.

4.2.14.2 Attention is also drawn to the Oil Companies International Marine Forum document, *Mooring Equipment Guidelines*, for guidance on mooring of tankers at exposed locations.

4.2.15 Alternative mooring arrangement

4.2.15.1 For ease of handling, fibre ropes should not to be less than $20mm$ in diameter.

4.2.15.2 All ropes having breaking strengths greater than $736kN$ and used in normal mooring operations should be handled by, and stored on, suitably designed winches. Alternative methods of storing are to give due consideration to the difficulties experienced in manually handling ropes having breaking strengths in excess of $490kN$. In such cases, the breaking strength and the number of individual hawsers given in **Table 11.4.2** may be modified, but their product is not to be less than that of the breaking strength and the number of hawsers given in the Table. However, the number of mooring lines is not to be less than six, and no line should have a breaking strength less than $490kN$.

4.2.16 Securing mooring lines

4.2.16.1 Means should be provided to enable mooring lines to be adequately secured onboard ship. It is recommended that the total number of suitably placed bollards on either side of the ship and/or the total brake holding power of mooring winches is to be capable of holding not less than 1.5 times the sum of the maximum breaking strengths of the mooring lines.

4.2.17 Bollards and bitts, fairleads, stand rollers and chocks

4.2.17.1 The strength of shipboard fittings used for normal and/or emergency operations at bow, sides and stern are to comply with the requirements of **4.2.17.2** and **4.2.17.3**. The requirements for the support structure of these shipboard fittings are specified in **3.1.6**.

4.2.17.2 Shipboard fittings are to be designed and constructed in accordance with recognized standards (e.g. ISO3913 Shipbuilding Welded Steel Bollards). The design load used to assess shipboard fittings and their attachments to the hull are to be in accordance with **3.1.6**.

4.2.17.3 The following requirements on Safe Working Load (SWL) apply to shipboard fittings used for mooring and/or emergency towing:

- (a) the SWL is not to exceed 80% of the design load specified in **3.1.6.10(a)** and **3.1.6.10(c)** or 100% of the design load specified in **3.1.6.10(b)**, as applicable
- (b) the SWL of each fitting is to be marked by weld bead or equivalent
- (c) the SWL with its intended use, i.e., mooring, towing or emergency towing operations or some combination thereof, for each fitting is to be indicated in the towing/emergency towing and mooring arrangement plans available onboard the ship for the guidance of the Master. The arrangement plans or information is to include information on each fitting detailing location on the ship, fitting type, Safe Working Load, purpose, method of applying load and limiting fleet angle, and it is to explicitly prohibit the use of mooring and/or towing lines outside of their intended function and/or different characteristics
- (d) the requirements of this paragraph apply for a single post basis (no more than one turn of one cable).

4.2.18 Mooring winches

4.2.18.1 Mooring winch design and capacity are not subject to approval by the Society as a condition of Classification. Mooring winch plans and information are to be submitted for approval of the supporting structure in way of the winch and for the connection of the mooring winch to its foundation and the connection of the foundation to the deck, as required by **3.1.3**.

Guidance Note:

Mooring winches should be fitted with drum brakes, the strength of which is to be sufficient to prevent unreeling of the mooring line when the rope tension is equal to 80 percent of that for a rope with breaking strength equal to the greater of the maximum breaking strength of the rope specified on the mooring arrangement plan or that according to **Table 11.4.2** for the ship's corresponding equipment number, as fitted on the first layer on the winch drum.

4.2.19 Windlass

4.2.19.1 A windlass of sufficient power and suitable for the size of chain is to be fitted to the ship in accordance with **Chapter 16, Part D** of the Rules. Where an Owner requires equipment significantly in excess of Rule requirements, it is the Owner's responsibility to specify increased windlass power.

4.2.19.2 The windlass is to be capable of heaving in either cable.

4.2.19.3 The design of the windlass is to be such that access to the chain pipe is adequate to permit the fitting of a cover or seal of sufficient strength over the sperling pipe.

Special consideration will be given to the acceptance of equivalent arrangements that minimize the probability of the chain locker or forecabin being flooded in bad weather.

4.2.20 Anchor windlass trial

4.2.20.1 Each windlass is to be tested under working conditions after installation onboard to demonstrate satisfactory operation. Each unit is to be independently tested for the following:

- (a) braking
- (b) clutch functioning
- (c) lowering and hoisting of chain cable and anchor
- (d) proper riding of the chain over the chain lifter
- (e) proper transit of the chain through the hawse pipe and the chain pipe
- (f) effecting proper stowage of the chain and the anchor.

4.2.20.2 During trials onboard ship, the windlass is to be shown to:

- (a) for all specified design anchorage depths, raise the anchor from a depth of 82.5m to a depth of 27.5m at a mean speed of 9m/min
- (b) for specified design anchorage depths greater than 82.5m, in addition to (a), raise the anchor from the specified design anchorage depth to a depth of 82.5m at a mean speed of 3m/min.

Where the depth of the water in the trial area is inadequate, suitable equivalent simulating conditions will be considered as an alternative.

4.2.21 Stowage and deployment arrangements for anchors

4.2.21.1 Arrangements are to be provided to ensure the simple deployment, recovery and stowage of anchors. Such arrangements generally consist of a hawse pipe and anchor housing which may be in the form of a fabricated anchor box or pocket.

4.2.21.2 Where hawse pipes are not fitted, alternative arrangements will be specially considered.

4.2.22 Dimensions and scantlings of hawse pipes and anchor pockets

4.2.22.1 Hawse pipes are to be of a suitable size and configuration to ensure adequate clearance and an easy lead of the chain cable from the chain stopper through the ship's side.

4.2.22.2 Hawse pipes are to be of sufficient strength.

4.2.22.3 Anchor pockets are to be of substantial thickness and of a suitable size and form to house the anchors efficiently, preventing, as much as practicable, slackening of the cable or movements of the anchor, caused by wave action.

4.2.22.4 Hawse pipes and anchor pockets are to have full-rounded flanges or rubbing bars in order to minimize the nip on the cables and to minimize the probability of cable links being subjected to high bending stresses. The radius of curvature is to be such that at least three links of chain will bear simultaneously on the rounded parts of the upper and lower ends of the hawse pipes in those areas where the chain cable is supported during paying out and hoisting and when the vessel is at anchor.

4.2.23 Hull reinforcement

4.2.23.1 Hawse pipes are to be securely attached to thick, doubling or insert plates, by continuous welds.

4.2.23.2 Framing in way of hawse pipes or anchor pockets is to be reinforced as necessary to ensure a rigid fastening to the hull.

4.2.23.3 On ships provided with a bulbous bow, where it is not possible to obtain a suitable clearance between shell plating and the anchors during anchor handling, local reinforcements of the bulbous bow are to be provided in the form of increased shell plate thickness.

4.2.24 Testing

4.2.24.1 The anchors are to be shipped and unshipped so that the Surveyor is satisfied that there is no risk of the anchor jamming in the hawse pipe.

4.2.24.2 During the windlass trials at sea, the Surveyor is to be satisfied that upon release of the brake, the anchor immediately starts falling by its own weight.

4.2.24.3 When in position, hawse pipes and anchor pockets are to be thoroughly tested for watertightness by means of a hose in which the water pressure is in accordance with the requirements given in **Sub-section 5**.

Table 11.4.1 Equipment – Bower Anchors and Chain Cables

Equipment Number		Stockless bower anchors		Chain cable stud link bower chain diameter			
		Number of anchors	Mass per anchor, in <i>kg</i>	Length, in <i>m</i>	Normal strength steel (Grade 1), in <i>mm</i>	Higher strength steel (Grade 2), in <i>mm</i>	Extra higher strength steel (Grade 3), in <i>mm</i>
greater than or equal to	less than						
150	175	2	480	275	22	19	
175	205	2	570	302.5	24	20.5	
205	240	2	660	302.5	26	22	20.5
240	280	2	780	330	28	24	22
280	320	2	900	357.5	30	26	24
320	360	2	1020	357.5	32	28	24
360	400	2	1140	385	34	30	26
400	450	2	1290	385	36	32	28
450	500	2	1440	412.5	38	34	30
500	550	2	1590	412.5	40	34	30
550	600	2	1740	440	42	36	32
600	660	2	1920	440	44	38	34
660	720	2	2100	440	46	40	36
720	780	2	2280	467.5	48	42	36
780	840	2	2460	467.5	50	44	38
840	910	2	2640	467.5	52	46	40
910	980	2	2850	495	54	48	42
980	1060	2	3060	495	56	50	44
1060	1140	2	3300	495	58	50	46
1140	1220	2	3540	522.5	60	52	46
1220	1300	2	3780	522.5	62	54	48
1300	1390	2	4050	522.5	64	56	50
1390	1480	2	4320	550	66	58	50
1480	1570	2	4590	550	68	60	52
1570	1670	2	4890	550	70	62	54
1670	1790	2	5250	577.5	73	64	56
1790	1930	2	5610	577.5	76	66	58
1930	2080	2	6000	577.5	78	68	60
2080	2230	2	6450	605	81	70	62
2230	2380	2	6900	605	84	73	64
2380	2530	2	7350	605	87	76	66
2530	2700	2	7800	632.5	90	78	68
2700	2870	2	8300	632.5	92	81	70
2870	3040	2	8700	632.5	95	84	73
3040	3210	2	9300	660	97	84	76

Table 11.4.1 (Continued) Equipment – Bower Anchors and Chain Cables

Equipment Number		Stockless bower anchors		Chain cable stud link bower chain diameter			
		Number of anchors	Mass per anchor, in <i>kg</i>	Length, in <i>m</i>	Normal strength steel (Grade 1), in <i>mm</i>	Higher strength steel (Grade 2), in <i>mm</i>	Extra higher strength steel (Grade 3), in <i>mm</i>
greater than or equal to	less than						
3210	3400	2	9900	660	100	87	78
3400	3600	2	10500	660	102	90	78
3600	3800	2	11100	687.5	105	92	81
3800	4000	2	11700	687.5	107	95	84
4000	4200	2	12300	687.5	111	97	87
4200	4400	2	12900	715	114	100	87
4400	4600	2	13500	715	117	102	90
4600	4800	2	14100	715	120	105	92
4800	5000	2	14700	742.5	122	107	95
5000	5200	2	15400	742.5	124	111	97
5200	5500	2	16100	742.5	127	111	97
5500	5800	2	16900	742.5	130	114	100
5800	6100	2	17800	742.5	132	117	102
6100	6500	2	18800	742.5	*	120	107
6500	6900	2	20000	770	*	124	111
6900	7400	2	21500	770	*	127	114
7400	7900	2	23000	770	*	132	117
7900	8400	2	24500	770	*	137	122
8400	8900	2	26000	770	*	142	127
8900	9400	2	27500	770	*	147	132
9400	10000	2	29000	770	*	152	132
10000	10700	2	31000	770	*	*	137
10700	11500	2	33000	770	*	*	142
11500	12400	2	35500	770	*	*	147
12400	13400	2	38500	770	*	*	152
13400	14600	2	42000	770	*	*	157
14600	16000	2	46000	770	*	*	162

Note :

Spare anchors are not included in the number of required anchors.

‘*’ chain grade not to be used at this diameter.

Table 11.4.2 Equipment - Towline and Hawsers

Equipment Number		Towline wire or rope		Hawsers		
		Length, in <i>m</i>	Breaking strength, in <i>kN</i>	Number	Length of each, in <i>m</i>	Breaking strength, in <i>kN</i>
greater than or equal to	less than					
150	175	180	98.0	3	120	54.0
175	205	180	112.0	3	120	59.0
205	240	180	129.0	4	120	64.0
240	280	180	150.0	4	120	69.0
280	320	180	174.0	4	140	74.0
320	360	180	207.0	4	140	78.0
360	400	180	224.0	4	140	88.0
400	450	180	250.0	4	140	98.0
450	500	180	277.0	4	140	108.0
500	550	190	306.0	4	160	123.0
550	600	190	338.0	4	160	132.0
600	660	190	371.0	4	160	147.0
660	720	190	406.0	4	160	157.0
720	780	190	441.0	4	170	172.0
780	840	190	480.0	4	170	186.0
840	910	190	518.0	4	170	201.0
910	980	190	559.0	4	170	216.0
980	1060	200	603.0	4	180	230.0
1060	1140	200	647.0	4	180	250.0
1140	1220	200	691.0	4	180	270.0
1220	1300	200	738.0	4	180	284.0
1300	1390	200	786.0	4	180	309.0
1390	1480	200	836.0	4	180	324.0
1480	1570	220	888.0	5	190	324.0
1570	1670	220	941.0	5	190	333.0
1670	1790	220	1024.0	5	190	353.0
1790	1930	220	1109.0	5	190	378.0
1930	2080	220	1168.0	5	190	402.0
2080	2230	240	1259.0	5	200	422.0
2230	2380	240	1356.0	5	200	451.0
2380	2530	240	1453.0	5	200	480.0
2530	2700	260	1471.0	6	200	480.0
2700	2870	260	1471.0	6	200	490.0
2870	3040	260	1471.0	6	200	500.0
3040	3210	280	1471.0	6	200	520.0
3210	3400	280	1471.0	6	200	554.0
3400	3600	280	1471.0	6	200	588.0
3600	3800	300	1471.0	6	200	618.0
3800	4000	300	1471.0	6	200	647.0
4000	4200	300	1471.0	7	200	647.0
4200	4400	300	1471.0	7	200	657.0
4400	4600	300	1471.0	7	200	667.0
4600	4800	300	1471.0	7	200	677.0
4800	5000	300	1471.0	7	200	686.0

Table 11.4.2 (Continued) Equipment - Towline and Hawsers

Equipment Number		Towline wire or rope		Hawsers		
		Length, in <i>m</i>	Breaking strength, in <i>kN</i>	Number	Length of each, in <i>m</i>	Breaking Strength, in <i>kN</i>
greater than or equal to	less than					
5000	5200	300	1471.0	8	200	686.0
5200	5500	300	1471.0	8	200	696.0
5500	5800	300	1471.0	8	200	706.0
5800	6100	300	1471.0	8	200	706.0
6100	6500	300	1471.0	9	200	716.0
6500	6900	300	1471.0	9	200	726.0
6900	7400	300	1471.0	10	200	726.0
7400	7900	300	1471.0	11	200	726.0
7900	8400	300	1471.0	11	200	735.0
8400	8900	300	1471.0	12	200	735.0
8900	9400	300	1471.0	13	200	735.0
9400	10000	300	1471.0	14	200	735.0
10000	10700	-	-	15	200	735.0
10700	11500	-	-	16	200	735.0
11500	12400	-	-	17	200	735.0
12400	13400	-	-	18	200	735.0
13400	14600	-	-	19	200	735.0
14600	16000	-	-	21	200	735.0

4.3 Emergency Towing

4.3.1 General requirements

4.3.1.1 Emergency towing arrangements are to be fitted at both the bow and stern of every tanker with a deadweight of 20000 *tonnes* or more, as required by the *International Convention for the Safety of Life at Sea, 1974, as amended (Regulation II-1/3-4)*.

4.3.1.2 The design and construction of the towing arrangements is to be approved by the applicable Flag Administration, based on *IMO MSC.35(63), Guidelines for Emergency Towing Arrangements on Tankers*. See also **3.1.5** for requirements relating to the support structure of emergency towing equipment.

5. Testing Procedures

5.1 Tank Testing

5.1.1 Application

5.1.1.1 The following tanks and boundaries are to be tested in accordance with the requirements given in **5.1.3** to **5.1.9**, as follows:

- (a) gravity tanks, excluding independent tanks of less than $5m^3$ in capacity, for their structural adequacy and tightness
- (b) watertight boundaries, other than tank boundaries, for watertightness
- (c) weathertight boundaries for weathertightness.

5.1.2 Definitions

5.1.2.1 Watertight means capable of preventing the passage of water through the structure under a head of water for which the surrounding structure is designed.

5.1.2.2 Weathertight means that in any sea conditions water will not penetrate into the ship.

5.1.2.3 Structural Testing is a hydrostatic test carried out in order to demonstrate structural adequacy of the design. Where severe practical limitations prevail and hydrostatic testing is not feasible, hydropneumatic testing may be carried out instead.

5.1.2.4 Leak Testing is an air or other medium test, carried out in order to demonstrate the tightness of the structure.

5.1.2.5 Hose Testing is carried out by a jet of water in order to demonstrate the tightness of the structure items which are not subjected to hydrostatic or leak testing, and to other components which contribute to the watertight or weathertight integrity of the hull.

5.1.2.6 Hydropneumatic Testing is a combination of hydrostatic and air testing, undertaken by filling the tank with water and applying an additional air pressure. It is carried out in order to demonstrate the tightness of the tanks and the structural adequacy of the design as an alternative to a hydrostatic test.

5.1.2.7 Hydrostatic Testing is a test to verify the structural adequacy of the design and the tightness of the tank's structure by means of water pressure, produced by filling water to the level given in **Table 11.5.1**. Hydrostatic testing is the normal means for structural testing, with exception, where severe practical limitations prevent it or where air testing is permitted.

5.1.2.8 Shop Primer is a thin coating applied after surface preparation and prior to fabrication as a protection against corrosion during fabrication.

5.1.2.9 Protective Coating is the coating system applied to protect the structure from corrosion. This excludes the shop primer.

5.1.3 Test procedures

5.1.3.1 Tests are to be carried out in the presence of, and to the satisfaction of the Surveyor. The construction is to be at a stage sufficiently close to completion, after all attachments, outfittings or penetrations, which may affect the strength or tightness of the structure, have been completed, such that the strength and tightness are not subsequently impaired, and before any ceiling and cement work is applied over joints.

5.1.3.2 Specific test requirements are given in **Table 11.5.1**.

5.1.3.3 For the timing of the application of coating in relation to testing, see **5.1.8**.

5.1.4 Structural testing

5.1.4.1 Where structural testing is specified by **Table 11.5.1**, hydrostatic testing will be acceptable, except where practical limitations prevent it or where leak testing is permitted by **Note 1** to **Table 11.5.1**. Hydropneumatic testing may be approved in lieu of hydrostatic testing.

5.1.4.2 Hydrostatic testing is to consist of a head of water to the level specified in **Table 11.5.1**.

5.1.4.3 Hydropneumatic testing, where approved, is to simulate the actual loading as far as practicable in relation to the combined water level and air pressure. The requirements and recommendations in **5.1.5** relative to air pressure will also apply.

5.1.4.4 Structural testing may be carried out afloat where testing using water is undesirable in dry dock or on the building berth. When structural testing is carried out afloat it is to be performed by filling each tank and cofferdam separately to the test head given in **Table 11.5.1**.

5.1.4.5 With about half the number of tanks full, the bottom and lower side shell in the empty tanks is to be examined and the remainder of the lower side shell is to be examined when the water has been transferred to the remaining tanks.

5.1.4.6 Tank boundaries are to be tested from at least from one side. Tanks to be tested for structural adequacy (see **Note 1** to **Table 11.5.1**) are to be selected so that all representative structural members are tested for the expected tension and compression.

5.1.5 Leak testing

5.1.5.1 All boundary welds, erection joints, and penetrations including pipe connections, except welds made by automatic processes are to be examined in accordance with the approved procedure and under a pressure of at least 0.15bar with a leak indicating solution (e.g. soapy water solution). Pressures greater than 0.20bar are not recommended.

5.1.5.2 It is recommended that the air pressure in the tank be raised to and maintained at 0.20bar for approximately one hour, with a minimum number of personnel around the tank, before being lowered to the test pressure.

5.1.5.3 A U-tube filled with water up to a height corresponding to the required test pressure is to be fitted for verification and to avoid over pressure. The cross sectional area of the U-tube is to be not less than that of the pipe supplying the air. In addition to the U-tube, a master gauge or other approved means is to be provided to verify the pressure.

5.1.5.4 Other effective methods of leak testing, including compressed air fillet weld testing or vacuum testing may be considered upon submission of full particulars.

5.1.6 Hose testing

5.1.6.1 Hose testing is applied to structures not subjected to structural or air testing but that are required to be watertight or weathertight as specified in **Table 11.5.1**.

5.1.6.2 Hose testing is to be carried out with a pressure in the hose of at least 2.0 bar for the duration of the test. The nozzle is to have minimum inside diameter of 12mm and is to be directed at the joint being tested from a distance not exceeding 1.5m.

5.1.6.3 Leak testing or structural testing may be accepted in lieu of hose testing.

5.1.7 Other methods of testing

5.1.7.1 Other methods of testing may be considered upon submission of the full particulars.

5.1.8 Application of coating – protective coating

5.1.8.1 Final coating may be applied prior to the hydrostatic testing provided that leak testing is carried out before the application of the final coating.

5.1.8.2 The cause of any discolouration or disturbance of the coating is to be ascertained, and any deficiencies repaired.

5.1.8.3 For all manual or semi-automatic erection welds, and all fillet weld tank boundary connections, including penetrations, final coating is to be applied after leak testing has taken place. For other welds, the final coating may be applied prior to leak testing, provided the Surveyor, after careful examination prior to the application of coating, is satisfied with the weld. The Surveyor may require leak testing to be carried out prior to final coating of automatic erection welds and manual or automatic pre-erection welds, taking account of the quality control procedure of the shipyard.

5.1.8.4 Final coating is to be applied after all required hose testing is completed.

5.1.9 Temporary coating

5.1.9.1 Temporary coatings which may conceal defects or leaks are to be applied as specified for protective coating, see **5.1.8**. This requirement does not apply to shop primer applied before fabrication.

5.1.9.2 Silicate based shop primer may be applied to welds before leak testing. The layer of the primer is to be applied with a maximum thickness of 50 microns. Other primers of uncertain chemical composition are to be applied with a maximum thickness of 30 microns.

Table 11.5.1 Testing Requirements for Tanks and Boundaries

	Structures to be tested	Type of testing	Hydrostatic testing head or pressure	Remarks
1	Double Bottom Tanks	Structural ⁽¹⁾	The greater of - to the top of overflow, or - to the bulkhead deck	Tank boundaries tested from at least one side
2	Double Side Tanks	Structural ⁽¹⁾	The greater of - to the top of overflow, or - to 2.4m above top of tank ⁽²⁾	Tank boundaries tested from at least one side
3	Cargo Tanks	Structural ⁽¹⁾	The greatest of - to the top of overflow, - to 2.4m above top of tank ⁽²⁾ , or - to the top of tank ⁽²⁾ plus setting of any pressure relief valve	Tank boundaries tested from at least one side
	Fuel Oil Bunkers	Structural ⁽¹⁾		
4	Cofferdams	Structural ⁽³⁾	The greater of - to the top of overflow, or - to 2.4m above top of cofferdam	
5a	Peak Tanks	Structural	The greater of - to the top of overflow, or - to 2.4m above top of tank ⁽²⁾	Aft peak tank test to be carried out after installation of stern tube.
5b	Fore Peak not used as a tank	Refer to <i>SOLAS II.1 Reg.14</i>		
5c	Aft Peak not used as a tank	Leak		
6	Watertight Bulkheads in way of dry space	Hose ⁽⁴⁾		Including steps and recesses
7	Watertight Doors below freeboard or bulkhead deck	Hose		For testing before installation ⁽⁵⁾
8	(void)			
9	Watertight hatch covers of tanks on combination carriers	Structural testing	The greater of: - to 2.4m above the top of hatch cover, or - setting pressure of the pressure relief valve	At least every second hatch cover is to be tested
10	Weather-tight Hatch Covers, Doors and other Closing Appliances	Hose ⁽⁴⁾		
11	Shell plating in way of pump room	Visual examination		To be carefully examined with the vessel afloat
12	Chain Locker (aft Collision Bulkhead)	Structural	To the top of chain locker spurling pipe	
13	Independent Tanks	Structural	The greater of - to the top of overflow, or - to 0.9 m above top of tank	
14	Ballast Ducts	Structural	Ballast pump maximum pressure or setting of any relief valve for the ballast duct if that is less	
15	Hawse Pipes	Hose		

Notes :

1. Leak or hydropneumatic testing may be accepted under the conditions specified in **5.1.5**, provided that at least one tank for each type is structurally tested, and selected in connection with the approval of the design. In general, the structural testing need not be repeated for subsequent vessels of a series of identical new buildings unless the Surveyor deems the repetition necessary. The structural testing of cargo space boundaries and tanks for segregated cargoes or pollutants on subsequent vessels of a series of identical new buildings are to be in accordance with the requirements of the Society.
2. Top of tank is defined as the deck forming the top of the tank excluding hatchways.
3. Leak testing in accordance with **5.1.5** may be accepted, except that hydropneumatic testing may be required in consideration of the construction techniques and welding procedures employed.
4. Where hose testing is impractical due to the stage of outfitting (machinery, cables, switchboard, insulation etc.), it may be replaced at the Society's discretion, by a careful visual examination of all the crossings and welded joints. A dye penetrant test, leak test or ultrasonic leak test may be required.
5. Before installation (i.e. normally at manufacture) the watertight access doors or hatches are to be hydrostatically tested with a head of water equivalent to the bulkhead deck at centre, from the side which is most prone to leakage. The acceptance criteria are as follows:
 - no leakage for doors or hatches with gaskets
 - a maximum water leakage of one litre per minute for doors or hatches with metallic sealing.
6. If leak or hydropneumatic testing is carried out, arrangements are to be made to ensure that no pressure in excess of 0.30 *bar* is applied.

Section 12 SHIP IN OPERATION RENEWAL CRITERIA

1. Allowable Thickness Diminution for Hull Structure

1.1 General

1.1.1 Applicability

1.1.1.1 The purpose of this Section is to provide criteria for the allowable thickness diminution of the ships' hull structure.

1.1.1.2 The criteria apply only to ships in operation that are designed and built in accordance with this part.

1.1.1.3 Thickness measurements are to be used to assess the ships' structure against the specified renewal criteria.

1.1.2 Wastage allowance concept

1.1.2.1 Wastage allowance is comprised of two aspects; local wastage allowance and overall hull girder wastage allowance. Local wastage allowance is defined in **1.4** and the overall hull girder wastage allowance is defined in **1.5**.

1.1.2.2 Assessment against both local and overall hull girder wastage criteria is required during the operational life of the vessel.

1.1.2.3 Steel renewal is required if either the local or overall hull girder wastage allowance is exceeded.

1.1.2.4 The newbuilding requirements within this part incorporates corrosion additions, see **Section 6/3**, and consider all relevant loads and failure modes (e.g. yielding, buckling, and fatigue). No further assessment of the scantlings against the requirements within this part is required during the operational life of the ship provided that the thickness of any structural member remains greater than the renewal thickness specified herein.

1.1.3 Requirements for documentation

1.1.3.1 The plans to be supplied onboard the ship, see **Section 3/2.2.3**, are to include both the as-built and renewal thickness as defined in **1.4.2**. Any owner's extra thickness is also to be clearly indicated on the drawings.

1.1.3.2 The "as-built" Midship Section plan provided by the builder and carried on board the ship is to include a table showing the minimum allowable hull girder sectional properties, as defined in **1.5**, for the mid-tank transverse section in all cargo tanks.

1.2 Assessment of Thickness Measurements

1.2.1 General

1.2.1.1 The minimum survey requirements for the maintenance of class of double hull oil tankers are defined in **Part B** of the Rules.

1.2.1.2 Thickness measurements are to be conducted in accordance with **5.2.6, Part B** of the Rules.

1.2.2 Assessment of local wastage

1.2.2.1 Thickness measurements are to be taken to confirm that the measured thickness is not less than the renewal thickness for general corrosion and local pitting/edge corrosion as defined in **1.4.2** and **1.6** respectively. See also **1.3**.

1.2.2.2 When a survey identifies that steel renewal is required or structural defects are present which, in the opinion of the Surveyor, will impair the ships' fitness for continued service, remedial measures are to be implemented before the ship continues in service.

1.2.2.3 Re-examination and additional thickness measurements at Annual and Intermediate Surveys are required where the measured thickness, t_m , is less than the allowable thickness at annual survey, t_{annual} , defined as:

$$t_{annual} = t_{as-built} - t_{own} - t_{was} \quad (mm)$$

Where:

$t_{as-built}$: as built thickness, in *mm*

t_{was} : wastage allowance, as defined in **1.4.2.2**

t_{own} : owner/builder specified additional wastage allowance, if applicable, in *mm*

1.2.2.4 Where re-examination and additional thickness measurements are required by 1.2.2.3 then additional measurements are to be carried out in accordance with **Table 12.1.1** to determine the full extent of the corrosion pattern.

Table 12.1.1 Additional Thickness Measurement in way of Structure Identified with $t_m < t_{annual}$

Structural member	Extent of measurement	Pattern of measurement
Plating	Suspect areas and adjacent plates	5 point pattern over $1m^2$
Stiffeners	Suspect areas	3 measurements in line across web 3 measurements in line across flange

1.2.2.5 At each Special Survey, thickness measurements are to be taken in way of critical areas, as considered necessary by the Surveyor. Critical areas are to include locations throughout the ship with corrosion levels that are likely to contravene 1.2.2.3 and/or are considered prone to rapid wastage.

1.2.3 Assessment of overall hull girder wastage

1.2.3.1 The hull girder sectional properties of the ship are to be calculated for the cross-sections as specified in **Part B** of the Rules, based on the thicknesses given by the thickness measurements, to confirm that the resulting hull girder sectional properties are not less than the minimum allowable defined in 1.5.2. The actual sectional properties calculated based on measured thicknesses and in accordance with **Part B** of the Rules, are to be submitted to the Society.

1.3 Categories of Corrosion

1.3.1 General corrosion

1.3.1.1 General corrosion is defined as areas where general uniform reduction of material thickness is found over an extensive area.

1.3.1.2 Renewal criteria for general corrosion are given in 1.4.

1.3.2 Pitting corrosion

1.3.2.1 Pitting corrosion is defined as scattered corrosion spots/areas with local material reductions which are greater than the general corrosion in the surrounding area.

1.3.2.2 The pitting intensity is defined in **Fig. 12.1.1**.

1.3.2.3 Renewal criteria for pitting corrosion are given in 1.6.2.

1.3.3 Edge corrosion

1.3.3.1 Edge corrosion is defined as local corrosion at the free edges of plates, stiffeners, primary support members and around openings. An example of edge corrosion is shown in **Fig. 12.1.2**.

1.3.3.2 Renewal criteria for edge corrosion are given in 1.6.3.

1.3.4 Groove corrosion

1.3.4.1 Groove corrosion is typically local material loss adjacent to weld joints along abutting stiffeners and at stiffener or plate butts or seams. An example of groove corrosion is shown in **Fig. 12.1.3**.

1.3.4.2 Renewal criteria for groove corrosion are given in 1.6.4.

Fig. 12.1.1 Pitting Intensity Diagrams

5% Scattered

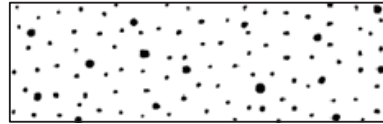

10% Scattered

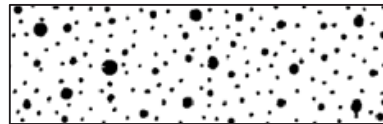

20% Scattered

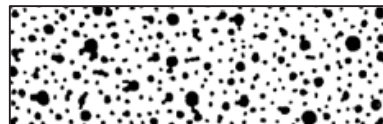

30% Scattered

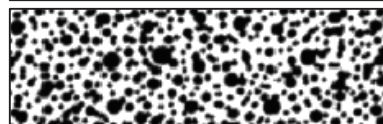

50% Scattered



Fig. 12.1.2 Edge Corrosion

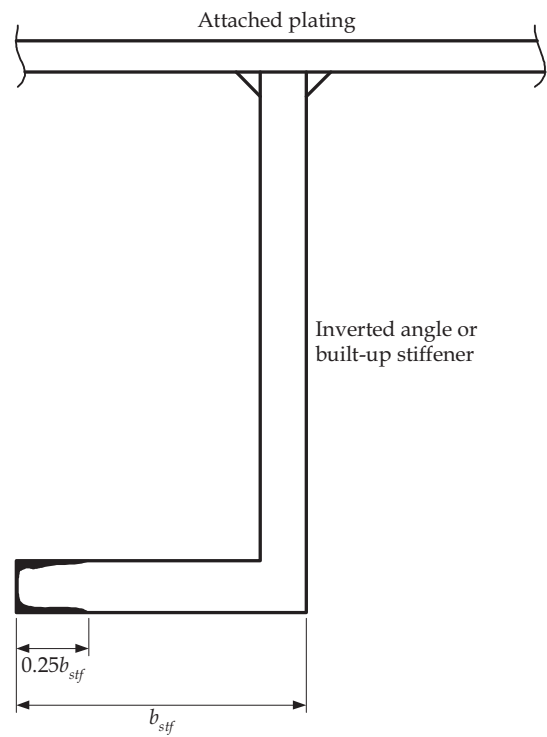
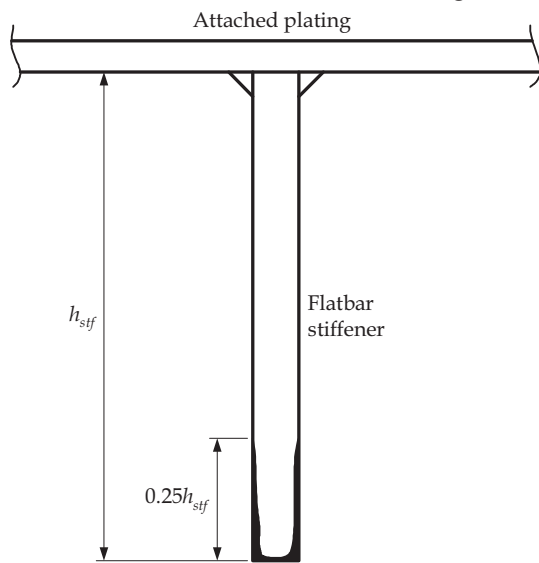

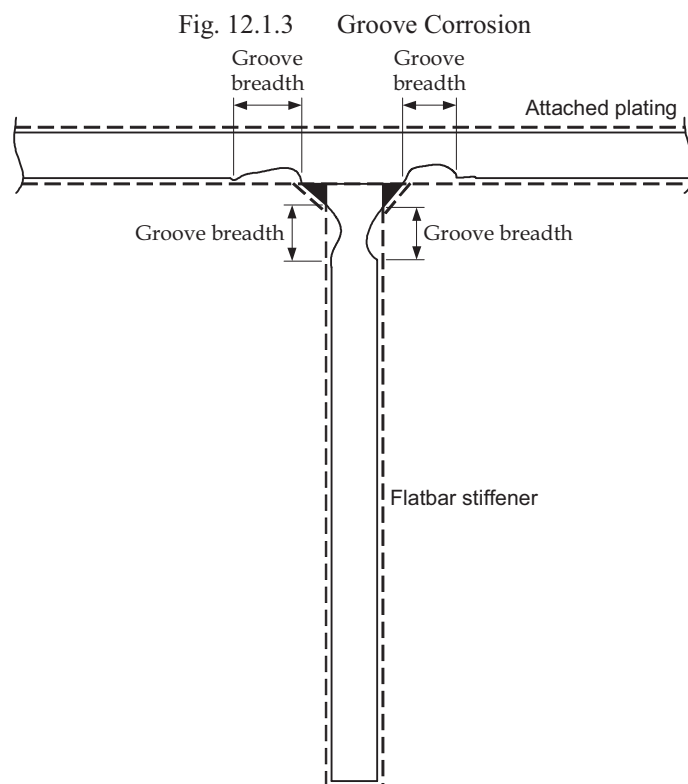

1.4 Renewal Criteria of Local Structure for General Corrosion

1.4.1 Application

1.4.1.1 The renewal criteria in 1.4.2 generally apply to areas of structural members with general corrosion.

1.4.2 Renewal criteria

1.4.2.1 Steel renewal is required if the measured thickness, t_{im} , is less than the renewal thickness, t_{ren} , defined as:

$$t_{ren} = t_{as-built} - t_{was} - t_{own} - t_{corr-2.5} \quad (mm)$$

Where:

$t_{as-built}$: as built thickness, in mm

t_{was} : wastage allowance, as defined in 1.4.2.2

t_{own} : owner/builder specified additional wastage allowance, if applicable, in mm

$t_{corr-2.5}$: 0.5 mm , wastage allowance in reserve for corrosion occurring in the two and a half years between Intermediate and Special surveys

1.4.2.2 The wastage allowance, t_{was} , is given by:

$$t_{was} = t_{was-1} + t_{was-2} \quad (mm) \quad \text{and rounded up to the nearest } 0.5mm$$

Where:

t_{was} : total wastage allowance of the considered structural member, in mm

t_{was-1} : wastage allowance for side one of the structural member considering the contents of the compartment to which it is exposed, in mm , as given **Table 12.1.2**

t_{was-2} : wastage allowance for side two of the structural member considering the contents of the compartment to which it is exposed, in mm , as given **Table 12.1.2**

1.4.2.3 In no case is the wastage allowance, t_{was} , to be less than 1.5 mm , except in way of internals of dry spaces and pump room where 1.0 mm is applicable.

1.4.2.4 Wastage allowances for compartments not listed in **Table 12.1.2** will be subject to special consideration.

1.4.2.5 Areas which need to be renewed based on the renewal criteria in 1.4.2.1 are, in general, to be repaired with inserted material which is to have the same or greater grade/strength as the original and to have a thickness, t_{repair} , not less than:

$$t_{repair} = t_{as-built} - t_{own} \quad (mm)$$

Where:

$t_{as-built}$: as built thickness, in *mm*

t_{own} : owner/builder specified additional wastage allowance, if applicable, in *mm*

Table 12.1.2 Local Wastage Allowance for One Side of Structural Elements

Compartment Type	Structural Member		Ship in Operation Component Wastage Allowance, t_{was-1} or t_{was-2} (<i>mm</i>)
Ballast water tank and chain locker	Face plate of PSM	Within 3 <i>m</i> below top of tank ⁽¹⁾	2.0
		Elsewhere	1.5
	Other members ⁽³⁾	Within 3 <i>m</i> below top of tank ⁽¹⁾	1.7
		Elsewhere	1.2
Cargo oil tank	Face plate of PSM	Within 3 <i>m</i> below top of tank ⁽¹⁾	1.7
		Elsewhere	1.4
	Inner-bottom plating/bottom of tank		2.1
	Other members	Within 3 <i>m</i> below top of tank ⁽¹⁾	1.7
		Elsewhere	1.0
Exposed to atmosphere	Weather deck plating		1.7
	Other members		1.0
Exposed to sea water	Shell plating ⁽²⁾		1.0
Fuel and lube oil tank ⁽⁴⁾	Top of tank and attached internal stiffeners		1.0
	Elsewhere		0.7
Fresh water tank	Top of tank and attached internal stiffeners		1.0
	Elsewhere		0.7
Void spaces	Spaces not normally accessed, e.g. access only via bolted manhole openings, pipe tunnels, etc.		0.7
Dry spaces	Internals of deckhouses, machinery spaces, pump room, store rooms, steering gear space, etc.		0.5

Notes

1. Only applicable to cargo and ballast tanks with weather deck as the tank top.
2. 0.5*mm* to be added for side plating in the quay contact region as defined in **Section 8/Fig. 8.2.2**.
3. 0.5*mm* to be added to the plate surface exposed to ballast for plate boundary between water ballast and heated cargo oil tanks. 0.3*mm* to be added to each surface of the web and face plate of a stiffener in a ballast tank and attached to the boundary between water ballast and heated cargo oil tanks. Heated cargo oil tanks are defined as tank arranged with any form of heating capability (most common type is heating coils).
4. 0.7*mm* to be added for plate boundary between water ballast and heated fuel oil tanks.

1.5 Renewal Criteria of Hull Girder Sectional Properties for General Corrosion

1.5.1 General

1.5.1.1 The following actual hull girder sectional properties are required to be verified, see **1.5.2-3**:

- (a) vertical hull girder moment of inertia, about the horizontal axis, I_v
- (b) hull girder section modulus about the horizontal axis - at deck-at-side, Z_{v-dk}
- (c) hull girder section modulus about the horizontal axis - at keel, Z_{v-kl}
- (d) hull girder section modulus about the vertical axis - at side, Z_{h-side}
- (e) hull girder vertical shear area, A_{v-shr}

1.5.2 Renewal criteria

1.5.2.1 Steel renewal is required if the actual hull girder sectional properties, I_{v-tm} , $Z_{v-tm-dk}$, $Z_{v-tm-kl}$, $Z_{h-tm-side}$, $A_{v-tm-shr}$, calculated using the actual thickness measurements are less than the minimum allowable hull girder sectional properties defined in accordance with **1.5.3**.

1.5.2.2 The actual hull girder sectional properties listed in **1.5.2.1** are to be calculated in accordance with **Section 4/2.6**, using the measured thicknesses.

1.5.2.3 If steel renewal is required due to reduced hull girder sectional properties this is to be done by replacing local corroded structural elements. Any combination of structural elements may be replaced provided that the resulting hull girder sectional properties satisfy **1.5.2.1**. Local structural elements being renewed are to be replaced in accordance with the requirements of **1.4.2.3**.

1.5.3 Calculation of the minimum allowable hull girder sectional properties

1.5.3.1 The minimum allowable hull girder sectional properties listed in **1.5.1.1** are to be calculated in accordance with **Section 4/2.6**, using the thicknesses defined in **1.5.3.2**.

1.5.3.2 The minimum allowable hull girder sectional properties in the corroded condition are calculated using the same corrosion thickness reductions that are used during the newbuilding stage, thus linking the newbuilding and ship in operation criteria. Therefore the calculation of the minimum allowable hull girder sectional properties is to be based on a member thickness, t , given by:

$$t = t_{as-built} - 0.5t_{corr} - t_{own} \quad (mm)$$

Where:

$t_{as-built}$: as built thickness, in mm

t_{corr} : corrosion addition, as defined in **Section 6/3.2**

t_{own} : owner/builder specified additional wastage allowance, if applicable, in mm

1.6 Allowable Material Diminution for Pitting, Grooving and Edge Corrosion

1.6.1 General

1.6.1.1 Steel renewal for pitting, grooving and edge corrosion is required if the measured thickness is less than the criteria defined in **1.6.2**, **1.6.3** and **1.6.4** respectively.

1.6.2 Pitting

1.6.2.1 For plates with pitting intensity less than 20%, see **Fig. 12.1.1**, the measured thickness, t_{tm} , of any individual measurement is to meet the lesser of the following criteria:

$$t_{tm} \geq 0.7(t_{as-built} - t_{own}) \quad (mm)$$

$$t_{tm} \geq t_{ren} - 1 \quad (mm)$$

Where:

$t_{as-built}$: as built thickness of the member, in mm

t_{own} : owner/builder specified additional wastage allowance, if applicable, in mm

t_{ren} : renewal criteria for general corrosion as defined in **1.4.2.1**

1.6.2.2 The average thickness across any cross section in the plating is not to be less than the renewal criteria for general corrosion given in **1.4.2.1**.

1.6.3 Edge corrosion

1.6.3.1 Provided that the overall corroded height of the edge corrosion of the flange, or web in the case of flat bar stiffeners, is less than 25%, see **Fig. 12.1.2**, of the stiffener flange breadth or web height, as applicable, the measured thickness, t_m , is to meet the lesser of the following criteria:

$$t_m \geq 0.7(t_{as-built} - t_{own}) \quad (mm)$$

$$t_m \geq t_{ren} - 1 \quad (mm)$$

Where:

$t_{as-built}$: as built thickness of the member, in *mm*

t_{own} : owner/builder specified additional wastage allowance, if applicable, in *mm*

t_{ren} : renewal criteria for general corrosion as defined in **1.4.2.1**

1.6.3.2 The average measured thickness across the breadth or height of the stiffener is not to be less than that defined in **1.4.2**.

1.6.3.3 Plate edges at openings for manholes, lightening holes etc. may be below the minimum thickness given in **1.4.2** provided that:

- (a) the maximum extent of the reduced plate thickness, below the minimum given in **1.4.2**, from the opening edge is not more than 20% of the smallest dimension of the opening and does not exceed 100mm
- (b) rough or uneven edges may be cropped-back provided that the maximum dimension of the opening is not increased by more than 10%.

1.6.4 Grooving

1.6.4.1 Where the groove breadth is a maximum of 15% of the web height, but not more than 30mm, see **Fig. 12.1.3**, the measured thickness, t_m , in the grooved area is to meet the lesser of the following criteria:

$$t_m \geq 0.75(t_{as-built} - t_{own}) \quad (mm)$$

$$t_m \geq t_{ren} - 0.5 \quad (mm)$$

but is not to be less than

$$t_m = 6 \quad (mm)$$

Where:

$t_{as-built}$: as built thickness of the member, in *mm*

t_{own} : owner/builder specified additional wastage allowance, if applicable, in *mm*

t_{ren} : renewal criteria for general corrosion as defined in **1.4.2.1**

1.6.4.2 Members with areas of grooving greater than those in **1.6.4.1** are to be assessed based on the criteria for general corrosion as defined in **1.4.2** using the average measured thickness across the plating/stiffener.

Appendix A HULL GIRDER ULTIMATE STRENGTH

1. General

1.1 Definitions

1.1.1 Hull girder bending moment capacity

1.1.1.1 The hull girder ultimate bending moment capacity, M_U , is defined as the maximum bending capacity of the hull girder beyond which the hull will collapse. Hull girder failure is controlled by buckling, ultimate strength and yielding of longitudinal structural elements.

1.1.1.2 The sagging hull girder ultimate capacity of a hull girder section, is defined as the maximum value on the static non-linear bending moment-curvature relationship $M-\kappa$, see **Fig. A.1.1**. The curve represents the progressive collapse behaviour of hull girder under vertical bending.

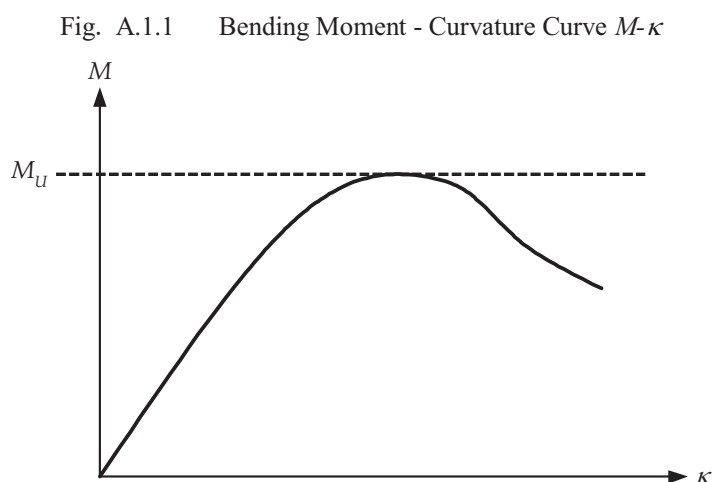

1.1.1.3 The curvature of the critical inter-frame section, κ , is defined as:

$$\kappa = \frac{\theta}{l}$$

Where:

θ : the relative angle rotation of the two neighbouring cross-sections at transverse frame positions

l : the transverse frame spacing, i.e. span of longitudinals

1.2 Application

1.2.1 General

1.2.1.1 The sagging hull girder ultimate bending capacity is to be assessed by the single step method in **2.1** or the incremental-iterative method in **2.2**. This is only applicable to longitudinally framed double hull tankers in the sagging bending condition.

1.2.1.2 The magnitudes of the partial safety factors in **Section 9/1.4** have been calibrated for this single step method in **2.1** and are also appropriate for the incremental iterative method in **2.2**.

1.3 Assumptions

1.3.1 General

1.3.1.1 The method for calculating the ultimate hull girder capacity is to identify the critical failure modes of all main longitudinal structural elements. For tankers, in sagging, the critical mode is generally inter-frame buckling of deck structures, as shown in **Fig. A.1.2**.

1.3.1.2 Structures compressed beyond their buckling limit have reduced load carrying capacity. All relevant failure modes for individual structural elements, such as plate buckling, torsional stiffener buckling, stiffener web buckling, lateral or global stiffener buckling; and their interactions, are to be considered in order to identify the weakest inter-frame failure mode.

1.3.1.3 For tankers in the sagging condition, only vertical bending is considered. The effects of shear force, torsional loading, horizontal bending moment and lateral pressure are neglected.

Fig. A.1.2 Ship in Extreme Sagging Inter-Frame Buckling Failure

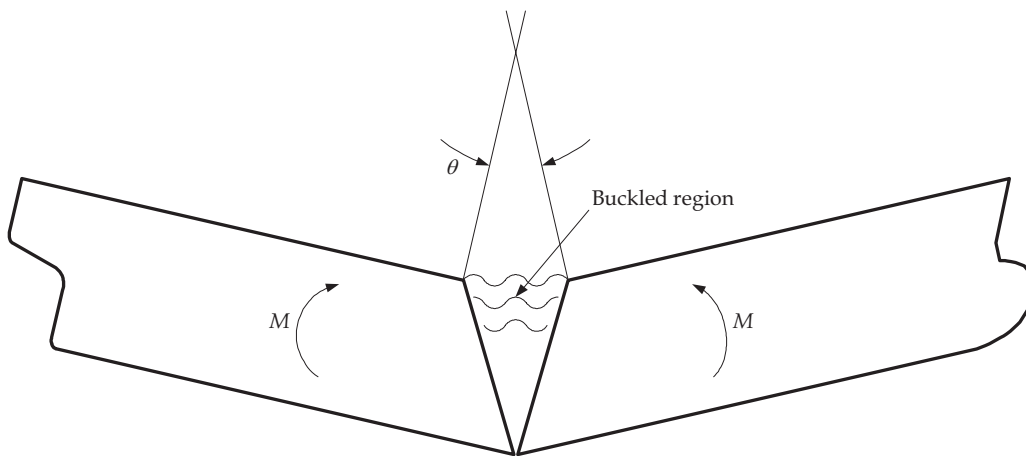

1.4 Alternative Methods

1.4.1 General

1.4.1.1 Principles for alternative methods for the calculation of the hull girder ultimate bending capacity; e.g. incremental-iterative procedure that may differ from the one defined in **2.2**, and non-linear finite element analysis, are given in **Sub-Section 3**.

1.4.1.2 Application of alternative methods is to be agreed with the Society prior to commencement. Documentation of the analysis methodology and detailed comparison of its results with those of the Societies' procedures are to be submitted for review and acceptance. The use of such methods may require the partial safety factors in **Section 9/1.4** to be re-calibrated.

2. Calculation of Hull Girder Ultimate Capacity

2.1 Single Step Ultimate Capacity Method

2.1.1 Procedure

2.1.1.1 The single step procedure for calculation of the sagging hull girder ultimate bending capacity is a simplified method based on a reduced hull girder bending stiffness accounting for buckling of the deck, see **Fig. A.2.1**. The hull girder ultimate bending moment capacity, M_U , is to be taken as:

$$M_U = Z_{red} \sigma_{yd} \cdot 10^3 \quad (kNm)$$

Where:

Z_{red} : reduced section modulus of deck (to the mean deck height)

$$= \frac{I_{red}}{Z_{dk-mean} - Z_{NA-red}} \quad (m^3)$$

I_{red} : reduced hull girder moment of inertia, in m^4 . The inertia is to be calculated in accordance with **Section 4/2.6.1.1**, using

- a hull girder net thickness of t_{net50} for all longitudinally effective members
- the effective net area after buckling of each stiffened panel of the deck, A_{eff}

A_{eff} : effective net area after buckling of the stiffened deck panel. The effective area is the proportion of stiffened deck panel that is effectively able to be stressed to yield

$$= \frac{\sigma_U}{\sigma_{yd}} A_{net50} \quad (m^2)$$

Note :

The effective area of deck girders is to be taken as the net area of the girders using a thickness of t_{net50} .

A_{net50} : net area of the stiffened deck panel, in m^2

σ_U : buckling capacity of stiffened deck panel, in N/mm^2 . To be calculated for each stiffened panel using

- the advanced buckling analysis method, see **Section 10/4** and **Appendix D**
- the net thickness t_{net50}

σ_{yd} : specified minimum yield stress of the material, in N/mm^2 , that is used to determine the hull girder section modulus. In the case of the stiffener and plate having different specified minimum yield stress, σ_{yds} , is to be taken as the lesser of the two.

$Z_{dk-mean}$: vertical distance to the mean deck height, taken as the mean of the deck at side and the deck at centre line, measured from the baseline, in m

Z_{NA-red} : vertical distance to the neutral axis of the reduced section measured from the baseline, in m

2.1.1.2 It is to be shown that the ultimate bending moment capacity, M_U , does not give stresses exceeding the specified minimum yield stress of the material, σ_{yd} , in the bottom shell plating. Therefore the ultimate hull girder bending moment capacity, M_U , is not to be greater than:

$$M_U = \sigma_{yd} \frac{I_{red}}{Z_{NA-red}} \cdot 10^3 \quad (kNm)$$

Where:

σ_{yd} : specified yield stress of material, in N/mm^2

I_{red} : reduced hull girder moment of inertia, as defined in **2.1.1.1**

Z_{NA-red} : vertical distance to the neutral axis of the reduced section measured from the baseline, in m

Fig. A.2.1 Moment – Curvature of Hull Girder Single Step Procedure

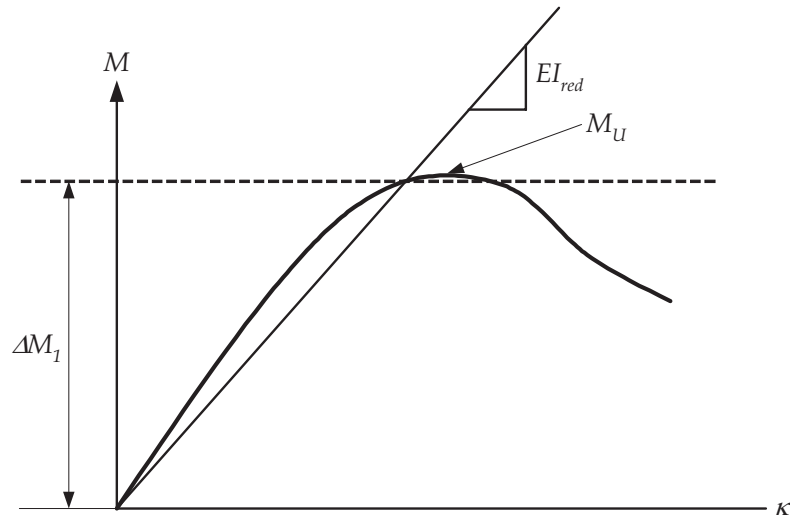

2.1.2 Assumption

2.1.2.1 The assumption behind this procedure is that the ultimate sagging capacity of tankers is the point at which the ultimate capacity of the stiffened deck panels is reached. If the structural configuration is such that this assumption is not valid, then an alternative method to derive the ultimate capacity is to be used.

2.2 Simplified Method Based on an Incremental-iterative Approach

2.2.1 Procedure

2.2.1.1 In this approach, the ultimate hull girder bending moment capacity M_U is defined as the peak value of the curve with vertical bending moment M versus the curvature κ of the ship cross section as shown in **Fig. A.1.1**.

2.2.1.2 The curve M - κ is obtained by means of an incremental-iterative approach; the steps involved in the procedure are given in **2.2.1.7** and illustrated in the flow chart in **Fig. A.2.2**.

2.2.1.3 The bending moment M_i which acts on the hull girder transverse section due to the imposed curvature κ_i is calculated for each step of the incremental procedure. This imposed curvature corresponds to an angle of rotation of the hull girder transverse section about its effective horizontal neutral axis, which induces an axial strain ε in each hull structural element. In the sagging condition, the structural elements below the neutral axis are lengthened, whilst elements above the neutral axis are shortened.

2.2.1.4 The stress σ induced in each structural element by the strain ε is obtained from the stress-strain curve σ - ε of the element, which takes into account the behaviour of the structural element in the non-linear elasto-plastic domain.

2.2.1.5 The force in each structural element is obtained from its area times the stress and these force are summated to derive the total axial force on the transverse section. Note the element area is taken as the total net area of the structural element. This total force may not be zero as the effective neutral axis may have moved due to the non linear response. Hence it is necessary to adjust the neutral axis position, recalculate the element strains, forces and total sectional force and iterate until the total force is zero.

2.2.1.6 Once the position of the new neutral axis is known, then the correct stress distribution in the structural elements is obtained. The bending moment M_i about the new neutral axis due to the imposed curvature κ_i is then obtained by summating the moment contribution given by the force in each structural element.

2.2.1.7 The main steps of the incremental-iterative approach are summarised as follows (see also **Fig. A.2.2**):

- Step 1** Divide the hull girder transverse section into structural elements, ie longitudinal stiffened panels (one stiffener per element), hard corners and transversely stiffened panels, see **2.2.2.2**.
- Step 2** Derive the stress-strain curves (or so called load-end shortening curves) for all structural elements, see **2.3**.
- Step 3** Derive the expected maximum required curvature κ_F , see **2.2.1.8**. The curvature step size $\Delta\kappa$ is to be taken as $\kappa_F/300$. The curvature for the first step, κ_1 is to be taken as $\Delta\kappa$.

Derive the neutral axis z_{NA-i} for the first incremental step ($i=1$) with the value of the elastic hull girder section modulus, $Z_{v-net50}$, see **Section 4/2.6.1**

Step 4 For each element (index j), calculate the strain $\varepsilon_{ij} = \kappa_i (z_j - z_{NA-i})$ corresponding to κ_i , the corresponding stress σ_j , see **2.2.1.9**, and hence the force in the element $\sigma_j A_j$.

Step 5 Determine the new neutral axis position z_{NA-i} by checking the longitudinal force equilibrium over the whole transverse section. Hence adjust z_{NA-i} until

$$F_i = 0.1 \sum A_j \sigma_j \text{ kN} = 0$$

Note :

σ_j is positive for elements under compression and negative for elements under tension. Repeat from step 4 until equilibrium is satisfied. Equilibrium is satisfied when the change in neutral axis position is less than $0.0001m$.

Step 6 Calculate the corresponding moment by summing the force contributions of all elements as follows:

$$M_i = 0.1 \sum \left| \sigma_j A_j (z_j - z_{NA-i}) \right| \quad (kNm)$$

Step 7 Increase the curvature by $\Delta\kappa$, use the current neutral axis position as the initial value for the next curvature increment and repeat from step 4 until the maximum required curvature is reached. The ultimate capacity is the peak value M_u from the $M-\kappa$ curve. If the peak does not occur in the curve, then κ_F is to be increased until the peak is reached

2.2.1.8 The expected maximum required curvature, κ_F , in m^{-1} , for the sagging condition is to be taken as:

$$\kappa_F = 3 \frac{M_{yd}}{EI_{v-net50}} 10^{-3} \quad m^{-1}$$

Where:

M_{yd} : vertical bending moment given by a linear elastic bending stress of yield in the deck or keel. To be taken as the greater of

$$Z_{v-net50-dk} \sigma_{yd} 10^3 \quad (kNm)$$

$$Z_{v-net50-kl} \sigma_{yd} 10^3 \quad (kNm)$$

$Z_{v-net50-dk}$: section modulus at deck or bottom, in m^3 , see **Section 8/1.2.2.3** and

$Z_{v-net50-kl}$ **1.2.2.4**,

E : modulus of elasticity, $2.06 \times 10^5 \text{ (N/mm}^2\text{)}$

σ_{yd} : specified minimum yield stress of the material, in (N/mm^2)

$I_{v-net50}$: hull girder moment of inertia, in m^4 , see **Section 8/1.2.1.1**

2.2.1.9 For each structural element, the stress σ_j corresponding to the element strain ε_{ij} is to be taken as the minimum stress value from all applicable stress-strain curves $\sigma-\varepsilon$ for that element.

Fig A.2.2 Flow Chart of the Procedure for the Evaluation of the Curve $M-\chi$

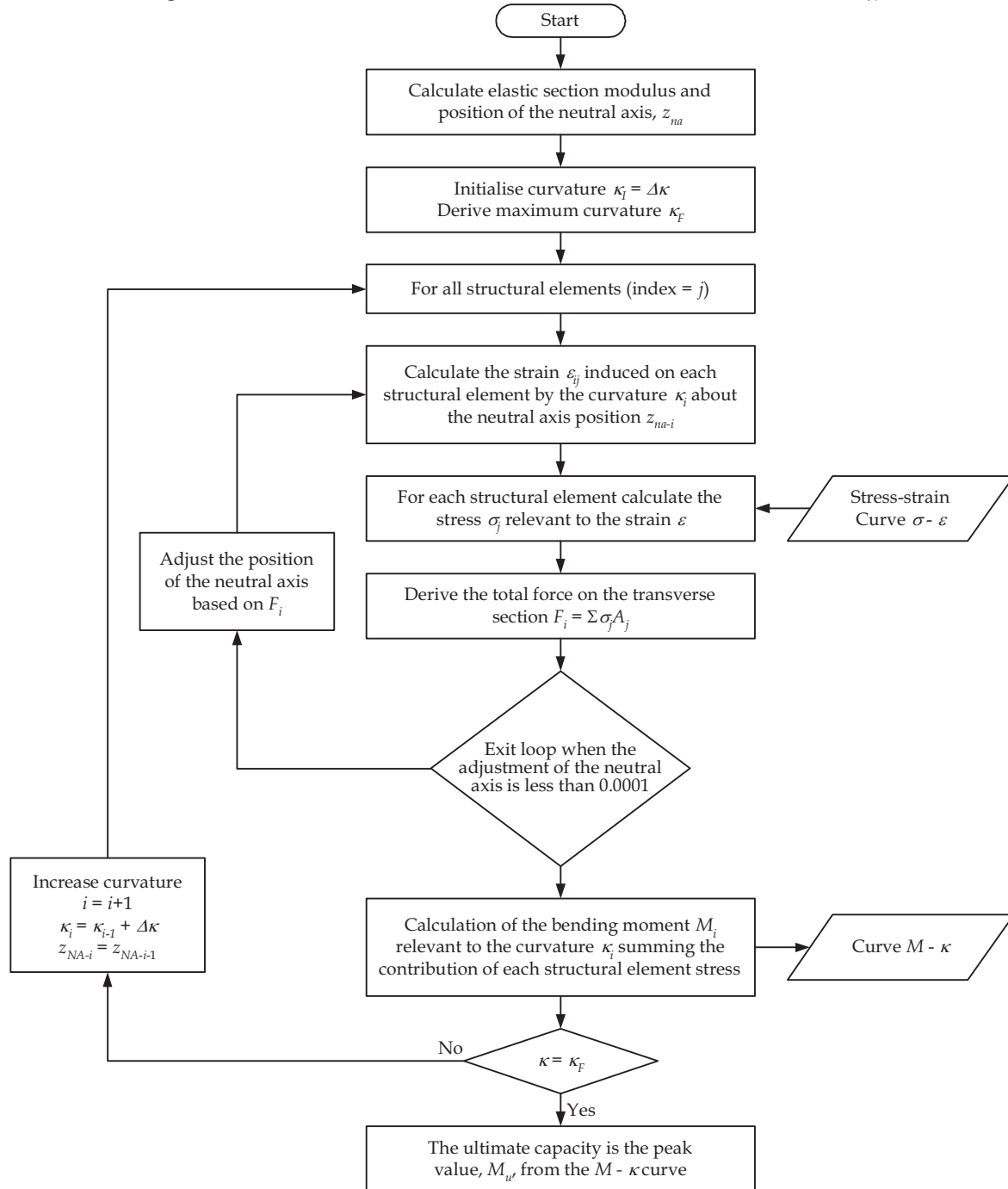

2.2.2 Assumptions and modelling of the hull girder cross-section

2.2.2.1 In applying the procedure described in 2.2.1, the following assumptions are to be made:

- (a) The ultimate strength is calculated at a hull girder transverse section between two adjacent transverse webs.
- (b) The hull girder transverse section remains plane during each curvature increment.
- (c) The material properties of steel are assumed to be elastic, perfectly plastic.
- (d) The hull girder transverse section can be divided into a set of elements which act independently of each other.

2.2.2.2 The elements making up the hull girder transverse section are:

- (a) longitudinal stiffeners with attached plating, the structural behaviour is given in 2.3.1
- (b) transversely stiffened plate panels, the structural behaviour is given in 2.3.1
- (c) hard corners, as defined in 2.2.2.3, the structural behaviour is given in 2.3.2

2.2.2.3 The following structural areas are to be defined as hard corners:

- (a) the plating area adjacent to intersecting plates
- (b) the plating area adjacent to knuckles in the plating with an angle greater than 30 degrees.
- (c) plating comprising rounded gunwales

An illustration of hard corner definition for girders on longitudinal bulkheads is given in **Fig. A.2.3**. The hard corner size is defined in **2.2.2.4**.

2.2.2.4 The size and modelling of hard corner elements is to be as follows:

- (a) it is to be assumed that the hard corner extends up to $s/2$ from the plate intersection for longitudinally stiffened plate, where s is the stiffener spacing
- (b) it is to be assumed that the hard corner extends up to $20t_{grs}$ from the plate intersection for transversely stiffened plates, where t_{grs} is the gross plate thickness.

Note :

- (a) For transversely stiffened plate, the effective breadth of plate for the load shortening portion of the stress-strain curve is to be taken as the full plate breadth, i.e. to the intersection of other plates – not from the end of the hard corner if any. The area on which the value of σ_{CR5} defined in **2.3.8.1** applies is to be taken as the breadth between the hard corners, i.e. excluding the end of the hard corner if any.
- (b) For longitudinally stiffened plate, the effective breadth of attached plate is equal to the mean spacing of the ordinary stiffener when the panels on both sides of the stiffener are longitudinally stiffened, or equal to the breadth of the longitudinally stiffened panel when the panel on one side of the stiffener is longitudinally stiffened and the other panel is of the transversely stiffened.

Fig. A.2.3 Example of Defining Structural Elements

a) Example showing side shell, inner hull and deck

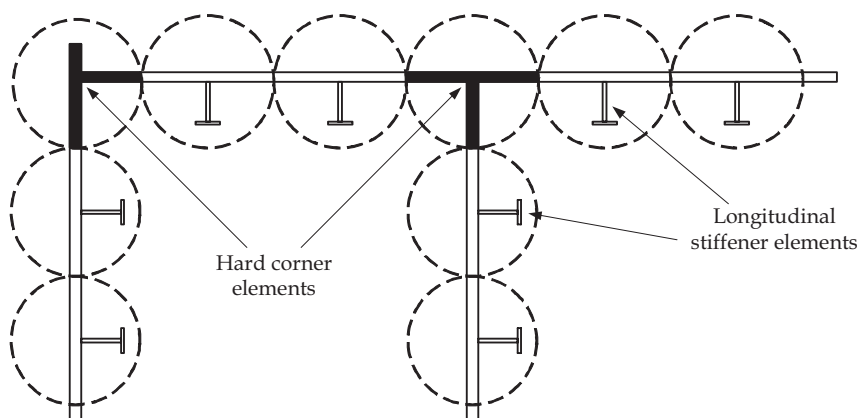

b) Example showing girder on longitudinal bulkhead

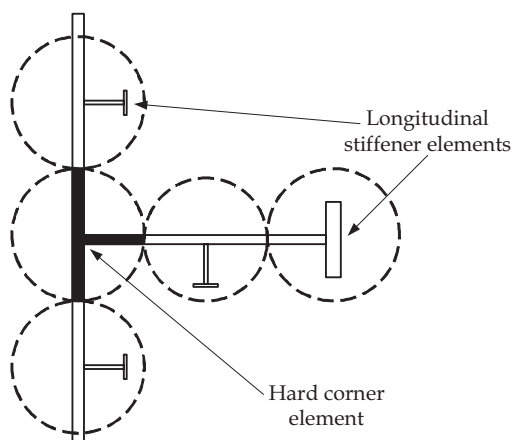

2.2.2.5 Where the plate members are stiffened by non-continuous longitudinal stiffeners, the non-continuous stiffeners are considered only as dividing a plate into various elementary plate panels.

2.2.2.6 Openings are to be considered in accordance with **Section 4/2.6.3**.

2.2.2.7 Where attached plating is made of steels having different thicknesses and/or yield stresses, an average thickness and/or average yield stress obtained by the following formula are to be used for the calculation:

$$(a) \quad t = \frac{t_1 s_1 + t_2 s_2}{s}$$

$$(b) \quad \sigma_{ydp} = \frac{\sigma_{ydp1} t_1 s_1 + \sigma_{ydp2} t_2 s_2}{ts}$$

Where:

$t_1, s_1, t_2, s_2, \sigma_{ydp1}, \sigma_{ydp2}, s$, see **Fig.A.2.4**.

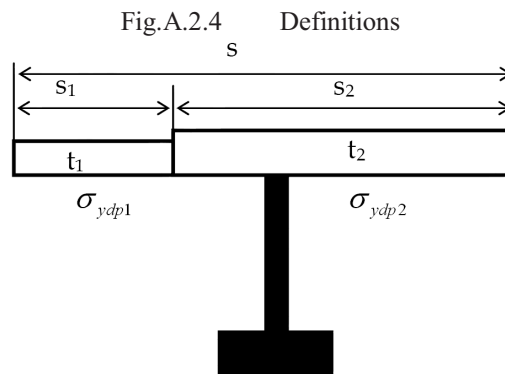

2.3 Stress-strain Curves σ - ϵ (or Load-end Shortening Curves)

2.3.1 Plate panels and stiffeners

2.3.1.1 Plate panels and stiffeners are assumed to fail according to one of the modes of failure specified in **Table A.2.1**. The relevant stress-strain curve σ - ϵ is to be obtained for lengthening and shortening strains according to **Table A.2.1**.

2.3.1.2 Where the plate members are stiffened by non-continuous longitudinal stiffeners, the stress of the element is to be obtained in accordance with **2.3.3** to **2.3.7**, taking into account the non-continuous longitudinal stiffener. In calculating the total forces for checking the hull girder ultimate strength, the area of non-continuous longitudinal stiffener is to be assumed as zero.

2.3.1.3 Where openings are provided in the plate panel, the considered area of the element is to be obtained by deducting the opening area from the plating in calculating the total force for checking the hull girder ultimate strength. Openings are to be considered in accordance with **Section 4/2.6.3**.

2.3.2 Hard corners

2.3.2.1 Hard corners are sturdier elements which are assumed to buckle and fail in an elastic, perfectly plastic manner. The relevant stress strain curve σ - ϵ is to be obtained for lengthened and shortened hard corners according to **2.3.3**.

Table A.2.1 Modes of Failure of Plate Panels and Stiffeners

Element	Mode of failure	Stress-strain curve σ - ε defined in
Lengthened transversely framed plate panels or stiffeners	Elastic, perfectly plastic failure	See 2.3.3
Shortened stiffeners	Beam column buckling	See 2.3.4
	Torsional buckling	See 2.3.5
	Web local buckling of flanged profiles	See 2.3.6
	Web local buckling of flat bars	See 2.3.7
Shortened transversely framed plate panels	Plate buckling	See 2.3.8

2.3.3 Elasto-plastic failure of structural elements

2.3.3.1 The equation describing the stress-strain curve σ - ε or the elasto-plastic failure of structural elements is to be obtained from the following formula, valid for both positive (compression or shortening) of hard corners and negative (tension or lengthening) strains of all elements (see **Fig. A.2.5**):

$$\sigma = \Phi \sigma_{ydA}$$

Where:

Φ : edge function

$$\Phi = -1 \quad \text{for} \quad \varepsilon < -1$$

$$\Phi = \varepsilon \quad \text{for} \quad -1 < \varepsilon < 1$$

$$\Phi = 1 \quad \text{for} \quad \varepsilon > 1$$

ε : relative strain

$$\varepsilon = \frac{\varepsilon_E}{\varepsilon_{yd}}$$

ε_E : element strain

ε_{yd} : strain corresponding to yield stress in the element

$$\varepsilon_{yd} = \frac{\sigma_{ydA}}{E}$$

σ_{ydA} : equivalent minimum yield stress of the considered element, in N/mm^2

$$\sigma_{ydA} = \frac{\sigma_{ydp} A_{p-net50} + \sigma_{yds} A_{s-net50}}{A_{p-net50} + A_{s-net50}}$$

σ_{ydp} : specified minimum yield stress of the material of the plate, in N/mm^2

σ_{yds} : specified minimum yield stress of the material of the stiffener, in N/mm^2

$A_{p-net50}$: net sectional area of attached plating, in cm^2

$A_{s-net50}$: net sectional area of stiffener without attached plating, in cm^2

Note :

The signs of the stresses and strains in this Appendix are opposite to those in the rest of this Part

Fig. A.2.5 Example of Stress Strain Curves σ - ε

a) Stress strain curve σ - ε for elastic, perfectly plastic failure of a hard corner

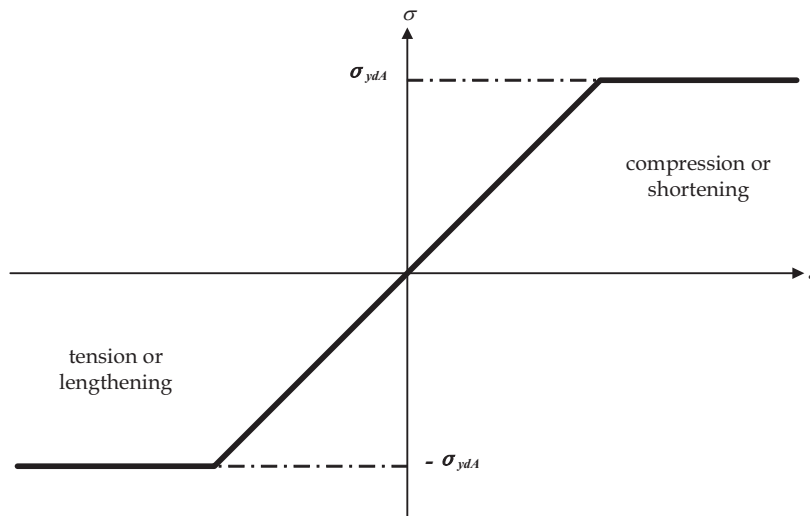

b) Typical stress strain curve σ - ε for elasto-plastic failure of a stiffener

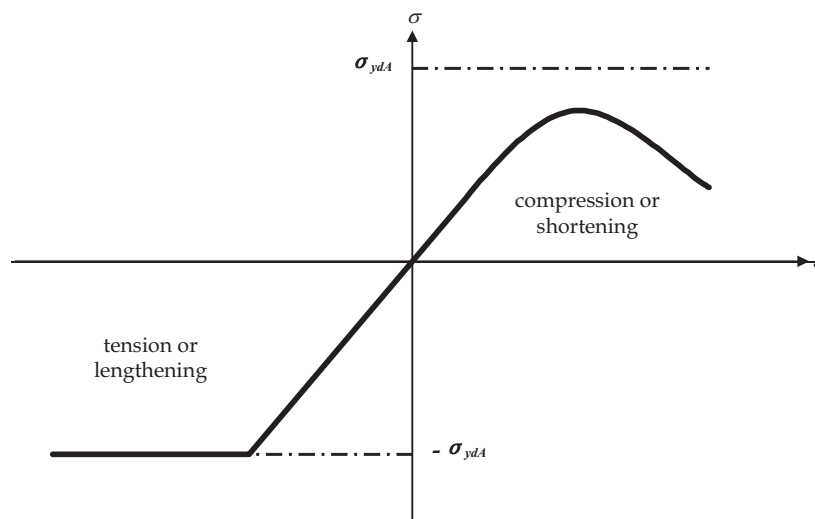

2.3.4 Beam column buckling

2.3.4.1 The equation describing the shortening portion of the stress strain curve σ_{CR1} - ε for the beam column buckling of stiffeners is to be obtained from the following formula:

$$\sigma_{CR1} = \Phi \sigma_{C1} \left(\frac{A_{s-net50} + 10^{-2} b_{eff-p} t_{net50}}{A_{s-net50} + 10^{-2} s t_{net50}} \right) \quad (N/mm^2)$$

Where:

Φ : edge function defined in 2.3.3.1

$A_{s-net50}$: net area of the stiffener, in cm^2 , without attached plating

σ_{C1} : critical stress, in N/mm^2

$$\sigma_{C1} = \frac{\sigma_{E1}}{\varepsilon} \quad \text{for } \sigma_{E1} \leq \frac{\sigma_{ydB}}{2} \varepsilon$$

$$\sigma_{C1} = \sigma_{ydB} \left(1 - \frac{\sigma_{ydB} \varepsilon}{4 \sigma_{E1}} \right) \quad \text{for } \sigma_{E1} > \frac{\sigma_{ydB}}{2} \varepsilon$$

ε : relative strain defined in 2.3.3.1

σ_{E1} : Euler column buckling stress, in N/mm^2

$$\sigma_{E1} = \pi^2 E \frac{I_{E-net50}}{A_{E-net50} l_{stf}^2} 10^{-4}$$

- E : modulus of elasticity, 2.06×10^5 (N/mm^2)
 $I_{E-net50}$: net moment of inertia of stiffeners, in cm^4 , with attached plating of width b_{eff-s}
 b_{eff-s} : effective width, in mm , of the attached plating for the stiffener

$$b_{eff-s} = \frac{s}{\beta_p} \quad \text{for } \beta_p > 1.0$$

$$b_{eff-s} = s \quad \text{for } \beta_p \leq 1.0$$

$$\beta_p = \frac{s}{t_{net50}} \sqrt{\frac{\varepsilon \sigma_{ydp}}{E}}$$

 s : plate breadth, in mm , taken as the spacing between the stiffeners, as defined in **Section 4/2.2.1**
 t_{net50} : net thickness of attached plating, in mm
 $A_{E-net50}$: net area, in cm^2 , of stiffeners with attached plating of width b_{eff-p}
 l_{stf} : span of stiffener, in m , equal to spacing between primary support members
 b_{eff-p} : effective width, in mm , of the plating

$$b_{eff-p} = \left(\frac{2.25}{\beta_p} - \frac{1.25}{\beta_p^2} \right) s \quad \text{for } \beta_p > 1.25$$

$$b_{eff-p} = s \quad \text{for } \beta_p \leq 1.25$$

 σ_{ydB} : equivalent minimum yield stress of the considered element, in N/mm^2

$$\sigma_{ydB} = \frac{\sigma_{ydp} A_{pE-net50} l_{pE} + \sigma_{yds} A_{s-net50} l_{sE}}{A_{pE-net50} l_{pE} + A_{s-net50} l_{sE}}$$

 $A_{pE-net50}$: effective area, in cm^2

$$A_{pE-net50} = 10^{-2} b_{eff-s} t_{net50}$$

 σ_{ydp} : specified minimum yield stress of the material of the plate, in N/mm^2
 σ_{yds} : specified minimum yield stress of the material of the stiffener, in N/mm^2
 l_{pE} : distance, in mm , measured from the neutral axis of the stiffener with attached plate of width, b_{eff-s} , to the bottom of the attached plate
 l_{sE} : distance, in mm , measured from the neutral axis of the stiffener with attached plate of width, b_{eff-s} , to the top of the stiffener

2.3.5 Torsional buckling of stiffeners

2.3.5.1 The equation describing the shortening portion of the stress-strain curve $\sigma_{CR2-\varepsilon}$ for the lateral-flexural buckling of stiffeners is to be obtained according to the following formula:

$$\sigma_{CR2} = \Phi \frac{A_{s-net50} \sigma_{C2} + 10^{-2} s t_{net50} \sigma_{CP}}{A_{s-net50} + 10^{-2} s t_{net50}} \quad (N/mm^2)$$

Where:

- Φ : edge function defined in **2.3.3.1**
 $A_{s-net50}$: net area of the stiffener, in cm^2 , without attached plating
 σ_{C2} : critical stress, in: N/mm^2

$$\sigma_{C2} = \frac{\sigma_{E2}}{\varepsilon} \quad \text{for } \sigma_{E2} \leq \frac{\sigma_{yds}}{2} \varepsilon$$

$$\sigma_{C2} = \sigma_{yds} \left(1 - \frac{\sigma_{yds} \varepsilon}{4 \sigma_{E2}} \right) \quad \text{for } \sigma_{E2} > \frac{\sigma_{yds}}{2} \varepsilon$$

 σ_{E2} : Euler torsional buckling stress, in N/mm^2

$$\sigma_{E2} = \sigma_{ET}$$

 σ_{ET} : reference stress for torsional buckling, in N/mm^2 , defined in **Section 10/3.3.3.1**, calculated based on gross thickness minus the corrosion addition $0.5 t_{corr}$.
 ε : relative strain defined in **2.3.3.1**
 s : plate breadth, in mm , taken as the spacing between the stiffeners, as

defined in **Section 4/2.2.1**

- t_{net50} : net thickness of attached plating, in mm
 σ_{CP} : ultimate strength of the attached plating for the stiffener, in N/mm^2
 $\sigma_{CP} = \left(\frac{2.25}{\beta_p} - \frac{1.25}{\beta_p^2} \right) \sigma_{ydp}$ for $\beta_p > 1.25$
 $\sigma_{CP} = \sigma_{ydp}$ for $\beta_p \leq 1.25$
 β_p : coefficient defined in **2.3.4**
 σ_{ydp} : specified minimum yield stress of the material of the plate, in N/mm^2
 σ_{yds} : specified minimum yield stress of the material of the stiffener, in N/mm^2

2.3.6 Web local buckling of stiffeners with flanged profiles

2.3.6.1 The equation describing the shortening portion of the stress strain curve $\sigma_{CR3-\varepsilon}$ for the web local buckling of flanged stiffeners is to be obtained from the following formula:

$$\sigma_{CR3} = \Phi \frac{b_{eff-p} t_{net50} \sigma_{ydp} + (d_{w-eff} t_{w-net50} + b_f t_{f-net50}) \sigma_{yds}}{s t_{net50} + d_w t_{w-net50} + b_f t_{f-net50}} \quad (N/mm^2)$$

Where:

- Φ : edge function defined in **2.3.3.1**
 b_{eff-p} : effective width, in mm , of the plating, defined in **2.3.4**
 t_{net50} : net thickness of plate, in mm
 d_w : depth of the web, in mm
 $t_{w-net50}$: net thickness of web, in mm
 b_f : breadth of the flange, in mm
 $t_{f-net50}$: net thickness of flange, in mm
 s : plate breadth, in mm , taken as the spacing between the stiffeners, as defined in **Section 4/2.2.1**
 d_{w-eff} : effective depth of the web, in mm
 $d_{w-eff} = \left(\frac{2.25}{\beta_w} - \frac{1.25}{\beta_w^2} \right) d_w$ for $\beta_w > 1.25$
 $d_{w-eff} = d_w$ for $\beta_w \leq 1.25$
 $\beta_w = \frac{d_w}{t_{w-net50}} \sqrt{\frac{\varepsilon \sigma_{yds}}{E}}$
 ε : relative strain defined in **2.3.3.1**
 E : modulus of elasticity, $2.06 \times 10^5 N/mm^2$
 σ_{ydp} : specified minimum yield stress of the material of the plate, in N/mm^2
 σ_{yds} : specified minimum yield stress of the material of the stiffener, in N/mm^2

2.3.7 Web local buckling of flat bar stiffeners

2.3.7.1 The equation describing the shortening portion of the stress-strain curve $\sigma_{CR4-\varepsilon}$ for the web local buckling of flat bar stiffeners is to be obtained from the following formula:

$$\sigma_{CR4} = \Phi \left(\frac{s t_{net50} \sigma_{CP} + 10^{-2} A_{s-net50} \sigma_{C4}}{s t_{net50} + 10^{-2} A_{s-net50}} \right)$$

Where:

- Φ : edge function defined in **2.3.3.1**
 σ_{CP} : ultimate strength of the attached plating, in N/mm^2 , defined in **2.3.5**
 σ_{C4} : critical stress, in N/mm^2
 $\sigma_{C4} = \frac{\sigma_{E4}}{\varepsilon}$ for $\sigma_{E4} \leq \frac{\sigma_{yds}}{2} \varepsilon$
 $\sigma_{C4} = \sigma_{yds} \left(1 - \frac{\sigma_{yds} \varepsilon}{4 \sigma_{E4}} \right)$ for $\sigma_{E4} > \frac{\sigma_{yds}}{2} \varepsilon$
 σ_{E4} : Euler buckling stress, in N/mm^2

$$\sigma_{E4} = 160000 \left(\frac{t_{w-net50}}{d_w} \right)^2$$

- ε : relative strain defined in **2.3.3.1**.
 $A_{s-net50}$: net area of stiffener, in cm^2 , see **2.3.5.1**
 $t_{w-net50}$: net thickness of web, in mm
 d_w : depth of the web, in mm
 s : plate breadth, in mm , taken as the spacing between the stiffeners, as defined in **Section 4/2.2.1**
 t_{net50} : net thickness of attached plating, in mm
 σ_{yds} : specified minimum yield stress of the material of the stiffener, in N/mm^2

2.3.8 Buckling of transversely stiffened plate panels

2.3.8.1 The equation describing the shortening portion of the stress-strain curve $\sigma_{CR5-\varepsilon}$ for the buckling of transversely stiffened panels is to be obtained from the following formula:

$$\sigma_{CR5} = \min \left\{ \begin{array}{l} \Phi \sigma_{ydp} \left[\frac{s}{1000l_{stf}} \left(\frac{2.25}{\beta_p} - \frac{1.25}{\beta_p^2} \right) + 0.1 \left(1 - \frac{s}{1000l_{stf}} \right) \left(1 + \frac{1}{\beta_p^2} \right)^2 \right] \\ \sigma_{ydp} \Phi \end{array} \right. \quad (N/mm^2)$$

Where:

- β_p : coefficient defined in **2.3.4.1**
 Φ : edge function defined in **2.3.3.1**
 s : plate breadth, in mm , taken as the spacing between the stiffeners, as defined in **Section 4/2.2.1**
 l_{stf} : stiffener span, in m , equal to spacing between primary support members
 σ_{ydp} : specified minimum yield stress of the material of the plate, in N/mm^2

3. Alternative Methods

3.1 General

3.1.1 Considerations for alternative models

3.1.1.1 The bending moment-curvature relationship, $M-\kappa$, may be established by alternative methods. Such models are to consider all the relevant effects important to the non-linear response with due considerations of:

- (a) non-linear geometrical behaviour
- (b) inelastic material behaviour
- (c) geometrical imperfections and residual stresses (geometrical out-of flatness of plate and stiffeners)
- (d) simultaneously acting loads:
 - bi-axial compression
 - bi-axial tension
 - shear and lateral pressure
- (e) boundary conditions
- (f) interactions between buckling modes
- (g) interactions between structural elements such as plates, stiffeners, girders etc.
- (h) post-buckling capacity.

3.2 Methods

3.2.1 Incremental-iterative procedure

3.2.1.1 The most generally used method to assess the hull girder ultimate moment capacity is to derive the non-linear moment-curvature relationship, $M-\kappa$, by incrementally increasing the bending curvature, κ , of the hull section between two adjacent transverse frames and then identifying the maximum moment along this curve as the ultimate bending capacity, M_U .

3.2.1.2 The $M-\kappa$ curve is to be based on the axial non-linear $P-\varepsilon$ (load/strain) load-shortening curves for individual structural component in the cross-section. The $P-\varepsilon$ curves shall consider all relevant structural effects as listed in 3.1.1.1.

3.2.2 Non-linear finite element analysis

3.2.2.1 Advanced non-linear finite element analyses models may be used for the assessment of the hull girder ultimate capacity. Such models are to consider the relevant effects important to the non-linear responses with due consideration of the items listed in 3.1.1.1.

3.2.2.2 Particular attention is to be given to modelling the shape and size of geometrical imperfections. It is to be ensured that the shape and size of geometrical imperfections trigger the most critical failure modes.

Appendix B STRUCTURAL STRENGTH ASSESSMENT

1. General

1.1 Application

1.1.1 General

1.1.1.1 In accordance with **Section 9/2.1**, a finite element (FE) assessment is to be carried out to verify the strength of the hull structure.

1.1.1.2 The structural assessment is to be carried out in accordance with the requirements given in this Appendix. The structural assessment is to verify that the acceptance criteria specified are complied with.

1.1.1.3 The requirements in this Appendix apply to the assessment of longitudinal hull girder structural members, primary supporting structural members and transverse bulkheads of the tanks in the midship cargo region and, in addition, the assessment of strengthening of longitudinal hull girder shear structural members, as defined in **Section 9/2.2.1.1** and **Section 4/Table 4.1.1**, in way of transverse bulkheads for hull girder vertical shear loads in the forward and aft cargo regions. The strength assessment of longitudinal hull girder shear structural members given in this Appendix is not applicable for forward transverse collision bulkhead, engine room transverse bulkhead and slop tank transverse bulkheads.

1.1.1.4 For the purpose of the FE structural assessment the cargo tank regions are as defined in **Fig. B.1.1**.

1.1.1.5 Cargo tank structural strength analysis, in accordance with **Appendix B/2**, for the assessment of scantlings of longitudinal hull girder structural members, primary supporting structural members and transverse bulkheads in tanks within the midship cargo region, is mandatory. The assessment is to be based on the maximum permissible still water (load combination S) and combined permissible still water and wave hull girder vertical shear forces (load combination S+D) between and including the forward bulkhead of the aft most cargo tank and $0.65L_{CSR-T}$ from AP, but not including the engine room and slop tank transverse bulkheads, *see Fig. B.1.1(a)*.

1.1.1.6 The assessment of longitudinal hull girder shear structural members in the forward cargo region, in accordance with **Appendix B/2**, is mandatory. The strengthening of these structural members in way of transverse bulkheads in the tanks of the forward cargo region may be based on the maximum permissible still water (load combination S) and combined permissible still water and wave hull girder vertical shear forces (load combination S+D) at the bulkhead positions forward of $0.65L_{CSR-T}$ from AP, but not including the forward collision bulkhead, *see Fig. B.1.1(b)*.

1.1.1.7 Strengthening of longitudinal hull girder shear structural members in way of transverse bulkheads of the tanks in the midship cargo region and the aft cargo region, in accordance with **Appendix B/2**, may be based on the scantling result obtained from the midship cargo tank analysis as described in **1.1.1.5**.

1.1.1.8 Alternatively, optional assessment may be carried out to determine the strengthening requirement of longitudinal hull girder shear structural members in way of individual transverse bulkheads based on the permissible still water (load combination S) and combined permissible still water and wave hull girder vertical shear forces (load combination S+D) at the transverse bulkhead position under consideration, *see Fig. B.1.1(b)*.

1.1.1.9 Fine mesh finite element analysis, in accordance with **Appendix B/3**, and the finite element based fatigue assessment of lower hopper knuckle joint, in accordance with **Appendix B/4**, are mandatory for the midship cargo region.

Fig. B.1.1 Definition of Cargo Tank Regions for FE Structural Assessment

(a) Midship cargo tank strength assessment

Transverse bulkheads to be considered for selection of hull girder shear forces (midship cargo tank strength assessment)

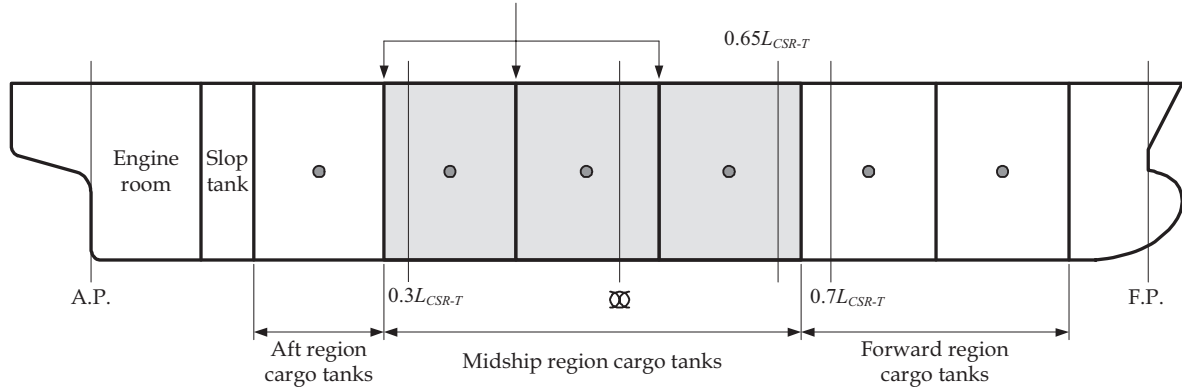

(b) Assessment of longitudinal hull girder shear structural members

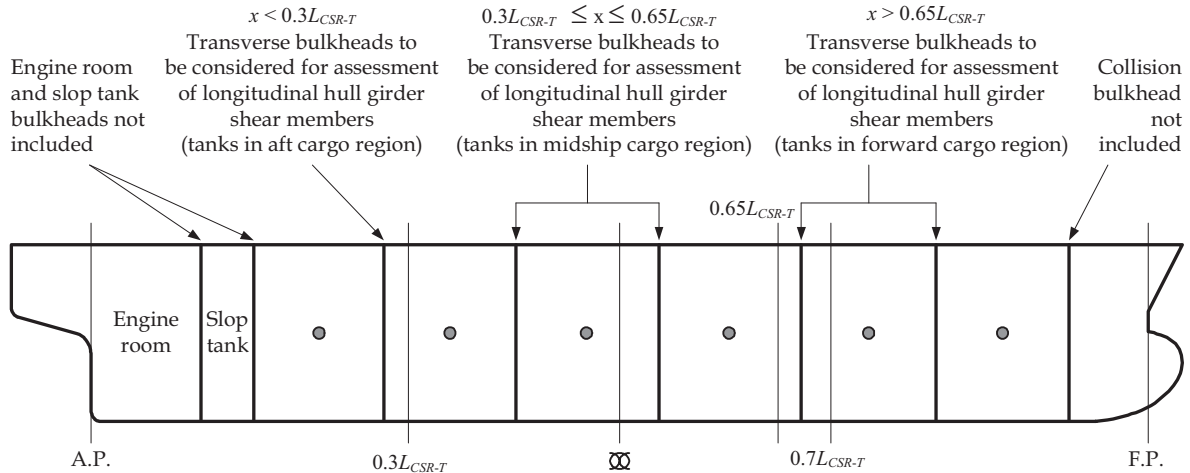

Note:

1. Tanks in the forward cargo region are defined as tanks with their longitudinal centre of gravity position forward of $0.7L_{CSR-T}$ from AP.
2. Tanks in the midship cargo region are defined as tanks with their longitudinal centre of gravity position at or forward of $0.3L_{CSR-T}$ from AP and at or aft of $0.7L_{CSR-T}$ from AP.
3. Tanks in the aft cargo region are defined as tanks with their longitudinal centre of gravity position aft of $0.3L_{CSR-T}$ from AP.

1.2 Symbols, Units and Definitions

1.2.1 General

1.2.1.1 The symbols and definitions, applicable to this section, are given in **Section 4/1**, **Section 7** and as follows:

- a_v : vertical acceleration, taken at centre of gravity of tank
- a_t : transverse acceleration, taken at centre of gravity of tank
- a_{lng} : longitudinal acceleration, taken at centre of gravity of tank
- E : Modulus of Elasticity of steel, $2.06 \times 10^5 \text{ N/mm}^2$
- M_{wv} : vertical wave bending moment for a dynamic load case
- M_{sw} : vertical still water bending moment for a finite element loading pattern
- M_h : horizontal wave bending moment for a dynamic load case
- Q_{wv} : vertical wave shear force for a dynamic load case
- Q_{sw} : vertical still water shear force for a finite element loading pattern
- T_{LC} : draught at the loading condition being considered

T_{sc}	: scantling draught, as defined in Section 4/1.1.5.5
T_{bal-em}	: emergency draught of ship
t_{grs}	: proposed new building gross thickness excluding Owner's extras, see Section 2/4.3.4
t_{corr}	: corrosion addition, as defined in Section 6/3.2
σ_{yd}	: specified minimum yield stress of the material, N/mm^2
σ_{vm}	: von Mises stress $= \sqrt{\sigma_x^2 + \sigma_y^2 - \sigma_x \sigma_y + 3\tau_{xy}^2}$
σ_x	: axial stress in element x direction
σ_y	: axial stress in element y direction
τ_{xy}	: element shear stress in x-y plane
δ_x	: displacement in x direction, in accordance with the coordinate system defined in Section 4/1.4
δ_y	: displacement in y direction, in accordance with the coordinate system defined in Section 4/1.4
δ_z	: displacement in z direction, in accordance with the coordinate system defined in Section 4/1.4
θ_x	: rotation about x axis, in accordance with the coordinate system defined in Section 4/1.4
θ_y	: rotation about y axis, in accordance with the coordinate system defined in Section 4/1.4
θ_z	: rotation about z axis, in accordance with the coordinate system defined in Section 4/1.4

1.2.1.2 The nomenclature of structural components is defined in **Section 4/1.5**.

1.2.1.3 Consistent co-ordinate and unit systems are to be used throughout all parts of the structural analysis. However, in calculations using Rule Formulae, the units and co-ordinate system as specified are to be used. Where output values from Rule formulae are in a different unit and/or co-ordinate system as used in the structural analysis, the output values are to be converted to the appropriate unit and co-ordinate system.

1.2.2 Finite element types

1.2.2.1 The structural assessment is to be based on linear finite element analysis of three dimensional structural models. The general types of finite elements to be used in the finite element analysis are given in **Table B.1.1**.

1.2.2.2 Two node line elements and three or four node plate/shell elements are considered sufficient for the representation of the hull structure. The mesh requirements given in this Appendix are based on the assumption that these elements are used in the finite element models. However, higher order elements may also be used.

Table B.1.1 Types of Finite Element

Rod (or truss) element	Line element with axial stiffness only and constant cross-sectional area along the length of the element
Beam element	Line element with axial, torsional and bi-directional shear and bending stiffness and with constant properties along the length of the element
Membrane (or plane-stress) plate element	Plate element with bi-axial and in-plane plate element stiffness with constant thickness
Shell (or bending plate) element	Plate element with in-plane stiffness and out-of-plane bending stiffness with constant thickness

1.2.2.3 For the cargo tank and fine mesh strength analyses as specified in **Appendix B/2** and **B/3**, the assessment against stress acceptance criteria is to be based on membrane (or in-plane) stresses of plate elements. For the fatigue assessment as specified in **Appendix B/4**, the calculation of dynamic stress range for the determination of fatigue life is to be based on surface stresses of plate elements.

2. Cargo Tank Structural Strength Analysis

2.1 Assessment

2.1.1 General

2.1.1.1 For tankers of conventional arrangements, the finite element strength assessment of the hull girder and primary supporting structural members is to be in accordance with the requirements in this section.

2.2 Structural Modelling

2.2.1 General

2.2.1.1 The longitudinal extent of the midship cargo tank finite element (FE) model is to cover three cargo tank lengths about midships. Where the tanks in the midship cargo region are of different lengths, the middle tank of the finite element model is to represent the cargo tank of the greatest length. The finite element model may be prismatic. The transverse bulkheads at the ends of the model are to be represented. Where corrugated transverse bulkheads are fitted, the model is to include the extent of the bulkhead stool structure forward and aft of the tanks at the model ends. The length of the model extending beyond the end transverse bulkheads is to be kept equal, at both ends. The web frames at the ends of the model are to be modelled. Typical finite element models representing the midship cargo tank region of different tanker configurations are shown in **Fig. B.2.1**.

2.2.1.2 The assessment of longitudinal hull girder shear structural members, as defined in **Section 9/2.2.1.1** and **Section 4/Table 4.1.1**, against hull girder vertical shear loads in the forward and aft cargo regions may be based on the midship cargo tank finite element model with modification of plate and stiffener properties where appropriate. Where a separate cargo tank finite element model is used for the assessment of shear strength, the model is to cover three tank lengths.

2.2.1.3 Both port and starboard sides of the ship are to be modelled. The full depth of the ship is to be modelled.

2.2.1.4 All main longitudinal and transverse structural elements are to be modelled. These include inner and outer shell, double bottom floor and girder system, transverse and vertical web frames, stringers and transverse and longitudinal bulkhead structures. All plates and stiffeners on the structure, including web stiffeners, are to be modelled, see **2.2.1.11**.

2.2.1.5 The reduced thickness used in the FE model of the cargo tanks, applicable to all plating and stiffener's web and flanges is to be calculated as follows:

$$t_{FEM-net50} = t_{grs} - 0.5t_{corr}$$

Where:

t_{grs} : gross thickness, as defined in **1.2**

t_{corr} : corrosion addition, as defined in **Section 6/3.2**

Fig. B.2.1 Typical 3-Tank FE Models Representing Midship Cargo Tank Region of Tankers

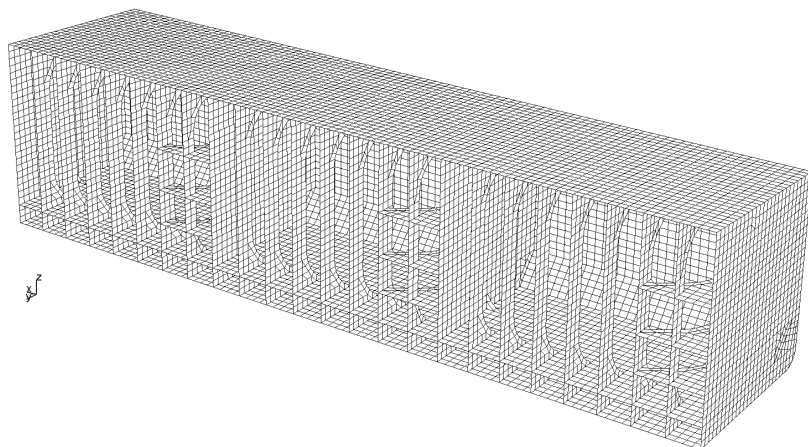

Typical Cargo Tank Model of an Aframax Oil Tanker (shows only starboard side of the full breadth model)

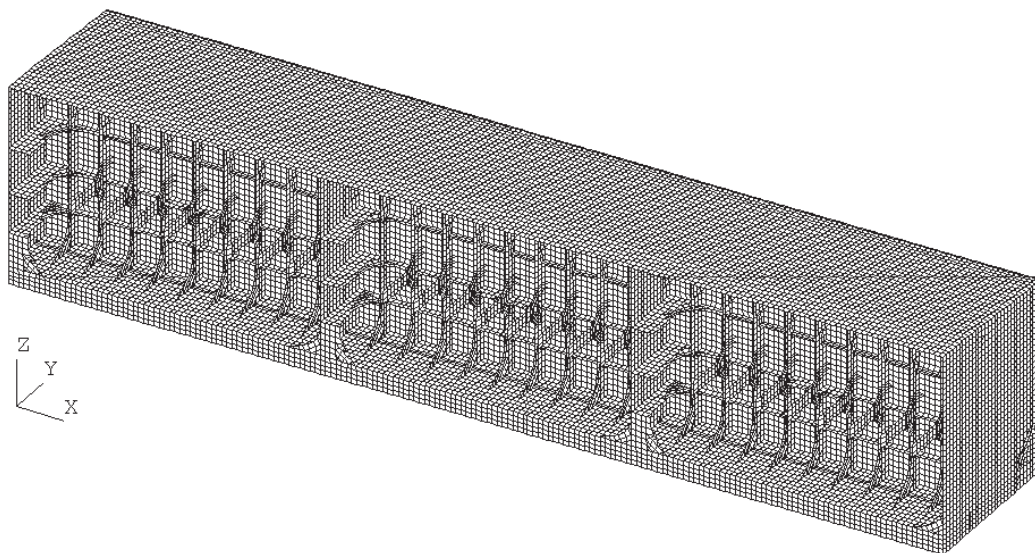

Typical Cargo Tank Model of a VLCC (shows only port side of the full breadth model)

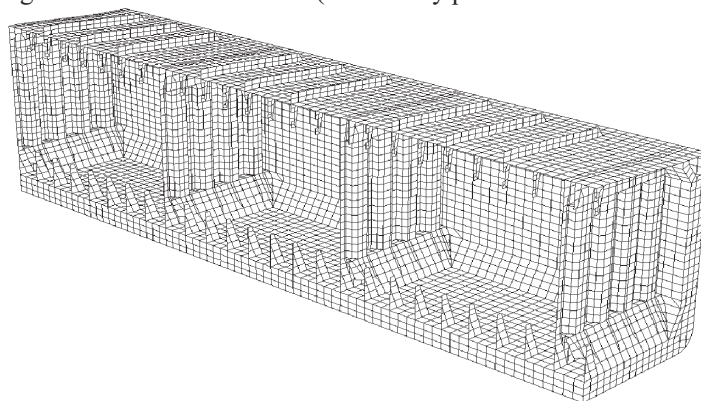

Typical Cargo Tank Model of a Product Tanker (shows only port side of the full breadth model)

2.2.1.6 The plate element mesh is to follow the stiffening system as far as practicable, hence representing the actual plate panels between stiffeners. In general, the plate element mesh is to satisfy the following requirements:

- one element between every longitudinal stiffener, see **Fig. B.2.2**. Longitudinally, the element length is not to be greater than 2 longitudinal spaces
- one element between every vertical stiffener on transverse bulkheads, see **Fig. B.2.3**
- one element between every web stiffener on transverse and vertical web frames, cross ties and stringers, see **Fig. B.2.2** and **Fig. B.2.4**
- at least three elements over the depth of double bottom girders and floors, transverse web frames, vertical web frames and horizontal stringers on transverse bulkheads. For cross ties, deck transverse and horizontal

stringers on transverse wash bulkheads and longitudinal bulkheads with a smaller web depth, representation using two elements over the depth is acceptable provided that there is at least one element between every web stiffener. The mesh size of adjacent structure is to be adjusted to suit

- (e) the mesh on the hopper tank web frame shall be fine enough to represent the shape of the web ring opening, see **Fig. B.2.2**
- (f) the curvature of the free edge on large brackets of primary support members is to be modelled accurately to avoid unrealistic high stress due to geometry discontinuities. In general, a mesh size equal to the stiffener spacing is acceptable. The bracket toe may be terminated at the nearest nodal point provided that the modelled length of the bracket arm does not exceed the actual bracket arm length. The bracket flange is not to be connected to the plating, see **Fig. B.2.5**. The modelling of the tapering part of the flange is to be in accordance with **2.2.1.14**. An acceptable mesh is shown in **Fig. B.2.5**. A finer mesh is to be used for the determination of detailed stress at the bracket toe, see **Appendix B/3**.

2.2.1.7 Corrugated bulkheads and bulkhead stools are to be modelled using shell plate elements, see **Fig. B.2.6**.

Diaphragms in the stools and internal longitudinal and vertical stiffeners on the stool plating are to be included in the model. Modelling is to be carried out as follows:

- (a) the shell element mesh on the flange and web of the corrugation is in general to follow the stiffener spacing inside the bulkhead stool
- (b) where difficulty occurs in matching the mesh on the corrugations directly with the mesh on the stool, it is acceptable to adjust the mesh on the stools in way of the corrugations in order that the corrugation bulkhead will retain its original geometrical shape. However, if the shape of the corrugation is adjusted in order to simplify the modelling procedure, this effect is to be taken into account in evaluation of stresses as described in **2.7.2.6**.
- (c) for a corrugated bulkhead without an upper stool and/or lower stool, it may be necessary to adjust the geometry in order to simplify the modelling. The adjustment is to be made such that the shape and position of the corrugations and primary support members are retained. Hence, the adjustment is to be made on stiffeners and plate seams if necessary.

2.2.1.8 The aspect ratio of the plate elements is in general not to exceed three. The use of triangular plate elements is to be kept to a minimum. Where possible, the aspect ratio of plate elements in areas where there are likely to be high stresses or a high stress gradient is to be kept close to one and the use of triangular elements is to be avoided.

2.2.1.9 Typical mesh arrangements of the cargo tank structure are shown in **Fig. B.2.7**.

2.2.1.10 Shell elements, in association with beam elements, are to be used to represent stiffened panels in areas under lateral pressure. Shell elements are to be used to represent unstiffened panels in areas under lateral pressure.

Membrane and rod elements may be used to represent non-tight structure under no pressure loads.

Fig. B.2.2 Typical Finite Element Mesh on Web Frame

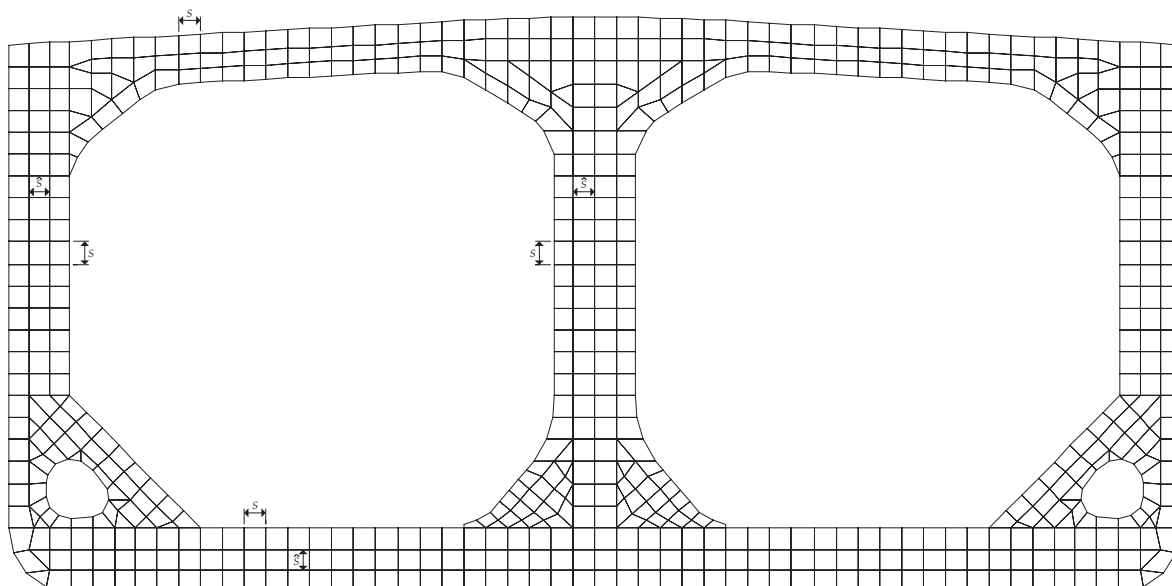

S = stiffener spacing

Fig. B.2.3 Typical Finite Element Mesh on Transverse Bulkhead

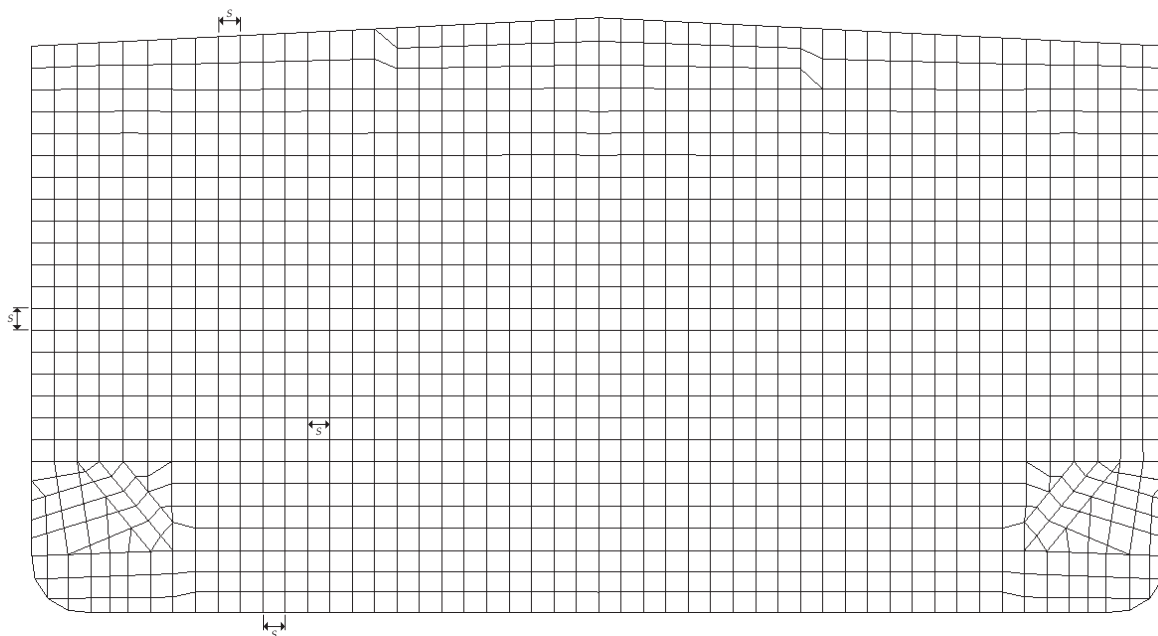

S = stiffener spacing

Fig. B.2.4 Typical Finite Element Mesh on Horizontal Transverse Stringer on Transverse Bulkhead

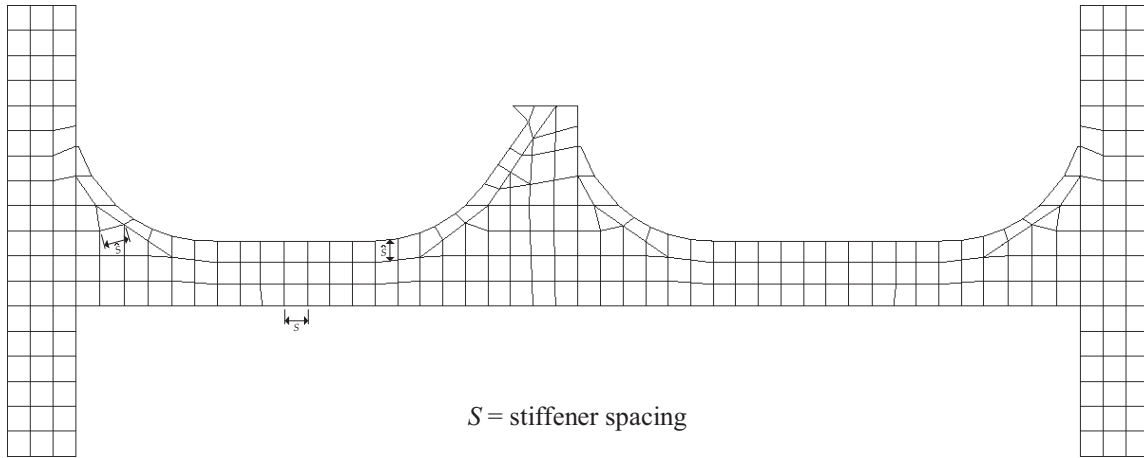

Fig. B.2.5 Typical Finite Element Mesh on Transverse Web Frame Main Bracket

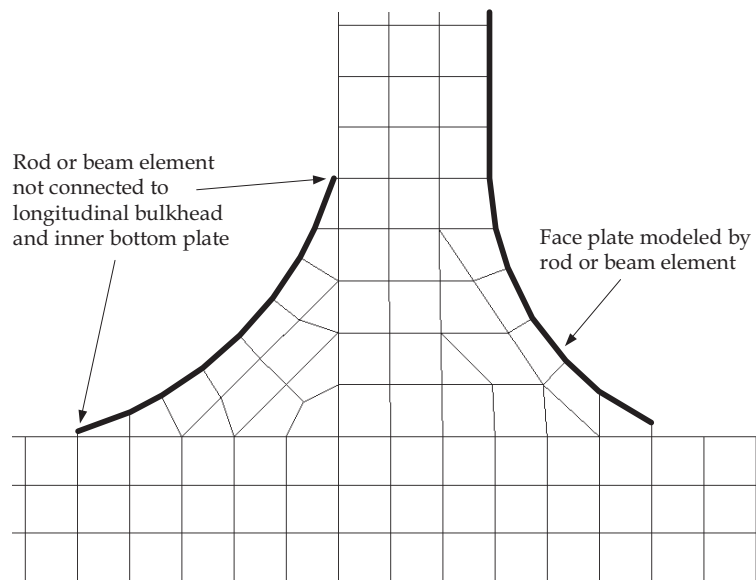

Fig. B.2.6 Typical Finite Element Mesh on Transverse Corrugated Bulkhead Structure

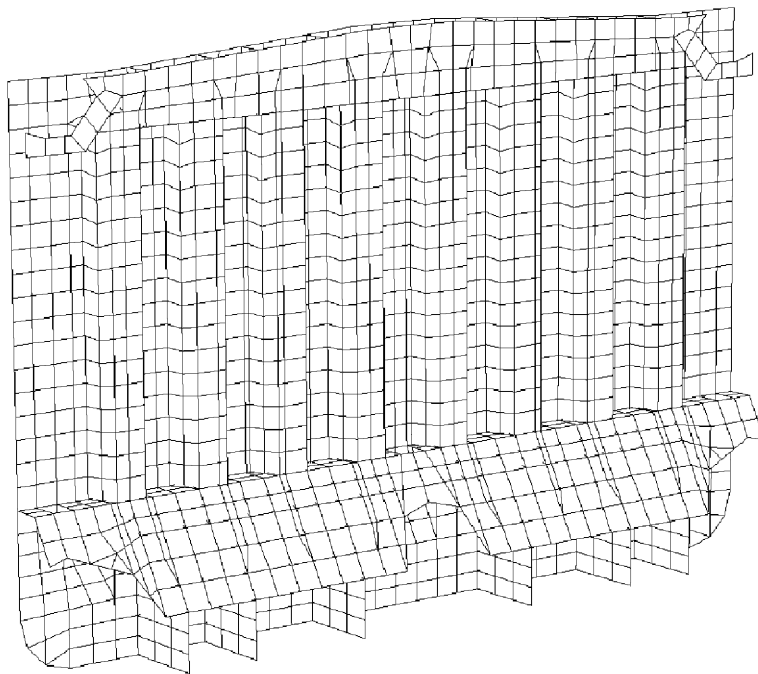
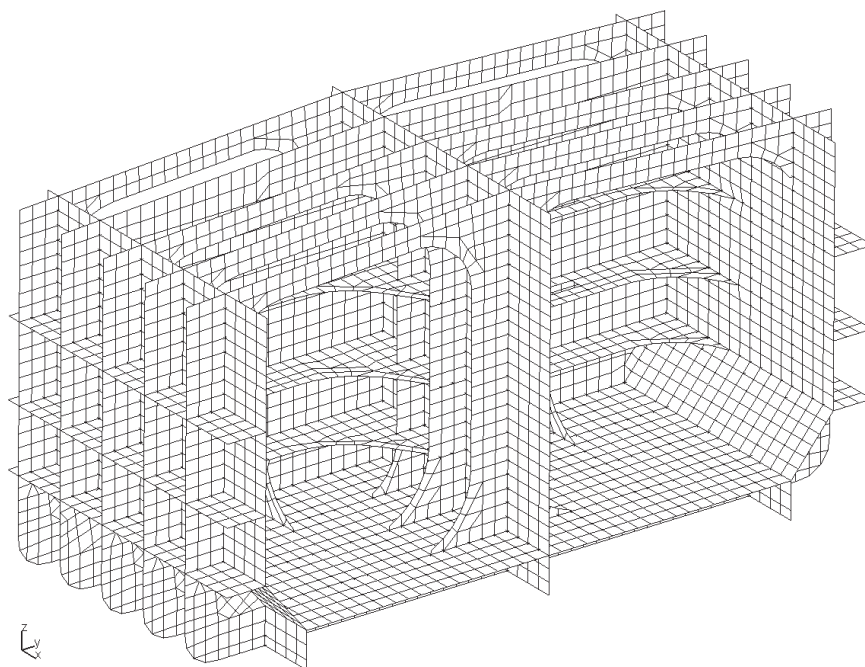
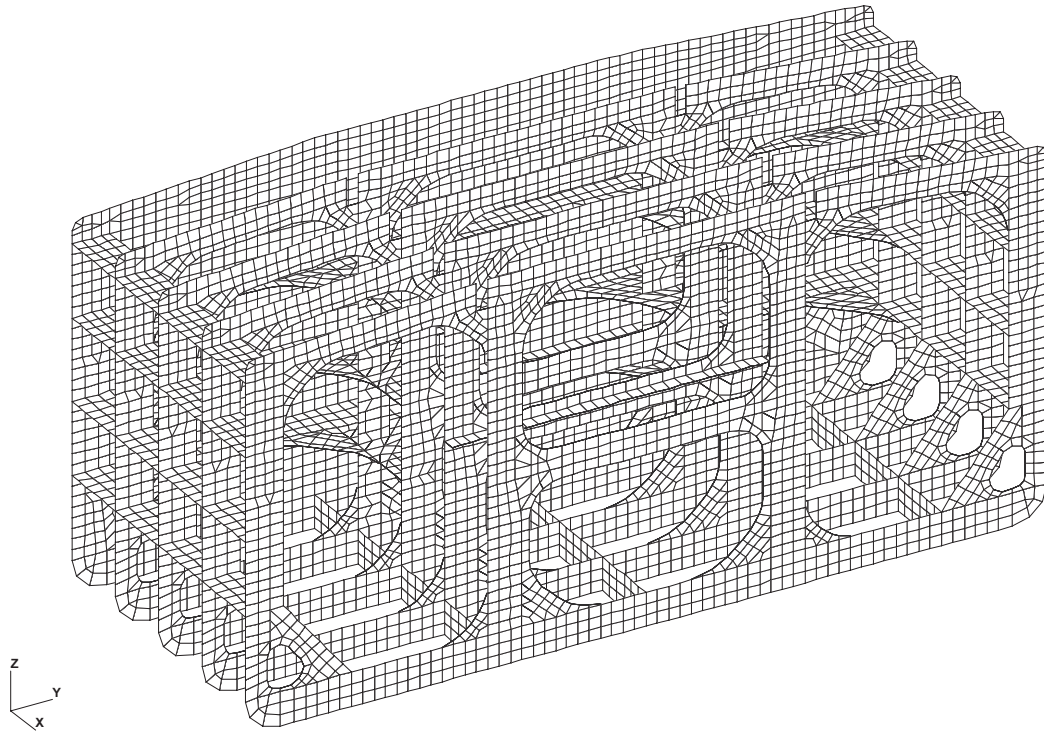

Fig. B.2.7 Typical Finite Element Mesh Arrangements of Cargo Tank Structure



Aframax Oil Tanker

Fig. B.2.7 (Continued) Typical Finite Element Mesh Arrangements of Cargo Tank Structure



VLCC

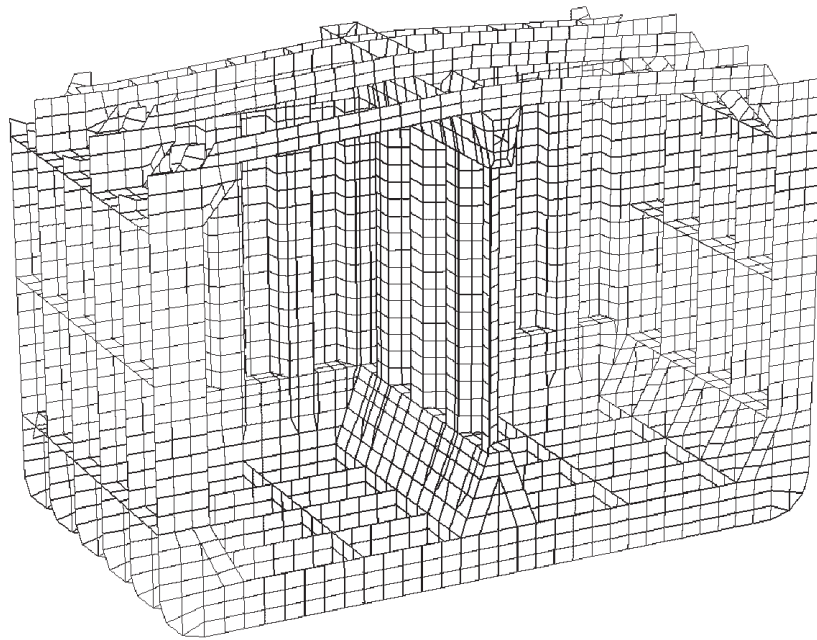

Product tanker

2.2.1.11 All local stiffeners are to be modelled. These stiffeners may be modelled using line elements positioned in the plane of the plating. Beam elements are to be used in areas under the action of lateral loads whilst rod (truss) elements may be used to represent local stiffeners on internal structural members under no lateral loads. The line elements are to have the following properties:

- (a) for beam elements, out of plane bending properties are to represent the inertia of the combined plating and stiffener. The width of the attached plate is to be taken as $\frac{1}{2} + \frac{1}{2}$ stiffener spacing on each side of the stiffener. The eccentricity of the neutral axis is not required to be modelled.
- (b) for beam and rod elements, other sectional properties are to be based on a cross sectional area representing the stiffener area, excluding the area of the attached plating.

2.2.1.12 The effective cross sectional area of non-continuous stiffeners is to be calculated in accordance with **Table B.2.1**.

Table B.2.1 Effective Cross Sectional Area of Stiffener Line Elements

Structure represented by line element	Effective area A_e	
Stiffener within a distance $2d_w$ from a sniped (non-continuous) end	All sections	$A_e = 25\% A_{n-net50}$
Stiffener outside a distance $2d_w$ from a sniped (non-continuous) end	All sections	$A_e = 100\% A_{n-net50}$

Where:

$A_{n-net50}$: average cross sectional area over length of line element

d_w : depth of stiffener web, excluding attached plate

2.2.1.13 Web stiffeners on primary support members are to be modelled. Where these stiffeners are not in line with the primary FE mesh, it is sufficient to place the line element along the nearby nodal points provided that the adjusted distance does not exceed 0.2 times the stiffener spacing under consideration. The stresses and buckling utilisation factors obtained need not be corrected for the adjustment. Buckling stiffeners on large brackets, deck transverses and stringers parallel to the flange are to be modelled. These stiffeners may be modelled using rod elements.

2.2.1.14 Face plates of primary support members and brackets may be modelled using rod elements. The effective cross sectional area at the curved part of the face plate is to be calculated in accordance with **Section 4/2.3.4**. The cross sectional area of a rod element representing the tapering part of the face plate is to be based on the average cross sectional area of the face plate in way of the element length.

2.2.1.15 Methods of representing openings in webs of primary support members are to be in accordance with **Table B.2.2**. Cut-outs for local stiffeners, scallops, drain and air holes need not be represented.

Table B.2.2 Representation of Openings in Primary Support Member Webs

$h_o/h < 0.35$	and	$g_o < 1.2$	Openings do not need to be modelled
$0.5 > h_o/h \geq 0.35$	and	$g_o < 1.2$	The plate modelled with mean thickness $t_{1-net50}$
$h_o/h < 0.5$	and	$2 > g_o \geq 1.2$	The plate modelled with mean thickness $t_{2-net50}$
$h_o/h \geq 0.5$	or	$g_o \geq 2.0$	The geometry of the opening is to be modelled

Where:

$$g_o = 1 + \frac{l_o^2}{2.6(h-h_o)^2}$$

$$t_{1-net50} = \frac{h-h_o}{h} t_{w-net50}$$

$$t_{2-net50} = \frac{h-h_o}{hg_o} t_{w-net50}$$

$t_{w-net50}$: net web thickness

l_o : length of opening parallel to primary support member web direction, see **Fig. B.2.8**

h_o : height of opening parallel to depth of web, see **Fig. B.2.8**

h : height of web of primary support member in way of opening, see **Fig. B.2.8**

t_{corr} : corrosion addition, as defined in **Section 6/3.2**

Notes:

1. For sequential openings where the distance, d_o , between openings is less than $0.25h$, the length l_o is to be taken as the length across openings as shown in **Fig. B.2.9**.
2. The same unit is to be used for l_o , h_o and h .

Fig. B.2.8 Openings in Web

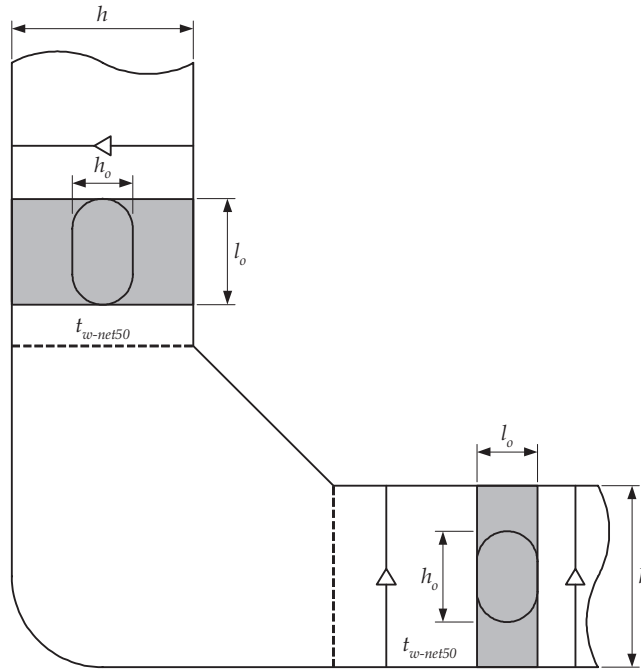
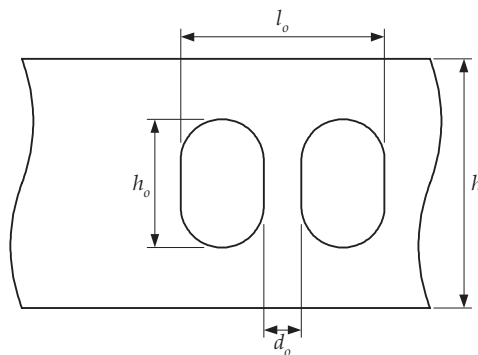

Fig. B.2.9 Length l_o for Sequential Openings with $d_o < h/4$



2.3 Loading Conditions

2.3.1 Finite element load cases

2.3.1.1 The standard design load combinations to be used in the structural analysis are given in **Tables B.2.3** and **B.2.4** for tankers with two oil-tight longitudinal bulkheads and one centreline oil-tight longitudinal bulkhead respectively.

2.3.1.2 For S+D design load combinations (seagoing load cases) the number of dynamic load cases required to be investigated for each loading pattern is indicated by the dynamic load case numbers specified for each loading pattern in **Tables B.2.3** and **B.2.4**. Each S+D design load combination consists of two parts:

- static loads, as described by the loading pattern, ship draught, hull girder still water bending moment and shear force specified, and
- dynamic loads defined in **Section 7/Table 7.6.2** for the dynamic load case number specified.

2.3.1.3 For tankers with two oil-tight longitudinal bulkheads and a cross tie arrangement in the centre cargo tanks, loading patterns A7 and A12 in **Table B.2.3** are to be examined for the possibility that unequal filling levels in transversely paired wing cargo tanks would result in a more onerous stress response. Loading pattern A7 is required to be analysed only if such a non-symmetric seagoing loading conditions is included in the ship loading manual. Loading patterns A7 and A12 need not be examined for tankers without a cross tie arrangement in the centre cargo tanks.

2.3.1.4 For tankers with two oil-tight longitudinal bulkheads, seagoing loading pattern A3 and harbour loading pattern A13, with all cargo tanks abreast empty, are to be analysed with a ship draught of $0.55T_{sc}$ and $0.65T_{sc}$ respectively. If conditions in the ship loading manual specify greater draughts for loading pattern A3 or A13, then the maximum specified draught in the ship's loading manual for the loading pattern is to be used.

2.3.1.5 For tankers with two oil-tight longitudinal bulkheads, seagoing loading pattern A5 and harbour loading pattern A11, with all cargo tanks abreast fully loaded, are to be analysed with a ship draught of $0.8T_{sc}$ and $0.7T_{sc}$ respectively. If conditions in the ship loading manual specify lesser draughts for loading pattern A5 or A11, then the minimum specified draught in the ship's loading manual for the loading pattern is to be used.

2.3.1.6 For loading patterns A1, A2, B1, B2 and B3, with cargo tank(s) empty, a minimum ship draught of $0.9T_{sc}$ is to be used in the analysis. If conditions in the ship loading manual specify greater draughts for loading patterns with empty cargo tank(s), then the maximum specified draught for the actual condition is to be used.

2.3.1.7 Where a ballast condition is specified in the ship loading manual with ballast water filled in one or more cargo tanks, loading patterns A8 and B7 in **Tables B.2.3** and **B.2.4** are to be examined. If this loading is un-symmetrical then additional strength assessment is to be carried out according to the requirements of the individual Classification Society.

Table B.2.3 FE Load Cases for Tankers with Two Oil-tight Longitudinal Bulkheads

Loading Pattern	Figure	Still Water Loads			Dynamic load cases		
		Draught	% of Perm. SWBM ⁽²⁾	% of Perm. SWSF ⁽²⁾	Strength assessment ^(1a)	Strength assessment against hull girder shear loads ^(1b)	
					Midship region	Forward region	Midship and aft regions
Design load combination S + D (Sea-going load cases)							
A1		0.9 T _{sc}	100% (sag)	See note 3	1	\	\
			100% (hog)	100% (-ve fwd) See note 4	2, 5a	\	\
A2		0.9 T _{sc}	100% (sag)	See note 3	1	\	\
			100% (hog)	100% (-ve fwd) See note 4	2, 5a	\	\
A3		0.55 T _{sc} see note 6	100% (hog)	100% (-ve fwd) See note 5	2	4	2
				100% (-ve fwd) See note 4	5a	\	\
A4		0.6 T _{sc}	100% (sag)	100% (+ve fwd) See note 4	1, 5a	\	\
A5		0.8 T _{sc} See note 7	100% (sag)	100% (+ve fwd) See note 5	1	3	1
				100% (+ve fwd) See note 4	5a	\	\
A6		0.6 T _{sc}	100% (hog)	100% (-ve fwd) See note 4	5a	\	\

Table B.2.3 (Continued) FE Load Cases for Tankers with Two Oil-tight Longitudinal Bulkheads

Loading Pattern	Figure	Still Water Loads			Dynamic load cases		
		Draught	Perm. SWBM ⁽²⁾	Perm. SWSF ⁽²⁾	Strength assessment ^(1a)	Strength assessment against hull girder shear loads ^(1b)	
					Midship region	Forward region	Midship and aft regions
A7 ⁽⁸⁾		T_{LC}	100% (hog)	100% (-ve fwd) See note 4	5a	\	\
A8 ⁽⁹⁾		T_{bal-em}	100% (sag)	100% (+ve fwd) See note 4	1	\	\
Design load combination S (Harbour and tank testing load cases)							
A9 ⁽¹³⁾		$\frac{1}{4}T_{sc}$	100% (sag)	100% (+ve fwd) See note 4	Only applicable to strength assessment of midship region (see note 1(a))		
A10 ⁽¹³⁾		$\frac{1}{4}T_{sc}$	100% (sag)	100% (+ve fwd) See note 4	Only applicable to strength assessment of midship region (see note 1(a))		
A11 ^(12,13)		$0.7 T_{sc}$ see note 12	100% (sag)	100% (+ve fwd) See note 5	Applicable to strength assessment of midship region (see 1(a)) and strength assessment against hull girder shear loads (see 1(b))		
A12 ^(10,13)		$\frac{1}{3}T_{sc}$	See note 10	See note 10	Only applicable to strength assessment of midship region (see note 1(a))		
A13 ^(11,13)		$0.65 T_{sc}$ see note 11	100% (Hog)	100% (-ve fwd) See note 5	Applicable to strength assessment of midship region (see 1(a)) and strength assessment against hull girder shear loads (see 1(b))		
A14 ⁽¹³⁾		T_{sc}	100% (Hog)	100% (-ve fwd) See note 4	Only applicable to strength assessment of midship region (see note 1(a))		

Table B.2.3 (Continued) FE Load Cases for Tankers with Two Oil-tight Longitudinal Bulkheads

Notes:

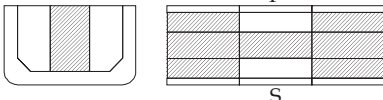
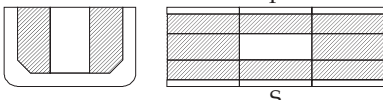
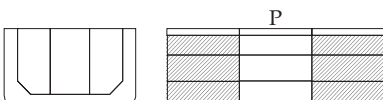
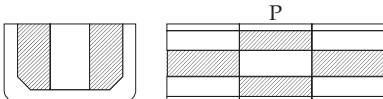
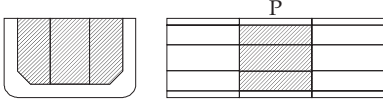
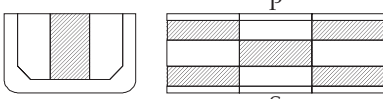
- 1.
- (a) For the assessment of scantlings of longitudinal hull girder structural members, primary supporting structural members and transverse bulkheads within midship cargo region, see **1.1.1.5**.
- (b) For the assessment of strengthening of longitudinal hull girder shear structural members in way of transverse bulkheads for hull girder vertical shear loads, see **1.1.1.6**, **1.1.1.7** and **1.1.1.8**.
2. The selection of permissible SWBM and SWSF for the assessment of different cargo regions of the ship is to be in accordance with **Table B.2.6**. The percentage of the permissible SWBM and SWSF to be applied are to be in accordance with this table.
3. The actual shear force that results from the application of static and dynamic local loads to the FE model are to be used.
4. The actual shear force that results from the application of static and dynamic local loads to the FE model are to be used. Where this shear force exceeds the target SWSF (design load combination S) or target combined SWSF and VWSF, calculated in accordance with **2.4.5.2**, (design load combination S+D) as specified in the table, correction vertical loads are to be applied to adjust the shear force down to the required value.
5. Correction vertical loads are to be applied to adjust the shear force to the required value specified.
6. For loading pattern A3, with all cargo tanks abreast empty in sea-going condition, a draught of $0.55T_{sc}$ is to be used in the analysis. Where such conditions are specified in the ship's loading manual with a draught greater than $0.55T_{sc}$, the maximum specified draught for those loading conditions is to be used in the FE analysis.
7. For loading pattern A5, with all cargo tanks abreast fully loaded in sea-going condition, a draught of $0.8T_{sc}$ is to be used in the analysis. Where such conditions are specified in the ship's loading manual with a draught lesser than $0.8T_{sc}$, the minimum specified draught for those loading conditions is to be used in the FE analysis.
8. Loading pattern A7 is only required to be analysed for tankers with a cross tie arrangement in the centre cargo tanks if the ship's loading manual includes a non-symmetrical loading condition with only one of the wing tanks filled. The actual draught from the loading manual for the condition is to be used in the analysis, see **Table B.2.5**.
9. Ballast loading pattern A8 with ballast filled in one or more cargo tanks (i.e. gale ballast/emergency ballast conditions etc.) is only required to be analysed if the condition is specified in the ship's loading manual. The actual loading pattern and draught from the loading manual for the condition is to be used in the analysis, see **Table B.2.5**.
10. Loading patterns A12 is only required for tankers with a cross tie arrangement in the centre cargo tanks. The actual shear force and bending moment that results from the application of local loads to the FE model are to be used. Adjusting vertical loads and bending moments are not applied.
11. For loading pattern A13, with all cargo tanks abreast empty in harbour condition, a draught of $0.65T_{sc}$ is to be used in the analysis. Where such conditions are specified in the ship's loading manual with a draught greater than $0.65T_{sc}$, the maximum specified draught for those loading conditions is to be used in the FE analysis.
12. For loading pattern A11, with all cargo tanks abreast fully loaded in harbour condition, a draught of $0.7T_{sc}$ is to be used in the analysis. Where such conditions are specified in the ship's loading manual with a draught less than $0.7T_{sc}$, the minimum specified draught for those loading conditions is to be used in the FE analysis.
13. No dynamic loads are to be applied to Design Load Combination S (harbour and tank testing load cases).

Table B.2.4 Load Cases for Tankers with One Centreline Oil-tight Longitudinal Bulkhead

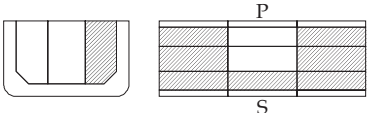
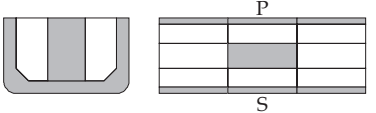
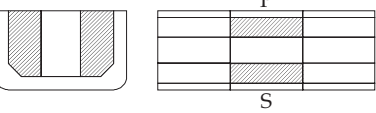
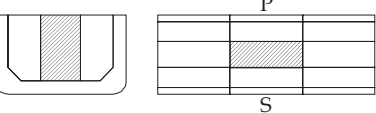
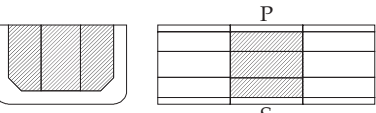
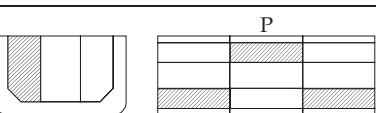
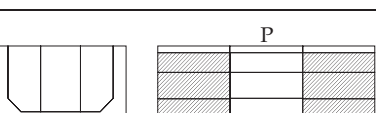
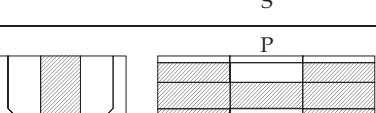
Loading Pattern	Figure	Still Water Loads			Dynamic load cases		
		Draught	% of Perm. SWBM ⁽²⁾	% of Perm. SWSF ⁽²⁾	Strength assessment ^(1a)	Strength assessment against hull girder shear loads ^(1b)	
					Midship region	Forward region	Midship and aft regions
Design load combination S + D (Sea-going load cases)							
B1		$0.9 T_{sc}$	100% (sag)	See note 3	1	\	\
			100% (hog)	100% (-ve fwd) See note 4	2, 5a	\	\
B2 ⁽⁶⁾		$0.9 T_{sc}$	100% (sag)	See note 3	1	\	\
			100% (hog)	100% (-ve fwd) See note 4	2, 5b	\	\
B3		$0.9 T_{sc}$	100% (hog)	100% (-ve fwd) See note 5	2	4	2
				100% (-ve fwd) See note 4	5a, 5b, 6a, 6b	\	\
B4		$0.6 T_{sc}$	100% (sag)	75% (+ve fwd) See note 4	1, 5a	\	\
B5 ⁽⁶⁾		$0.6 T_{sc}$	100% (sag)	75% (+ve fwd) See note 4	1, 5b	\	\
B6		$0.6 T_{sc}$	100% (sag)	100% (+ve fwd) See note 5	1	3	1
				100% (+ve fwd) See note 4	5a, 5b	\	\
B7 ⁽⁷⁾		T_{bal-em}	100% (sag)	100% (+ve fwd) See note 4	1	\	\
Design load combination S (Harbour and tank testing load cases)							
B8 ⁽⁸⁾		$1/3 T_{sc}$	100% (sag)	100% (+ve fwd) See note 5	Applicable to strength assessment of midship region (see 1(a)) and strength assessment against hull girder shear loads (see 1(b))		
B9 ⁽⁸⁾		$1/3 T_{sc}$	100% (sag)	75% (+ve fwd) See note 4	Only applicable to strength assessment of midship region (see note 1(a))		

Table B.2.4 (Continued) Load Cases for Tankers with One Centreline Oil-tight Longitudinal Bulkhead

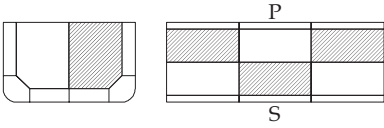
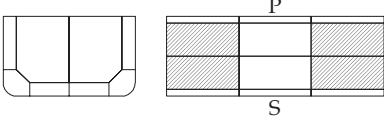
Loading Pattern	Figure	Still Water Loads			Dynamic load cases		
		Draught	Perm. SWBM ⁽²⁾	Perm. SWSF ⁽²⁾	Strength assessment ^(1a)	Strength assessment against hull girder shear loads ^(1b)	
					Midship region	Forward region	Midship and aft regions
B10 ^(6, 8)		$1/3T_{sc}$	100% (sag)	75% (+ve fwd) See note 4	Only applicable to strength assessment of midship region (see note 1(a))		
B11 ⁽⁸⁾		T_{sc}	100% (Hog)	100% (-ve fwd) See note 5	Applicable to strength assessment of midship region (see 1(a)) and strength assessment against hull girder shear loads (see 1(b))		

Notes:

1.
 - (a) For the assessment of scantlings of longitudinal hull girder structural members, primary supporting structural members and transverse bulkheads within midship region, see **1.1.1.5**.
 - (b) For the assessment of strengthening of longitudinal hull girder shear structural members in way of transverse bulkheads for hull girder vertical shear loads, see **1.1.1.6**, **1.1.1.7** and **1.1.1.8**.
2. The selection of permissible SWBM and SWSF for the assessment of different cargo regions of the ship is to be in accordance with **Table B.2.6**. The percentage of the permissible SWBM and SWSF to be applied are to be accordance with this table.
3. The actual shear force that results from the application of static and dynamic local loads to the FE model are to be used.
4. The actual shear force that results from the application of static and dynamic local loads are to be used. Where this shear force exceeds the target SWSF (design load combination S) or target combined SWSF and VWSF, calculated in accordance with **2.4.5.2**, (design load combination S+D) as specified in the table, correction vertical loads are to be applied to adjust the shear force down to the required value.
5. Correction vertical loads are to be applied to adjust the shear force to the required value specified.
6. Load cases B2, B5 and B10 are only required if the structure is not symmetrical about the ship's centreline.
7. Ballast loading pattern B7 with ballast filled in cargo tanks (i.e. gale ballast/emergency ballast conditions etc.) is only required to be analysed if the condition is specified in the ship's loading manual. The actual loading pattern and draught from the loading manual for the condition is to be used in the analysis, see **Table B.2.5**. If the actual loading pattern is different from load case B7 then:
 - (a) An operational restriction corresponding to the analysed condition is to be added in the Loading Manual.
 - (b) 100% of the permissible SWBM is to be applied when analyzing loading pattern with ballast in cargo tanks.
8. No dynamic loads are to be applied to Design Load Combination S (harbour and tank testing load cases).

2.3.2 Dynamic load cases

2.3.2.1 The dynamic load cases to be used for the finite element analysis are specified in **Section 7/6.4**.

2.4 Application of Loads

2.4.1 General

2.4.1.1 The application of loads to the finite element model is to be in accordance with **Section 7/6** and the requirements specified in **B/2.4**.

2.4.1.2 The load parameters and locations to be used for the calculation of the applied loads and accelerations are to be in accordance with **Table B.2.5** and **Table B.2.6**.

2.4.1.3 Constant pressure load, evaluated at the element's centroid, may be applied to a finite plate element. Alternately, a linear pressure distribution between the element's nodal points can be applied.

Table B.2.5 Parameters for Calculation of Loads and Accelerations

Parameter	Standard Conditions			Optional Conditions	
	Draught T_{sc}	Draught $0.9T_{sc}$	Draught $0.6T_{sc}$	Loaded conditions: A3 (draught > $0.6T_{sc}$) and A7	Gale/emergency ballast conditions: A8 and B7
L_{CSR-T}	Rule Length			Rule Length	
C_b	block coefficient, as defined in Section 4/1.1.9.1			block coefficient, as defined in Section 4/1.1.9.1	
Ship speed	0.0			0.0	
Roll response					
GM	0.12B	0.12B	0.24B	Corrected GM in the ship's loading manual for the loaded or gale/emergency ballast pattern under consideration, see Note 1	
$r_{roll-gyr}$	0.35B	0.35B	0.4B	See Note 2	
Pitch response, longitudinal and transverse accelerations, horizontal wave bending moment and sea pressures					
Ship draught	T_{sc}	$0.9T_{sc}$	$0.6T_{sc}$	Maximum mean draught in the loading manual for the loading pattern under consideration	Minimum mean draught in the loading manual for the loading pattern under consideration

Notes:

1. Where GM for optional loaded or gale/emergency ballast conditions is not given in the ship's loading manual, GM is to be determined in accordance with **Section 7/3.1.3.2**.
2. Where $r_{roll-gyr}$ for optional loaded or gale/emergency ballast conditions is not given in the ship's loading manual, $r_{roll-gyr}$ is to be determined in accordance with **Section 7/3.1.3.3**.
3. A gale/emergency ballast condition is defined as a ballast condition with one or more cargo tanks filled with ballast.

Table B.2.6 Locations for the Determination of Loads and Accelerations

	Strength assessment ^(1a)	Strength assessment against hull girder shear loads ^(1b)		
	Midship cargo region	Forward cargo region	Midship cargo region	Aft cargo region
Design load combinations S + D (Sea-going load cases)				
Dynamic wave pressure and green sea load	Transverse section at $0.5L_{CSR-T}$ from AP	Transverse section at $0.75L_{CSR-T}$ from AP	Transverse section at $0.5L_{CSR-T}$ from AP	Transverse section at $0.25L_{CSR-T}$ from AP
Acceleration a_v, a_p, a_{lng}	at CG position of midship tanks (i.e. $0.5L_{CSR-T}$ from AP is within the tank boundary)	at CG position of forward tanks (i.e. $0.75L_{CSR-T}$ from AP is within the tank boundary)	at CG position of midship tanks (i.e. $0.5L_{CSR-T}$ from AP is within the tank boundary)	at CG position of aft tanks (i.e. $0.25L_{CSR-T}$ from AP is within the tank boundary)
VWBM and SWBM (SWBM is to be based on sea-going permissible values, as defined in Section 7/2.1.1 and 2.1.2)	at $0.5L_{CSR-T}$ from AP	at $0.75L_{CSR-T}$ from AP	at $0.5L_{CSR-T}$ from AP	at $0.25L_{CSR-T}$ from AP
HWBM	at $0.5L_{CSR-T}$ from AP	\	\	\
VWSF and SWSF (SWSF is to be based on sea-going permissible values, as defined in Section 7/2.1.3 and 2.1.4)	at the transverse bulkhead with maximum combined seagoing permissible SWSF and VWSF in the region (see 1.1.1.5)	at the transverse bulkhead with maximum combined seagoing permissible SWSF and VWSF in the region (see 1.1.1.6) or at individual bulkhead position (see 1.1.1.8)	based on midship cargo tank strength assessment (see 1.1.1.7) or seagoing permissible SWSF and VWSF at individual transverse bulkhead position (see 1.1.1.8)	
Design load combination S (Harbour and tank testing load cases)				
SWBM (SWBM is to be based on harbour permissible values, as defined in Section 7/2.1.1 and 2.1.2)	at $0.5L_{CSR-T}$ from AP	at $0.75L_{CSR-T}$ from AP	at $0.5L_{CSR-T}$ from AP	at $0.25L_{CSR-T}$ from AP
SWSF (SWSF is to be based on harbour permissible values, as defined in Section 7/2.1.3 and 2.1.4)	maximum harbour permissible SWSF in the region (see 1.1.1.5)	maximum harbour permissible SWSF in the region (see 1.1.1.6) or at individual bulkhead position (see 1.1.1.8)	based on midship cargo tank strength assessment (see 1.1.1.7) or harbour permissible SWSF at individual transverse bulkhead position (see 1.1.1.8)	

Notes:

1. The following assessments are to be carried out:
 - (a) for the assessment of scantlings of longitudinal hull girder structural members, primary supporting structural members and transverse bulkheads in tanks within midship cargo region, see **1.1.1.5**
 - (b) for the assessment of strengthening of longitudinal hull girder shear structural members in way of individual transverse bulkheads for hull girder shear loads, see **1.1.1.6**, **1.1.1.7** and **1.1.1.8**.
2. For each FE load case, accelerations are to be calculated at the centre of gravity position of the ballast and/or cargo in accordance with this table. The acceleration calculated for each reference tank is to be applied to the 3 corresponding cargo or ballast tanks along the length of the FE model.
3. Longitudinal distances used in the calculation of loads refer to distance measured forward from the AP., as defined in **Section 4/1.1.12**
4. Dynamic wave pressure calculated at the specified section is to be applied to the full length of the FE model
5. Dynamic load combination factors applied to dynamic loads for design load combination S + D (sea-going load cases) as defined in **Section 7/6.4**.
6. The SWBM and SWSF to be applied are to be in accordance with **Tables B.2.3** and **B.2.4**.

2.4.2 Structural weight, cargo and ballast density

2.4.2.1 The design cargo density is to be taken as 1.025 tonnes/m^3 , see **2.4.7.2**.

2.4.2.2 The density of sea water is to be taken as 1.025 tonnes/m^3 .

2.4.2.3 The weight of the structure is to be included in the FE analysis. The density of steel is to be taken as 7.85 tonnes/m^3 .

2.4.3 Static sea pressure

2.4.3.1 The static sea pressure applied to a plate element due to draught immersion is to be calculated in accordance with **Section 7/2.2.2**.

2.4.3.2 The still water draught to be considered for each finite element load case is to be in accordance with **Tables B.2.3** and **B.2.4**. A constant draught is to be applied over the full length of the cargo tank FE model.

2.4.3.3 The static sea pressure due to immersed draught for the ship in an upright condition is to be applied for all finite element load cases. The static sea pressure change due to rolling of the ship is included in the dynamic wave pressure formulation.

2.4.4 Dynamic wave pressure

2.4.4.1 The dynamic wave pressure distribution is to be determined at a transverse section of the hull at the longitudinal position as defined in **Table B.2.6**. The dynamic wave pressure distribution is to be calculated in accordance with **Section 7/6.3.5**. This pressure distribution is to be applied over the full length of the FE model.

2.4.4.2 The pressure distribution due to green sea load on the weather deck is to be calculated in accordance with **Section 7/6.3.6** at the longitudinal position as defined in **Table B.2.6**. This pressure distribution is to be applied to the weather deck over the full length of the FE model.

2.4.5 Hull girder vertical bending moment and vertical shear force

2.4.5.1 The hull girder vertical bending moment is to reach the following required value, M_{v-targ} , at a section within the length of the middle tank of the three tanks FE model:

$$M_{v-targ} = M_{sw} + M_{wv}$$

Where:

M_{sw} is the still water bending moment to be applied to the FE load case, as specified in **Tables B.2.3** and **B.2.4**.

M_{wv} is the vertical wave bending moment for the dynamic load case under consideration, calculated in accordance with **Section 7/6.3.2**

2.4.5.2 Hull girder vertical shear force is to reach the following required Q_{targ} value at the forward transverse bulkhead position of the middle tank:

$$Q_{targ} = Q_{sw} + Q_{wv}$$

Where:

Q_{sw} is the vertical still water shear force to be applied to the FE load case, as specified in **Tables B.2.3** and **B.2.4**.

Q_{wv} is the vertical wave shear force for the dynamic load case under consideration, calculated in accordance with **Section 7/6.3.4**.

2.4.5.3 The required hull girder vertical bending moment and shear force are to be achieved in the same load case where required by **Tables B.2.3** and **B.2.4**. The procedure to apply the required shear force and bending moment distributions is described in **2.5**.

2.4.6 Hull girder horizontal wave bending moment

2.4.6.1 Hull girder horizontal wave bending moment at a section within the length of the middle tank of the three tanks FE model is to reach the value required by the dynamic load case under consideration, calculated in accordance with **Section 7/6.3.3**.

2.4.6.2 The procedure to adjust the required hull girder horizontal bending moment is described in **2.5**.

2.4.7 Pressure in cargo and ballast tanks

2.4.7.1 The total tank pressure, P_{in} , to be applied at the boundary of a cargo or ballast tank in the finite element analysis is to include the static and dynamic components specified in **Section 7/Table 7.6.1** and **Table B.2.6**.

2.4.7.2 For the seagoing load cases (design combination S + D) the cargo tank pressure is to be taken as:

$$P_{in} = f_{density} (P_{in-tk} + P_{in-dyn}) \quad (kN/m^2)$$

where:

- $f_{density}$: factor for joint probability of occurrence of cargo density and maximum sea state in 25 years design life
 $= \rho_{max-LM} / \rho_{allowable}$
- ρ_{max-LM} : maximum cargo density associated with a full tank from any loading condition in the ship's loading manual. ρ_{max-LM} is not to be taken as less than 0.9 tonnes/m³ for cargo loaded conditions and 1.025 tonnes/m³ for the optional emergency ballast condition (i.e. A8 and B7 in **Tables B.2.3** and **B.2.4** respectively)
- $\rho_{allowable}$: design cargo density associated with a full tank to be taken as 1.025 tonnes/m³ unless a higher density is specified by the builder, see **Section 2/3.1.8.1**
- P_{in-tk} : static tank pressure as given in **Section 7/2.2.3.1**, in kN/m², and with density of fluid in tank equal to the design cargo density, $\rho_{allowable}$
- P_{in-dyn} : simultaneously acting dynamic pressure given in **Section 7/6.3.7.1**, in kN/m², with simplification given in **2.4.7.3** and with density of fluid in tank equal to the design cargo density, $\rho_{allowable}$

2.4.7.3 The envelope vertical acceleration, a_v , at the centre of gravity of tanks is calculated in accordance with **Section 7/3.3.3** with the following simplifications:

- (a) for head sea conditions, a_{roll-z} is taken as 0
- (b) for beam sea conditions, $a_{pitch-z}$ is taken as 0.

2.4.7.4 The vertical, transverse and longitudinal accelerations are to be calculated at the centre of gravity of the abreast tanks at the longitudinal position as specified in **Table B.2.6**. These accelerations are to be applied to all corresponding tanks along the length of the three-tank FE model.

2.4.7.5 The dynamic tank pressure is to be calculated in accordance with **Section 7/6.3.7.1**, also see **Table B.2.6**.

2.4.7.6 For ballast tanks which utilise ballast water exchange by flow-through method, the following are to be considered when calculating tank pressure for seagoing load cases (design combination S + D) as required by **Section 7/Table 7.6.1**:

- Maximum vertical height of the air pipe or overflow pipe, i.e. h_{air} as defined in **Section 7/2.2.3.2** and **Fig. 7.2.3**, of all ballast tanks in the cargo region is to be used in the calculation of the dynamic tank pressure due to vertical acceleration (see **Section 7/6.3.7.1**).
- Maximum value of h_{air} and P_{drop} , as defined in **Section 7/2.2.3.3**, of all ballast tanks in the cargo region are to be used to calculate the static tank pressure.

2.4.7.7 The following are to be considered when calculating the static tank pressure in cargo tanks for harbour/tank testing load cases (design combination S) as required by **Section 7/Table 7.6.1**:

- Maximum h_{air} , as defined in **Section 7/2.2.3.2** and **Fig. 7.2.3**, of all cargo tanks in the cargo region are to be considered in the calculation of $P_{in-test}$, see **Section 7/2.2.3.5**.

2.4.7.8 Where the length of the model is extended beyond the end transverse bulkheads, see **2.2.1.1**, tank pressure is only to be applied to the complete tanks within the model length.

2.4.7.9 Maximum setting of pressure relief valve, P_{valve} , as defined in **Section 7/2.2.3.5** are to be considered in design combination S and S+D as required by **Section 7/Table 7.6.1**.

2.5 Procedure to Adjust Hull Girder Shear Forces and Bending Moments

2.5.1 General

2.5.1.1 The procedure described in this section is to be applied to adjust the hull girder horizontal bending moment, vertical shear force and vertical bending moment distributions on the three cargo tanks FE model to achieve the required values.

2.5.1.2 Vertical distributed loads are applied to each frame position, together with a vertical bending moment applied to the model ends to produce the required value of vertical shear force at both the forward and aft bulkhead of the middle tank of the FE model, and the required value of vertical bending moment at a section within the length of the middle tank of the FE model. The required values are specified in **2.4.5**.

2.5.1.3 A horizontal bending moment is applied to the ends of the model to produce the required target value of horizontal bending moment at a section within the length of the middle tank of the FE model. The required values are specified in **2.4.6**.

2.5.2 Shear force and bending moment due to local loads

2.5.2.1 The vertical shear forces generated by the local loads are to be calculated at the transverse bulkhead positions of the middle tank of the FE model. The maximum absolute shear force at the bulkhead position of the middle tank of the FE model is to be used to obtain the required adjustment in shear forces at the transverse bulkhead, see **2.5.3**. The vertical bending moment distribution generated by the local loads is to be calculated along the length of the middle tank of the three cargo tank FE model. The FE model can be used to calculate the shear forces and bending moments. Alternatively, a simple beam model representing the length of the 3-tank FE model with simply supported ends may be used to determine the shear force and bending moment values.

2.5.2.2 For beam and oblique sea conditions, the horizontal bending moment distribution due to dynamic sea pressure and dynamic tank pressure is to be calculated along the length of the middle tank of the FE model.

2.5.2.3 The following local loads are to be applied for the calculation of hull girder shear forces and bending moments:

- (a) ship structural weight distribution over the length of the 3-tank model (static loads). Where a simple beam model is used, the weight of the structure of each tank can be distributed evenly over the length of the cargo tank. The structural weight is to be calculated based on a thickness deduction of $0.5t_{corr}$, as used in the construction of the cargo tank FE model, see **2.2.1.5**.
- (b) weight of cargo and ballast (static loads)
- (c) static sea pressure, dynamic wave pressure and, where applicable, green sea load. For the Design Load Combination S (harbour/tank testing load cases), only static sea pressure needs to be applied
- (d) dynamic tank pressure load for Design Load Combination S+D (seagoing load cases).

2.5.3 Procedure to adjust vertical shear force distribution

2.5.3.1 The required adjustment in shear forces at the transverse bulkhead positions (ΔQ_{aft} and ΔQ_{fwd} as shown in **Fig. B.2.10**) are to be generated by applying vertical load at the frame positions as shown in **Fig. B.2.11**. It is to be noted that vertical correction loads are not to be applied to any transverse tight bulkheads, any frames forward of the forward tank and any frames aft of the aft tank of the FE model. The sum of the total vertical correction loads applied is equal to zero.

2.5.3.2 The required adjustment in shear forces at the aft and forward transverse bulkheads of the middle tank of the FE model in order to generate the required shear forces at the bulkheads are given by:

$$\Delta Q_{aft} = -Q_{targ} - Q_{aft}$$

$$\Delta Q_{fwd} = Q_{targ} - Q_{fwd}$$

Where:

ΔQ_{aft} : required adjustment in shear force at aft bulkhead of middle tank based on the maximum absolute shear force at the bulkhead

ΔQ_{fwd} : required adjustment in shear force at fore bulkhead of the middle tank based on the maximum absolute shear force at the bulkhead

Q_{targ} : required shear force value to be achieved at forward bulkhead of middle tank, see **2.4.5**.

Q_{aft} : shear force due to local loads at aft bulkhead of middle tank, see **2.5.2**
 Q_{fwd} : shear force due to local loads at fore bulkhead of middle tank, see **2.5.2**

Fig. B.2.10 Position of Target Shear Force and Required Shear Force Adjustment at Transverse Bulkhead Positions

Condition	Target			Aft Bkhd		Fore Bkhd	
	BM	SF	Bkhd pos	SF	ΔQ_{aft}	SF	ΔQ_{fwd}
	Hog	-ve	Fore	$-Q_{targ}$	$-Q_{targ} - Q_{aft}$	$Q_{targ} (-ve)$	$Q_{targ} - Q_{fwd}$
	Hog	-ve	Fore	$-Q_{targ}$	$-Q_{targ} - Q_{aft}$	$Q_{targ} (-ve)$	$Q_{targ} - Q_{fwd}$
	Sag	+ve	Fore	$-Q_{targ}$	$-Q_{targ} - Q_{aft}$	$Q_{targ} (+ve)$	$Q_{targ} - Q_{fwd}$
	Sag	+ve	Fore	$-Q_{targ}$	$-Q_{targ} - Q_{aft}$	$Q_{targ} (+ve)$	$Q_{targ} - Q_{fwd}$

Note:

For definition of symbols, see 2.5.3.2.

Fig. B.2.11 Distribution of Adjusting Vertical Force at Frames and Resulting Shear Force Distributions

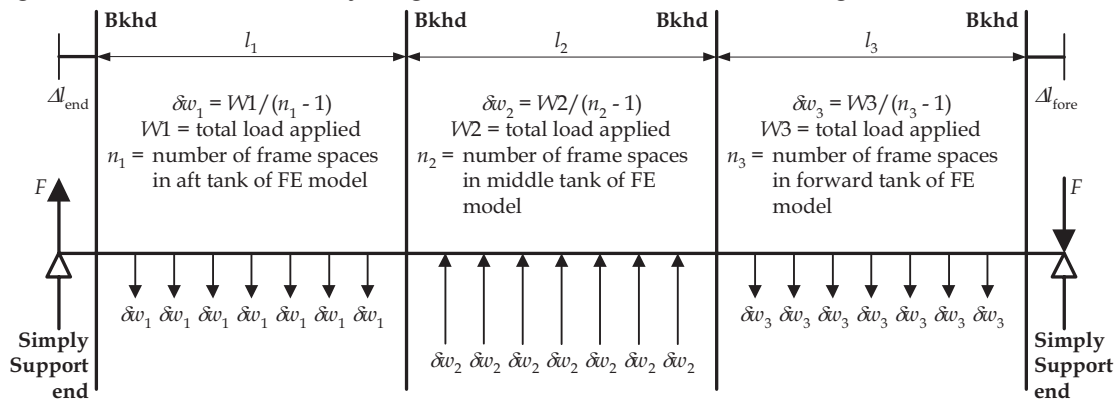

Note: Transverse bulkhead frames not loaded
 Frames beyond aft transverse bulkhead of aft most tank and forward bulkhead of forward most tank not loaded
 F = Reaction load generated by supported ends

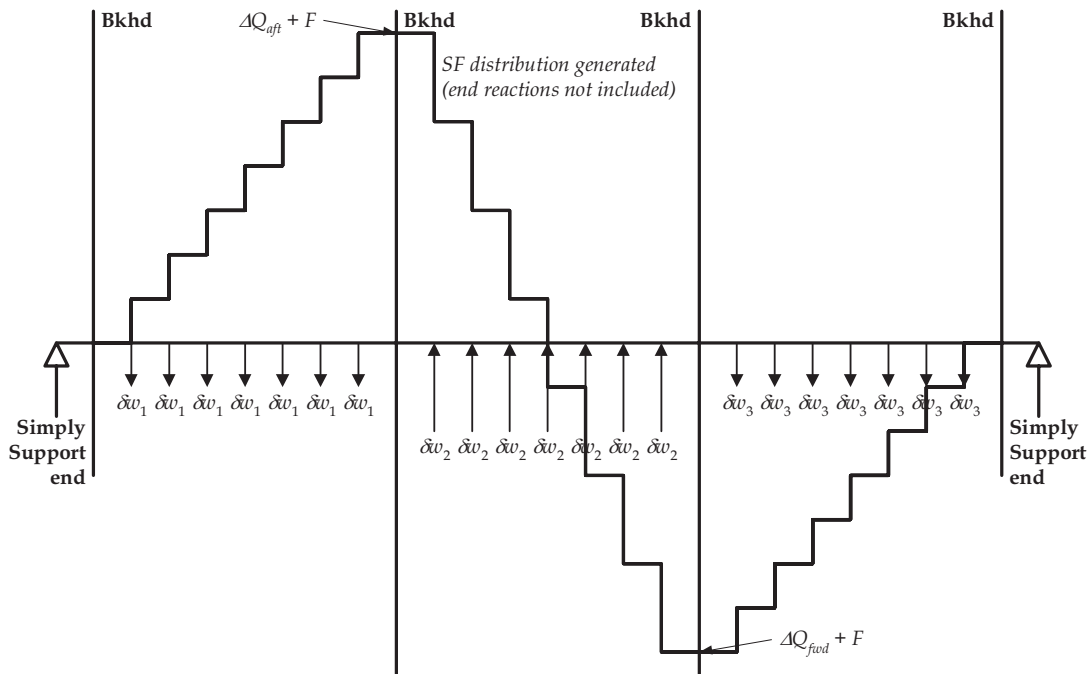

Shear Force distribution due to adjusting vertical force at frames

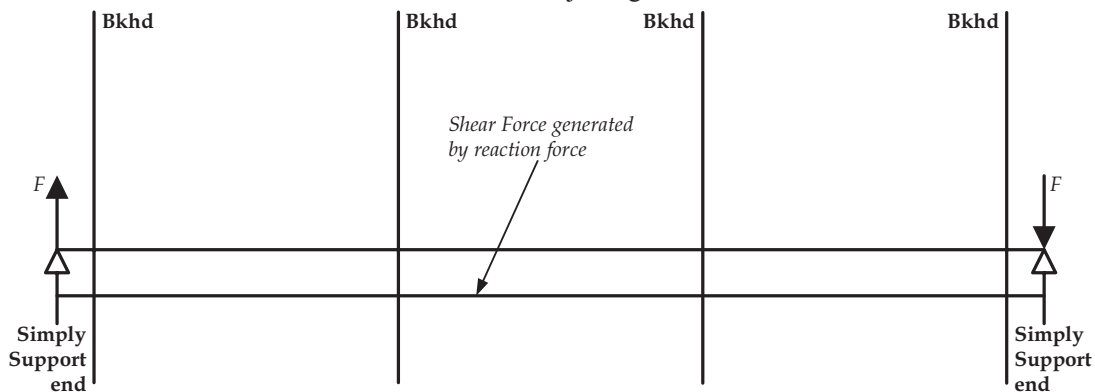

Note: $F = 0$ if $l_1 = l_3$ and $\Delta_{fore} = \Delta_{end}$, and loads are symmetrical about mid-length of model

Note:

For definition of symbols, see **Table B.2.7**.

2.5.3.3 The value of the vertical loads to be applied to each frame to generate the increase in shear force at the bulkheads may be calculated using a simple beam model. For the case where an uniform frame spacing is used within each tank, the amount of vertical force to be distributed at each frame may be calculated in accordance with **Table B.2.7**. The length and frame spacing of individual cargo tanks may be different.

Table B.2.7 Formulae for Calculation of Vertical Loads for Adjusting Vertical Shear Forces

$\delta w_1 = \frac{\Delta Q_{aft} (2l - l_2 - l_3) + \Delta Q_{fwd} (l_2 + l_3)}{(n_1 - 1)(2l - l_1 - 2l_2 - l_3)}$	$F = 0.5 \left(\frac{W1(l_2 + l_1) - W3(l_2 + l_3)}{l} \right)$
$\delta w_2 = \frac{(W1 + W3)}{(n_2 - 1)} = \frac{(\Delta Q_{aft} - \Delta Q_{fwd})}{(n_2 - 1)}$	
$\delta w_3 = \frac{-\Delta Q_{fwd} (2l - l_1 - l_2) - \Delta Q_{aft} (l_1 + l_2)}{(n_3 - 1)(2l - l_1 - 2l_2 - l_3)}$	

Where:

- l_1 : length of aft cargo tank of model
 l_2 : length of middle cargo tank of model
 l_3 : length of forward cargo tank of model
 ΔQ_{aft} : required adjustment in shear force at aft bulkhead of middle tank, see **Fig. B.2.10**
 ΔQ_{fwd} : required adjustment in shear force at fore bulkhead of middle tank, see **Fig. B.2.10**
 F : end reactions due to application of vertical loads to frames, see **2.5.3**
 $W1$: total evenly distributed vertical load applied to aft tank of FE model,
 $(n_1 - 1) \delta w_1$
 $W2$: total evenly distributed vertical load applied to middle tank of FE model,
 $(n_2 - 1) \delta w_2$
 $W3$: total evenly distributed vertical load applied to forward tank of FE model,
 $(n_3 - 1) \delta w_3$
 n_1 : number of frame spaces in aft cargo tank of FE model
 n_2 : number of frame spaces in middle cargo tank of FE model
 n_3 : number of frame spaces in forward cargo tank of FE model
 δw_1 : distributed load at frame in aft cargo tank of FE model
 δw_2 : distributed load at frame in middle cargo tank of FE model
 δw_3 : distributed load at frame in forward cargo tank of FE model
 Δl_{end} : distance between end bulkhead of aft cargo tank to aft end of FE model
 Δl_{fore} : distance between fore bulkhead of forward cargo tank to forward end of FE model
 l : total length of FE model (beam) including portions beyond end bulkheads
 $= l_1 + l_2 + l_3 + \Delta l_{end} + \Delta l_{fore}$

Notes:

1. Positive direction of loads, shear forces and adjusting vertical forces in the formulae is in accordance with **Fig. B.2.10** and **B.2.11**.
2. $W1 + W3 = W2$
3. Note that the above *formulae* are only applicable if an uniform frame spacing is used within each tank, see **2.5.3.3**. The length and frame spacing of individual cargo tanks may be different.

2.5.3.4 The amount of adjusting load to be applied to the structural parts of each transverse frame section to generate the vertical load, δw_i , is to be in accordance with **Fig. B.2.12**. This load is to be distributed at the finite element grid points of the structural parts. Where 4-node or 3-node finite plate elements are used, the load to be applied at each grid point of a plate element is given by:

$$F_{i-grid} = \frac{\sum^n 0.5 A_{i-elem-net50}}{A_{s-net50}} F_s$$

Where:

- F_{i-grid} : load to be applied to the i^{th} FE grid point on the individual structural member under consideration, i.e. side shell, longitudinal bulkheads and bottom girders, inner hull longitudinal bulkheads, hopper plates, upper slope plates of inner hull and outboard girders as defined in **Fig. B.2.12**

- $A_{i-elem-net50}$: sectional area of each plate element in the individual structural

member under consideration (see **Fig. B.2.12**), which is connected to the i^{th} grid point

- n : number of plate elements connected to the i^{th} grid point
- F_s : total load applied to individual structural member under consideration, as specified in **Fig. B.2.12**
- $A_{s-net50}$: plate sectional area of the individual structural member under consideration, i.e. side shell, longitudinal bulkheads, bottom girders, inner hull longitudinal bulkheads, hopper plates, upper slope plates of inner hull and outboard girders as defined in **Fig. B.2.12**

Fig. B.2.12 Distribution of Adjusting Load on a Transverse Section

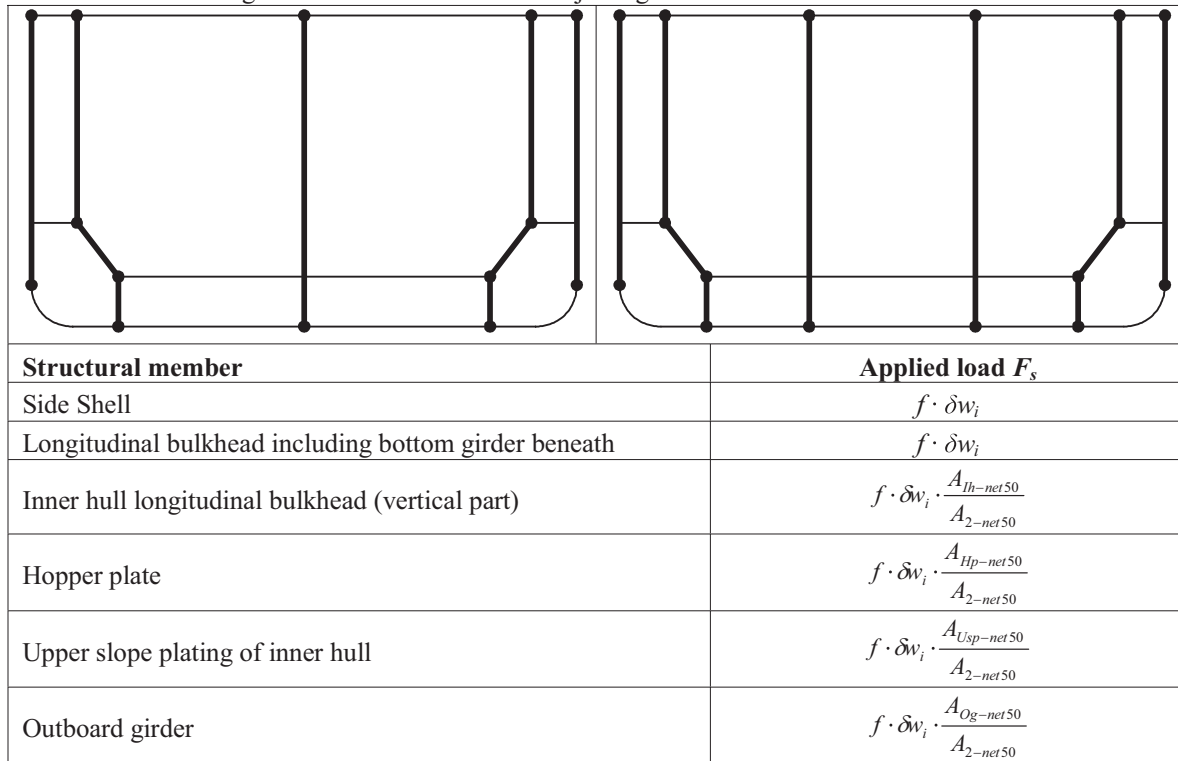

Where

- δw_i : vertical load to be applied to each transverse frame section, see **2.5.3.3** and **Table B.2.7**
- f : shear force distribution factor of structural part calculated at the mid-tank position in accordance with **Table B.2.8**
- $A_{lh-net50}$: plate sectional area of individual inner hull longitudinal bulkhead
- $A_{Hp-net50}$: plate sectional area of individual hopper plate
- $A_{Usp-net50}$: plate sectional area of individual upper slope plate of inner hull
- $A_{Og-net50}$: plate sectional area of individual outboard girder
- $A_{2-net50}$: plate sectional area calculated in accordance with **Table B.2.8**

Notes:

1. Adjusting load is to be applied in plane to the hopper slope plate and upper slope plate of inner hull.
2. Adjusting load given is to be applied to individual structural member.

Table B.2.8 Shear Force Distribution Factors

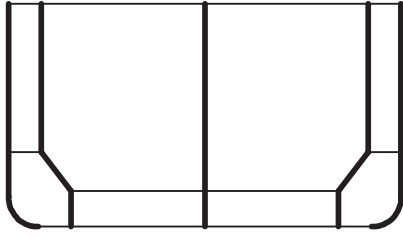
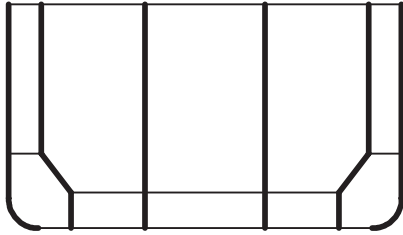
	Side Shell	$f = 0.055 + 0.097 \frac{A_{1-net50}}{A_{2-net50}} + 0.020 \frac{A_{2-net50}}{A_{3-net50}}$
	Inner hull	$f = 0.193 - 0.059 \frac{A_{1-net50}}{A_{2-net50}} + 0.058 \frac{A_{2-net50}}{A_{3-net50}}$
	CL longitudinal bulkhead	$f = 0.504 - 0.076 \frac{A_{1-net50}}{A_{2-net50}} - 0.156 \frac{A_{2-net50}}{A_{3-net50}}$
	Side Shell	$f = 0.028 + 0.087 \frac{A_{1-net50}}{A_{2-net50}} + 0.023 \frac{A_{2-net50}}{A_{3-net50}}$
	Inner hull	$f = 0.119 - 0.038 \frac{A_{1-net50}}{A_{2-net50}} + 0.072 \frac{A_{2-net50}}{A_{3-net50}}$
	Longitudinal bulkhead	$f = 0.353 - 0.049 \frac{A_{1-net50}}{A_{2-net50}} - 0.095 \frac{A_{2-net50}}{A_{3-net50}}$

Where:

- $A_{1-net50}$: plate sectional area of individual side shell (i.e. on one side), including bilge
 $A_{2-net50}$: plate sectional area of individual inner hull longitudinal bulkhead (i.e. on one side), including hopper slope plate, double bottom side girder in way and, where fitted, upper slope plating of inner hull.
 $A_{3-net50}$: plate sectional area of individual longitudinal bulkhead, including double bottom girder in way

Notes:

1. Where part of the structural member is not vertical, the area is to be calculated using the projected area in the vertical direction.
2. All plate areas are to be calculated based on the modelled thickness of the cargo tank FE model, see **2.2.1.5**.
3. For corrugated longitudinal bulkheads, the corrugation thickness for the calculation of shear force distribution factor, f , is to be corrected according to **Section 4/2.6.4**.

2.5.4 Procedure to adjust vertical and horizontal bending moments

2.5.4.1 An additional vertical bending moment is to be applied at both ends of the cargo tank finite element model to generate the required vertical bending moment in the middle tank of the model. This end vertical bending moment can be calculated as follows:

$$M_{v-end} = M_{v-targ} - M_{v-peak}$$

Where:

- M_{v-end} : additional vertical bending moment to be applied at both ends of finite element model
 M_{v-targ} : required hogging (positive) or sagging (negative) vertical bending moment, as specified in **2.4.5**
 M_{v-peak} : maximum or minimum bending moment within the length of the middle tank due to the local loads described in **2.5.2.3** and the additional vertical loads applied to generate the required shear force, see **2.5.3**. M_{v-peak} is to be taken as the maximum bending moment if M_{v-targ} is hogging (positive) and as the minimum bending moment if M_{v-targ} is sagging (negative).

M_{v-peak} can be obtained from FE analysis. Alternatively, M_{v-peak} may be calculated as follows based on a simply supported beam model

$$M_{v-peak} = \text{Max} \{ M_o + xF + M_{inload} \}$$

- M_o : vertical bending moment at position x , due to the local loads described in **2.5.2.3**.
 M_{inload} : vertical bending moment at position x , due to application of vertical line loads at frames to generate required shear force, see **2.5.3**

- F : reaction force at ends due to application of vertical loads to frames, see **2.5.3**
- x : longitudinal position of frame in way of the middle tank of FE model from end, see **2.5.4.2**

2.5.4.2 For beam and oblique sea load cases, an additional horizontal bending moment is to be applied at the ends of the cargo tank FE model to generate the required horizontal bending moment at a section within the length of the middle tank of the model. The additional horizontal bending moment can be calculated as follows:

$$M_{h-end} = M_{h-targ} - M_{h-peak}$$

Where:

- M_{h-end} : additional horizontal bending moment to be applied to ends of FE model
- M_{h-targ} : required positive or negative horizontal bending moment, see **2.4.6**
- M_{h-peak} : maximum or minimum horizontal bending moment within the length of the middle tank due to the local loads described in **2.5.2.3**. M_{h-peak} is to be taken as the maximum horizontal bending moment if M_{h-targ} is positive (starboard side in tension) and as the minimum horizontal bending moment if M_{h-targ} is negative (port side in tension).

2.5.4.3 The vertical and horizontal bending moments should be calculated over the length of the middle tank of the FE model to identify the position and value of each maximum/minimum bending moment as specified in **2.5.4.1** and **2.5.4.2**.

2.5.4.4 The additional vertical bending moment, M_{v-end} , and horizontal bending moment, M_{h-end} , are to be applied to both ends of the cargo tank model. The bending moments may be applied by either of the methods described in **2.5.4.5** and **2.5.4.6**.

2.5.4.5 The vertical and horizontal bending moments may be applied at the model ends by distributing axial nodal forces to all longitudinal elements according to the simple beam theory as follows:

$$(F_x)_i = \frac{M_{v-end}}{I_{y-net50}} \frac{A_{i-net50}}{n_i} z_i \quad \text{for vertical bending moment}$$

$$(F_x)_i = \frac{M_{h-end}}{I_{z-net50}} \frac{A_{i-net50}}{n_i} y_i \quad \text{for horizontal bending moment}$$

Where:

- M_{v-end} : vertical bending moment to be applied to the ends of the model
- M_{h-end} : horizontal bending moment to be applied to the ends of the model
- $(F_x)_i$: axis force applied to a node of the i^{th} element
- $I_{y-net50}$: hull girder vertical moment of inertial of the end section about its horizontal neutral axis
- $I_{z-net50}$: hull girder horizontal moment of inertial of the end section about its vertical neutral axis (normally centreline)
- z_i : vertical distance from the neutral axis to the centre of the cross sectional area of the i^{th} element
- y_i : horizontal distance from the neutral axis to the centre of the cross sectional area of the i^{th} element
- $A_{i-net50}$: cross sectional area of the i^{th} element
- n_i : number of nodal points of i^{th} element on the cross section, $n_i = 2$ for 4-node plate element

2.5.4.6 The vertical and horizontal bending moments may alternatively be applied to an independent grid point at the intersection of the vertical neutral axis (normally centreline) and the horizontal neutral axis, see **Fig. B.2.13**. All nodal points of the longitudinal elements on the end section are to be rigidly linked to the independent point in θ_y (for vertical bending), θ_z (for horizontal bending) and δ_x . This independent point is not to be connected to the model except by the rigid link. The rigid links are to maintain the end plane of the model in keeping plane under the action of the applied bending moment, which is equivalent to imposing a prescribed displacement to the nodal points in accordance with the simple beam theory.

2.6 Boundary Conditions

2.6.1 General

2.6.1.1 All boundary conditions described in this section are in accordance with the global co-ordinate system defined in **Section 4/1.4**. The boundary conditions to be applied at the ends of the cargo tank FE model are given in **Table B.2.9**. The analysis may be carried out by applying all loads to the model as a complete load case or by combining the stress responses resulting from several separate sub-cases.

2.6.1.2 Ground spring elements, i.e. spring elements with one end constrained in all 6 *degrees* of freedom, with stiffness in global y degree of freedom are to be applied to the grid points along deck, inner bottom and bottom shell as shown in **Fig. B.2.13**.

2.6.1.3 Ground spring elements with stiffness in global z degree of freedom are to be applied to the grid points along the vertical part of the side shells, inner hull longitudinal bulkheads and oil-tight longitudinal bulkheads as shown in **Fig. B.2.13**.

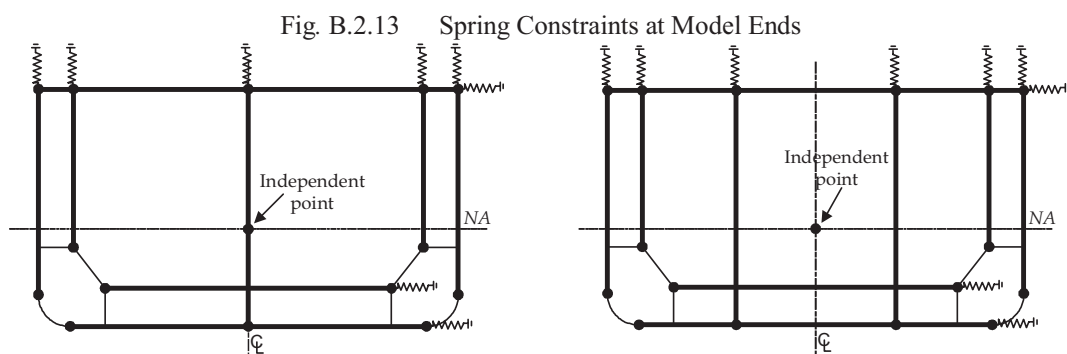

Table B.2.9 Boundary Constraints at Model Ends

Location	Translation			Rotation		
	δ_x	δ_y	δ_z	θ_x	θ_y	θ_z
Aft End						
Aft end (all longitudinal elements)	<i>RL</i>	-	-	-	<i>RL</i>	<i>RL</i>
Independent Point aft end, see Fig. B.2.13	Fix	-	-	-	M_{v-end}	M_{h-end}
Deck, inner bottom and outer shell	-	Springs	-	-	-	-
Side, inner skin and longitudinal bulkheads	-	-	Springs	-	-	-
Fore End						
Fore end (all longitudinal elements)	<i>RL</i>	-	-	-	<i>RL</i>	<i>RL</i>
Independent point fore end, see Fig. B.2.13	-	-	-	-	M_{v-end}	M_{h-end}
Deck, inner bottom and outer shell	-	Springs	-	-	-	-
Side, inner skin and longitudinal bulkheads	-	-	Springs	-	-	-

Where:

- : no constraint applied (free)

RL : nodal points of all longitudinal elements rigidly linked to independent point at neutral axis on centreline

Notes:

1. All translation and rotation displacements are in accordance with the global coordinate system defined in **Section 4/1.4**.
2. Where M_{h-end} is not applied, the independent points at the fore and aft ends are to be free in θ_z .
3. Where M_{v-end} is not applied, the independent points at the fore and aft ends are to be free in θ_y .
4. Where no bending moment is applied, the independent points at the fore and aft ends are to be free in θ_y and θ_z .
5. Where bending moment is applied as nodal forces, the independent points at the fore and aft ends are to be free in the corresponding degree of freedom of rotations (i.e. θ_y and/or θ_z).

2.6.2 Calculation of spring stiffness

2.6.2.1 The stiffness, c , of individual spring elements for each structural member, to be applied at each end of the cargo tank model, is given by:



$$c = \left(\frac{E}{1 + \nu} \right) \frac{A_{s-net50}}{l_{tk} n} = 0.77 \frac{A_{s-net50} E}{l_{tk} n} \quad (N/mm)$$

Where:

$A_{s-net50}$: shearing area of the individual structural member under consideration, i.e. plating of deck, inner bottom, bottom shell, side shell, inner hull longitudinal bulkheads or oil-tight longitudinal bulkhead. $A_{s-net50}$ is to be calculated based on the thickness of the cargo tank finite element model for areas indicated in **Table B.2.10** for the appropriate structural member under consideration, in mm^2

- ν : Poisson's ratio of the material
- l_{tk} : length of cargo tank, between bulkheads of the middle tank of the FE model, in mm^2
- E : Modulus of Elasticity, in N/mm^2
- n : number of nodal points to which the spring elements are applied to the structural member under consideration

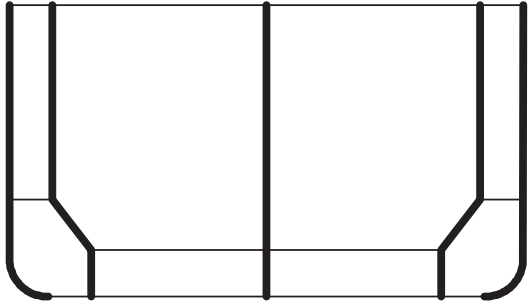
Table B.2.10 Shear Areas to be Considered for the Calculation of Spring Stiffness

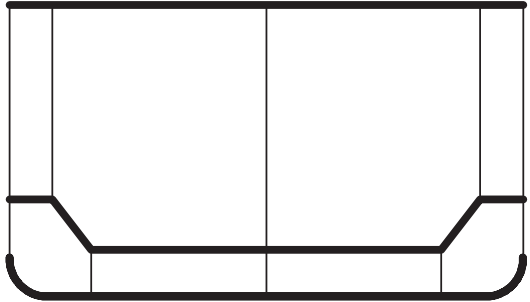
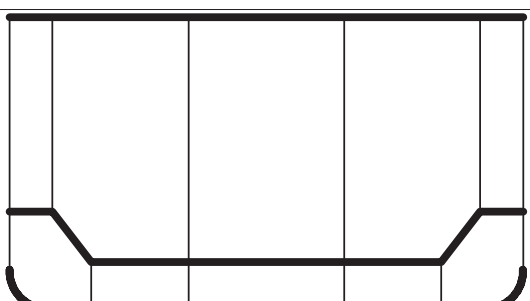
Vertical springs							
	<table style="width: 100%; border: none;"> <tr> <td style="width: 20%; padding: 2px 5px;">Side</td> <td style="padding: 2px 5px;">Area of side shell plating, including bilge</td> </tr> <tr> <td style="padding: 2px 5px;">Inner hull longitudinal bulkheads</td> <td style="padding: 2px 5px;">Area of inner skin plating, including hopper slope plate and double bottom side girder in way</td> </tr> <tr> <td style="padding: 2px 5px;">Longitudinal bulkheads</td> <td style="padding: 2px 5px;">Area of longitudinal bulkhead plating, including double bottom girder in way</td> </tr> </table>	Side	Area of side shell plating, including bilge	Inner hull longitudinal bulkheads	Area of inner skin plating, including hopper slope plate and double bottom side girder in way	Longitudinal bulkheads	Area of longitudinal bulkhead plating, including double bottom girder in way
Side	Area of side shell plating, including bilge						
Inner hull longitudinal bulkheads	Area of inner skin plating, including hopper slope plate and double bottom side girder in way						
Longitudinal bulkheads	Area of longitudinal bulkhead plating, including double bottom girder in way						
	<p>Note</p> <p>Where part of the structural member is not vertical, the area is to be calculated using the projected area in the vertical direction.</p>						
Horizontal springs							
	<table style="width: 100%; border: none;"> <tr> <td style="width: 20%; padding: 2px 5px;">Deck</td> <td style="padding: 2px 5px;">Area of deck plating</td> </tr> <tr> <td style="padding: 2px 5px;">Inner bottom</td> <td style="padding: 2px 5px;">Area of inner bottom plating, including hopper slope plate and horizontal stringer in way</td> </tr> <tr> <td style="padding: 2px 5px;">Bottom shell</td> <td style="padding: 2px 5px;">Area of bottom shell plating, including bilge</td> </tr> </table>	Deck	Area of deck plating	Inner bottom	Area of inner bottom plating, including hopper slope plate and horizontal stringer in way	Bottom shell	Area of bottom shell plating, including bilge
Deck	Area of deck plating						
Inner bottom	Area of inner bottom plating, including hopper slope plate and horizontal stringer in way						
Bottom shell	Area of bottom shell plating, including bilge						
	<p>Note:</p> <p>Where part of the structural member is not horizontal the area is to be calculated using the projected area in the horizontal direction.</p>						

2.6.2.2 For vertical corrugated longitudinal bulkheads, the corrugation thickness for the calculation of spring stiffness, c , shall be calculated according to **Section 4/2.6.4**.

2.6.2.3 Alternatively, rod elements may be used instead of spring elements, the equivalent cross section area of the rod is $(c \cdot l)/E$, where l is the length of the rod. One end of the rod is to be constrained in all 6 degrees of freedom.

2.7 Result Evaluation

2.7.1 General

2.7.1.1 Verification of result against acceptance criteria is to be carried out for structural members within longitudinal extent shown in **Fig. B.2.14**, which includes the middle tanks of the three cargo tanks FE model and the region forward and aft of the middle tanks up to the extent of the transverse bulkhead stringer and buttress structure. For the strength assessment of tanks in the midship cargo region, stress level and buckling capability of longitudinal hull girder structural members, primary supporting structural members and transverse bulkheads are to be verified. For the assessment of required strengthening in way of transverse bulkheads against hull girder shear load, stress level and buckling capability of inner hull longitudinal bulkheads including upper sloped plate where fitted, side shell, hopper, bottom girders and longitudinal bulkheads are to be verified.

2.7.1.2 Assessment of results is to be carried out for the standard load cases specified in **2.3.1**, and any other load cases specially considered as required by **Section 9/2.2.3**.

Fig. B.2.14 Extent of FE Model for Verification against Acceptance Criteria

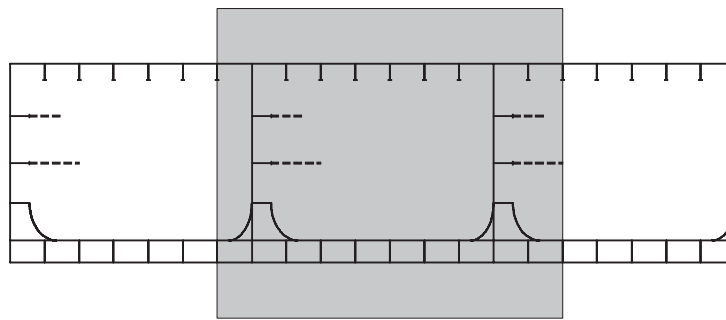

2.7.2 Stress assessment

2.7.2.1 Stresses are not to exceed the permissible values given in **Section 9/2.2.5**.

2.7.2.2 The maximum permissible stresses are based on the mesh sizes and element types described in **2.2**.

2.7.2.3 The von Mises stress, σ_{vms} , is to be calculated based on the membrane direct and shear stresses of the plate element. Where shell elements are used, the stresses are to be evaluated at the mid plane of the element. Where plate elements are used, the stresses are to be evaluated at the element centroid.

2.7.2.4 Except as indicated in **2.7.2.5**, the element shear stress in way of openings in webs is to be corrected for loss in shear area in accordance with the following formula. The corrected element shear stress is to be used to calculate the von Mises stress of the element for verification against the acceptance criteria.

$$\tau_{cor} = \frac{h t_{mod-net50}}{A_{s-net50}} \tau_{elem}$$

Where:

- τ_{cor} : corrected element shear stress
- h : height of web of girder in way of opening, see **Fig. B.2.8**. Where the geometry of the opening is modelled, h is to be taken as the net height with the height of the modelled opening deducted.
- $t_{mod-net50}$: modelled web thickness in way of opening, see **Table B.2.2**.
- $A_{s-net50}$: actual effective shear area of web, including area lost due to slots for stiffeners, calculated in accordance with **Section 4/2.5**. The thickness of the web is to be based on net thickness obtained by deducting $0.5t_{corr}$ from the gross thickness
- τ_{elem} : element shear stress before correction

2.7.2.5 Correction of element shear stress due to presence of openings is not required provided that:

- (a) all slots for local support stiffeners are fitted with lugs or collar plates;

- (b) the difference between the modelled shear area of the plate and the actual effective shear area, $A_{s-net50}$ calculated in accordance with **Section 4/2.5.1**, is less than 20% of the modelled shear area, and
- (c) the yield utilisation factor is less than 80% of the permissible yield utilisation factor given in **Section 9/Table 9.2.1**.

2.7.2.6 Where the corrugation is not modelled with its exact geometric shape, the corrected axial stress in the flange of the corrugation, σ_{fl-act} , is to be taken as the greater of:

$$\sigma_{fl-act} = \sigma_{fl-FEM} \frac{Z_{corr-FEM-net50}}{Z_{corr-act-net50}} \frac{l_{corr-act}}{l_{corr-FEM}}$$

$$\sigma_{fl-act} = \sigma_{fl-FEM}$$

Where:

σ_{fl-FEM} : axial stress obtained from the finite element analysis, see **Fig. B.2.15**

$Z_{corr-FEM-net50}$: section modulus of the modelled corrugation calculated in accordance with **Fig. B.2.15**

$Z_{corr-act-net50}$: section modulus of the actual corrugation calculated in accordance with **Fig. B.2.15**

$l_{corr-act}$: length of corrugation section, as given in **Fig. B.2.15**

$l_{corr-FEM}$: length of corrugation section, as given in **Fig. B.2.15**

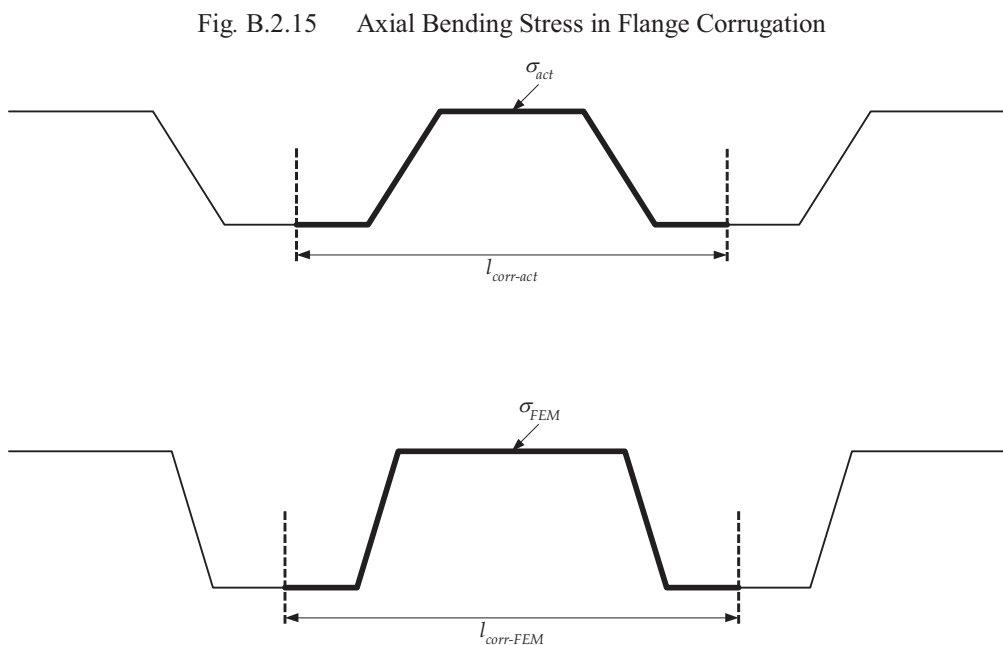

Note:

$l_{corr-act}$ = length of corrugation section, for the calculation of $Z_{corr-act-net50}$

$l_{corr-FEM}$ = length of corrugation section, for the calculation of $Z_{corr-FEM-net50}$

2.7.3 Buckling assessment

2.7.3.1 Buckling capability is to be assessed for the plating and stiffened panels of longitudinal hull girder structural members, primary support members and transverse bulkheads, including deck, double side, side, bottom, double bottom, hopper, transverse and vertical web frames, stringers, transverse and longitudinal bulkhead structures. Buckling capability of curved panels (e.g. bilge), face plate of primary support members and tripping brackets is not assessed based on stress result obtained by the finite element analysis.

2.7.3.2 The utilisation factor against buckling for all plates and stiffened panels is not to exceed the permissible values given in **Section 9/2.2.5**. The method for carrying out buckling assessment of plates and stiffened panels is described in **Appendix D/5**.

2.7.3.3 The buckling assessment is to be based on the stresses obtained from the finite element analysis in conjunction with buckling capacity model based on net thickness obtained by deducting the full corrosion addition, t_{corr} , and any Owner's extras from the proposed thickness. This thickness deduction applies to all plating, stiffener webs and face plates.

2.7.3.4 The buckling assessment is to be based on membrane stress evaluated at the centroid of the plate elements. Where shell elements are used, stresses at the mid plane of the element are to be used for the buckling assessment.

2.7.3.5 The combined interaction of bi-axial compressive stresses, shear stress and lateral pressure loads are to be considered in the buckling calculation. Where a stress correction is to be applied to the finite element stresses as required by **2.7.2**, the buckling assessment is to be based on the corrected stresses.

2.7.3.6 For tankers with a cross tie arrangement, the pillar buckling capability of the cross tie structure is to be assessed based on the buckling formulae given in **Section 10/3.5.1**. The average axial compressive stress at the mid span of the cross tie in the ship's transverse direction, weighted by cross section area, is to be used for the buckling assessment.

2.7.3.7 In the absence of a suitable advanced buckling method described in **Appendix D/5** for the modelling of bulkhead corrugation, assessment of local buckling of unit corrugation flanges is to be in accordance with **Section 10/3.5.2** and criteria given in **Section 9/2.2.5**. The assessment is to be based only on uni-axial stress (membrane stress evaluated at element centroid) parallel to the corrugation knuckles. Averaged stress between elements is not to be used. For the part of the corrugated plate flange from the lower bulkhead stool top to a level of $s/2$ above, where s is the breadth of the flange, the stress used for the buckling assessment needs not be taken as greater than the value obtained at $s/2$ above the bulkhead stool top. The stress value at $s/2$ may be obtained by interpolation if the stress value cannot be obtained directly from a plate element.

2.7.3.8 In the absence of a suitable advanced buckling assessment method described in **Appendix D/5** for the modelling of panel with opening, local buckling of web plates of primary support members in way of openings is to be assessed in accordance with **Section 10/3.4** based on acceptance criteria on buckling utilisation factor given in **Section 9/2.2.5**. The assessment is to be based on FE membrane stress evaluated at the centroid of plate elements. Stresses in the area of the web required for buckling assessment are to be obtained as averaged stresses of the plate elements within the required area. Stress obtained from either the cargo tank analysis or local fine mesh analysis may be used for the assessment. Where the effect of opening is not taken into account in the cargo tank analysis, the stresses obtained from the finite element analysis are to be corrected in accordance with **2.7.2.4** and **2.7.2.5**.

3. Local Fine Mesh Structural Strength Analysis

3.1 General

3.1.1 Application

3.1.1.1 For tankers of conventional arrangements, finite element fine mesh analysis of structural details is to be in accordance with the requirements given in this section.

3.1.1.2 Additional requirements of fine mesh analysis are to be in accordance with **Section 9/2.3.1.3** and **Section 9/2.3.1.4**.

3.1.2 Transverse web frame and wash bulkhead

3.1.2.1 Upper hopper knuckle connections as indicated in **Fig. B.3.1** are to be evaluated by fine mesh analysis on a typical transverse web frame in the middle tank of the cargo tank model. Main bracket toes and openings as indicated in **Fig. B.3.1** are to be evaluated by fine mesh analysis if the screening criteria given in **3.1.6** are not complied with.

3.1.2.2 Where a wash bulkhead is fitted, main bracket toes and openings of the transverse and vertical webs as indicated in **Fig. B.3.1** are to be evaluated by fine mesh analysis if the screening criteria given in **3.1.6** are not complied with.

3.1.2.3 The web frame which indicates highest von Mises stresses in way of each structural detail from the cargo tank analysis is to be selected for the fine mesh analysis.

Fig. B.3.1 Areas Requiring Consideration for Fine Mesh Analysis on a Typical Transverse Web Frame, Wash Bulkhead and Web Frame adjacent to Transverse Bulkhead

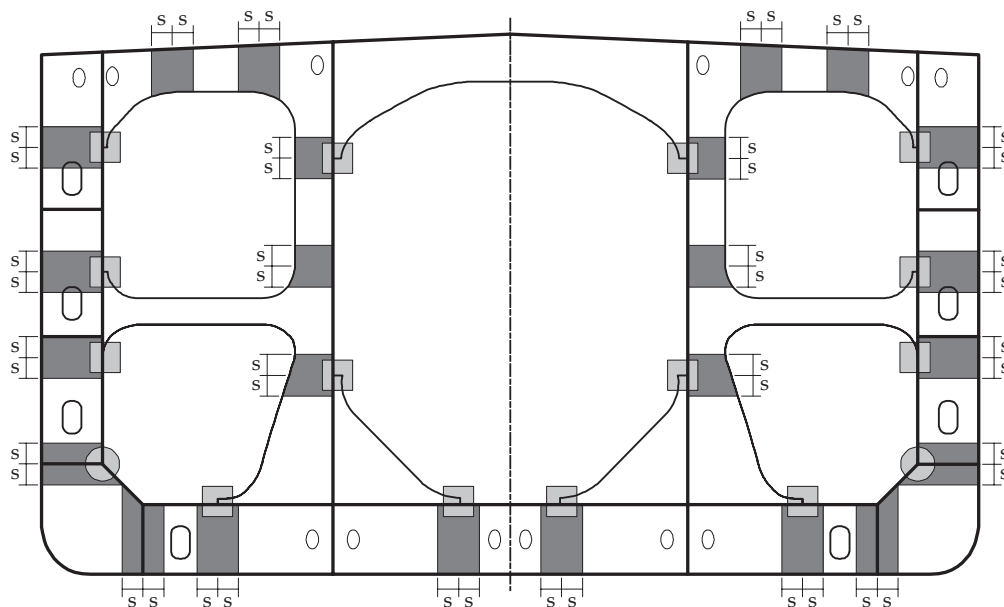

Fig. B.3.1 (Continued) Areas Requiring Consideration for Fine Mesh Analysis on a Typical Transverse Web Frame, Wash Bulkhead and Web Frame adjacent to Transverse Bulkhead

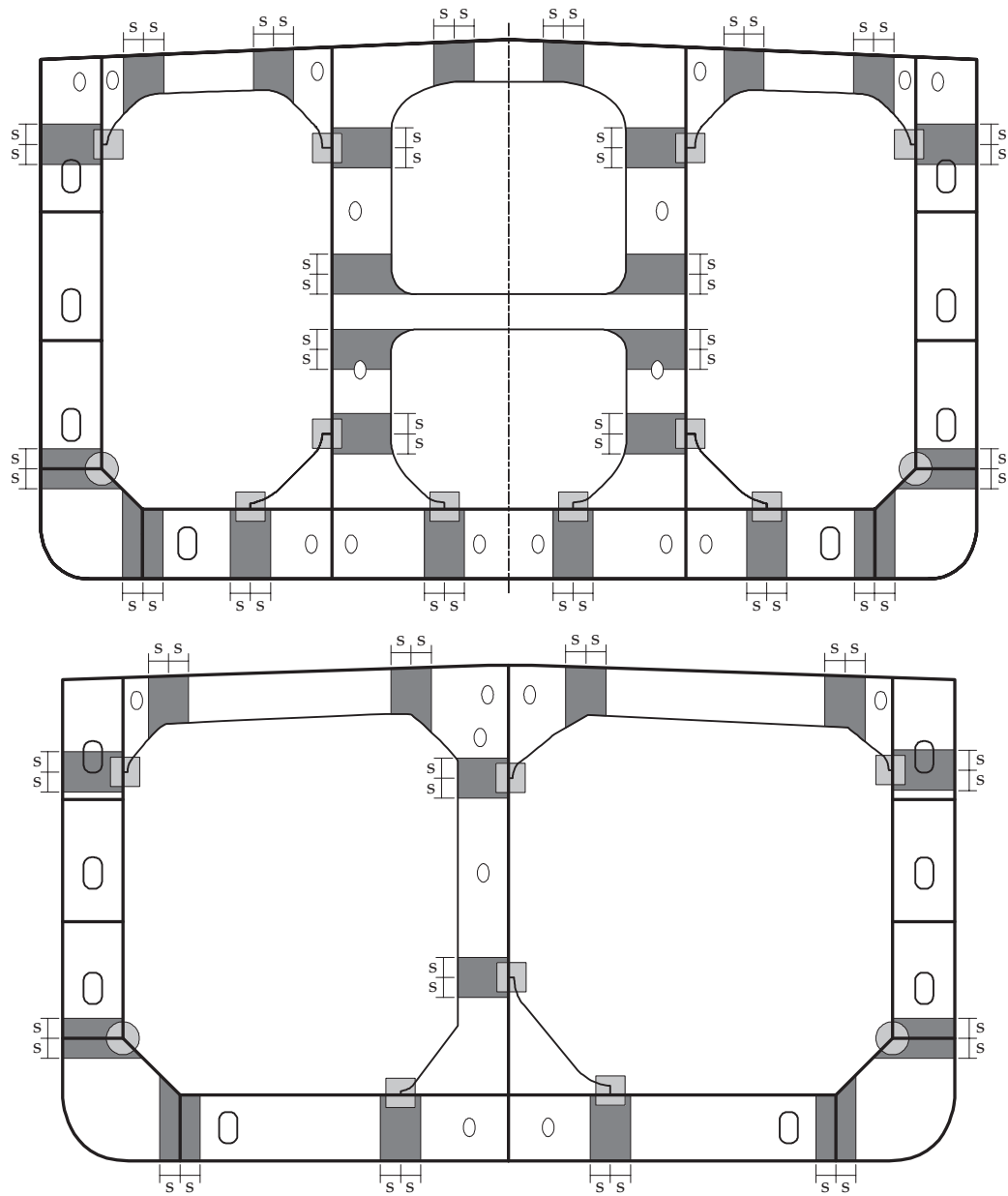

Fig. B.3.1 (Continued) Areas Requiring Consideration for Fine Mesh Analysis on a Typical Transverse Web Frame, Wash Bulkhead and Web Frame adjacent to Transverse Bulkhead

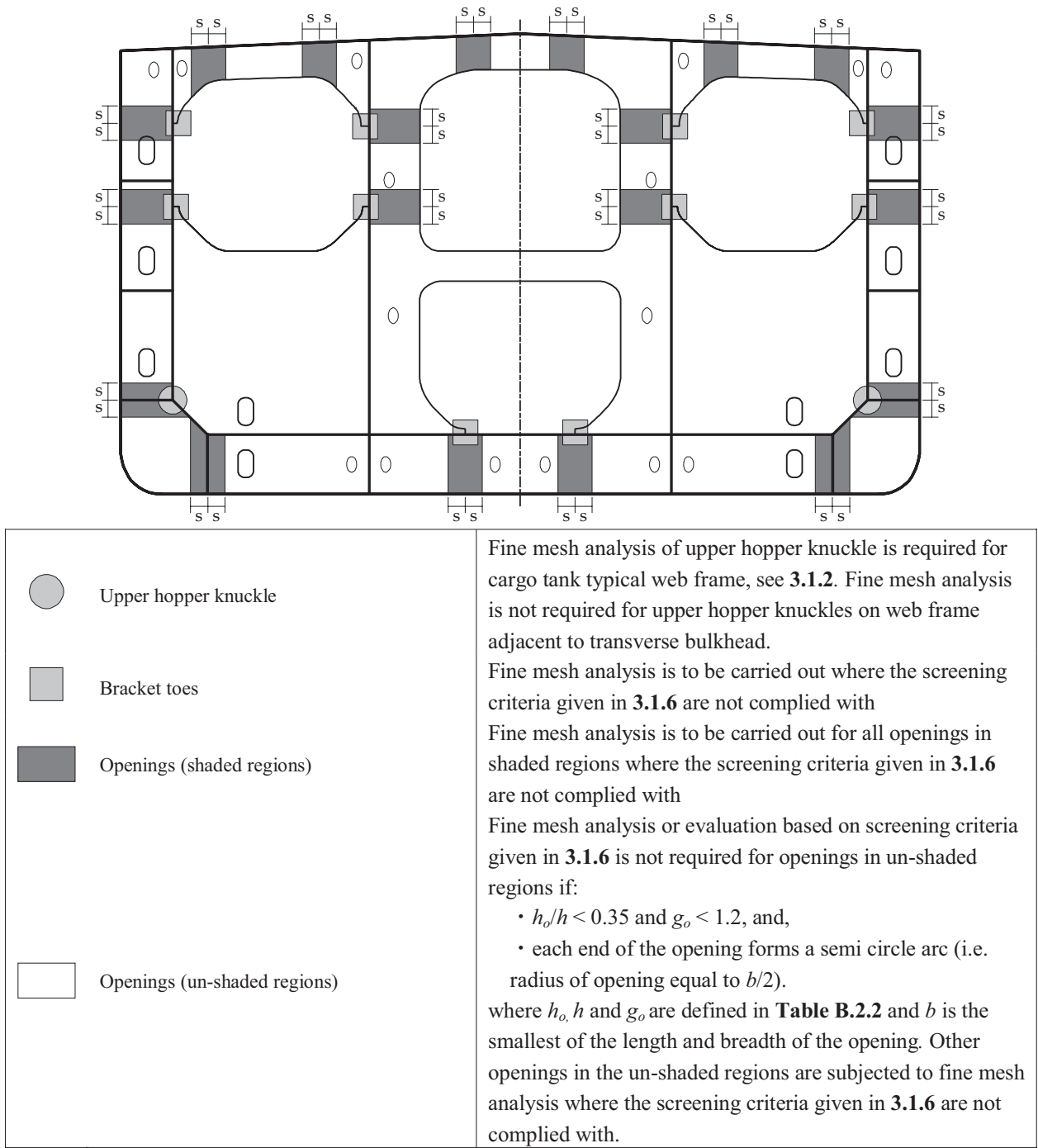
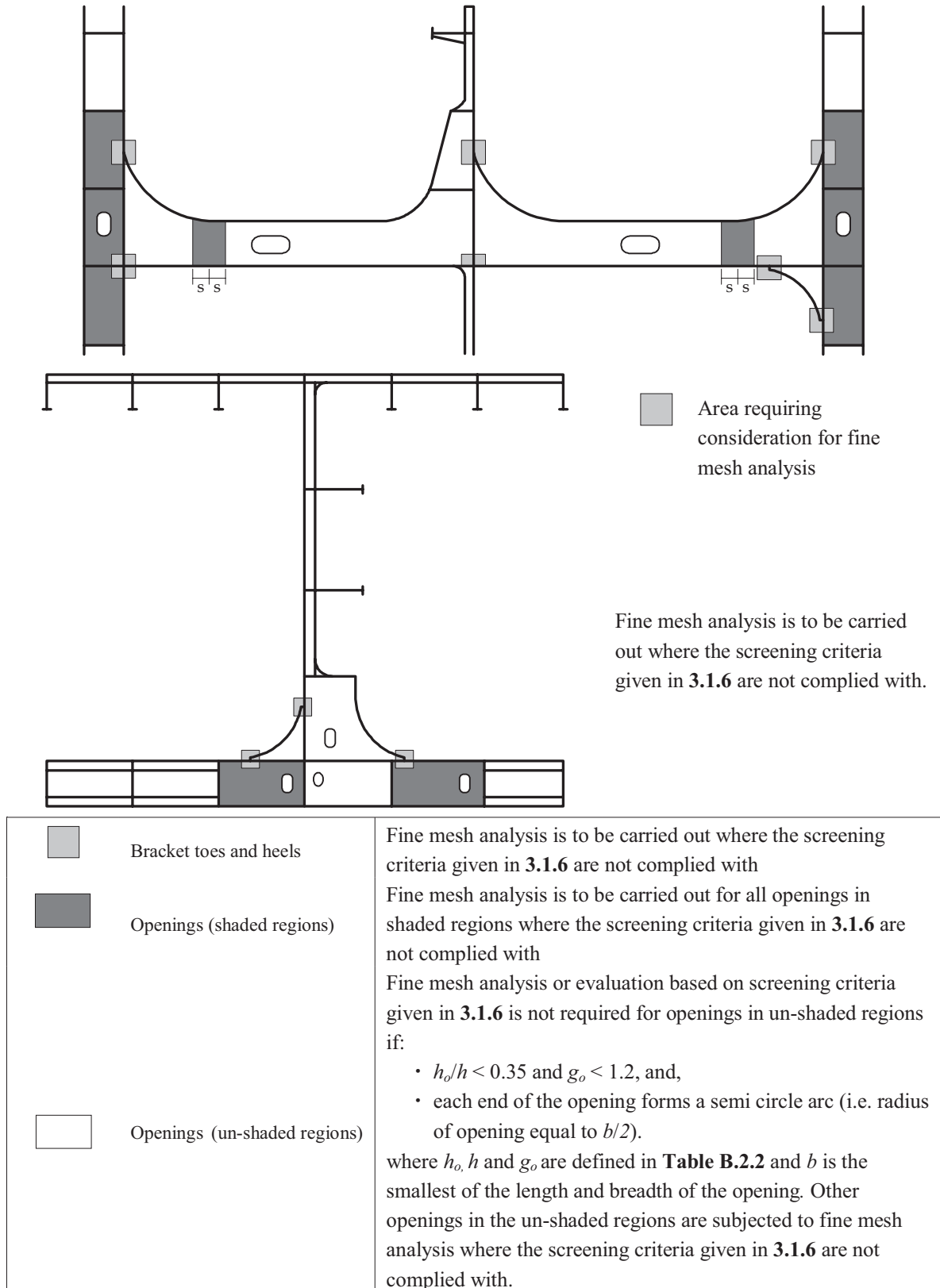

Fig. B.3.2 Areas Requiring Consideration for Fine Mesh Analysis on Horizontal Stringer and Transverse Bulkhead to Double Bottom Connections



3.1.3 Transverse bulkhead stringers, buttress and adjacent web frame

3.1.3.1 Fine mesh analysis is to be carried out for the following locations where the screening criteria given in 3.1.6 are not complied with:

- (a) main bracket toes, heels and openings on horizontal stringers of a transverse bulkhead specified in **Fig. B.3.2**. The stringers of the forward and aft transverse bulkheads of the middle tank of the FE model which indicate highest von Mises stresses in way of the structural details from the cargo tank analysis is to be selected for the fine mesh analysis.
- (b) main bracket toes and openings on transverse bulkhead to double bottom connection or buttress structure specified in **Fig. B.3.2**. The double bottom connection/buttress structure in way of the forward and aft transverse bulkheads of the middle tank of the FE model which indicates highest von Mises stresses in way of the structural details from the cargo tank analysis is to be selected for the fine mesh analysis.
- (c) main bracket toes and openings specified in **Fig. B.3.1** on a web frame adjacent to the transverse bulkhead. Both web frames in way of the horizontal stringers of the forward and aft transverse bulkheads of the middle tank of the cargo tank FE model are to be considered. The web frame which indicates highest von Mises stresses in way of the structural details from the cargo tank analysis is to be selected for the fine mesh analysis.

3.1.3.2 Where the stress level at the heel connection of the transverse bulkhead horizontal stringer to the side horizontal girder exceeds the permissible criteria, it is recommended that a backing bracket be fitted in accordance with **Appendix C/2.5** to reduce the stresses.

3.1.4 Deck, double bottom longitudinal and adjoining transverse bulkhead vertical stiffeners

3.1.4.1 End connections and attached web stiffeners of the following structural members are to be assessed:

- (a) at least one pair of inner and outer bottom longitudinal stiffeners and adjoining vertical stiffener of transverse bulkhead
- (b) at least one longitudinal stiffener on deck and adjoining vertical stiffener of transverse bulkhead

3.1.4.2 The selection of the longitudinal and vertical stiffeners to be analysed is to be based on the maximum relative deflection between supports, e.g. between floor and transverse bulkhead. Where there is a significant variation in end connection arrangement and scantlings between stiffeners, analysis of additional stiffeners may be required. **Fig. B.3.3** shows the areas that require fine mesh analysis in way of deck, inner bottom and bottom longitudinal and transverse bulkhead vertical stiffeners.

3.1.5 Corrugated bulkheads

3.1.5.1 Where no shedder plate or shedder plate without a gusset plate is fitted to a corrugated transverse or longitudinal corrugated bulkhead, connection of corrugation and below supporting structure to lower stool shelf plate, as shown in **Fig. B.3.4**, is to be evaluated by fine mesh analysis. Where no lower stool is fitted, connection of corrugation and below supporting structure to inner bottom plate is to be evaluated by fine mesh analysis.

3.1.5.2 Where shedder plate with a gusset plate is fitted to a corrugated transverse or longitudinal corrugated bulkhead, connection of the corrugation at the upper corner of the gusset plate is to be evaluated by fine mesh analysis.

3.1.5.3 The selection of the location of the corrugation unit for fine mesh analysis is to be based on the stress result from the cargo tank analysis. The location with the highest von Mises stress in way of the corrugation connection is to be selected for the analysis.

3.1.5.4 Where transverse and longitudinal corrugated bulkheads are of different arrangements or scantlings, the fine mesh analysis is to be carried out for both bulkheads.

3.1.5.5 Where the stress level at the connection of corrugation to the lower stool exceeds the permissible criteria, it is recommended that shedder plate and gusset plate be fitted in accordance with **Appendix C/2.5** to reduce the stresses. See **Section 8/2.5.7.9** for required arrangement of supporting structure for corrugated bulkhead without a lower stool.

Fig. B.3.3 Areas Requiring Fine Mesh Analysis on Deck, Inner and Outer Bottom Longitudinals

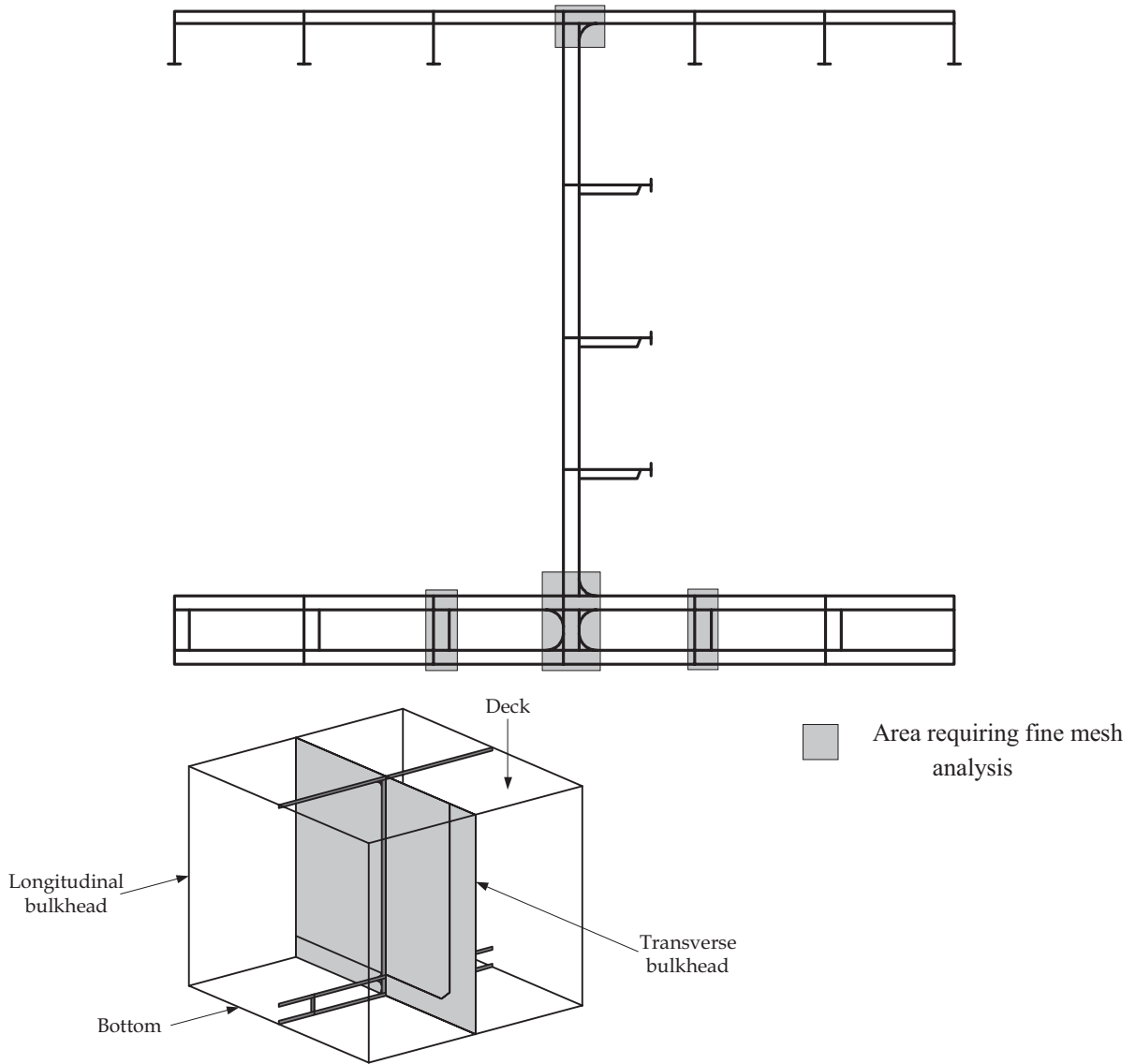
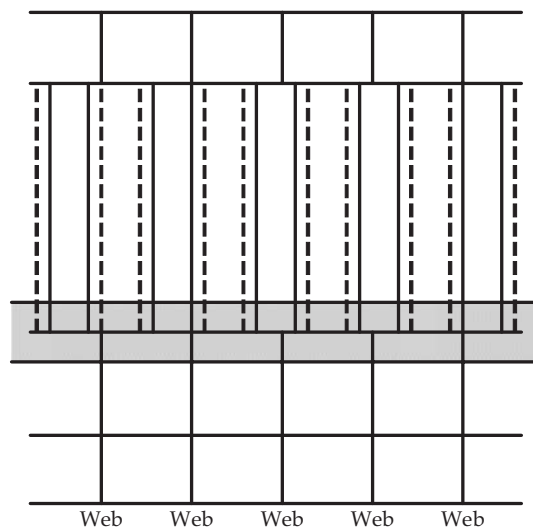

Fig. B.3.4 Areas Requiring Fine Mesh Analysis at Connections of Corrugated Bulkhead to Bottom Stool



Note:

Exact location of corrugation unit to be examined using fine mesh analysis is to be selected based on stress result from cargo tank analysis.

3.1.6 Screening criteria for Fine Mesh Analysis

3.1.6.1 The criteria given in this section are intended to identify areas that require to be investigated by means of fine mesh finite element analysis. These criteria apply to openings, bracket toes and heels of transverse web frames, vertical and transverse webs of wash bulkheads, horizontal stringers of transverse bulkhead and adjoining side horizontal girders, buttress and bottom girders.

3.1.6.2 Where the criteria given in this section for the structural detail are complied with, fine mesh finite element analysis of the structural detail may be waived with the exception of 3.1.6.3. The compliance with these criteria is to be verified for all finite element load cases.

3.1.6.3 Large openings, for which their geometry is required to be represented in the cargo tank FE model in accordance with **Table B.2.2**, are to be investigated by fine mesh analysis.

Table B.3.1 Fine Mesh Analysis Screening Criteria for Openings in Primary Support Members

A fine mesh finite element analysis is to be carried out where:	
$\lambda_y > 1.7$	(load combination S + D)
$\lambda_y > 1.36$	(load combination S)
Where:	
λ_y	: yield utilisation factor
	$= 0.85C_h \left[\sigma_x + \sigma_y + \left(2 + \left(\frac{l_o}{2r} \right)^{0.74} + \left(\frac{h_o}{2r} \right)^{0.74} \right) \tau_{xy} \right] \frac{k}{235}$
C_h	$= 1.0 - 0.23 \left(\frac{h_o}{h} \right) + 2.12 \left(\frac{h_o}{h} \right)^2$ for openings in vertical web and horizontal girder of wing ballast tank, double bottom floor and girder and horizontal stringer of transverse bulkhead
	$= 1.0$ for opening in web of main bracket and buttress (see figures below)
r	: radius of opening, in <i>mm</i>
h_o	: height of opening parallel to depth of web, in <i>mm</i>
l_o	: length of opening parallel to girder web direction, in <i>mm</i>
h	: height of web of girder in way of opening, in <i>mm</i>
σ_x	: axial stress in element x direction determined from cargo tank FE analysis according to the coordinate system shown, in N/mm^2
σ_y	: axial stress in element y direction determined from cargo tank FE analysis according to the coordinate system shown, in N/mm^2
τ_{xy}	: element shear stress determined from cargo tank FE analysis, in N/mm^2 , ⁽²⁾
k	: higher strength steel factor, as defined in Section 6/1.1.4 but not to be taken as less than 0.78 for load combination S + D

Table B.3.1 (Continued) Fine Mesh Analysis Screening Criteria for Openings in Primary Support Members

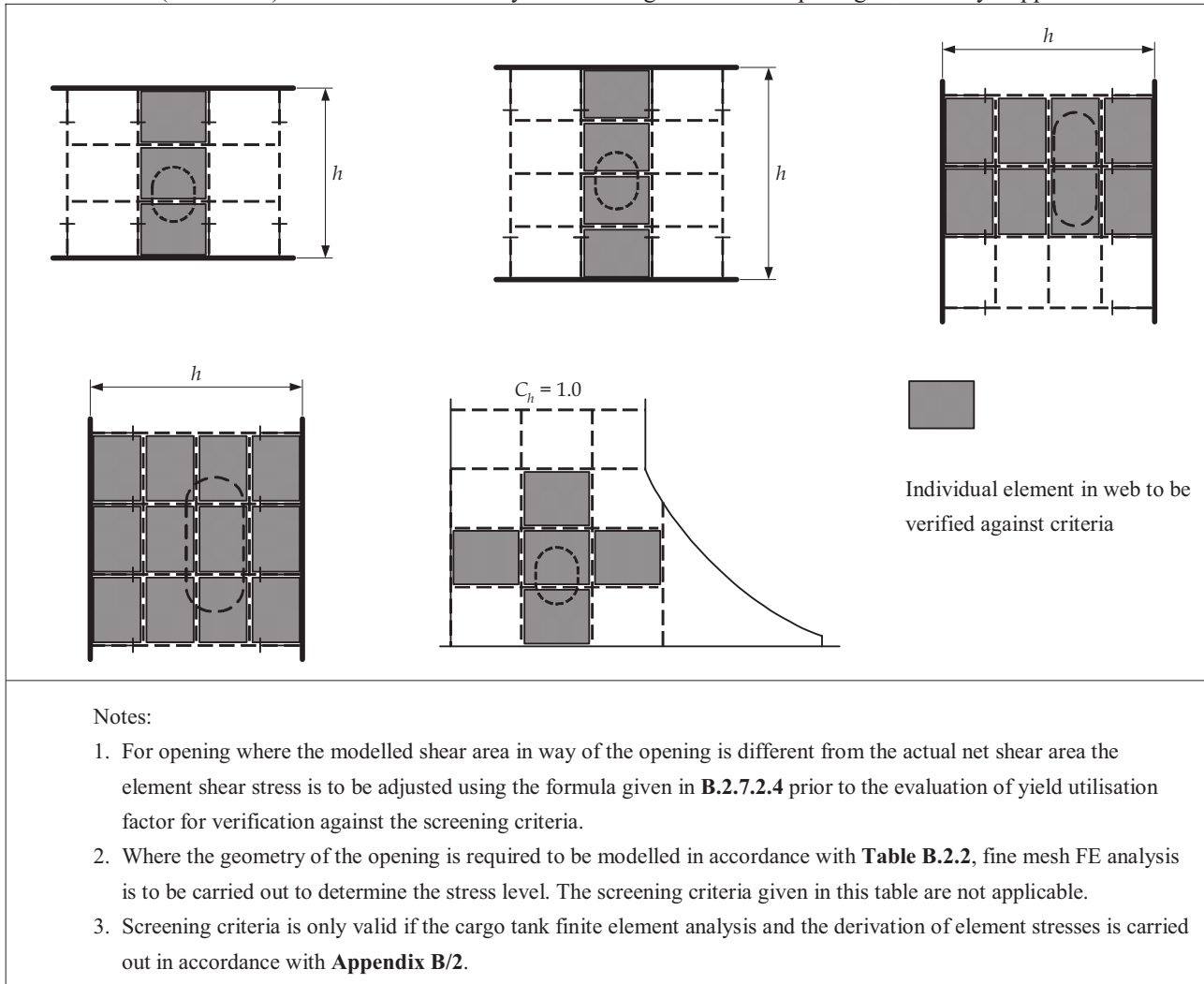

Table B.3.2 Fine Mesh Analysis Screening Criteria for Bracket Toes of Primary Support Members

A fine mesh finite element analysis is to be carried out where: $\lambda_y > 1.5$ (load combination S + D) $\lambda_y > 1.2$ (load combination S)	
Where:	
λ_y	: yield utilisation factor $= C_a \left(0.75 \left(\frac{b_2}{b_1} \right)^{0.5} \sigma_{vm} + 0.55 \left(\frac{A_{bar-net50}}{b_1 t_{net50}} \right)^{0.5} \sigma_{bar} \right) \frac{k}{235}$
C_a	$= 1.0 - 0.2 \left(\frac{R_a}{1400} \right)^2$
b_1, b_2	: height of plate element in way of bracket toe in cargo tank FE model, in <i>mm</i>
$A_{bar-net50}$: sectional area of bar element in cargo tank FE model representing the face plate of bracket, in <i>mm</i> ²
σ_{bar}	: bar element axial stress determined from cargo tank FE analysis, in <i>N/mm</i> ²
σ_{vm}	: von Mises stress of plate element in way of bracket toe determined from cargo tank FE analysis, in <i>N/mm</i> ²
t_{net50}	: thickness of plate element in way of bracket toe, in <i>mm</i>
R_a	: leg length distance in <i>mm</i> , not to be taken as greater than 1400 <i>mm</i>
k	: higher strength steel factor, as defined in Section 6/1.1.4 , but not to be taken as less than 0.78 for load combination S + D
Note: 1. Screening criteria is only valid if the cargo tank finite element analysis and the derivation of element stresses is carried out in accordance with Appendix B/2 .	

Table B.3.3 Fine Mesh Analysis Screening Criteria for Heels of Transverse Bulkhead Horizontal Stringers

<p>A fine mesh finite element analysis is to be carried out where:</p> <p>$\lambda_y > 1.5$ (load combination S + D)</p> <p>$\lambda_y > 1.2$ (load combination S)</p>	
<p>Where:</p> <p>λ_y : yield utilisation factor</p> $= 3.0 \left \sigma_{vm} \right \frac{k}{235}$ <p>for heels at side horizontal girder and transverse bulkhead horizontal stringer, i.e. locations 1, 2 and 3 in figures.</p> $= 5.2 \left \sigma_x \right \frac{k}{235}$ <p>for heel at longitudinal bulkhead horizontal stringer, i.e. location 4.</p> <p>σ_x : axial stress in element x direction determined from cargo tank FE analysis in accordance with the coordinate system shown, in N/mm^2</p> <p>σ_{vm} : von Mises stress of plate element in way of heel determined from cargo tank FE analysis, in N/mm^2</p> <p>k : higher strength steel factor, as defined in Section 6/1.1.4, but not to be taken as less than 0.78 for load combination S + D</p>	
<p>Note:</p> <p>1. Screening criteria is only valid if the cargo tank finite element analysis and the derivation of element stresses is carried out in accordance with Appendix B/2.</p>	

3.2 Structural Modelling

3.2.1 General

3.2.1.1 Evaluation of detailed stresses requires the use of refined finite element mesh in way of areas of high stress. This fine mesh analysis can be carried out by means of separate local finite element model with fine mesh zones in conjunction with the boundary conditions obtained from the cargo tank model. Alternatively, fine mesh zones incorporated into the cargo tank model may be used.

3.2.1.2 The extent of the local finite element model is to be such that the calculated stresses at the areas of interest are not significantly affected by the imposed boundary conditions and application of loads. The boundary of the fine mesh model is to coincide with primary support members, such as girders, stringers and floors, in the cargo tank model.

3.2.1.3 The mesh size in the fine mesh zones is not to be greater than $50\text{mm} \times 50\text{mm}$. In general, the extent of the fine mesh zone is not to be less than 10 elements in all directions from the area under investigation.

3.2.1.4 All plating within the fine mesh zone is to be represented by shell elements. A smooth transition of mesh density is to be maintained. The aspect ratio of elements within the fine mesh zone is to be kept as close to 1 as possible. Variation of mesh density within the fine mesh zone and the use of triangular elements are to be avoided. In all cases, the elements are to have an aspect ratio not exceeding 3. Distorted elements, with element corner angle less than 60° or greater than 120° , are to be avoided. Stiffeners inside the fine mesh zone are to be modelled using shell elements. Stiffeners outside the fine mesh zones may be modelled using beam elements.

3.2.1.5 The element inside the fine mesh zone is to be modelled based on the net thickness, obtained by deducting the full corrosion addition, t_{corr} , from the gross thickness. The structure outside the fine mesh zone is to be modelled based on the net thickness obtained by deducting half the corrosion addition, $0.5t_{corr}$, from the gross thickness, as specified in **2.2.1.5**, for use in the cargo tank FE analysis.

3.2.1.6 Where fine mesh analysis is required for main bracket end connections, the fine mesh zone is to be extended at least 10 elements in all directions from the area of interest, see **Fig. B.3.5**. The modelling scantlings in the fine mesh zone are to be in accordance with **3.2.1.5**.

3.2.1.7 Where fine mesh analysis is required for an opening, the first two layers of elements around the opening are to be modelled with mesh size not greater than $50\text{mm} \times 50\text{mm}$, based on the net thickness with deduction of full corrosion addition, t_{corr} . The elements outside the first two layers are to be based on the net thickness with a deduction of corrosion addition, $0.5t_{corr}$, see **3.2.1.5**. A smooth transition from the fine mesh to the coarser mesh is to be maintained. Edge stiffeners which are welded directly to the edge of an opening are to be modelled with plate elements. Web stiffeners close to an opening may be modelled using rod or beam elements located at a distance of at least 50mm from the edge of the opening. Typical fine mesh zone around an opening is shown in **Fig. B.3.6**.

3.2.1.8 Face plates of openings, primary support members and associated brackets are to be modelled with at least three elements across their width.

Fig. B.3.5 Fine Mesh Zone Around Bracket Toes

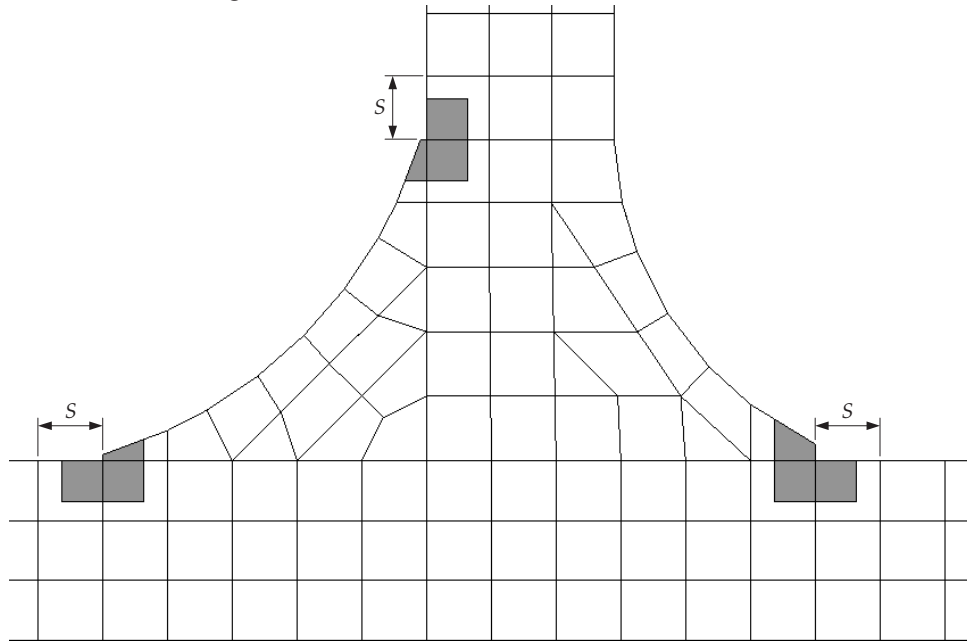

-  Fine mesh zone
- Element size $\leq 50mm \times 50mm$
- Extent - at least 10 elements in all directions
- Face plate modelled by plate elements

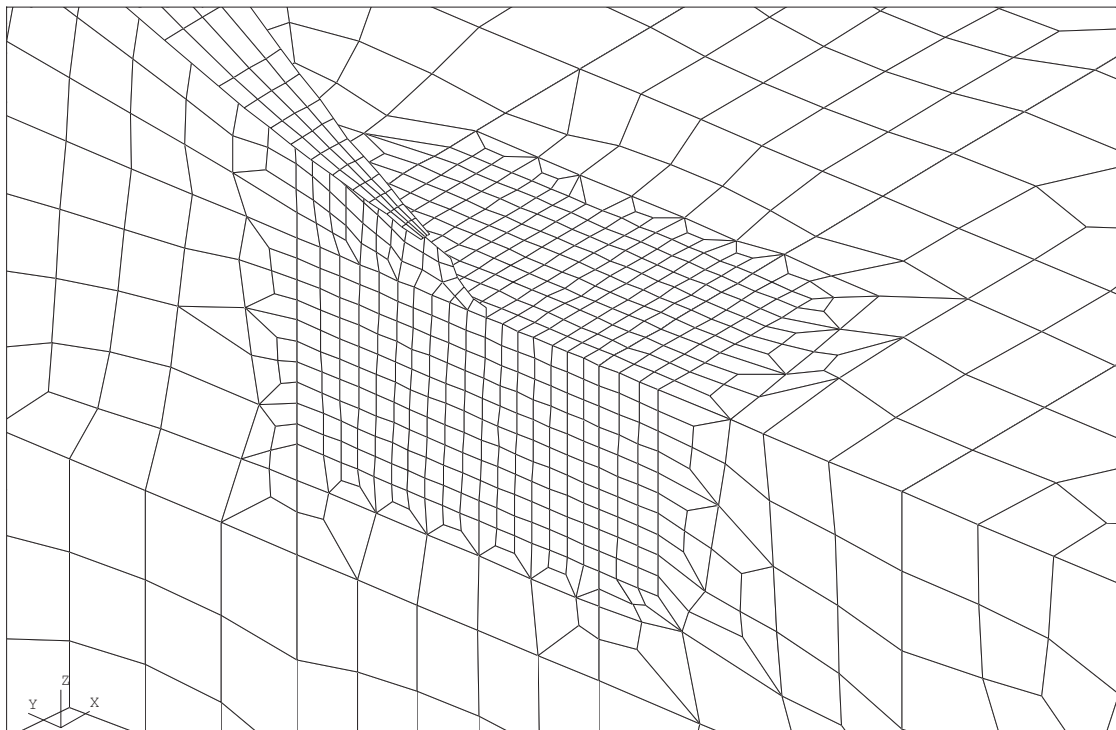
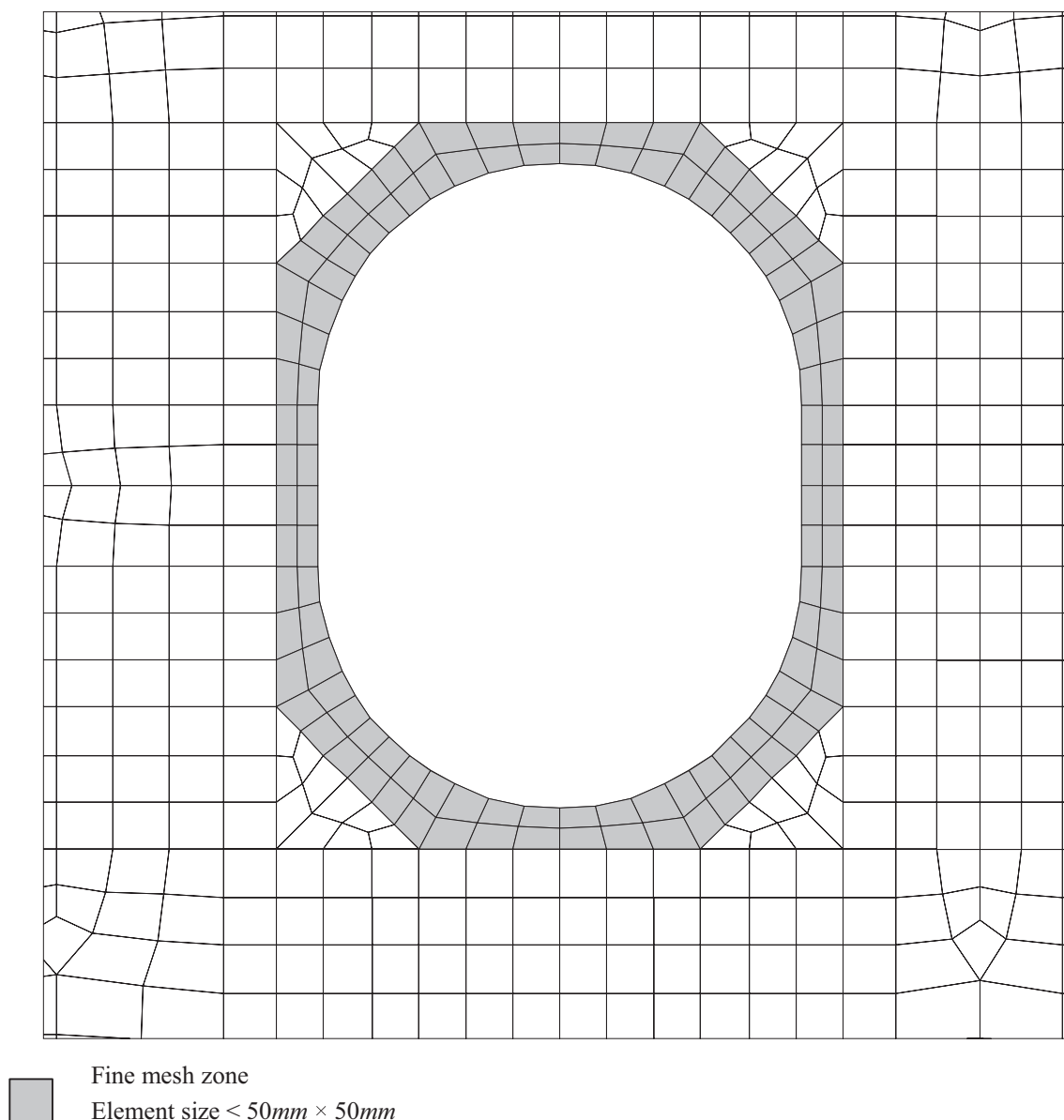

Fig. B.3.6 Fine Mesh Zone Around an Opening



3.2.2 Transverse web frames

3.2.2.1 In addition to the requirements of 3.2.1, the modelling requirements in this sub-section are applicable to the analysis of typical transverse web frame.

3.2.2.2 Where a FE sub model is used, the model is to have an extent of at least 1 + 1 web frame spaces, i.e. one web frame space extending either side of the transverse web frame under investigation. The transverse web frames forward and aft of the web frame under investigation need not be included in the sub model.

3.2.2.3 The full depth and full breadth of the ship shall be modelled, see **Fig. B.3.7**.

3.2.2.4 **Fig. B.3.8** shows a close up view of the finite element mesh at the lower part of the vertical web and backing brackets.

Fig. B.3.7 Extent of Sub-Model for Fine Mesh Analysis of Web Frame Bracket Connections and Openings

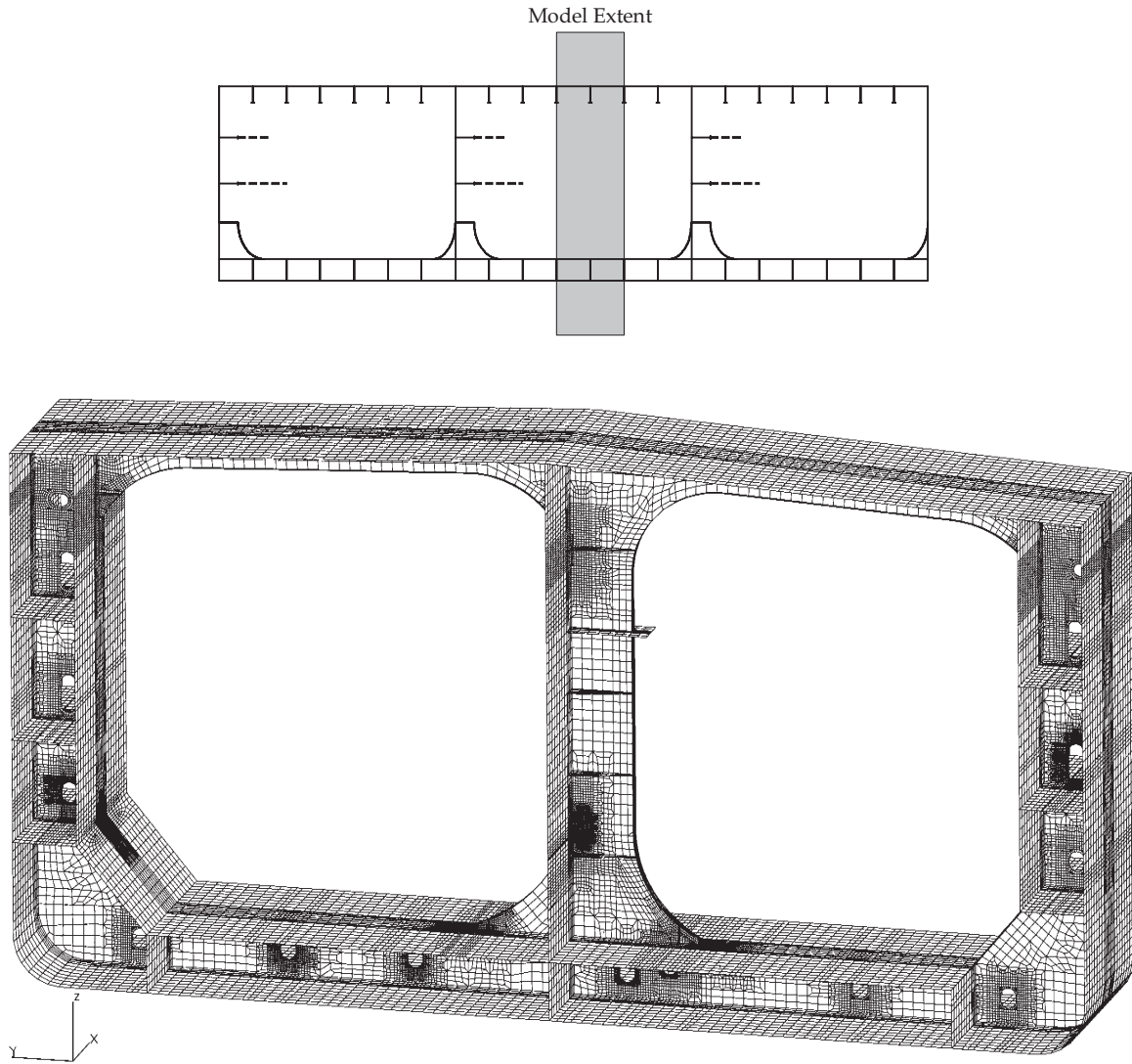
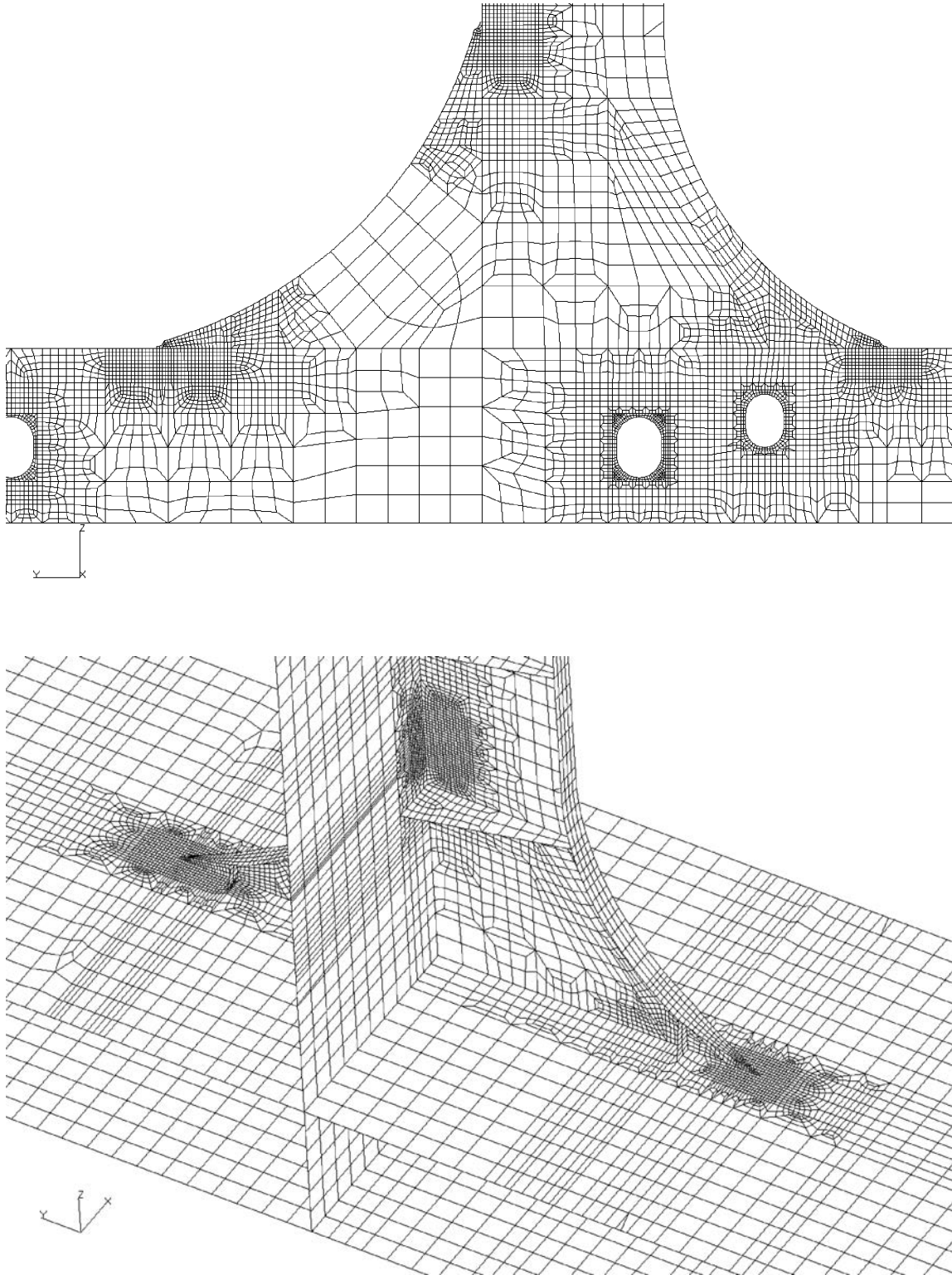

Fig. B.3.8 Close-up View of Finite Element Mesh at the Lower Part of a Vertical Web Frame and Backing Brackets



3.2.3 Transverse bulkhead stringers, buttress and adjacent web frame

3.2.3.1 In addition to 3.2.1, the modelling requirements in this sub-section are applicable to the analysis of transverse bulkhead and adjacent web frame as described in 3.1.3.

3.2.3.2 Due to the structural interaction between the transverse bulkhead, horizontal stringers, web frames, deck and bottom, it is recommended that the FE sub-model represents a full section of the hull. Longitudinally, the ends of the

model should at least be extended one web frame space beyond the areas that require investigation, see **Fig. B.3.9**. The full breadth and depth of the ship should be modelled.

3.2.3.3 Alternatively, it is acceptable to use a number of sub-models, as shown in **Fig. B.3.10**, to analyse different parts of the structure. For the analysis of the transverse bulkhead horizontal stringers the full breadth of the ship should be modelled. For the analysis of buttress structure, the sub-model width should be at least 4 + 4 longitudinal spaces, i.e. four longitudinal spaces at each side of the buttress.

3.2.3.4 **Fig. B.3.11** shows the finite element mesh on a transverse bulkhead horizontal stringer. **Fig. B.3.12** shows the sub-model for the analysis of buttress connections to transverse bulkhead and double bottom structure, and openings.

Fig. B.3.9 Extent of Sub-Model for Fine Mesh Analysis of Transverse Bulkhead and Adjacent Structure

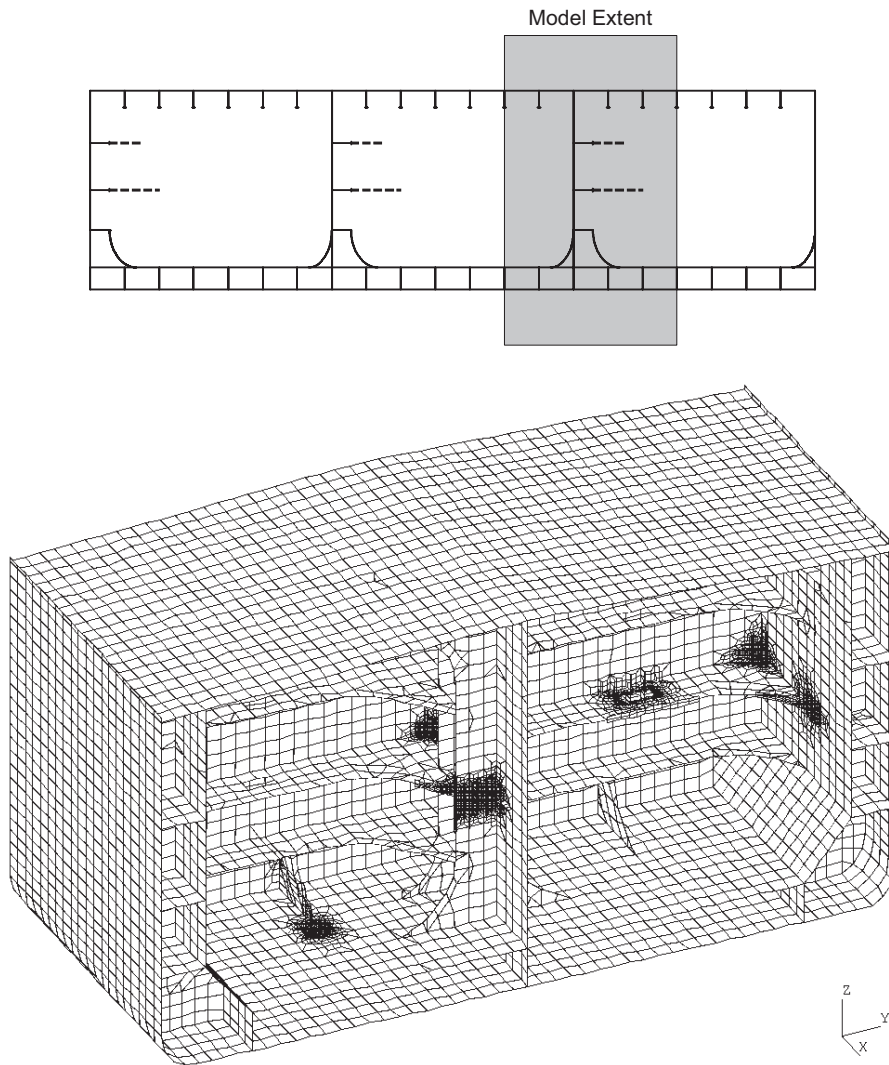

Fig. B.3.10 Analysis of Transverse Bulkhead Structure Using Sub-Models

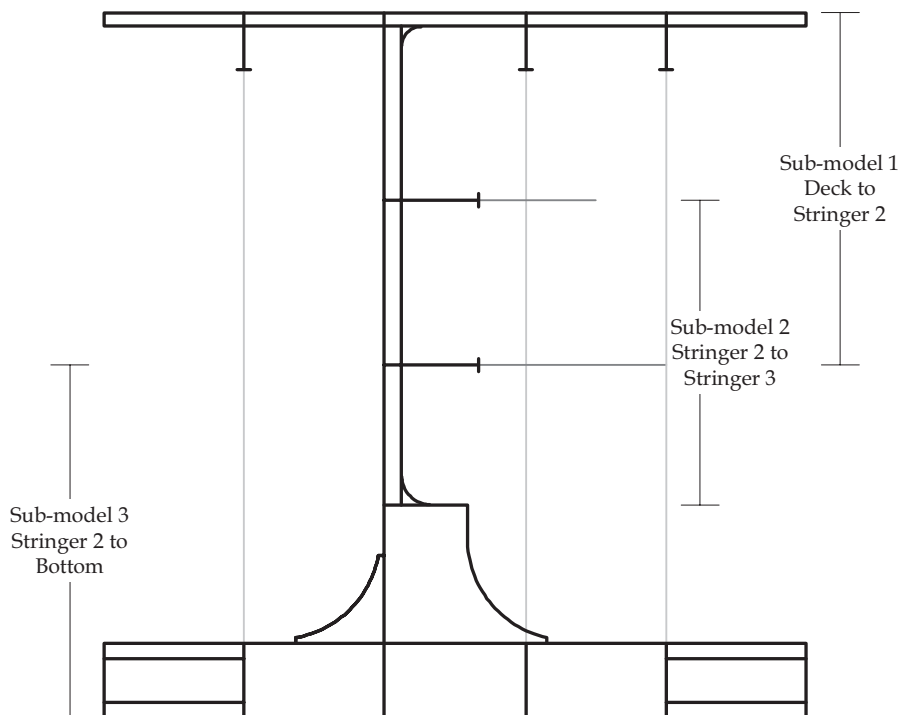

Fig. B.3.11 Finite Element Mesh on Transverse Bulkhead Horizontal Stringer (figure shows port side of model)

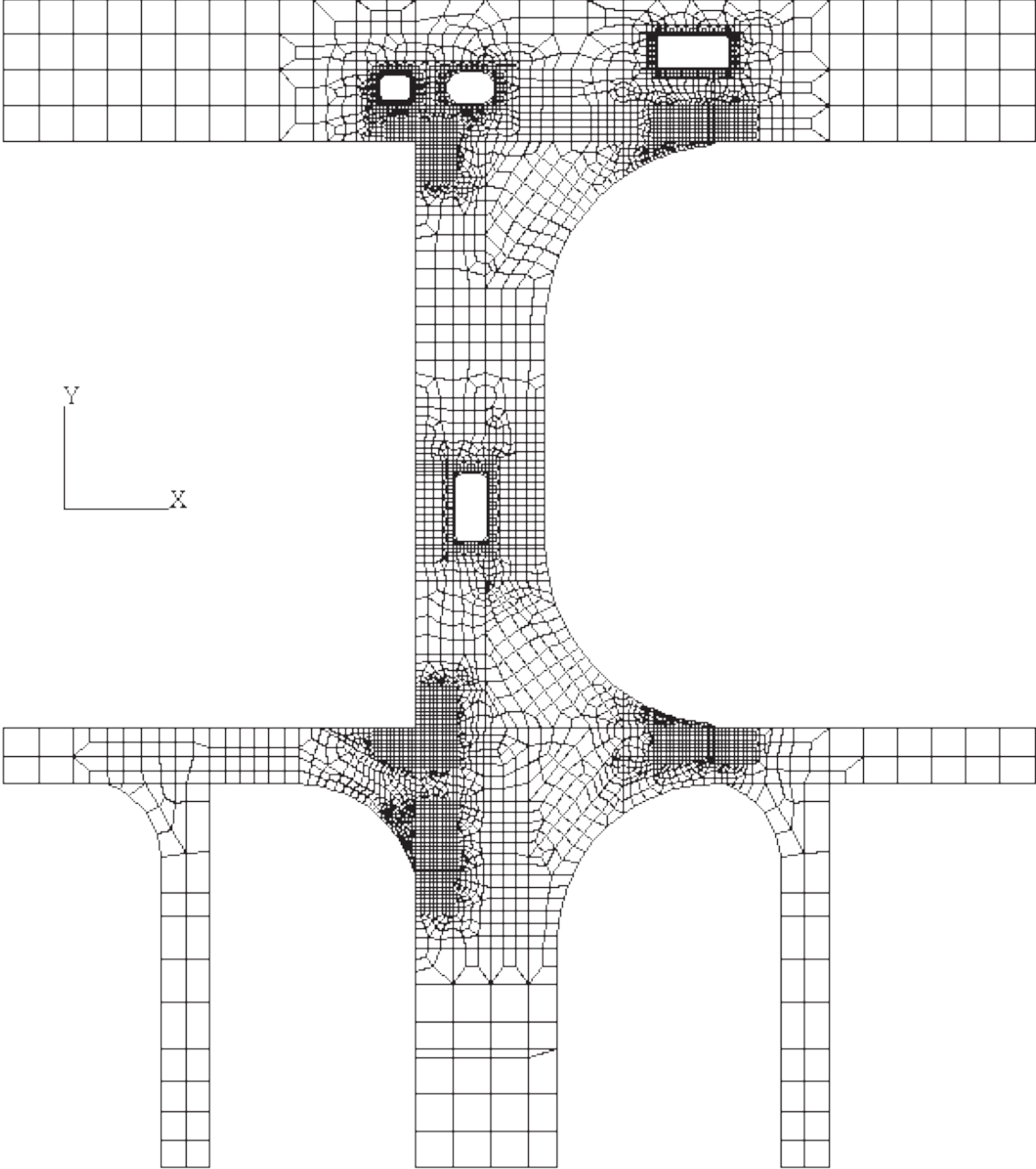
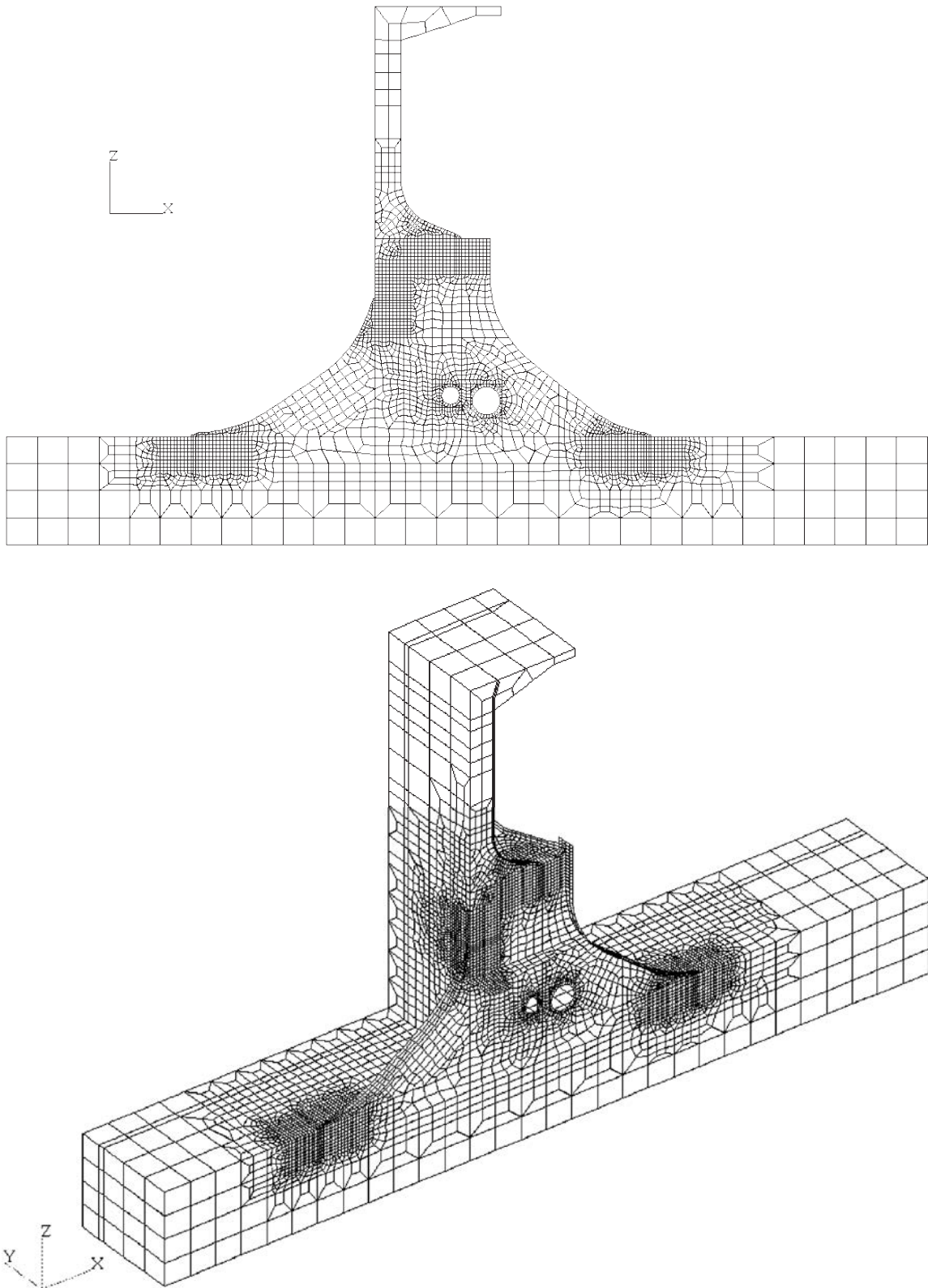

Fig. B.3.12 Sub-Model for the Analysis of Buttress Connections to Bulkhead and Double Bottom Structure (figure shows port half of model)



3.2.4 Deck, double bottom longitudinal and adjoining transverse bulkhead vertical stiffeners

3.2.4.1 The modelling requirements in this sub-section are applicable specifically to the analysis of longitudinal and vertical stiffener end connections and attached web stiffeners as described in 3.1.4.

3.2.4.2 Where a local FE model is used, each end of the model is to be extended longitudinally at least two web frame spaces from the areas under investigation. The model width is to be at least $2 + 2$ longitudinal spaces.

Fig. B.3.13 shows the longitudinal extent of the sub-model for the analysis of deck and double bottom longitudinal stiffeners and adjoining transverse bulkhead vertical stiffener.

3.2.4.3 The prescribed displacements or forces obtained from the cargo tank FE model should be applied to all boundary nodes which coincide with the cargo tank model.

3.2.4.4 The longitudinal and vertical stiffeners under investigation, including web, faceplate, attached plating (within $\frac{1}{2} + \frac{1}{2}$ longitudinal spaces) and associated brackets are to be modelled based on the gross thickness with deduction of the full corrosion addition t_{corr} . Other areas are to be based on gross thickness with deduction of half corrosion addition, $0.5t_{corr}$.

3.2.4.5 The web of the longitudinal stiffeners should be represented by at least 3 shell elements across its depth. Similar size elements should be used to represent the plating of the bottom shell and inner bottom. The face plate of the longitudinal stiffeners and brackets should be modelled with at least three elements across its width.

3.2.4.6 The mesh size and extent of the fine mesh zone is to be in accordance with 3.2.1.3, see also **Fig. B.3.13**.

Fig. B.3.13 Sub-Model for Fine Mesh Analysis of End Connections and Web Stiffeners of Deck and Double Bottom Longitudinals

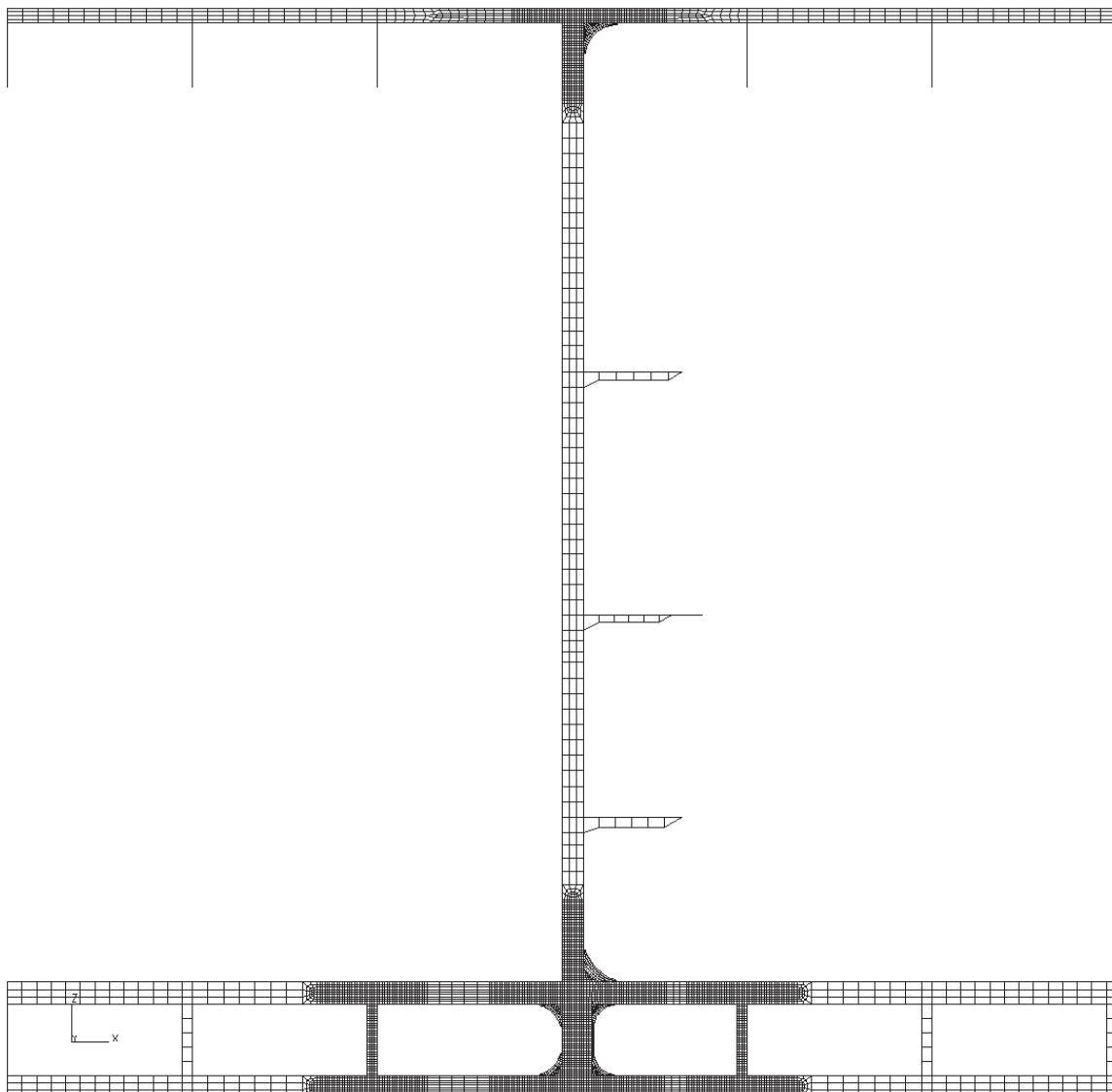
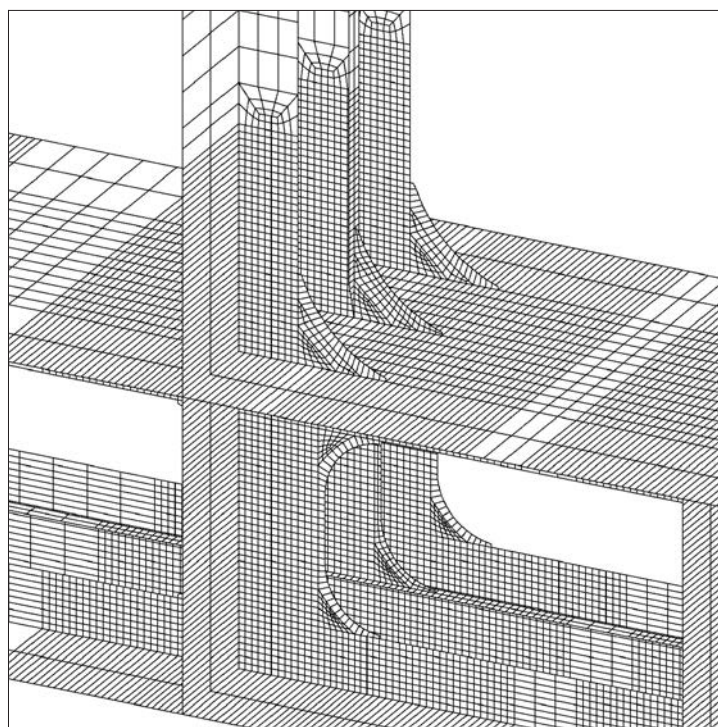
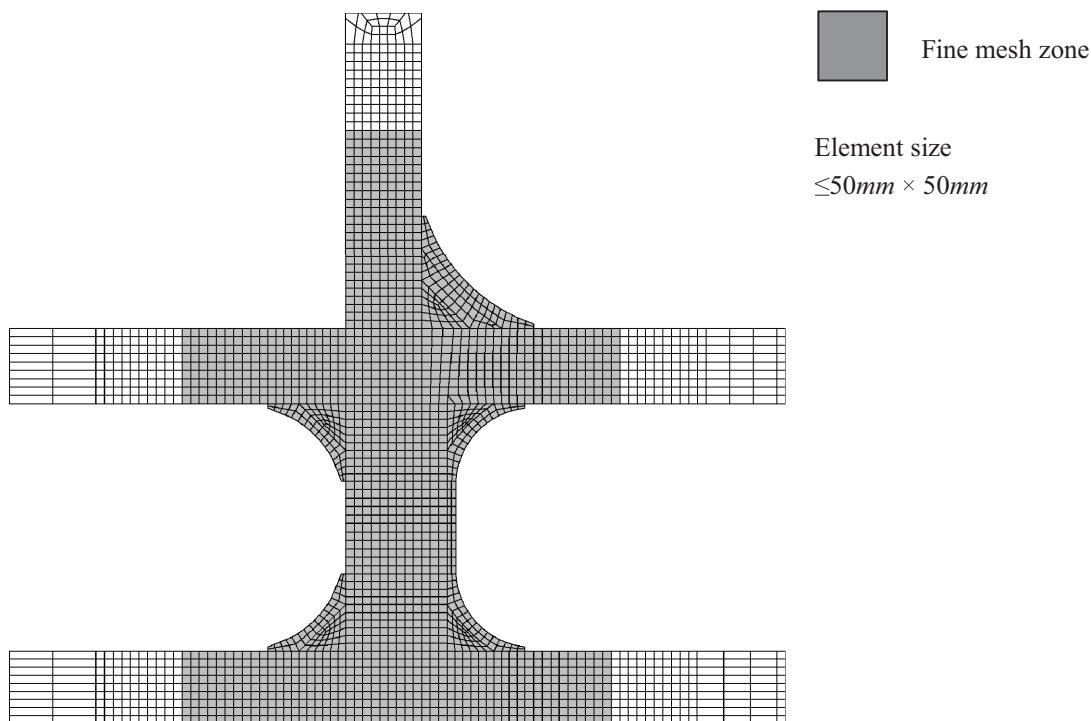

Fig. B.3.13 (Continued)

Sub-Model for Fine Mesh Analysis of End Connections and Web Stiffeners of Deck and Double Bottom Longitudinals

**3.2.5 Corrugated bulkheads**

3.2.5.1 In addition to 3.2.1, the modelling requirements in this sub-section are applicable to the analysis of connections of corrugated bulkheads to lower bulkhead stools as described in 3.1.5.

3.2.5.2 The minimum extent of the sub-model is as follows, see also Fig. B.3.14:

- (a) vertically, from the bottom of the bottom bulkhead stool to a level at least 2m above the connection of the corrugation to the upper part of the bulkhead stool. The upper boundary of the sub-model should be coincident with the horizontal mesh line of the cargo tank FE model

- (b) for transverse corrugated bulkheads, the sub-model is to be extended transversely to the nearest diaphragm web in the lower stool on each side of the fine mesh zone (i.e. the sub-model covers two bulkhead stool transverse web spaces). The end diaphragms need not be modelled
- (c) for longitudinal corrugated bulkheads, the sub-model is to be extended to the nearest web frame on each side of the fine mesh zone (i.e. the sub-model covers two frame spaces). The end web frames need not be modelled
- (d) where the area under investigation is located close to the intersection of transverse and longitudinal corrugated bulkheads, the sub-model should cover the structure between the diaphragms (in transverse direction) and web frames (in longitudinal direction) closest to the detail, whichever relevant. In addition the sub-model is to be extended at least one diaphragm/web frame outside the intersection of the stools.

3.2.5.3 The fine mesh zone is to be extended at least 500mm (10 elements) from the corrugation connection in a vertical direction, see **Fig. B.3.1.4**. In a horizontal direction, the fine mesh zone is to cover at least the corrugation flange under investigation, the adjacent corrugation webs and a further extension of 500mm from each end of the corrugation web (i.e. the fine mesh zone covers four corrugation knuckles), see **Fig. B.3.14**. The mesh size within the fine mesh zone is not to be greater than 50mm × 50mm.

3.2.5.4 Diaphragm webs, brackets inside the lower stool and vertical stiffeners on the stool side plate are to be modelled at their actual positions within the extent of the sub-model. Shell elements are to be used for modelling of diaphragm, bracket and stiffener webs. Beam elements may be used to represent the flange of stiffeners and brackets.

3.2.5.5 Horizontal stiffeners on the lower stool side plate are to be represented by beam elements.

3.2.5.6 **Fig. B.3.15** shows the finite element sub-model for the fine mesh analysis of longitudinal bulkhead to lower stool connection.

Fig. B.3.14 Extent of Sub-Model and Fine Mesh Zone for the Analysis of Corrugated Bulkhead Connection to Lower Stool

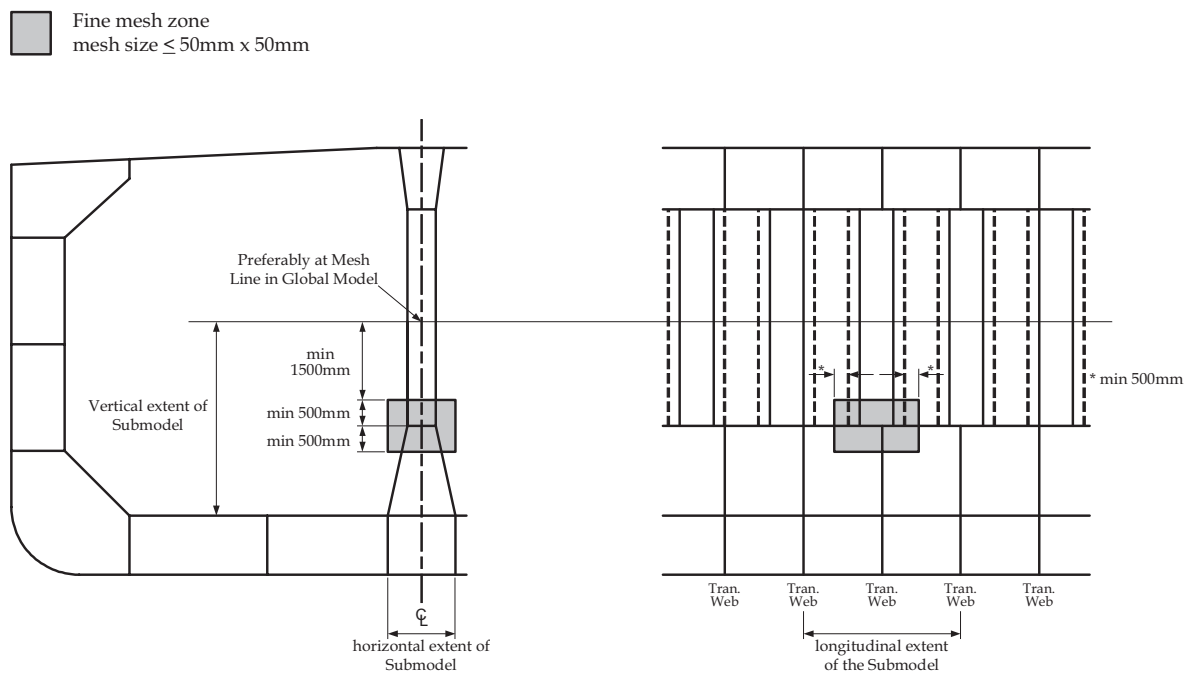

Note:

Above figures show extent of sub-model and fine mesh zone on longitudinal corrugated bulkhead connection to lower stool. Similar extent applies to transverse corrugated bulkhead.

Fig. B.3.15 Sub-Model for the Analysis of Connection of Longitudinal Corrugated Bulkhead to Lower Stool

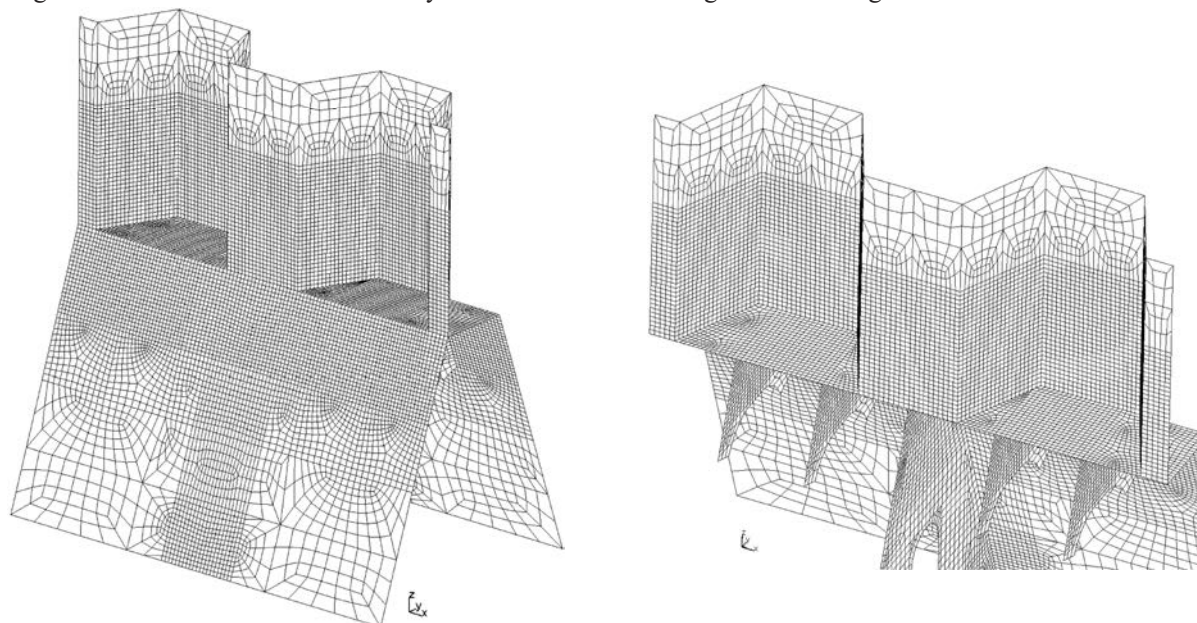

3.3. Loading Conditions

3.3.1 Stress analysis

3.3.1.1 The fine mesh detailed stress analysis is to be carried out for the standard load cases specified in 2.3.1, and any other load cases specially considered as required by Section 9/2.2.3.

3.4 Application of Loads and Boundary Conditions

3.4.1 General

3.4.1.1 Where a separate local finite element model is used for the fine mesh detailed stress analysis, the nodal displacements from the cargo tank model are to be applied to the corresponding boundary nodes on the local model as prescribed displacements. Alternatively, equivalent nodal forces from the cargo tank model may be applied to the boundary nodes.

3.4.1.2 Where there are nodes on the local model boundaries which are not coincident with the nodal points on the cargo tank model, it is acceptable to impose prescribed displacements on these nodes using multi-point constraints. The use of linear multi-point constraint equations connecting two neighbouring coincident nodes is considered sufficient.

3.4.1.3 All local loads, including any vertical loads applied for hull girder shear force correction, in way of the structure represented by the separate local finite element model are to be applied to the model.

3.5 Result Evaluation and Acceptance Criteria

3.5.1 Stress assessment

3.5.1.1 Stress assessment of the fine mesh analysis is to be carried out for the load cases specified in 3.3.1.

3.5.1.2 The von Mises stress, σ_{vm} , is to be calculated based on the membrane direct axial and shear stresses of the plate element evaluated at the element centroid. Where shell elements are used, the stresses are to be evaluated at the mid plane of the element.

3.5.1.3 The resulting von Mises stresses are not to exceed the permissible membrane values specified in Section 9/2.3.5.

3.5.1.4 The maximum permissible stresses are based on the mesh size of $50\text{mm} \times 50\text{mm}$ as specified in 3.2.1. Where a smaller mesh size is used, an average von Mises stress calculated over an area equal to the specified mesh size may be used to compare with the permissible stresses. The averaging is to be based only on elements with their entire boundary located within the desired area. The average stress is to be calculated based on stresses at element

centroid; stress values obtained by interpolation and/or extrapolation are not to be used. Stress averaging is not to be carried across structural discontinuities and abutting structure.

4. Evaluation of Hot Spot Stress for Fatigue Analysis

4.1 Application

4.1.1 General

4.1.1.1 This Section describes the procedure to perform a finite element analysis using very fine meshes for the evaluation of geometric hot spot stresses for use in the determination of fatigue damage ratio in accordance with **Appendix C/2**.

4.1.1.2 The locations where a finite element analysis based fatigue assessment is to be carried out are specified in **Section 9/3.3**.

4.2 Structural Modelling

4.2.1 General

4.2.1.1 Evaluation of hot spot stresses for fatigue assessment requires the use of very fine finite element meshes in way of areas of high stress concentration. This very fine mesh analysis can be carried out by means of separate local finite element models with very fine mesh zones in conjunction with the boundary conditions obtained from a cargo tank model. Alternatively, very fine mesh zones incorporated into the cargo tank model may be used.

4.2.1.2 All structural parts, within an extent of at least 500mm in all directions leading up to the fatigue hot spot position, are to be modelled based on the net thickness, obtained by deducting half the corrosion addition (i.e. $0.5t_{corr}$) from the gross thickness.

4.2.1.3 The cargo tank finite element model for fatigue assessment is to be modelled in accordance with **2.2**, but based on net thickness obtained by deducting a quarter of the corrosion addition (i.e. $0.25t_{corr}$) from the proposed thickness. Alternatively, if the cargo tank FE model for the strength assessment is used, which is based on a thickness deduction of $0.5t_{corr}$, the calculated stresses are to be corrected using the modelling reduction factor, f_{model} , given in **Appendix C/2.4.2.7**.

4.2.1.4 Where a separate local finite element model is used, the extent of the local model is to be such that the calculated stresses are not significantly affected by the imposed boundary conditions and application of loads. The boundary of the fine mesh model is to coincide with the primary support members, such as girders, stringers and floors, in the cargo tank model. The extent of the local finite element model of a hopper knuckle is described in **4.2.2**.

4.2.1.5 The evaluation of hot spot stress is to be based on shell element of mesh size $t_{net50} \times t_{net50}$, where t_{net50} is the net thickness of the plate where a potential fatigue crack is most likely to initiate. This mesh size is to be maintained within the very fine mesh zone, extending over at least 10 elements in all directions leading to the fatigue hot spot position. A uniform quadratic mesh is to be used within the very fine mesh zone. A smooth transition of mesh density leading up to the very fine mesh zone is to be maintained.

4.2.1.6 Four-node shell elements with bending and membrane properties are to be used inside the very fine mesh zone. The shell elements are to represent the mid plane of the plating and the bending properties of the plate. The geometry of the weld and structural misalignment is not required to be modelled.

4.2.1.7 Where stresses are to be evaluated on a free edge or corner welds, such as cut-outs for stiffener connections at web frames, butt welds on edge of plating and around hatch corners, a rod element of negligible cross-section area, e.g. $1mm^2$, is to be used to obtain the required stress value.

4.2.1.8 All structure in close proximity to the very fine mesh zones is to be modelled explicitly with shell elements. Triangular elements are to be avoided where possible. Use of extreme aspect ratio (e.g. aspect ratio greater than 3) and distorted elements (e.g. element's corner angle less than 60° or greater than 120°) are to be avoided.

4.2.2 Hopper knuckle connection

4.2.2.1 In addition to the general requirements in **4.2.1**, the modelling requirements in this sub-section are applicable to the modelling of welded hopper knuckle connections.

4.2.2.2 Fatigue assessment is to be carried out for the knuckle joint between inner bottom and hopper plate for at least one transverse frame in the midship cargo tank region, see **Section 9/3.3.2**. The fatigue assessment is only required to be carried out on the structural detail at one side of the hull.

4.2.2.3 In general, the hopper knuckle connection at the mid position between transverse bulkheads is to be assessed. Where a wash bulkhead exists, the hopper knuckle connection at the mid position between the wash bulkhead and cargo tank end bulkhead is generally to be assessed. The results from the cargo tank FE analysis described in 2.2 should be examined for the highest transverse in-plane stress on the inner bottom plate adjacent to the lower hopper knuckle line to identify the exact frame position and the side of the hull where the fatigue assessment should be carried out.

4.2.2.4 Where a separate local finite element model is used, the minimum extent of the local model is as follows:

- (a) longitudinally, the model is to cover two web frame spaces (i.e. one web frame space extending either side of the transverse web frame of interest). Transverse web frames at the end of the local model need not to be represented in the sub-model
- (b) vertically, the model is to extend from the base line to the lower stringer in the double side water ballast tank. Where a fatigue assessment is also carried out for the upper knuckle connection, the model is to be extended to 4 longitudinal spaces above the lower stringer in the double side ballast tank
- (c) transversely, the model is to extend from the ship side to 4 longitudinal spaces inboard of the double bottom side girder.

4.2.2.5 Mesh size in way of the knuckle connection is to be $t_{net50} \times t_{net50}$, where t_{net50} is the net thickness of the inner bottom plate in way of the connection obtained by deducting $0.5t_{corr}$ from the gross thickness as specified in 4.2.1.2.

The minimum extent of the $t_{net50} \times t_{net50}$ mesh is to be (see also Fig. B.4.1):

- (a) inner bottom plate – 10 elements from knuckle in transverse direction, 10 elements forward and aft of the floor in the longitudinal direction
- (b) scarfing bracket/inner bottom overhang – 10 elements from knuckle in transverse direction, 10 elements forward and aft of the floor in the longitudinal direction
- (c) hopper sloping plate – 10 elements from knuckle in transverse direction, 10 elements forward and aft of the hopper web in the longitudinal direction
- (d) girder – 10 elements from knuckle in vertical direction, 10 elements forward and aft of the floor/hopper web in the longitudinal direction
- (e) floor/hopper web – 10 elements from the hopper knuckle in transverse and vertical directions respectively.

4.2.2.6 Any scarfing brackets on the web frame adjoining the inner bottom plating, the first longitudinal stiffeners away from the knuckle as well as any carlings and brackets offset from the main frames are to be modelled explicitly using shell elements. Longitudinal stiffeners further away from the knuckle may be modelled by beam elements. The inner bottom plate "overhang" outboard of the girder is to be modelled using shell elements up to the extent of the scarfing bracket. Away from the scarfing bracket, the inner bottom plate "overhang" may be modelled using line elements of equivalent area. Any perforations, such as cut-outs for cabling, pipes and access that are within one stiffener space from the knuckle point are to be modelled explicitly.

4.2.2.7 Fig. B.4.1 shows extent of the $t_{net50} \times t_{net50}$ mesh zone and extension of the areas of local thickness reduction.

4.2.2.8 Fig. B.4.2 to B.4.4 show typical local finite element models of the hopper knuckle connection and close-up views of the $t_{net50} \times t_{net50}$ mesh zone.

Fig. B.4.1 Minimum Extent of $t_{net50} \times t_{net50}$ Mesh Zone and Local Thickness Reduction Zone at Lower Hopper Joint

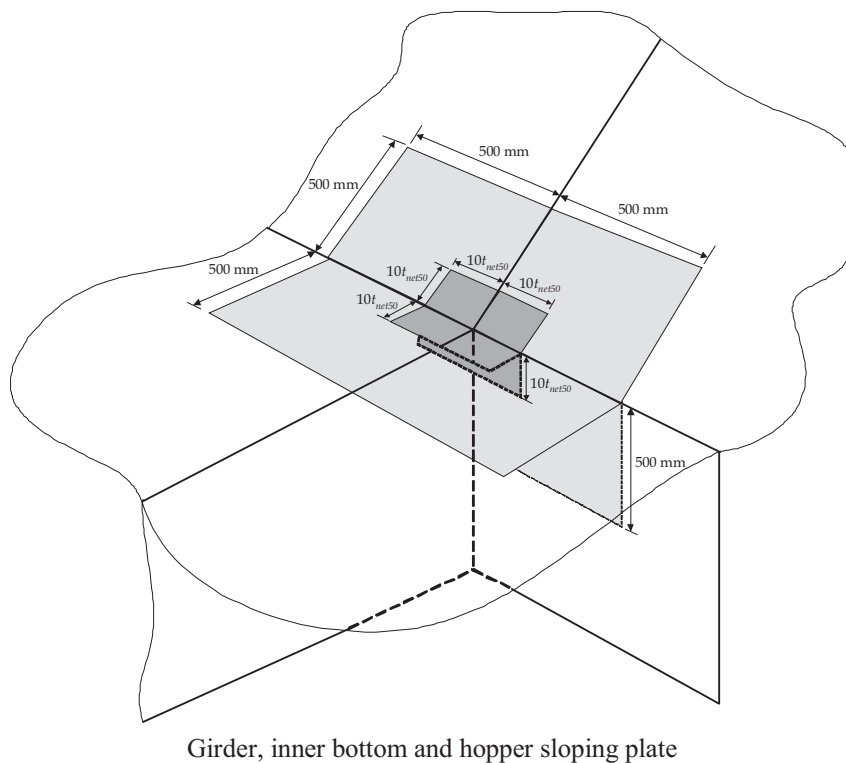
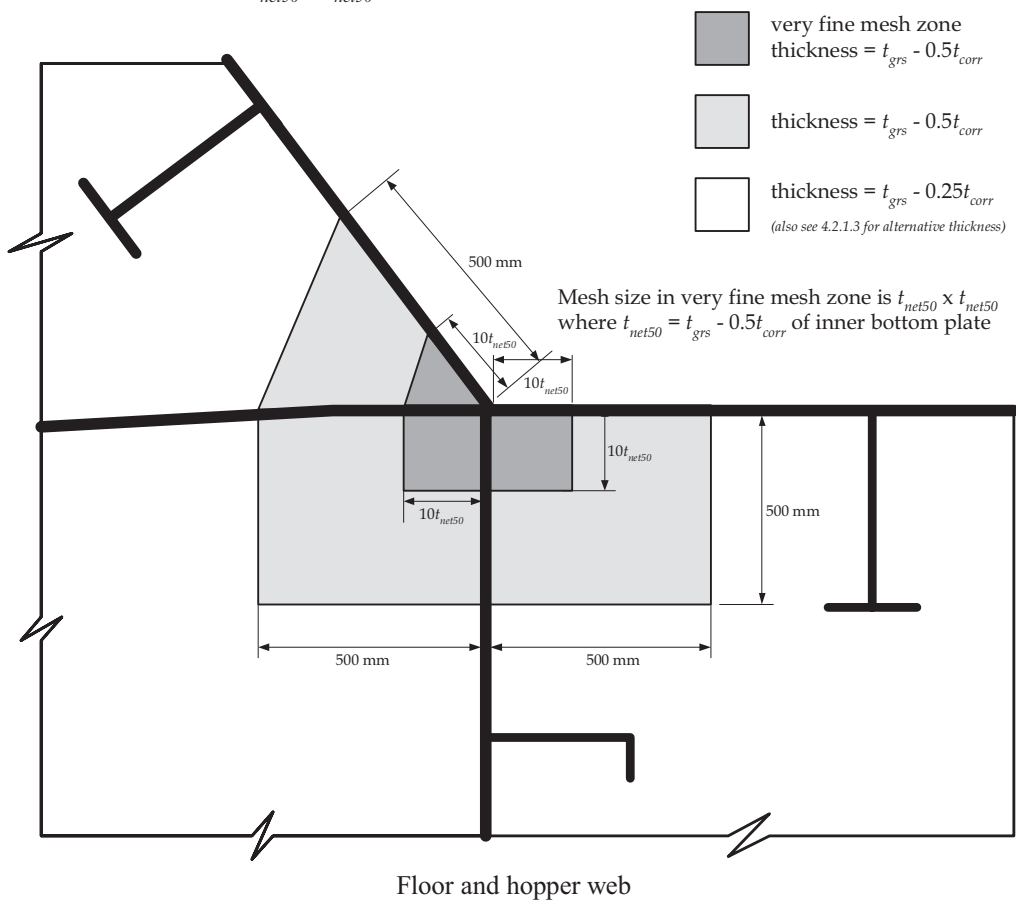

Fig. B.4.2 Typical Local Finite Element Model of Hopper Knuckle Connection $t_{net50} \times t_{net50}$ Mesh on Inner Bottom and Hopper Plate

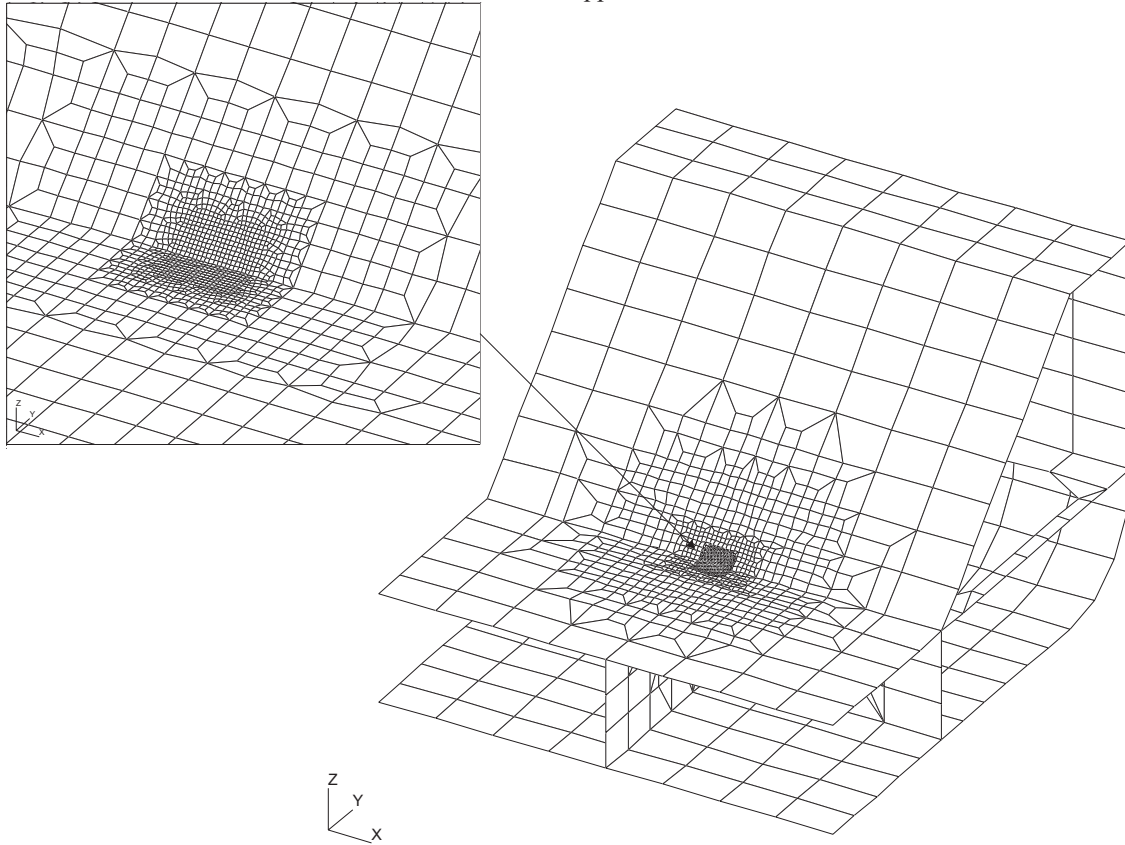

Fig. B.4.3 Typical Local Finite Element Model of Hopper Knuckle Connection $t_{net50} \times t_{net50}$ Mesh on Hopper Plate, Web Frame, Girder and Bracket in way

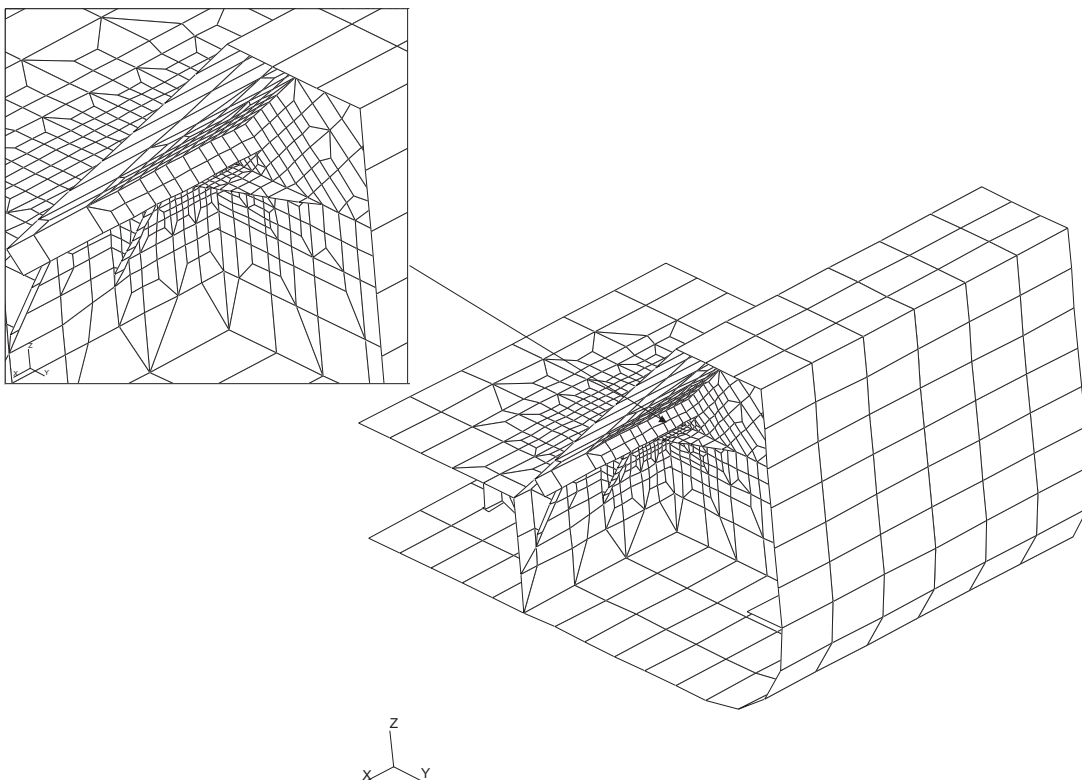
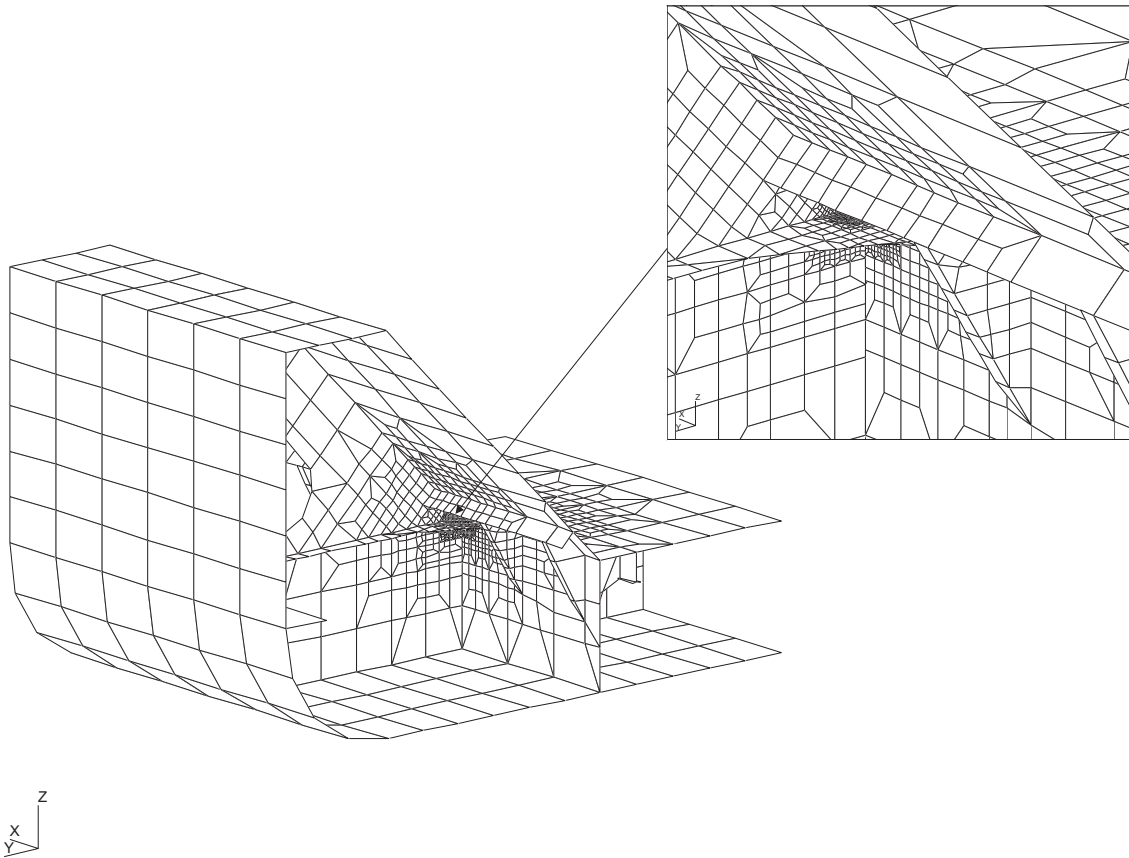

Fig. B.4.4 Typical Local Finite Element Model of Hopper Knuckle Connection $t_{net50} \times t_{net50}$ Mesh on Hopper Plate, Web Frame, Girder and Bracket in way



4.3 Loading Conditions

4.3.1 General

4.3.1.1 The ship loading conditions to be used to evaluate dynamic stress ranges for fatigue assessment are to be in accordance with **Appendix C/1.3.2**.

4.3.1.2 The cargo density to be used for the fatigue assessment is to be:

- (a) longitudinal end connections - the greater of the cargo density specified for the homogeneous scantling draught condition and $0.9t/m^3$
- (b) connection between inner bottom and hopper plate - $0.9t/m^3$.

4.3.2 Finite element load cases for hopper knuckle connection

4.3.2.1 The requirements given in this sub-section are specifically applicable to the evaluation of hot spot stress range at hopper knuckle connection.

4.3.2.2 Only dynamic loads are considered for the evaluation of fatigue stress range. Static loads need not be included in the finite element analysis.

4.3.2.3 The load cases required to derive the component stress ranges for determining the combined stress ranges, see **Appendix C/2.4.2.7**, are given in **Table B.4.1**.

4.3.2.4 Stresses induced by vertical and horizontal hull girder bending moments are not to be included in the stress range for fatigue assessment. Stress caused by the bending effect of the hull girder is to be calculated and deduced from the fatigue stress range result in accordance with the procedure described in **4.5.2**.

Table B.4.1 Load Cases for the Evaluation of Component Stress Range for Hopper Knuckle Joint

Load case	Component Stress	Applied Load	Parameters for calculation of loads
Full load condition			
L1	s_{e1}	Dynamic wave pressure (full range) applies only to the side of the hull where the hopper knuckle is analysed.	Ship draught = midship draught from departure homogeneous full load condition in the ship loading manual, see Appendix C/1.3.2 . GM: see Section 7/3.1.3.4 $r_{roll-gyr}$: see Section 7/3.1.3.4 Cargo density = $0.9t/m^3$ (minimum, see 4.3.1.2)
L2	s_{e2}	Dynamic wave pressure (full range) applies only to the side of the hull where the hopper knuckle is not analysed.	
L3	s_{ix}	Dynamic tank pressure (full range) due to longitudinal acceleration.	
L4	s_{iy}	Dynamic tank pressure (full range) due to transverse accelerations.	
L5	s_{iz}	Dynamic tank pressure (full range) due to vertical acceleration.	
Ballast condition			
L6	s_{e1}	Dynamic wave pressure (full range) applies only to the side of the hull where the hopper knuckle is analysed.	Ship draught = midship draught from departure normal ballast condition in the ship loading manual. If normal ballast condition is not defined, then the midship draught from light ballast condition is to be used, see Appendix C/1.3.2
L7	s_{e2}	Dynamic wave pressure (full range) applies only to the side of the hull where the hopper knuckle is not analysed.	
Load cases for bending moment correction			
C1	s_{VBM}	Unit vertical bending moment applies to ends of cargo tank model	No other loads are to be applied
C2	s_{HBM}	Unit horizontal bending moment applies to ends of cargo tank model	

Where:

- $s_{e1}, s_{e2}, s_{ix}, s_{iy}, s_{iz}$: component stresses (with proper sign convention used) before correction for bending moment effect ⁽⁵⁾
 s_{VBM} : stress response due to the application of unit vertical bending moment at ends of cargo tank model
 s_{HBM} : stress response due to the application of unit horizontal bending moment at ends of cargo tank models

Notes:

1. For dynamic wave pressure load cases, the pressure distribution is to be calculated at mid-ship and this distribution is to be applied along the full length of the cargo tank FE model.
2. For dynamic tank pressure load cases, vertical, transverse and longitudinal accelerations are calculated at the centre of gravity position of the midship cargo tanks. The accelerations calculated for each tank are to be applied to all corresponding cargo tanks along the length of the FE model.
3. Longitudinal, transverse and vertical accelerations at tank centre of gravity position are to be calculated in accordance with **Section 7/3.3**. The dynamic tank pressure amplitudes due to accelerations are to be calculated in accordance with **Section 7/3.5.4.7**. The dynamic tank pressure (full range) is to be obtained as two *times* the dynamic tank pressure amplitude and distributed in accordance with **Fig. 7.3.9**. Note that these pressure distributions are different from those used for strength analysis.
4. The dynamic wave pressure amplitude is to be calculated according to **Section 7/3.5.2.3**. The dynamic wave pressure (full range) is to be obtained as two *times* the dynamic wave pressure amplitude. Note that the dynamic wave pressure and distribution is different from that used for strength analysis.
5. Component stresses (with proper sign convention used) calculated from load cases L1 to L7 are to be corrected to deduct the component due to vertical and horizontal bending moment effect, see **4.5.2.2**.

4.4 Boundary Conditions

4.4.1 Cargo tank model

4.4.1.1 The boundary conditions to be applied to the ends of the cargo tank model are to be in accordance with 2.6. The application of unit vertical and horizontal bending moment at the model ends is to be in accordance with 2.5.4.5 or 2.5.4.6.

4.4.2 Local finite element models

4.4.2.1 Where a separate local finite element model is used for evaluating the hot spot stress range, the nodal displacements or equivalent nodal forces from the cargo tank model are to be applied to the corresponding boundary nodes on the local model.

4.4.2.2 Where there are nodes on the local model boundaries which are not coincident with the nodal points on the cargo tank model, it is acceptable to impose prescribed displacements on these nodes using multi-point constraints. The use of linear multi-point constraint equations connecting two neighbouring coincident nodes is considered sufficient.

4.4.2.3 All local loads in way of the structure represented by the separate local finite element model are to be applied to the model.

4.5 Result Evaluation

4.5.1 General

4.5.1.1 The fatigue damage calculation is to be based on the hot spot stress range evaluated close to the potential crack location in a direction perpendicular to the potential direction of the crack.

4.5.1.2 For welded structural details, the hot spot stress range is to be obtained as surface stress acting in a direction perpendicular to the weld at a distance of $0.5t_{net50}$ from the weld toe location, where t_{net50} is the net thickness of the plate where the fatigue crack is likely to initiate, see **Appendix C/2.4.2.6**.

4.5.1.3 For fatigue assessment of the free edge, a rod element is used to obtain stress at free edge. The stress range is to be based on the axial stress in the rod element.

4.5.1.4 For fatigue damage calculation of hopper knuckle connection, see 4.5.2.

4.5.2 Hopper knuckle connection

4.5.2.1 Hot spot stress ranges for fatigue assessment of welded hopper knuckle joints are to be based on element direct stress along a direction perpendicular to intersection of the inner bottom plate and hopper plate. The stress ranges are to be evaluated on the upper surface of the hopper and inner bottom plate at a distance of $0.5t_{net50} + x_{wt}$ from the intersection line, where t_{net50} is the net thickness of the inner bottom plate and x_{wt} is weld toe distance, see **Fig. C.2.1**. The stress at the required location can be obtained by linear interpolation based on the surface stresses evaluated at the centroid of the 1st and 2nd elements from the intersection of the hopper slope plate, and the inner bottom plate.

4.5.2.2 The component stress ranges are to be obtained by eliminating the stress induced by hull girder vertical and horizontal bending moments from the component stress determined from load cases L1 to L7 in **Table B.4.1** as follows:

$$S_{c_i} = \left| s_{c_i} - M_{V_i} S_{VBM} - M_{H_i} S_{HBM} \right|$$

Where:

- S_{c_i} : S_{e1} , S_{e2} , S_{ix} , S_{iy} or S_{iz} , component stress range after correction for bending moment effects
- s_{c_i} : s_{e1} , s_{e2} , s_{ix} , s_{iy} or s_{iz} , component stress (with proper sign convention used) including vertical and horizontal bending moment effects obtained from load cases L1 to L7, see **Table B.4.1**
- M_{V_i} : is the vertical hull girder bending moment due to loads applied to the cargo tank FE model obtained from load case L1, L2, L3, L4, L5, L6 or L7. The bending moment is to be calculated at the longitudinal position where the centroid of shell element under evaluation is located
- M_{H_i} : is the horizontal hull girder bending moment due to loads applied to the

cargo tank FE model obtained from load case L1, L2, L3, L4, L5, L6 or L7.

The bending moment is to be calculated at the longitudinal position where the centroid of shell element under evaluation is located

S_{VBM} : stress due to unit vertical bending moment obtained from load case C1, see

Table B.4.1

S_{HBM} : stress due to unit horizontal bending moment obtained from load case C2,

see **Table B.4.1**

4.5.2.3 The hull girder vertical and horizontal bending moments in **4.5.2.2** may be evaluated at the frame position where the hopper knuckle is under evaluation if the longitudinal distance from the element centroid to the frame position is less than $500mm$.

4.5.2.4 The component stress range, S_i , due to dynamic tank pressure resulting from longitudinal, transverse and vertical accelerations for the full load condition is given by:

$$S_i = 0.4|S_{ix}| + 0.9|S_{iy}| + 0.9|S_{iz}|$$

4.5.2.5 The combined hot spot stress ranges required for fatigue damage calculation are to be calculated in accordance with **Appendix C/2.4.2.7**.

4.5.2.6 Fatigue damage and fatigue life calculation is to be in accordance with **Appendix C/1.4.1**.

Appendix C FATIGUE STRENGTH ASSESSMENT

1. Nominal Stress Approach

1.1 General

1.1.1 Applicability

1.1.1.1 This sub-section defines the procedure for a simplified fatigue assessment which is to be used to evaluate the fatigue strength of the ships structural details. The fatigue assessment uses a nominal stress approach based on beam theory.

1.1.1.2 The fatigue assessment is to be applied to welded connections where the steel has a minimum yield strength of less than $400N/mm^2$.

1.1.2 Assumptions

1.1.2.1 The following assumptions are made in the fatigue assessment:

- (a) a linear cumulative damage model, i.e. Palmgren-Miner's Rule, has been used in connection with the S-N data in **1.4.5**
- (b) for longitudinal stiffener end connections, nominal stresses obtained by empirical formulae, see **1.4.2** to **1.4.4**, and Rule based loads, see **1.3**, form the basis of the nominal stress based fatigue assessment
- (c) the long term stress ranges of a structural detail can be characterized using a modified Weibull probability distribution parameter, ξ , as described in **1.4.1.5** and **1.4.1.6**
- (d) structural details are idealised and classified in **1.5**.

1.1.2.2 The structural detail classification in **1.5** is based on typical joint geometry under simple loadings. When a structural detail is considered different from those shown in **1.5**, a suitable finite element (FE) analysis should be used to demonstrate the adequacy of the detail in terms of fatigue strength. See **2.1.1.3**.

1.1.2.3 Where the loading or geometry considered is too complex for a simple classification, a finite element (FE) analysis of the detail is to be carried out to determine the fatigue stress of that detail. **Sub-section 2** defines the procedure for a finite element based assessment to determine hot spot stresses that is to be used for weld toe locations that are typically found at welded hopper knuckle connections in way of transverse primary support members. For bent type knuckle connections, recommendation is given in **2.1.1.2**.

1.2 Corrosion Model

1.2.1 Net thickness

1.2.1.1 The net thickness and corrosion additions, as indicated in **Section 6/3** are to be incorporated into the representation of the structural capacity models.

1.3 Loads

1.3.1 General

1.3.1.1 Ship structures are subjected to various types of loads, which include:

- (a) static loads including cargo and lightship weights
- (b) wave induced loads
- (c) impact loads, such as bottom slamming, bow flare impacts and sloshing in partially filled tanks
- (d) cyclic loads resulting from main engine or propeller induced vibratory forces
- (e) transient loads such as thermal loads
- (f) residual stresses.

1.3.1.2 The fatigue strength analysis considers the following wave induced loads for calculation of the long term distribution of stresses:

- (a) hull girder loads (i.e. vertical and horizontal wave bending moments)
- (b) dynamic wave pressures

(c) dynamic tank pressure loads resulting from ship motions.

1.3.2 Selection of loading conditions

1.3.2.1 Fatigue analyses are to be carried out for representative loading conditions according to the intended ship's operation. The following two loading conditions are to be examined:

- (a) full load condition at design draught at departure, T_{full} , see **Section 4/1.1.5.4**
- (b) ballast condition at normal ballast draught at departure, T_{bal-n} , see **Section 4/1.1.5.3**. If a normal ballast condition is not defined in the loading manual, minimum ballast draught, T_{bal} , see **Section 4/1.1.5.2**, should be used.

1.3.2.2 The relevant draught at midships is to be used for the determination of fatigue loads.

1.3.3 Determination of loads

1.3.3.1 Loads applied to the structure are to be calculated in order to determine the stress ranges for the relevant loading conditions.

1.3.3.2 Combined stresses resulting from the action of global and local loads are to be calculated in accordance with **1.4.4**, with consideration given to the probability level of 10^{-4} .

1.3.4 Vertical wave bending moment

1.3.4.1 The vertical wave bending moment is to be calculated based on **Section 7/3.4.1**. The pseudo amplitude (half range) values of the vertical wave bending moment,

$M_{wv-v-amp}$, for full load and ballast condition are to be taken as:

$$M_{wv-v-amp} = 0.5(M_{wv-hog} - M_{wv-sag}) \quad (kNm)$$

Where:

M_{wv-hog} : hogging vertical wave bending moment, in kNm

M_{wv-sag} : sagging vertical wave bending moment, in kNm

1.3.5 Horizontal wave bending moment

1.3.5.1 The horizontal wave bending moment is to be calculated based on **Section 7/3.4.2**. The pseudo amplitude (half range) values of the horizontal wave bending moment, $M_{wv-h-amp}$, for full load and ballast condition are to be taken as:

$$M_{wv-h-amp} = 0.5(M_{wv-h-pos} - M_{wv-h-neg}) \quad (kNm)$$

Where:

$M_{wv-h-pos}$: positive horizontal wave bending moment, in kNm
 $= M_{wv-h}$

$M_{wv-h-neg}$: negative horizontal wave bending moment, in kNm
 $= -M_{wv-h}$

1.3.6 Dynamic wave pressure

1.3.6.1 The dynamic wave pressure is to be calculated according to **Section 7/3.5.2**.

1.3.6.2 Considering the stretching of the external pressure due to intermittent wet and dry area, a pseudo amplitude of external pressure (half pressure range), P_{ex-amp} , is defined in **Section 7/3.5.2.3** in detail and illustrated in **Fig. C.1.1**.

Fig. C.1.1 Dynamic Pressure

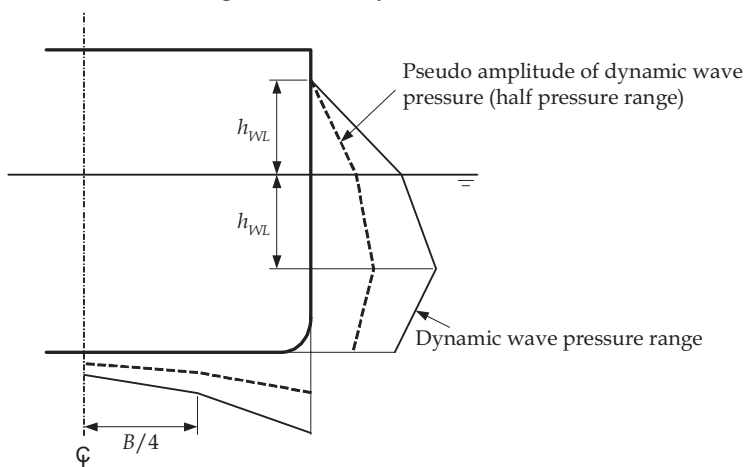

1.3.7 Dynamic tank pressure

1.3.7.1 The dynamic tank pressure amplitude, P_{in-amp} , is to be calculated according to **Section 7/3.5.4.5** and **Section 7/3.5.4.6**. No dynamic internal pressure is considered for the deck.

1.4 Fatigue Damage Calculation

1.4.1 Fatigue strength determination

1.4.1.1 The fatigue assessment of the structure is based on the application of the Palmgren-Miner cumulative damage rule given below. When the cumulative fatigue damage ratio, DM , is greater than 1, the fatigue capability of the structure is not acceptable. DM is to be taken as:

$$DM = \sum_{i=1}^{i=n_{tot}} \frac{n_i}{N_i}$$

Where:

n_i : number of cycles of stress range S_i

N_i : number of cycles to failure at stress range S_i

n_{tot} : total number of stress range blocks

1.4.1.2 Assessment of the fatigue strength of welded structural members includes the following three phases:

- calculation of stress ranges
- selection of the design S-N curve
- calculation of the cumulative damage.

1.4.1.3 The cumulative fatigue damage ratio, DM , is to be less than 1 for the design life of the ship. The design life is not to be less than 25 years. Unless otherwise specified the resultant cumulative damage is to be taken as:

$$DM = \sum_{i=1}^2 DM_i$$

Where:

DM_i : cumulative fatigue damage ratio for the applicable loading condition

$i = 1$ for full load condition

$= 2$ for normal ballast condition

1.4.1.4 Assuming the long term distribution of stress ranges fit a two-parameter Weibull probability distribution, the cumulative fatigue damage DM_i for each relevant condition is to be taken as:

$$DM_i = \frac{\alpha_i N_L}{K_2} \frac{S_{Ri}^m}{(\ln N_R)^{m/\xi}} \mu_i \Gamma\left(1 + \frac{m}{\xi}\right)$$

Where:

- N_L : number of cycles for the expected design life. Unless stated otherwise, N_L to be taken as

$$= \frac{f_0 U}{4 \log L_{CSR-T}}$$
: The value is generally between 0.6×10^8 and 0.8×10^8 cycles for a design life of 25 years
- f_0 : 0.85, factor taking into account non-sailing time for operations such as loading and unloading, repairs, etc.
- U : design life, in seconds
 $= 0.788 \times 10^9$ for a design life of 25 years
- L_{CSR-T} : rule length, in m , as defined in **Section 4/1.1.1.1**
- m : S-N curve parameter as defined in **1.4.5.5**
- K_2 : S-N curve parameter as defined in **1.4.5.5**
- α_i : proportion of the ship's life
 $\alpha_1 = 0.5$ for full load condition
 $\alpha_2 = 0.5$ for ballast condition
- S_{Ri} : stress range at the representative probability level of 10^{-4} , in N/mm^2
- N_R : 10 000, number of cycles corresponding to the probability level of 10^{-4}
- ξ : Weibull probability distribution parameter, as defined in **1.4.1.6**
- Γ : Gamma function
- μ_i : coefficient taking into account the change in slope of the S-N curve

$$\mu_i = 1 - \frac{\left\{ \gamma \left(1 + \frac{m}{\xi}, v_i \right) - v_i^{-\Delta m / \xi} \gamma \left(1 + \frac{m + \Delta m}{\xi}, v_i \right) \right\}}{\Gamma \left(1 + \frac{m}{\xi} \right)}$$
- v_i :
$$\left(\frac{S_q}{S_{Ri}} \right)^\xi \ln N_R$$
- S_q : stress range at the intersection of the two segments of the S-N curve, see **Table C.1.6**, in N/mm^2
- Δm : slope change of the upper-lower segment of the S-N curve
 $= 2$
- $\gamma(a,x)$: incomplete Gamma function, Legendre form

1.4.1.5 The probability density function of the long term distribution of stress ranges (hull girder + local bending) is to be represented by a two-parameter Weibull distribution. This assumption enables the use of a closed form equation for calculation of the fatigue life when the two parameters of the Weibull distribution are determined. The probability density function, $f(S)$, is to be taken as:

$$f(S) = \frac{\xi}{f_1} \left(\frac{S}{f_1} \right)^{\xi-1} \exp \left(- \left(\frac{S}{f_1} \right)^\xi \right)$$

Where:

- S : stress range, in N/mm^2
- ξ : Weibull probability distribution parameter, as defined in **1.4.1.6**
- f_1 : scale parameter

$$= \frac{S_R}{(\ln N_R)^{1/\xi}}$$

N_R : number of cycles corresponding to the probability of exceedance of $1/N_R$

S_R : stress range with probability of exceedance of $1/N_R$, in N/mm^2

1.4.1.6 For each structural detail considered, the Weibull shape parameter is to be selected with due consideration given to the load categories contributing to the cyclic stresses. The Weibull probability distribution parameter, ξ , is to be taken as:

$$\zeta = f_{Weibull} \left(1.1 - 0.35 \frac{L_{CSR-T} - 100}{300} \right)$$

Where:

L_{CSR-T} : rule length, in m , as defined in **Section 4/1.1.1.1**

D : moulded depth, in m , as defined in **Section 4/1.1.4.1**

$f_{Weibull}$: area dependent modification factor, as given in **Table C.1.1** and **Fig. C.1.2**

Table C.1.1 Distribution of $f_{Weibull}$ factors

Plating Area	$f_{Weibull}$ (see note)
Bottom	0.9 at centreline and 0.95 at side
Side and bilge	1.1 at up to draught T_{LC} and 1.0 at deck
Deck	1.0
Inner bottom	1.0
Inner Hull Longitudinal Bulkhead	1.1 up to $D/2$ and 1.0 at deck
Inner Longitudinal Bulkhead	1.1 up to $D/2$ and 1.0 at deck
Centreline Longitudinal Bulkhead	1.1 up to $D/2$ and 1.0 at deck

Note: Intermediate values to be linearly interpolated

Fig. C.1.2 Distribution of $f_{Weibull}$ factors

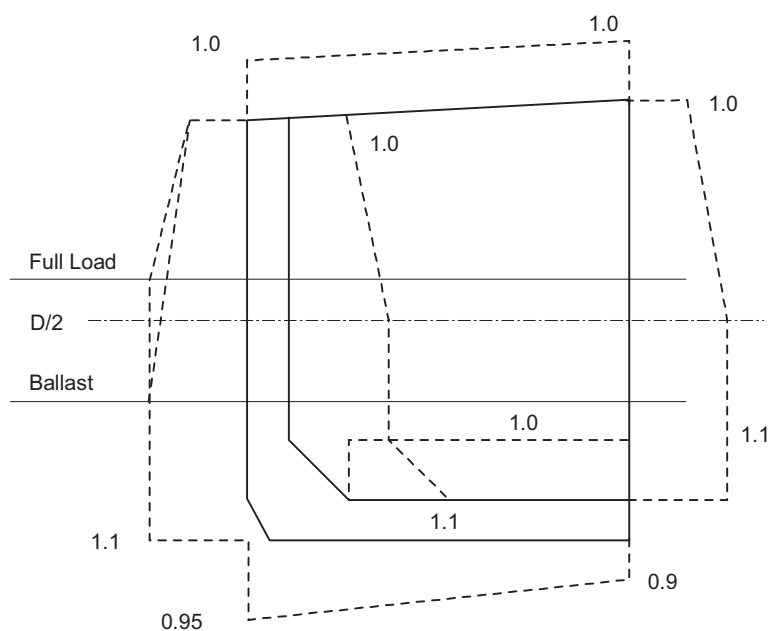

1.4.1.7 The cumulative fatigue damage ratio, DM , may be converted to a calculated fatigue life using the relationship given below. In this format, the calculated fatigue life is to be equal or greater than the design life of the ship.

$$\text{Fatigue life} = \frac{\text{Design life}}{DM} \quad (\text{years})$$

1.4.2 Stresses to be used

1.4.2.1 The nominal stresses are to be determined taking into account the overall geometric changes of the detail. The effect of stress concentrations due to structural discontinuities, presence of attachments and the weld profile is not considered.

1.4.3 Nominal stress calculation

1.4.3.1 This Sub-Section outlines a simplified approach to determine the combination of global and local stress components of the stress response of the ship.

1.4.3.2 Stress responses are to be calculated with varying levels of detail. The following approach has been adopted in this simplified procedure:

- (a) the hull girder is treated as a simple beam as a way of obtaining reasonable approximations to the nominal stress level in longitudinal hull girder elements. This is used for the evaluation of hull girder stress levels in way of critical details
- (b) the structural member with effective attached plating is used in determining the nominal stress response of longitudinal and transverse frames due to dynamic wave pressure and dynamic tank pressure loads. The member end restraints and moments are considered.

1.4.4 Definition of stress components

1.4.4.1 Dynamic stress variations are referred to as either *stress range*, S , or *stress amplitude*, σ .

1.4.4.2 The global dynamic stress components (primary stresses) considered in fatigue analysis are vertical wave hull girder bending stress, σ_v , and horizontal wave hull girder bending stress, σ_h .

1.4.4.3 The local dynamic stress amplitudes considered are defined as the total local stress amplitude due to dynamic wave pressure loads or dynamic tank pressure loads, σ_{e-i} .

1.4.4.4 The local stress components are defined as secondary stress resulting from bending of girder systems, σ_2 , stress amplitude produced by bending of stiffeners between girder supports, σ_{2A} , and tertiary stress amplitude produced by bending of un-stiffened plate elements between longitudinals and transverse frames, σ_3 . See **Fig. C.1.3**.

1.4.4.5 The total local stress due to dynamic wave or dynamic tank pressure loads, σ_{e-i} , is to be taken as:

$$\sigma_{e-i} = \sigma_2 + \sigma_{2A} + \sigma_3 \quad (N/mm^2)$$

Where:

σ_2 : local stress component, in N/mm^2 , as defined in 1.4.4.4

σ_{2A} : local stress component, in N/mm^2 , as defined in 1.4.4.4

σ_3 : local stress component, in N/mm^2 , as defined in 1.4.4.4

Fig. C.1.3 Definition of Local Stress Components

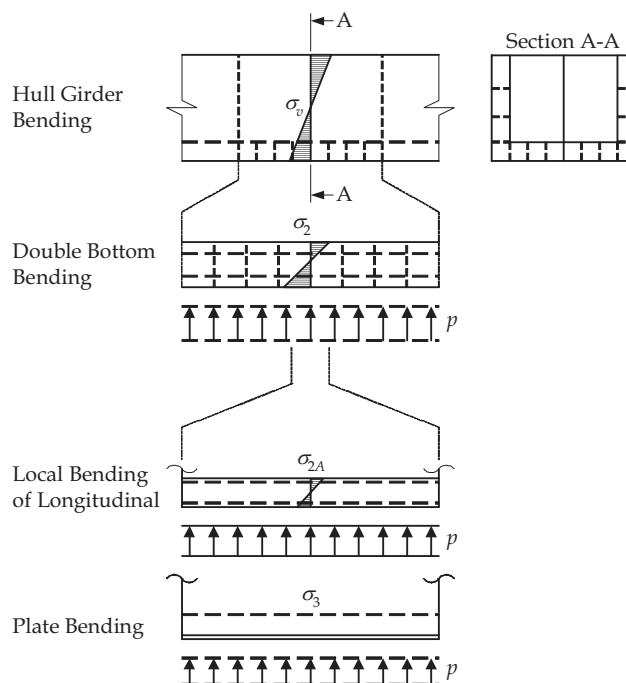

1.4.4.6 For the calculation of stress components, the vertical wave hull girder stress, σ_v , is given by:

$$\sigma_v = \frac{M_{wv-v-amp}}{Z_{v-net75}} 10^{-3} \quad (N/mm^2)$$

Where:

$M_{wv-v-amp}$: pseudo amplitude (half range), in kNm , as defined in **1.3.4**

$$Z_{v-net75} = \frac{I_{v-net75}}{|z - z_{NA-net75}|} \quad (m^3) \quad \text{see Section 4/2.6.1}$$

$I_{v-net75}$: net vertical hull girder moment of inertia, of hull cross-section about transverse neutral axis, in m^4

$I_{v-net75}$ is to be calculated based on gross thickness, minus the corrosion addition $0.25t_{corr}$ of all effective structural elements, see **Section 4/2.6.1**

z : distance from baseline to the critical location of the considered member, i.e. top of flange of longitudinal stiffener, in m

$z_{NA-net75}$: distance from baseline to horizontal neutral axis consistent with $I_{v-net75}$, in m

1.4.4.7 The corresponding stress range due to vertical wave bending moment, S_v , is to be taken as:

$$S_v = 2\sigma_v \quad (N/mm^2)$$

Where:

σ_v : vertical wave hull girder stress, in N/mm^2 , as defined in **1.4.4.6**

1.4.4.8 The horizontal wave hull girder stress, σ_h , is to be taken as:

$$\sigma_h = \frac{M_{wv-h-amp}}{Z_{h-net75}} 10^{-3} \quad (N/mm^2)$$

Where:

$M_{wv-h-amp}$: in kNm , as defined in **1.3.5**

$$Z_{h-net75} = \frac{I_{h-net75}}{|y|} \quad (m^3) \quad \text{see Section 4/2.6.2}$$

y : distance from vertical neutral axis of hull cross section to the critical location of the considered member, in m . i.e. top of face plate of longitudinal stiffener

$I_{h-net75}$: net horizontal hull girder moment of inertia, of the hull cross-section about the vertical neutral axis, in m^4 .

$I_{h-net75}$ is to be calculated based on gross thickness, minus the corrosion addition $0.25t_{corr}$ for all effective structural elements, see **Section 4/2.6.2**

1.4.4.9 The corresponding stress range due to horizontal wave bending moment, S_h , is to be taken as:

$$S_h = 2\sigma_h \quad (N/mm^2)$$

Where:

σ_h : horizontal wave hull girder stress, in N/mm^2 , as defined in **1.4.4.8**

1.4.4.10 The effect of secondary stress σ_2 , as defined in **1.4.4.4**, is in general small for double hull tankers and is therefore not taken into consideration.

1.4.4.11 The stress amplitude produced by bending of stiffeners between girder supports (e.g. frames, bulkheads), σ_{2A} , is to be taken as:

$$\sigma_{2A} = K_n K_d \frac{M}{Z_{net50}} 10^3 \quad (N/mm^2)$$

Where:

K_n : stress factor for unsymmetrical profiles, as defined in **1.4.4.15**

K_d : stress factor for bending stress in longitudinal stiffeners caused by relative deformation between supports, may be determined by FE analysis of the cargo hold model where the actual relative deformation is taken into account or taken as follows

- 1.0 at frame connections
- 1.15 for all longitudinals at transverse bulkhead connections including wash bulkheads except
 - (a) in full load condition:
 - 1.3 for side and bilge longitudinals at mid position between lowest side stringer and deck at side
 - 1.15 for side and bilge longitudinals at lowest side stringer and deck at side
 to be linearly interpolated between these two positions
 - 1.5 for bottom longitudinals at mid position between longitudinal bulkhead, bottom girders or buttress structure
 - 1.15 for bottom longitudinals at longitudinal bulkhead, bottom girders or buttress structure
 to be linearly interpolated between these two positions

See **Fig. C.1.4**

- (b) in ballast condition:
 - 1.5 for bottom longitudinals in the mid position between longitudinal bulkhead, bottom girders or buttress structure
 - 1.15 for bottom longitudinals at longitudinal bulkhead, bottom girders or buttress structure
 to be linearly interpolated between these two positions

M : moment at stiffener support adjusted to weld toe location at the stiffener (e.g. at bracket toe), in kNm

$$= \frac{Ps l_{bdg}^2 10^{-3}}{12} r_p$$

s : stiffener spacing, in mm

l_{bdg} : effective bending span, of longitudinal stiffener, as shown in **Fig. C.1.5**, in m . See also **Fig. 4.2.1** and **4.2.2** in **Section 4** for soft toe brackets. Top stiffeners with a soft toe are to be treated the same as flat bars with a soft toe bracket. The span point is to be taken at the point where the depth of the end bracket, measured from the face of the member, is equal to half the depth of the member

Z_{net50} : section modulus of longitudinal stiffener with associated effective plate flange b_{eff} , in cm^3 , calculated based on gross thickness minus the corrosion addition $0.5t_{corr}$.

b_{eff} : as defined in **Section 4/2.3.3**

r_p : moment interpolation factor, for interpolation to weld toe location along the stiffener length

$$= \left| 6 \left(\frac{x}{l_{bdg}} \right)^2 - 6 \left(\frac{x}{l_{bdg}} \right) + 1.0 \right| \quad \text{where} \quad 0 \leq x \leq l_{bdg}$$

: where x is the distance to the hot spot, in m . See **Fig. C.1.5**.

P : lateral dynamic pressure amplitude at the mid-span between the frame considered and the neighbouring frame, in kN/m^2 .

: P_{in-amp} for dynamic tank pressure, is to be taken as defined in **1.3.7**

: P_{ex-amp} for dynamic wave pressure, is to be taken as defined in **1.3.6**

Fig. C.1.4 Variation of Bulkhead Factor K_d in Full Load Condition for a Vessel with Two Longitudinal Bulkheads

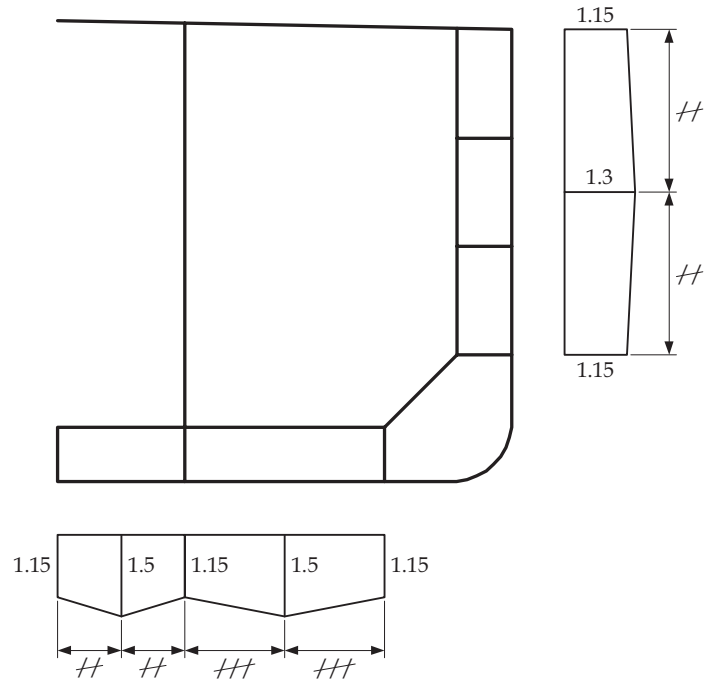
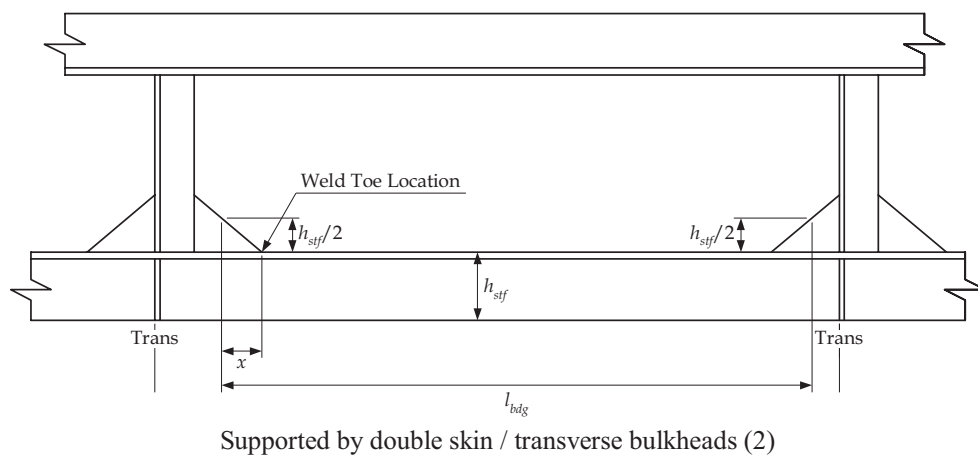
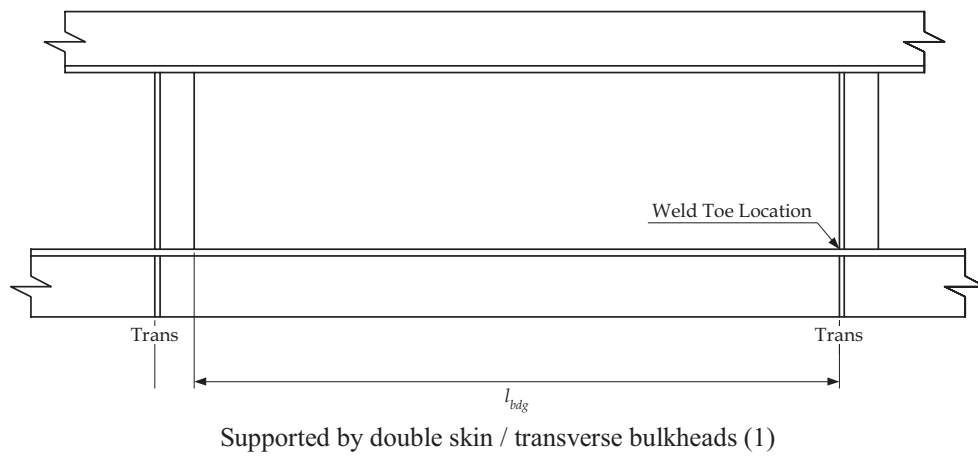
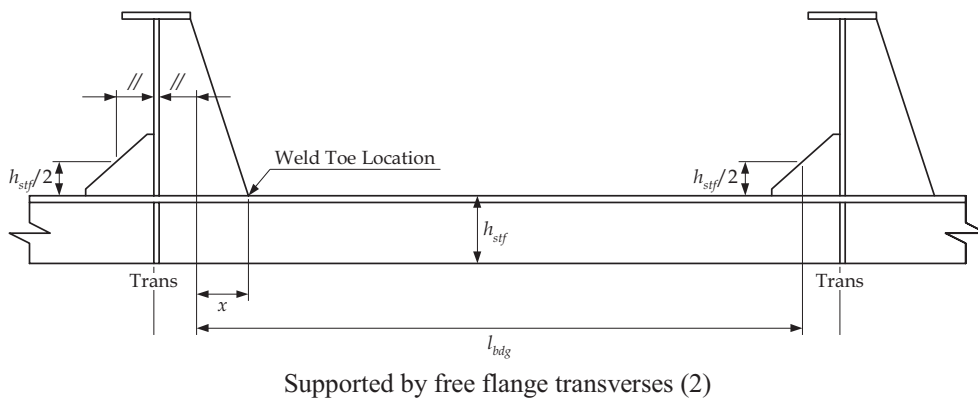
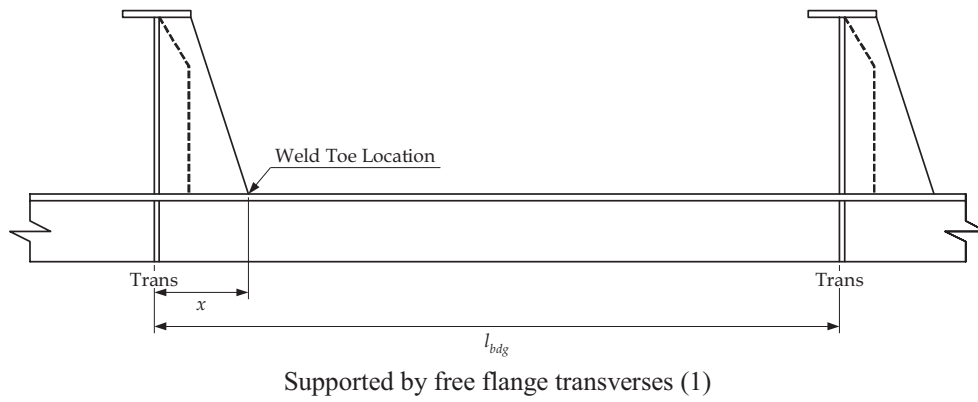

Fig. C.1.5 Definition of Effective Span Lengths



1.4.4.12 The stress range due to external wave or internal tank pressure, S_e or S_i , is to be determined as:

$$S_e = 2\sigma_{2Ae} \quad (N/mm^2)$$

$$S_i = 2\sigma_{2Ai} \quad (N/mm^2)$$

Where:

σ_{2Ae} : stress amplitude, in N/mm^2 , as defined in 1.4.4.11 when P_{ex-amp} is used

σ_{2Ai} : stress amplitude, in N/mm^2 , as defined in 1.4.4.11 when P_{in-amp} is used

1.4.4.13 Longitudinal local tertiary plate bending stress amplitude in the weld at the plate, transverse frame or bulkhead intersection, σ_3 , is not relevant to the critical locations being considered and is to be neglected.

1.4.4.14 The effective breadth of plate flanges of stiffeners (longitudinals) in bending (due to the shear lag effect), exposed to uniform lateral load for bending at ends, is defined in **Section 4/2.3.3**.

1.4.4.15 The stress concentration factors at the flange of un-symmetrical stiffeners on laterally loaded panels, K_{n1} and K_{n2} , as shown in **Fig. C.1.6**, are to be taken as:

$$K_{n1} = \frac{1 + \lambda\beta}{1 + \lambda\beta^2\psi_z} \quad \text{at the flange edge}$$

$$K_{n2} = \frac{1 + \lambda\beta^2}{1 + \lambda\beta^2\psi_z} \quad \text{at the web}$$

K_{n2} is typically used in the fatigue analysis of longitudinal end connections

Where:

$$\beta : 1 - \frac{2b_g}{b_f} \quad \text{for built-up profiles}$$

$$1 - \frac{t_{w-net50}}{b_f} \quad \text{for rolled angle profiles}$$

b_g : breadth of flange from web centreline, in mm , see **Fig. C.1.7**

$t_{w-net50}$: net web thickness, in mm

d_w : depth of stiffener web, see **Fig. C.1.7, in mm**

λ : factor, as defined in 1.4.4.17

ψ_z : ratio between section modulus of the stiffener web with plate flange, as calculated at the flange and the section modulus of the complete panel stiffener

$$\frac{d_w^2 t_{w-net50}}{4Z_{net50} 10^3} \quad \text{may be used as an approximate value}$$

Z_{net50} : section modulus of stiffener including the full width of the attached plate, s , with respect to a neutral axis normal to the stiffener web, in cm^3 . It is to be calculated based on the gross thickness minus the corrosion addition $0.5t_{corr}$

Fig. C.1.6 Bending Stress in Symmetrical and Un-symmetrical Panel Stiffener with Same Web and Flange Areas

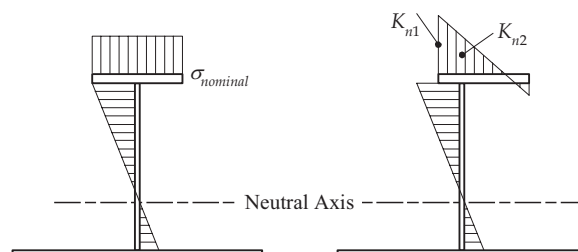
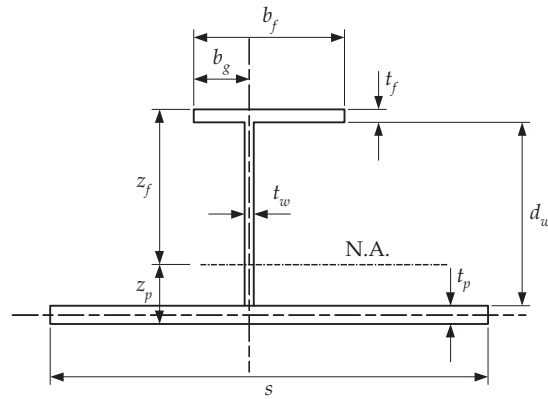

Fig. C.1.7 Stiffener Geometry



1.4.4.16 The formulations are not directly applicable for bulb profiles. For these, the equivalent built-up profile is to be considered, see **Fig. C.1.8**. The assumed built-up flange is to have the same properties as the bulb flange for cross-sectional area and moment of inertia about the vertical axis and neutral axis position. For HP bulb profiles, the equivalent built up profile dimensions are to be determined. Several examples are tabulated in **Table C.1.2**.

1.4.4.17 For continuous stiffeners (fixed ends) the λ -factor at supports is to be taken as:

$$\lambda = \frac{3(1 + \frac{\eta}{280})}{1 + \frac{\eta}{40}}$$

Where:

$$\eta = \frac{l_{bdg}^4 \cdot 10^{12}}{b_f^3 t_{f-net50} h_{stf}^2 \left(\frac{4h_{stf}}{t_{w-net50}^3} + \frac{s}{t_{p-net50}^3} \right)}$$

- l_{bdg} : effective bending span, of longitudinal stiffener, in *m*
- b_f : breadth of flange, in *mm*
- $t_{f-net50}$: net flange thickness, in *mm*
- h_{stf} : stiffener height, including face plate, in *mm*
- $t_{w-net50}$: net web thickness, in *mm*
- $t_{p-net50}$: net plate thickness, in *mm*
- s : plate width between stiffeners, in *mm*

Fig. C.1.8 Bulb Profile and Equivalent Built-up Flange

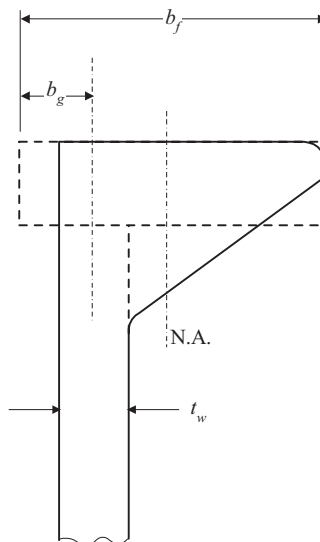

Table C.1.2 HP Equivalent Built-up Profile Dimensions

HP- bulb		Equivalent built-up flange		
Height (mm)	Web thickness t_w (mm)	b_f (mm)	t_f (mm)	b_g (mm)
200	9 – 13	$t_w + 24.5$	22.9	$(t_w + 0.9)/2$
220	9 – 13	$t_w + 27.6$	25.4	$(t_w + 1.0)/2$
240	10 – 14	$t_w + 30.3$	28.0	$(t_w + 1.1)/2$
260	10 – 14	$t_w + 33.0$	30.6	$(t_w + 1.3)/2$
280	10 – 14	$t_w + 35.4$	33.3	$(t_w + 1.4)/2$
300	11 – 16	$t_w + 38.4$	35.9	$(t_w + 1.5)/2$
320	11 – 16	$t_w + 41.0$	38.5	$(t_w + 1.6)/2$
340	12 – 17	$t_w + 43.3$	41.3	$(t_w + 1.7)/2$
370	13 – 19	$t_w + 47.5$	45.2	$(t_w + 1.9)/2$
400	14 – 19	$t_w + 51.7$	49.1	$(t_w + 2.1)/2$
430	15 – 21	$t_w + 55.8$	53.1	$(t_w + 2.3)/2$

1.4.4.18 For each loading condition, combined local stress components due to simultaneous dynamic tank and dynamic wave pressure loads are to be combined with global stress components induced by hull girder wave bending.

1.4.4.19 Total combined stress range, S , is given by:

$$S = f_{SN} | f_1 S_v + f_2 S_h + f_3 S_e + f_4 S_i | \quad (N/mm^2)$$

Where:

f_1, f_2, f_3 and f_4 : stress range combination factors, representing the phase correlation between total stress range and each stress range component which is between 1.0 and -1.0, as defined in **Tables C.1.3 to C.1.5**. Where the factor is greater than 1.0 it is to be taken as 1.0. Where the factor is less than -1.0 it is to be taken as -1.0

f_{SN} : 1.06, factor to account for joints in combined protected and unprotected environment.
 S_v : corresponding stress range due to vertical bending moment, in N/mm^2 , as defined in **1.4.4.7**

S_h : corresponding stress range due to horizontal bending moment, in N/mm^2 , as defined in **1.4.4.9**

S_e : stress range due to external wave or internal tank pressure, in N/mm^2 , as defined in **1.4.4.12**

S_i : stress range due to external wave or internal tank pressure, in N/mm^2 , as defined in **1.4.4.12**

1.4.4.20 The stress range combination factors, f_1, f_2, f_3 and f_4 , which are to be applied to the following zones, are given in **Tables C.1.3 to C.1.5**:

- Zone M: Midship region. This zone extends over the full length of all tanks where the tank LCG lies between $0.35L_{CSR-T}$ and $0.8L_{CSR-T}$ from AP.
- Zone A: Aft region. This zone starts at the middle of the tank immediately aft of Zone M and extends aftwards to include all the aftmost tanks.
- Zone F: Forward region. This zone starts at the middle of the tank immediately forward of Zone M and extends forwards to include all the foremost tanks.
- Zone AT: Aft transition region between Zone M and Zone A. The stress range combination factors are to be calculated by linear interpolation between the stress range combination factors for Zones M and A.
- Zone FT: Forward transition region between Zone M and Zone F. The stress range combination factors are to be calculated by linear interpolation between the stress range combination factors for Zones M and F.

Note:

Where ballast tanks, centre and wing cargo tanks do not have the same lengths e.g. if slop tank is present, the middle position is to be taken at the middle of the longer tank.

Table C.1.3 Stress Range Combination Factors for Zone M

	Stiffener location		f_1	f_2	f_3	f_4	f_i
Ballast	Bottom shell	a_i	-0.49	0.49	-1.04	-0.13	$a_i (y /B) + b_i$
		b_i	0.97	0.17	0.87	0.56	
	Side shell and bilge below $D/2$	a_i	-1.48	0.50	-0.64	0.72	$a_i (z/D) + b_i$
		b_i	0.94	0.40	0.72	0.04	
	Side shell above $D/2$	a_i	1.70	-1.00	-1.10	-0.60	$a_i (z/D) + b_i$
		b_i	-0.65	1.15	0.95	0.70	
	Inner bottom and Lower stool	a_i	-0.18	0.34	0.00	-0.30	$a_i (y /B) + b_i$
		b_i	0.90	0.22	0.00	0.74	
	Inner hull below $D/2$ (including hopper plate)	a_i	-1.70	-0.90	0.00	1.04	$a_i (z/D) + b_i$
		b_i	1.15	0.70	0.00	0.45	
	Inner hull above $D/2$	a_i	1.40	0.50	0.00	-1.94	$a_i (z/D) + b_i$
		b_i	-0.40	0.00	0.00	1.94	
	Deck and Upper stool	a_i	-0.15	1.05	0.00	0.00	$a_i (y /B) + b_i$
		b_i	1.02	-0.27	0.00	0.00	
	Centreline longitudinal bulkhead Below $D/2$	a_i	0.00	0.00	0.00	0.00	$a_i (z/D) + b_i$
		b_i	1.00	0.00	0.00	0.00	
	Centreline longitudinal bulkhead Above $D/2$	a_i	0.00	0.00	0.00	0.00	$a_i (z/D) + b_i$
		b_i	1.00	0.00	0.00	0.00	
	Longitudinal bulkhead below $D/2$	a_i	-0.20	1.30	0.00	0.00	$a_i (z/D) + b_i$
		b_i	1.00	0.10	0.00	0.00	
Longitudinal bulkhead above $D/2$	a_i	0.20	-1.30	0.00	0.00	$a_i (z/D) + b_i$	
	b_i	0.80	1.40	0.00	0.00		
Loaded	Bottom shell	a_i	-0.43	0.78	-0.77	0.00	$a_i (y /B) + b_i$
		b_i	0.98	0.13	0.75	0.00	
	Side shell and bilge below $D/2$	a_i	-0.29	-0.47	0.14	0.00	$a_i (z/D) + b_i$
		b_i	0.19	0.78	0.92	0.00	
	Side shell above $D/2$	a_i	1.77	-0.05	-1.20	0.00	$a_i (z/D) + b_i$
		b_i	-0.84	0.57	1.59	0.00	
	Inner bottom and Lower stool	a_i	-0.71	1.13	0.00	0.55	$a_i (y /B) + b_i$
		b_i	1.03	0.18	0.00	-0.18	
	Inner hull below $D/2$ (including hopper plate)	a_i	-0.80	-1.70	0.00	2.60	$a_i (z/D) + b_i$
		b_i	0.55	1.20	0.00	-0.35	
	Inner hull above $D/2$	a_i	1.90	0.30	0.00	-1.70	$a_i (z/D) + b_i$
		b_i	-0.80	0.20	0.00	1.80	
	Deck and Upper stool	a_i	-0.26	1.40	0.00	0.00	$a_i (y /B) + b_i$
		b_i	1.02	-0.16	0.00	0.00	
	Centreline longitudinal bulkhead below $D/2$	a_i	-1.40	0.00	0.00	1.00	$a_i (z/D) + b_i$
		b_i	0.75	0.00	0.00	0.60	
	Centreline longitudinal bulkhead above $D/2$	a_i	1.70	0.00	0.00	-1.20	$a_i (z/D) + b_i$
		b_i	-0.80	0.00	0.00	1.70	
	Longitudinal bulkhead below $D/2$	a_i	-0.60	0.40	0.00	1.10	$a_i (z/D) + b_i$
		b_i	1.00	0.40	0.00	0.05	
Longitudinal bulkhead above $D/2$	a_i	0.60	-0.84	0.00	-0.84	$a_i (z/D) + b_i$	
	b_i	0.40	1.02	0.00	1.02		

Table C.1.4 Stress Range Combination Factors for Zone A

	Stiffener location		f_1	f_2	f_3	f_4	f_i
Ballast	Bottom shell	a_i	-0.20	-0.80	1.20	1.50	$a_i (y /B) + b_i$
		b_i	0.00	0.50	-0.25	1.07	
	Side shell and bilge below $D/2$	a_i	-1.00	1.20	-0.80	2.00	$a_i (z/D) + b_i$
		b_i	0.20	0.00	0.60	-0.40	
	Side shell above $D/2$	a_i	3.40	-1.20	-2.80	0.80	$a_i (z/D) + b_i$
		b_i	-2.00	1.20	1.60	0.20	
	Inner bottom and Lower stool	a_i	-0.50	-1.90	0.00	0.30	$a_i (y /B) + b_i$
		b_i	-0.05	0.60	0.00	0.85	
	Inner hull below $D/2$	a_i	8.20	-2.80	0.00	0.20	$a_i (z/D) + b_i$
		b_i	-3.50	1.00	0.00	0.90	
	Inner hull above $D/2$	a_i	0.60	2.80	0.00	-0.50	$a_i (z/D) + b_i$
		b_i	0.30	-1.80	0.00	1.25	
	Deck and Upper stool	a_i	0.00	0.70	0.00	0.00	$a_i (y /B) + b_i$
		b_i	1.00	0.00	0.00	0.00	
	Inner longitudinal bulkhead Below $D/2$	a_i	-1.20	2.00	0.00	0.00	$a_i (z/D) + b_i$
		b_i	1.10	0.00	0.00	0.00	
	Inner longitudinal bulkhead Above $D/2$	a_i	1.50	-2.70	0.00	0.00	$a_i (z/D) + b_i$
		b_i	-0.25	2.35	0.00	0.00	
	Centreline longitudinal bulkhead Below $D/2$	a_i	0.00	0.00	0.00	0.00	$a_i (z/D) + b_i$
		b_i	1.00	0.00	0.00	0.00	
Centreline longitudinal bulkhead Above $D/2$	a_i	0.00	0.00	0.00	0.00	$a_i (z/D) + b_i$	
	b_i	1.00	0.00	0.00	0.00		
Loaded	Bottom shell	a_i	-2.20	1.50	2.60	0.00	$a_i (y /B) + b_i$
		b_i	1.20	-0.15	-0.30	0.00	
	Side shell and bilge below $D/2$	a_i	-1.20	-1.20	0.60	0.00	$a_i (z/D) + b_i$
		b_i	0.30	0.80	0.70	0.00	
	Side shell above $D/2$	a_i	3.00	-0.30	-0.50	0.00	$a_i (z/D) + b_i$
		b_i	-1.80	0.35	1.25	0.00	
	Inner bottom and Lower stool	a_i	-1.00	2.30	0.00	-0.20	$a_i (y /B) + b_i$
		b_i	1.00	-0.10	0.00	0.00	
	Inner hull below $D/2$	a_i	-0.80	1.00	0.00	1.00	$a_i (z/D) + b_i$
		b_i	0.20	0.00	0.00	0.50	
	Inner hull above $D/2$	a_i	3.20	-1.00	0.00	-0.80	$a_i (z/D) + b_i$
		b_i	-1.80	1.00	0.00	1.40	
	Deck and Upper stool	a_i	-0.10	1.50	0.00	0.00	$a_i (y /B) + b_i$
		b_i	1.00	-0.15	0.00	0.00	
	Inner longitudinal bulkhead Below $D/2$	a_i	-0.80	0.30	0.00	1.00	$a_i (z/D) + b_i$
		b_i	1.00	0.50	0.00	0.30	
	Inner longitudinal bulkhead Above $D/2$	a_i	0.20	-0.90	0.00	-0.08	$a_i (z/D) + b_i$
		b_i	0.50	1.10	0.00	0.84	
	Centreline longitudinal bulkhead Below $D/2$	a_i	-1.10	0.00	0.00	0.44	$a_i (z/D) + b_i$
		b_i	0.60	0.00	0.00	0.80	
Centreline longitudinal bulkhead Above $D/2$	a_i	1.30	0.00	0.00	-0.56	$a_i (z/D) + b_i$	
	b_i	-0.60	0.00	0.00	1.30		

Table C.1.5 Stress Range Combination Factors for Zone F

	Stiffener location		f_1	f_2	f_3	f_4	f_i
Ballast	Bottom shell	a_i	-0.90	1.00	2.40	-1.20	$a_i (y /B) + b_i$
		b_i	0.85	-0.10	-1.00	1.10	
	Side shell and bilge below $D/2$	a_i	-0.60	-0.40	1.00	-1.80	$a_i (z/D) + b_i$
		b_i	0.00	0.50	-0.15	0.90	
	Side shell above $D/2$	a_i	0.60	-0.90	-2.70	3.00	$a_i (z/D) + b_i$
		b_i	-0.60	0.75	1.70	-1.50	
	Inner bottom and Lower stool	a_i	-0.30	-1.00	0.00	0.00	$a_i (y /B) + b_i$
		b_i	0.90	0.25	0.00	1.00	
	Inner hull below $D/2$	a_i	-12.00	-2.40	0.00	1.20	$a_i (z/D) + b_i$
		b_i	5.00	1.00	0.00	0.50	
	Inner hull above $D/2$	a_i	3.00	1.40	0.00	-0.90	$a_i (z/D) + b_i$
		b_i	-2.50	-0.90	0.00	1.55	
	Deck and Upper stool	a_i	0.00	1.00	0.00	0.00	$a_i (y /B) + b_i$
		b_i	1.00	-0.10	0.00	0.00	
	Inner longitudinal bulkhead Below $D/2$	a_i	-1.80	1.90	0.00	0.00	$a_i (z/D) + b_i$
		b_i	1.30	0.00	0.00	0.00	
	Inner longitudinal bulkhead Above $D/2$	a_i	1.80	-2.50	0.00	0.00	$a_i (z/D) + b_i$
		b_i	-0.50	2.20	0.00	0.00	
	Centreline longitudinal bulkhead Below $D/2$	a_i	0.00	0.00	0.00	0.00	$a_i (z/D) + b_i$
		b_i	1.00	0.00	0.00	0.00	
Centreline longitudinal bulkhead Above $D/2$	a_i	0.00	0.00	0.00	0.00	$a_i (z/D) + b_i$	
	b_i	1.00	0.00	0.00	0.00		
Loaded	Bottom shell	a_i	-0.60	-0.15	0.00	0.00	$a_i (y /B) + b_i$
		b_i	-0.45	0.05	1.00	0.00	
	Side shell and bilge below $D/2$	a_i	-1.20	0.18	0.00	0.00	$a_i (z/D) + b_i$
		b_i	0.00	-0.03	1.00	0.00	
	Side shell above $D/2$	a_i	4.00	0.02	0.00	0.00	$a_i (z/D) + b_i$
		b_i	-2.60	0.05	1.00	0.00	
	Inner bottom and Lower stool	a_i	2.80	2.20	0.00	-1.00	$a_i (y /B) + b_i$
		b_i	-0.80	-0.30	0.00	1.10	
	Inner hull below $D/2$	a_i	10.20	1.60	0.00	0.00	$a_i (z/D) + b_i$
		b_i	-4.50	-0.60	0.00	1.00	
	Inner hull above $D/2$	a_i	-0.80	-0.90	0.00	0.00	$a_i (z/D) + b_i$
		b_i	1.00	0.65	0.00	1.00	
	Deck and Upper stool	a_i	-0.24	1.80	0.00	0.00	$a_i (y /B) + b_i$
		b_i	1.00	0.00	0.00	0.00	
	Inner longitudinal bulkhead Below $D/2$	a_i	-2.10	-1.00	0.00	1.50	$a_i (z/D) + b_i$
		b_i	1.15	0.60	0.00	0.35	
	Inner longitudinal bulkhead Above $D/2$	a_i	0.40	-0.30	0.00	-0.40	$a_i (z/D) + b_i$
		b_i	-0.10	0.25	0.00	1.30	
	Centreline longitudinal bulkhead Below $D/2$	a_i	-0.60	0.00	0.00	0.00	$a_i (z/D) + b_i$
		b_i	0.25	0.00	0.00	1.00	
Centreline longitudinal bulkhead Above $D/2$	a_i	0.20	0.00	0.00	0.00	$a_i (z/D) + b_i$	
	b_i	-0.15	0.00	0.00	1.00		

1.4.5 Selection of S-N curves

1.4.5.1 The capacity of welded steel joints with respect to fatigue strength is characterized by S-N curves which give the relationship between the stress ranges applied to a given detail and the number of constant amplitude load cycles to failure.

1.4.5.2 For ship structural details, S-N curves are represented by:

$$S^m N = K_2$$

Where:

- S : stress range, in N/mm^2 , as defined in **1.4.4.19**
- N : predicted number of cycles to failure under stress range S
- m : constant depending on material and weld type, type of loading, geometrical configuration and environmental conditions (air or sea water), as defined in **1.4.5.5**.
- K_2 : constant depending on material and weld type, type of loading, geometrical configuration and environmental conditions (air or sea water), as defined in **1.4.5.5**.

1.4.5.3 Experimental S-N curves are defined by their mean fatigue life and standard deviation. The mean S-N curve gives the stress level S at which the structural detail will fail with a probability level of 50 percent after N loading cycles. S-N curves considered in the present Rules are based upon a statistical analysis of appropriate experimental data and represent two standard deviations below the mean lines.

1.4.5.4 Unless direct experimental measurements are available, the S-N curves described in **1.4.5.5** to **1.4.5.16** are to be used for assessment of the fatigue strength of structural details.

1.4.5.5 As shown in **Fig. C.1.9**, the basic design curves consist of linear relationships between $\log(S)$ and $\log(N)$, which are to be expressed as follows. The S-N curves have a change of inverse slope from m to $m + 2$ at $N = 10^7$ cycles (which corresponds to stress range S_q).

$$\log(N) = \log(K_2) - m \log(S)$$

Where:

- $\log(K_2) = \log(K_1) - 2\delta$
- N : predicted number of cycles to failure under stress range S
- K_1 : constant relating to the mean S-N curve, as given in **Table C.1.6**
- δ : standard deviation of $\log(N)$
- m : inverse slope of the S-N curve, as given in **Table C.1.6**
- S_q : Stress range corresponding to 10^7 cycles of the S-N curve, in N/mm^2 , as given in **Table C.1.6**

Table C.1.6 Basic S-N Curve Data, In-Air

Class	K_1			m	Standard Deviation		K_2	S_q (N/mm^2)
		\log_{10}	\log_e		\log_{10}	\log_e		
B	2.343 E15	15.3697	35.3900	4.0	0.1821	0.4194	1.01E15	100.2
C	1.082 E14	14.0342	32.3153	3.5	0.2041	0.4700	4.23E13	78.2
D	3.988 E12	12.6007	29.0144	3.0	0.2095	0.4824	1.52E12	53.4
E	3.289 E12	12.5169	28.8216	3.0	0.2509	0.5777	1.04E12	47.0
F	1.726 E12	12.2370	28.1770	3.0	0.2183	0.5027	0.63E12	39.8
F ₂	1.231 E12	12.0900	27.8387	3.0	0.2279	0.5248	0.43E12	35.0
G	0.566E12	11.7525	27.0614	3.0	0.1793	0.4129	0.25E12	29.2
W	0.368 E12	11.5662	26.6324	3.0	0.1846	0.4251	0.16E12	25.2

Fig. C.1.9 Basic design S-N curves, In-Air

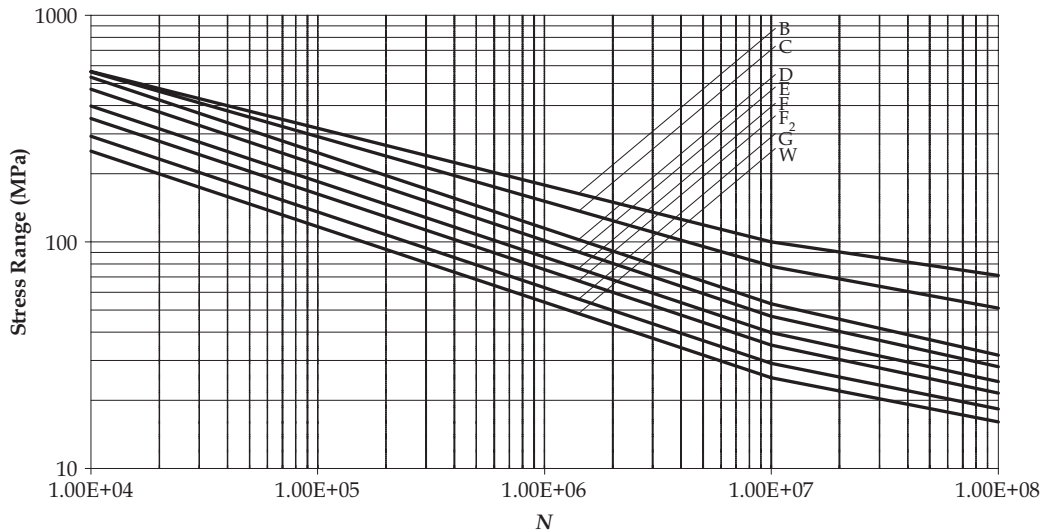

1.4.5.6 The class of S-N curve selected for determination of the cumulative fatigue damage, DM , is to be consistent with the fatigue assessment methods used and the type of detail to be analyzed.

1.4.5.7 Experimental S-N curves give the relationship between the nominal stress range and the number of cycles to failure. Therefore, when using these S-N curves, the calculated stresses are to correspond to the nominal stresses used in creating these curves.

1.4.5.8 The basic S-N curves to be used in this Appendix for fatigue assessment of longitudinal stiffener end connections are given in **1.4.5.5**, with the S-N curve parameters given in **Table C.1.6**.

1.4.5.9 Generally, adjustments to the S-N curves to take into account the following can be made:

- a) effect of mean stresses
- b) effect of plate thickness
- c) weld improvement
- d) influence of the environment.

1.4.5.10 The stress range may be reduced depending on whether the mean stress is tensile or compressive. In the event that it can be demonstrated that a compressive stress exists and can be quantified, the effect of mean stress may be considered by assuming a stress range equal to the tensile component plus 60% of the compressive component. The actual still water bending moment (SWBM) and the applicable static sea and tank pressures for the full load condition or ballast condition as appropriate are to be used in determining the mean stress level.

1.4.5.11 The total stress range considering the mean stress effect is to be taken as follows:

$$\begin{aligned}
 S_{Ri} &= \sigma_{tensile} - 0.6 \sigma_{compressive} && \text{if } \sigma_{compressive} < 0 \text{ and } \sigma_{tensile} > 0 \\
 S_{Ri} &= S && \text{if } \sigma_{compressive} \geq 0 \\
 S_{Ri} &= 0.6S && \text{if } \sigma_{tensile} \leq 0
 \end{aligned}$$

Where:

- $\sigma_{tensile}$: mean stress plus half stress range, in N/mm^2
 $= \sigma_{mean} + S/2$
- $\sigma_{compressive}$: mean stress minus half stress range, in N/mm^2
 $= \sigma_{mean} - S/2$
- σ_{mean} : mean stress due to static load components in the full load condition or ballast condition as appropriate, in N/mm^2 , see **1.3.2**

For the nominal stress approach, S and σ_{mean} are to be calculated as follows:

- S : total combined stress range, in N/mm^2 , as defined in **1.4.4.19**
 $= \sigma_{tensile} - \sigma_{compressive}$
- σ_{mean} : mean stress due to hull girder bending, to be derived using σ_v from **1.4.4.6** with $M_{wv-v-amp}$ taken as the actual SWBM for the
- σ_{hg} : mean stress due to hull girder bending, to be derived using σ_v from **1.4.4.6** with $M_{wv-v-amp}$ taken as the actual SWBM for the

σ_{ex}	: full load condition or ballast condition as appropriate, see 1.3.2 . : mean local bending stress due to external static sea pressure, if applicable. σ_{ex} is to be derived using σ_{2A} from 1.4.4.11 with P calculated based on the actual draught for the full load condition or ballast condition as appropriate, see 1.3.2 , where $P = P_{hys}$, see Section 7/2.2.2.1 .
σ_{in}	: mean local bending stress due to internal static tank pressure, if applicable. σ_{in} is to be derived using σ_{2A} from 1.4.4.11 with P calculated based on the head to the top of tank and the tank contents for the full load condition or ballast condition as appropriate, see 1.3.2 , where $P = P_{in-tk}$, see Section 7/2.2.3.1 .

Notes:

1. P is to be taken as negative when the pressure is acting on the plate side and positive when acting on the stiffener side. This gives compressive stress with a negative sign
2. Where the stiffener is on the boundary between two cargo tanks, then the mean stress is to be taken as the net stress acting on the stiffener.
3. It is to be assumed that water ballast and cargo tanks are 100% full. The fluid density is to be taken in accordance with **Section 7/2.2.3.1**, where cargo density is not to be less than 0.9 tonnes/m^3

For the hot spot stress approach in **Sub-Section 2**, the mean stress, σ_{means} is to be calculated by applying the applicable static loads to the FE model for the full load condition or ballast condition as appropriate. Alternatively, in lieu of applying the static loads to the FE model, the total stress range is to be calculated in accordance with **2.4.2.8**.

1.4.5.12 The fatigue performance of a structural detail depends on member thickness. For the same stress range the joint's fatigue resistance may decrease as the member thickness increases. This effect (also called the 'scale effect') is caused by the local geometry of the weld toe in relation to the thickness of the adjoining plates and the stress gradient over the thickness. The basic design S-N curves are applicable to thicknesses that do not exceed the reference thickness of 22mm . For members with thickness greater than 22mm , the S-N curve for a joint member, with net thickness, t_{net50} , in mm , is to be taken as:

$$\log(N) = \log(K_2) - m \log\left(\frac{S_{Ri}}{(22/t_{net50})^{0.25}}\right)$$

Where:

$\log(K_2)$	= $\log(K_1) - 2\delta$
N	: the predicted number of cycles to failure under stress range S
K_1	: constant relating to the mean S-N curve, as given in Table C.1.6
δ	: standard deviation of $\log(N)$
m	: inverse slope of the S-N curve, as given in Table C.1.6
S_{Ri}	: stress range, as defined in 1.4.5.11 , in N/mm^2

1.4.5.13 Where the longitudinal stiffeners are flat bars or bulb plates, the thickness effect described in **1.4.5.12** is not applicable.

1.4.5.14 The benefits of weld toe grinding should not be taken into consideration at the design stage. However, an exception may be made for the weld connection between the hopper plate and inner bottom if the calculated fatigue life is greater than one half of the design fatigue life or minimum 17 years excluding the grinding effects, whichever is greater. Where grinding is applied, full details of the grinding standard including the extent, smoothness particulars, final weld profile, and grinding workmanship and quality acceptance criteria are to be clearly shown on the applicable drawings and submitted for review together with supporting calculations indicating the proposed factor on the calculated fatigue life. Grinding is preferably to be carried out by rotary burr and to extend below the plate surface in order to remove toe defects and the ground area is to have effective corrosion protection. The treatment is to produce a smooth concave profile at the weld toe with the depth of the depression penetrating into the plate surface to at least 0.5mm below the bottom of any visible undercut. The depth of groove produced is to be kept to a minimum, and, in general, kept to a maximum of 1mm . In no circumstances is the grinding depth to exceed 2mm or 7% of the

plate gross thickness, whichever is smaller. Grinding has to extend to areas well outside the highest stress region. Provided these recommendations are followed, an improvement in fatigue life up to the design fatigue life will be granted.

1.4.5.15 The basic design S-N curves, as shown in **Fig. C.1.9**, are valid for joints located in air or details exposed to sea water but adequately protected from corrosion by effective coating. For unprotected joints in sea water, the basic S-N curves are to be reduced by a factor of 2 on fatigue life.

1.4.5.16 The basic design S-N curves, as shown in **Fig. C.1.9**, are used in this Appendix. To account for the fact that the joint will spend part of the time in a protected environment and part of time in an unprotected environment, a factor f_{SN} , has been introduced into the total nominal stress range calculation.

1.5 Classification of Structural Details

1.5.1 General

1.5.1.1 The joint classification of structural details is to be made using **Table C.1.7** where the design of soft toes and backing brackets corresponds to those shown in **Fig. C.1.10**. When alternative designs are proposed, the adequacy in terms of fatigue strength is to be demonstrated using a suitable finite element analysis. See **2.1.1.3**.

1.5.1.2 Where the primary support member web stiffeners are omitted or not connected to the longitudinals in way of bottom, side and inner hull, see **Note 6 of Table C.1.7**.

Table C.1.7 Classification of Structural Details

Notes			
<p>1. Where the attachment length is less than or equal to 150mm, the S-N curve may be upgraded one class from those specified in the table. For example, if the class shown in the table is <i>F2</i>, upgrade to <i>F</i>. Attachment length is defined as the length of the weld attachment on the longitudinal stiffener face plate without deduction of scallop.</p> <p>2. Where the longitudinal stiffener is a flat bar and there is a stiffener/bracket welded to the face, the S-N curve is to be downgraded by one class from those specified in the table. For example, if the class shown in the table is <i>F</i>, downgrade to <i>F2</i>; if the class shown in the table is <i>F2</i>, downgrade to <i>G</i>. This also applies to unsymmetrical profiles where there is less than 8mm clearance between the edge of the stiffener flange and the face of the attachment, e.g. bulb or angle profiles where the stated clearance cannot be achieved.</p> <p>3. Lapped connections (attachments welded to the web of the longitudinals) should not be adopted and therefore these are not covered by the table.</p> <p>4. For connections fitted with a soft heel, class <i>F</i> may be used if it is predominantly subjected to axial loading. Stiffeners fitted on deck and within 0.1<i>D</i> below deck at side are considered to satisfy this condition.</p> <p>5. For connections fitted with a collar around the face plate (i.e., connection type ID25 through 30) or a full collar (i.e., connection type ID31), class <i>F</i> may be used if subjected to axial loading. Stiffeners fitted on deck and within 0.1<i>D</i> below deck at side are considered to satisfy this condition</p> <p>6. ID31 and 32 show details where web stiffeners are omitted or are not connected to the longitudinal stiffener face plate. A full collar (i.e. connection type ID 31) or alternatively a detail design for cut-outs as shown in Fig. C.1.11 or equivalent is required in way of:</p> <ul style="list-style-type: none"> · Side below the highest point of the wave wetted zone or below 0.1<i>D</i> from the deck at side, whichever is lower. · Bottom · Inner hull longitudinal bulkhead below 0.1<i>D</i> from the deck at side · Hopper · Inner bottom <p>The highest point of the wave wetted zone is defined as the full load draft plus h_{WL} as shown in Fig. C.1.1. Equivalence to Fig. C.1.11 is to be demonstrated through a satisfactory fatigue assessment by using comparative FEM based hot spot stress of the cut-out in the primary support member and the collar.</p> <p>7. For connection type ID32 having no collar welded to the face plate, class <i>F</i> is to be used in way of longitudinals in the strength deck irrespective of slot configuration. In other areas class <i>E</i> may be used irrespective of slot configuration.</p>			
ID	Connection type	Critical Locations Notes (1), (2), (3)	
		A	B
1		F2	F2

Table C.1.7 (Continued) Classification of Structural Details

ID	Connection type	Critical Locations Notes (1), (2), (3)	
		A	B
2		F2	F2(4)
3		F	F2
4		F	F2(4)
5		F	F

Table C.1.7 (Continued) Classification of Structural Details

ID	Connection type	Critical Locations Notes (1), (2), (3)	
		A	B
6		F2	F2(4)
7		F2	F2
8		F2	F2
9		F2	F

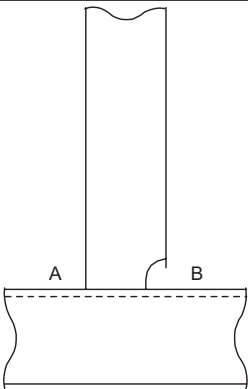
Table C.1.7 (Continued) Classification of Structural Details

ID	Connection type	Critical Locations Notes (1), (2), (3)	
		A	B
10		F2	F2
11		F	F2
12		F2	F
13		F2	F2

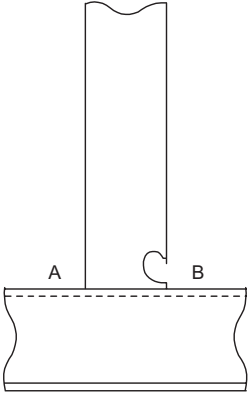
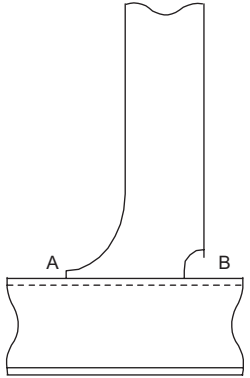
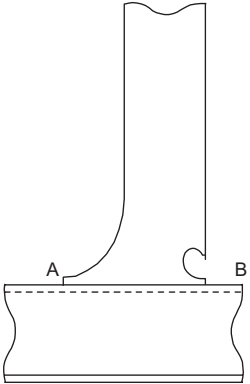
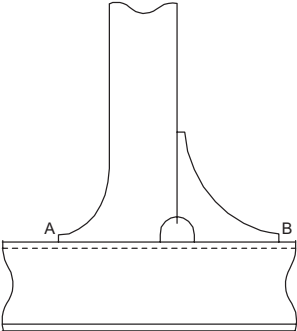
Table C.1.7 (Continued) Classification of Structural Details

ID	Connection type	Critical Locations Notes (1), (2), (3)	
		A	B
14		F2	F2(4)
15		F2	F2
16		F2	F
17		F	F2

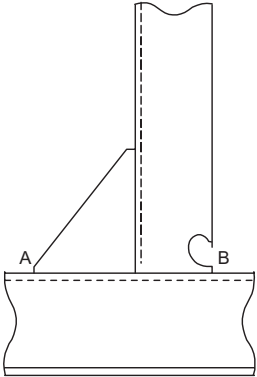
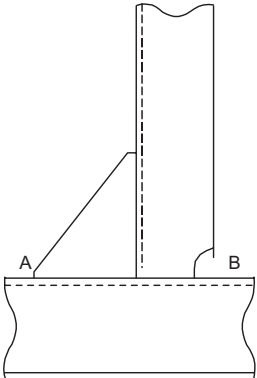
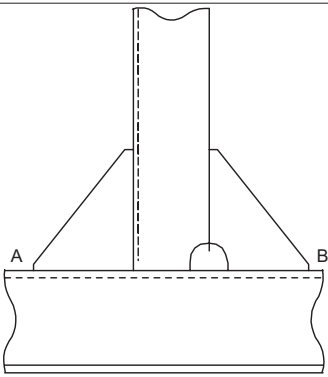
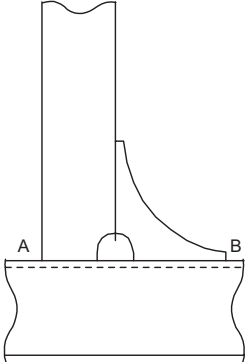
Table C.1.7 (Continued) Classification of Structural Details

ID	Connection type	Critical Locations Notes (1), (2), (3)	
		A	B
18		F	F2(4)
19		F	F
20		F	F2
21		F	F2

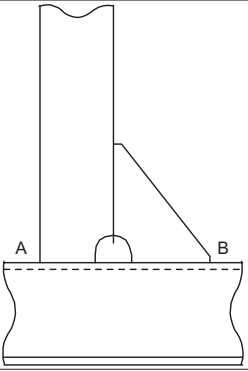
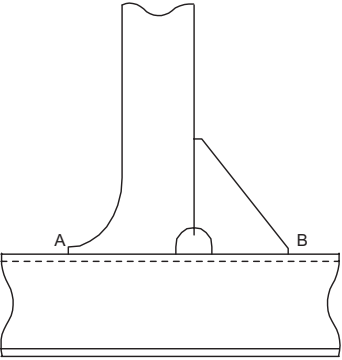
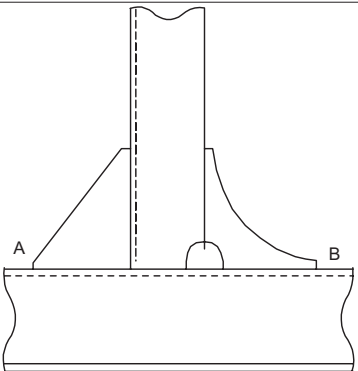
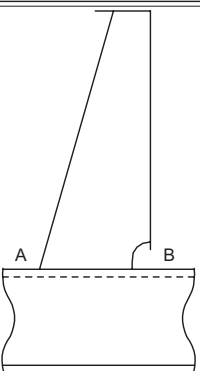
Table C.1.7 (Continued) Classification of Structural Details

ID	Connection type	Critical Locations Notes (1), (2), (3)	
		A	B
22		F	F2(4)
23		F	F
24		F	F2
25		F2	F2(5 only)

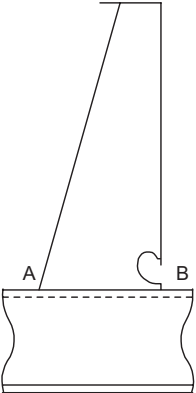
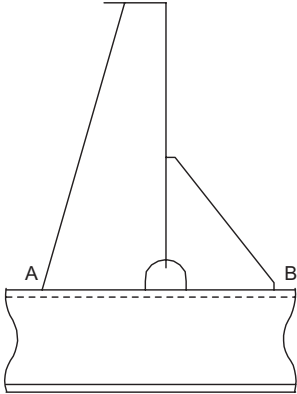
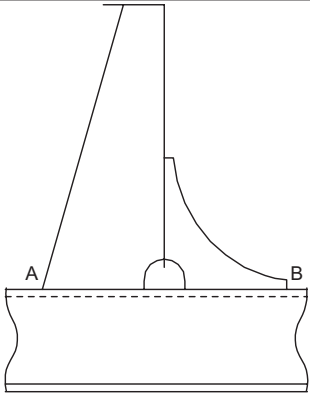
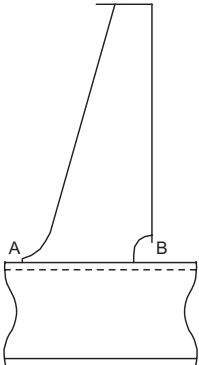
Table C.1.7 (Continued) Classification of Structural Details

ID	Connection type	Critical Locations Notes (1), (2), (3)	
		A	B
26		F	F2(5 only)
27		F2	F2(5 only)
28		F2	F2(5 only)
29		F	F2(5 only)

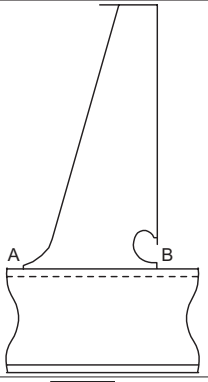
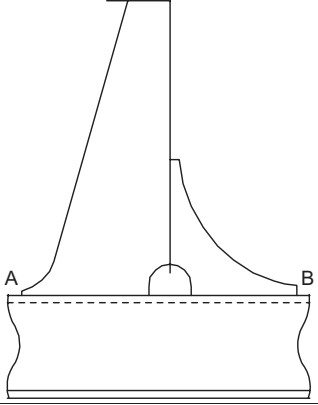
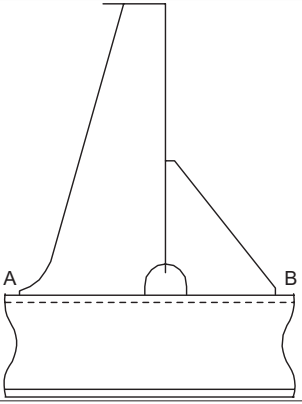
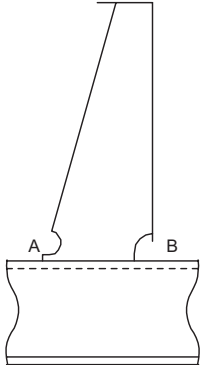
Table C.1.7 (Continued) Classification of Structural Details

ID	Connection type	Critical Locations Notes (1), (2), (3)	
		A	B
30		F	F2(5 only)
31		F2(5, 6 only)	F2(5, 6 only)
32		F(6, 7 only)	N/A

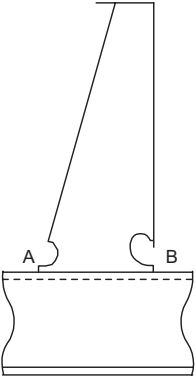
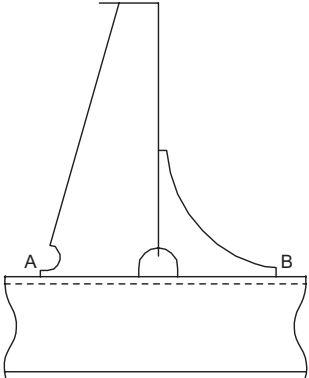
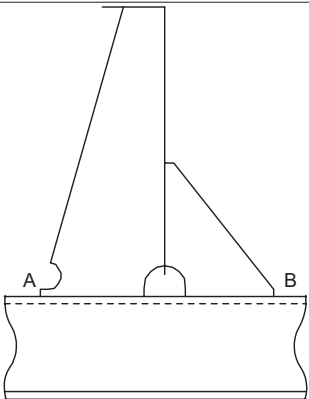
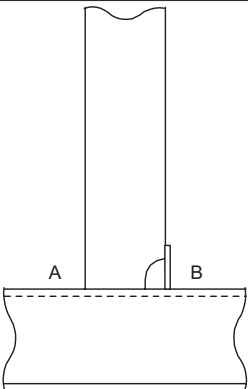
Fig. C.1.10 Detail Design for Soft Toes and Backing Brackets



Recommended Design of Soft Toes and Backing Bracket of Pillar Stiffeners

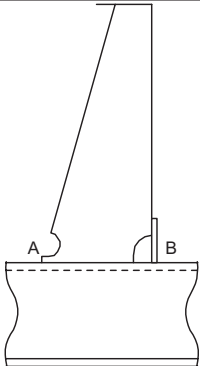
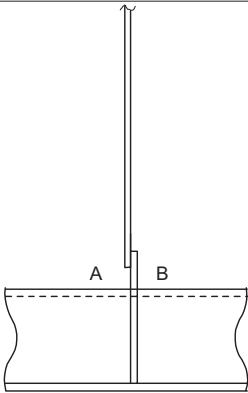
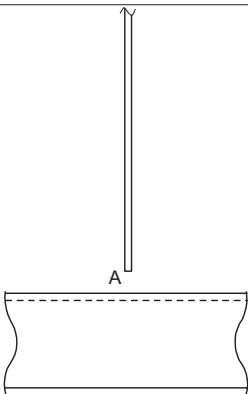
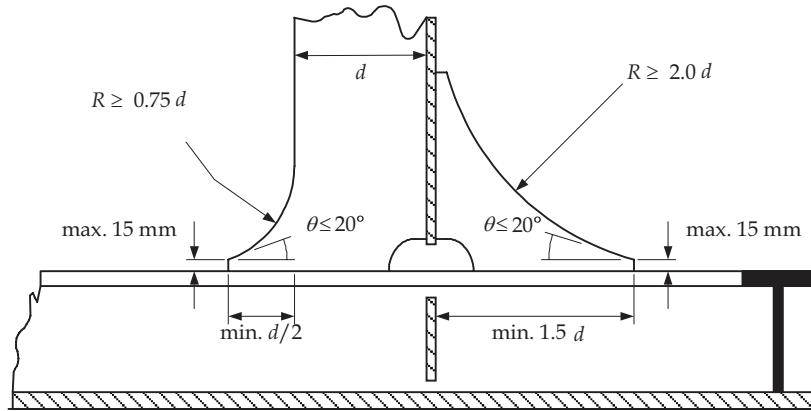
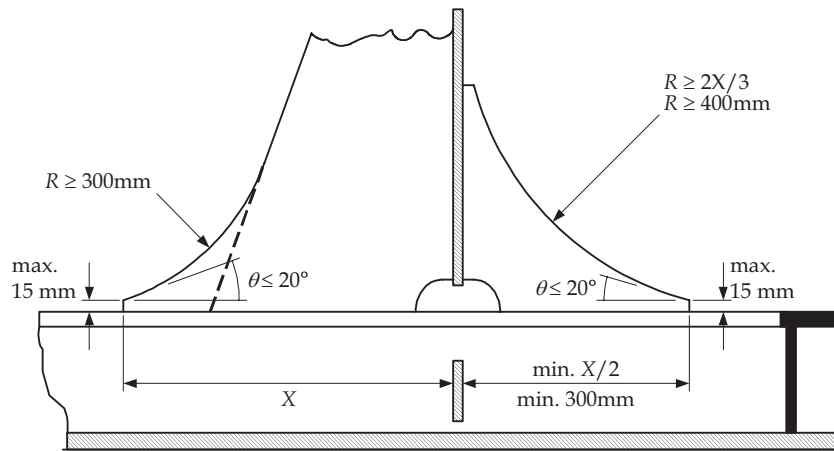

Recommended Design of Soft Toes and Backing Bracket of Tripping Brackets

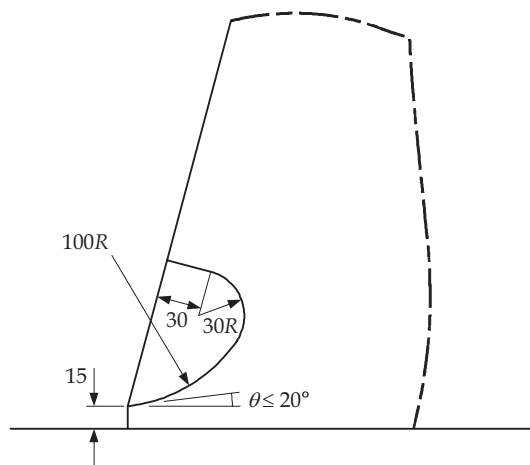

Recommended Alternative Design of Soft Toes of Tripping Brackets

Fig. C.1.11 Design for Cut Outs

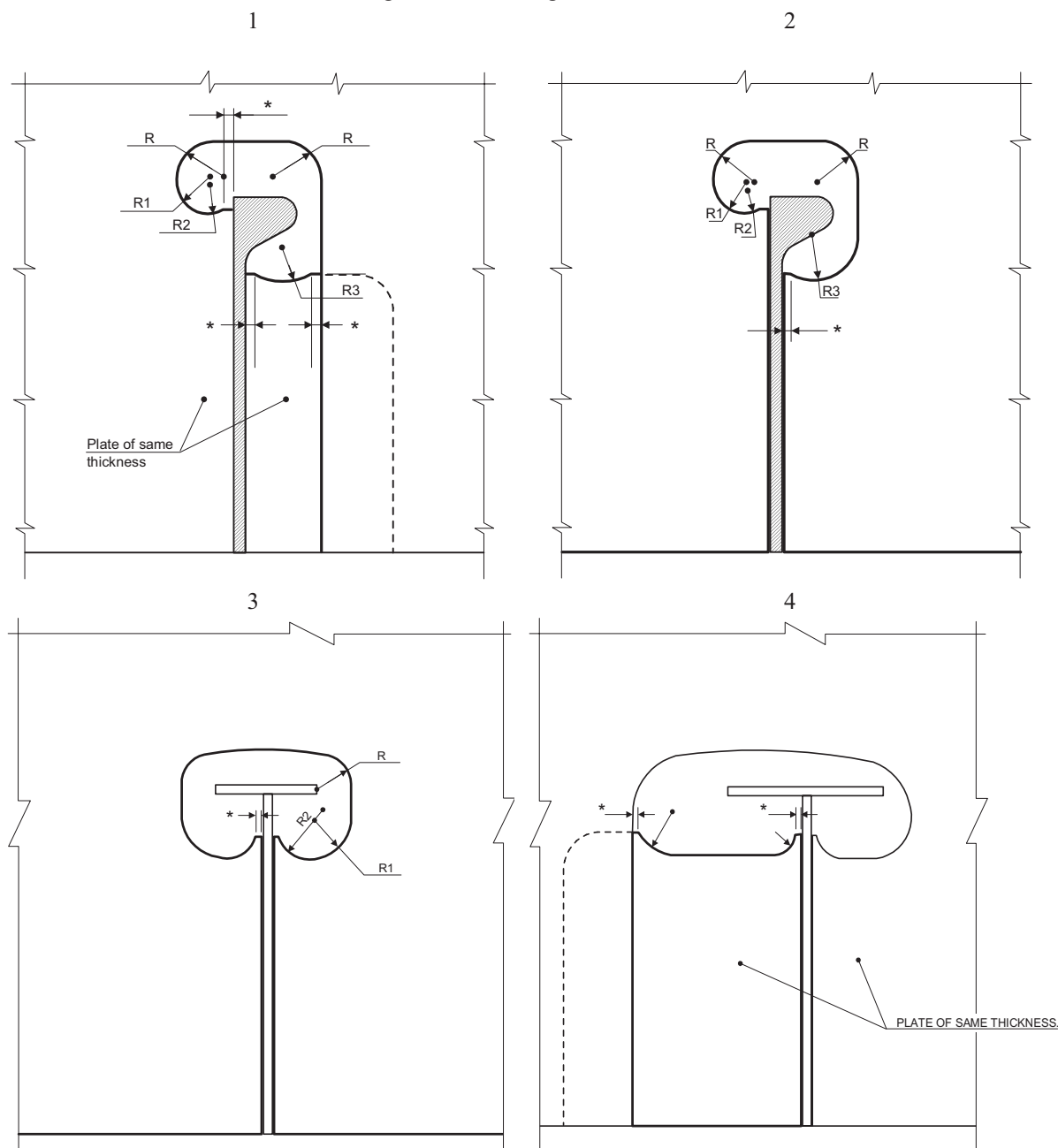

Notes:

1. Soft toes marked “*” are to be dimensioned to suit the weld leg length such that smooth transition from the weld to the radiused part can be achieved. Max. 15 mm.
2. Configurations 1 and 4 indicate acceptable lapped lug plate connections, alternatively, butted lug plates with similar shape may be adopted.
3. Designs that are different than shown in the above sketches are acceptable subject to a satisfactory fatigue assessment by using comparative FEM based hot spot stress.

1.6 Other Details

1.6.1 Scallop in way of block joints

1.6.1.1 Scallop in way of block joints in the cargo tank region, located on the strength deck, and down to $0.1D$ from the deck at side are to be designed according to **Fig. C.1.12** unless the specification in **Section 8/1.5.1.3** for class F2 is satisfied.

Fig. C.1.12 Welding of Deck Stiffeners in way of Block Joints

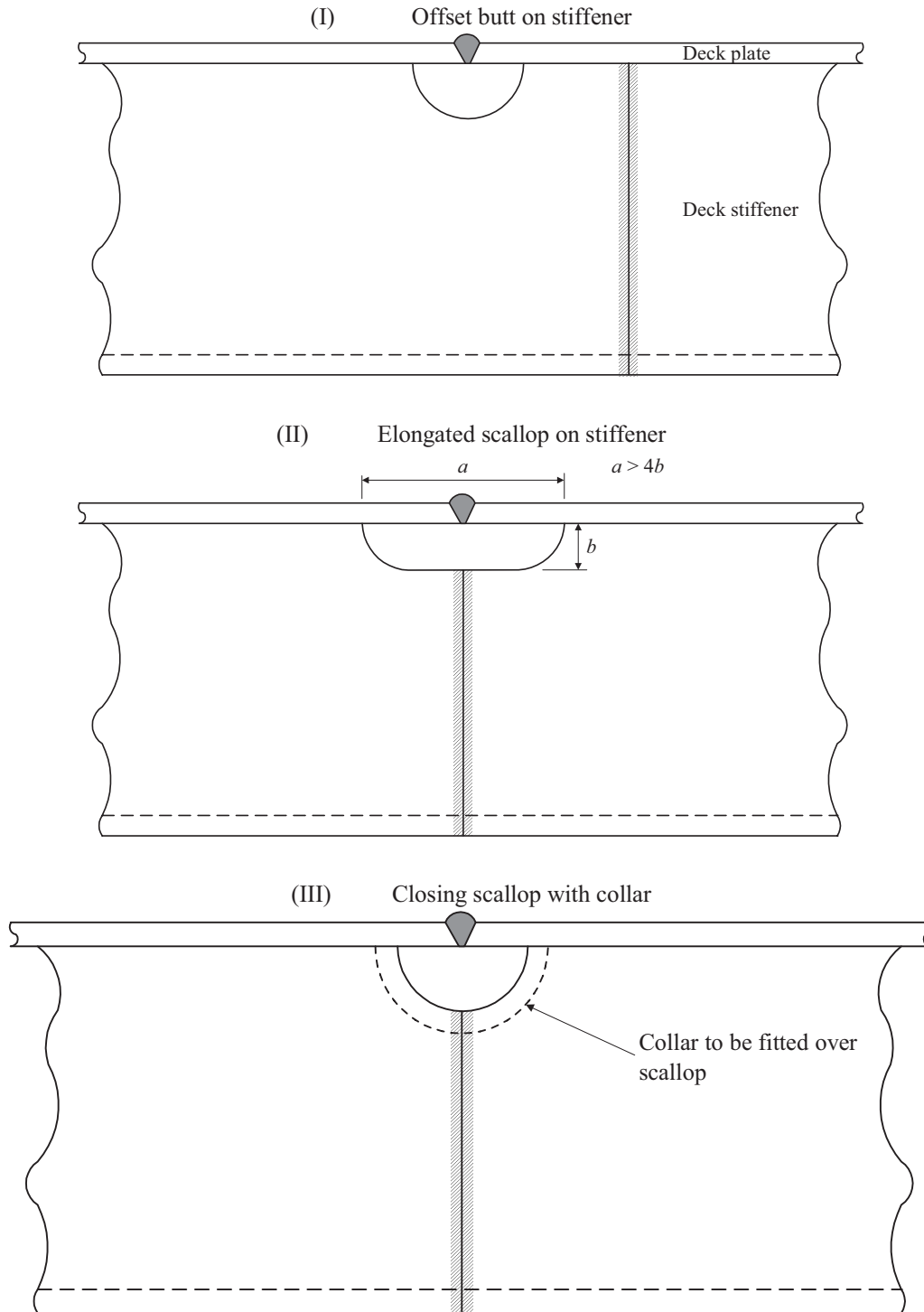

Notes:

Alternative scallop geometry to that shown in option II may be accepted subject to demonstration of satisfactory fatigue life based on hull girder loads taking into account additional stress concentration factor in way of weld, determined using fine mesh FEM and applying class D S-N curve.

2. Hot Spot Stress (FE Based) Approach

2.1 General

2.1.1 Applicability

2.1.1.1 The procedure in this section applies to welded knuckles between inner bottom and hopper plate fatigue analysis using a finite element (FE) based hot spot stress approach. A similar application method as described in **Sub-Section 1** for the nominal stress approach is used except where indicated in the following sections.

2.1.1.2 Where the hopper knuckle between inner bottom and hopper plate is of the bent type, hot spot stress fatigue assessment is not a requirement provided the detail design standard described in **2.5.1.2** is followed. When alternative design is proposed, a suitable finite element (FE) analysis should be used to demonstrate the equivalency of the detail in terms of fatigue strength.

2.1.1.3 Where the hot spot stress approach is considered necessary for demonstration of the adequacy of longitudinal stiffener end connection in lieu of the nominal stress approach, the procedure described in **Sub-Section 1** is generally to be followed with the exception that S_v , S_h , S_i , and S_e are to be determined directly from the finite element analysis using the surface hot spot stress component perpendicular to the weld obtained by linear extrapolation to the centre-line of the attachment, and then to the weld toe position. The S-N curve according to **2.4.3** is applicable.

2.1.2 Assumptions

2.1.2.1 The assumptions made are given in **1.1.2**.

2.2. Corrosion Model

2.2.1 Net thickness

2.2.1.1 The net thickness and corrosion additions given in **Section 6/3** are to be incorporated into the representation of the FE structural capacity models as described in **Appendix B/4**.

2.3 Loads

2.3.1 General

2.3.1.1 Dynamic wave and tank pressures are to be considered for the FE based fatigue analysis of knuckles between inner bottom and hopper plates, see **1.3.6** and **1.3.7**.

2.4. Fatigue Damage Calculation

2.4.1 Fatigue strength determination

2.4.1.1 The procedure outlined in **1.4** is to be applied.

2.4.1.2 The Weibull probability distribution parameter applicable to welded knuckles between inner bottom and hopper plate, ξ , is to be taken as:

$$\xi = 1.1 - 0.35 \frac{L_{CSR-T} - 100}{300}$$

Where:

L_{CSR-T} : rule length, in m , as defined in **Section 4/1.1.1.1**

2.4.2 Stresses to be used

2.4.2.1 To determine hot spot stresses, local 2D or 3D very fine mesh stress analyses, in conjunction with a 3D coarse mesh analysis are to be used. In highly stressed areas, in particular in the vicinity of structural discontinuities, the level of stresses depends on the size of elements because of the high stress gradient. If the stress field is more complex than a uniaxial field, the stresses adjacent to the potential crack location are to be used. A uniform mesh is to be used with smooth transition and avoidance of abrupt changes in mesh size.

2.4.2.2 The following defines a general basis for the modelling of local structures:

- (a) hot spot stresses are to be calculated using an idealized welded joint with no misalignments. The finite element mesh is to be fine enough near the hot spot such that stresses and stress gradients can be determined with sufficient accuracy
- (b) plating, webs and face plates of primary and secondary members are modelled by 4-node thin shell elements. In cases of steep stress gradients, 8-node thin shell elements are to be used.
- (c) when thin shell elements are used, the structure is to be modelled at the mid face of the plates. For practical purposes, adjoining plates of different thickness may be assumed to be median line aligned, i.e., no staggering in way of thickness change is required.
- (d) the aspect ratio of elements is not to be greater than three in the vicinity of the hot spot.
- (e) the size of elements located in the vicinity of the hot spot is to be comparative to the net thickness of the structural member
- (f) stresses are to be calculated at the surface of the plate with a view to taking into account the plate bending moment, where relevant.

2.4.2.3 A detailed description of hot spot stress calculation using finite element modelling is given by **Appendix B/4**.

2.4.2.4 Generally, the element stresses are derived at the Gaussian integration points. Depending on the element type, it may be necessary to perform several interpolations in order to determine the actual stress at the considered hot spot location.

2.4.2.5 For critical structural details, hot spot stresses are generally highly dependent on the finite element model used for representation of the structure. Alternative procedures to those described here, for the derivation of the hot spot stress, are to be confirmed or documented by reference to available fatigue test results for similar structural details.

2.4.2.6 The hot spot stress is defined as the surface stress at $0.5t$ away from the weld toe location, as shown in **Fig. C.2.1**.

C.2.1. The hot spot stress is to be obtained by linear interpolation in the ship's transverse direction using the respective stress at the 1st and 2nd element from the structure intersection.

Fig. C.2.1 Hot Spot Stress

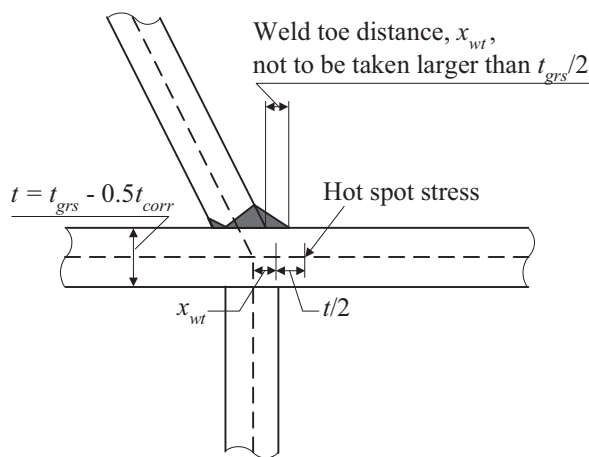

2.4.2.7 Stress range components along the direction perpendicular to the weld, due to the loads defined in 2.3, are to be calculated based on **Appendix B/4**. The total combined stress range, S , is to be taken as:

$$S = f_{model} \left| 0.85(S_{e1} + 0.25S_{e2}) - 0.3S_i \right| \quad \text{for full load condition}$$

$$S = f_{model} \left| 0.85(S_{e1} - 0.2S_{e2}) \right| \quad \text{for ballast load condition}$$

Where:

- S_{e1} : stress range due to dynamic wave pressure applied to FE-model on the side where the hopper knuckle is to be investigated, in N/mm^2 , see **Table B.4.1**
- S_{e2} : stress range due to dynamic wave pressure applied to FE-model on

	the side of the hull where the hopper knuckle is not analysed, in N/mm^2 , see Table B.4.1
S_i	: stress range due to dynamic tank pressure applied to FE-model, in N/mm^2 , see Appendix B/4.5.2.4 and Table B.4.1
f_{model}	: 1.0 if the FE model is made according to net thickness for fatigue, i.e. using corrosion addition of $0.25t_{corr}$ for the FE model except in way of critical location (in way of a knuckle and within 500mm in all directions), which uses corrosion addition of $0.5t_{corr}$ 0.95 if the FE model for strength assessment is used. FE model for strength assessment applies a corrosion addition of $0.5t_{corr}$ for the whole model including structure in way of critical location

2.4.2.8 To account for the mean stress effect, in lieu of applying the static loads to the FE model, the total stress range may be taken as:

$$S_{Ri} = 1.0S \quad \text{for full load condition}$$

$$S_{Ri} = 0.6S \quad \text{for ballast load condition}$$

Where:

S : total combined stress range, in N/mm^2 , as defined in **2.4.2.7**

2.4.3 Selection of S-N curves

2.4.3.1 The fatigue analysis is to be carried out applying the Class D S-N curve for welded details if the hot spot stress is calculated according to **2.4.2.8**. The thickness effect according to **1.4.5.12** will be applicable.

2.5 Detail Design Standard

2.5.1 Hopper knuckles

2.5.1.1 Design details for the welded knuckle between hopper plating and inner bottom plating are to be as shown in **Fig. C.2.2**.

Guidance Note:

Fig. C.2.3 may be used as an option to increase fatigue strength at the hopper connection.

2.5.1.2 Design details for the bent knuckle between hopper plating and inner bottom plating are to be as shown in **Fig. C.2.4**.

2.5.2 Transverse Bulkhead Horizontal Stringer Heel

2.5.2.1 Detail design improvement given in **Fig. C.2.5** is recommended for reducing the stress level and increasing fatigue strength at the horizontal stringer heel location between transverse oil-tight and wash bulkhead plating and inner hull longitudinal bulkhead plating. This recommendation should be considered in association with fine mesh FE analysis as required in **Appendix B/3.1.3**.

Fig. C.2.2 Hopper Knuckle Connection Detail, Without Bracket

Connections of floors in double bottom tanks to hopper tanks Hopper corner connections employing welded inner bottom and hopper sloping plating	
CRITICAL AREAS	DETAIL DESIGN STANDARD A
	
CRITICAL LOCATIONS	
 <p style="text-align: center;">Section A-A</p>	 <p style="text-align: center;">Section B-B</p> <p>Weld between hopper plating and inner bottom plating to be extended and ground smooth. Visible undercuts are to be removed. Weld extension and grinding to be applied 200 mm either side of the floor.</p> <p>Notes:</p> <ol style="list-style-type: none"> 1. A root face with a maximum of 1/3 of the abutting plate thickness is acceptable for the partial penetration welding, see Section 6/5.3.4. 2. Grinding need not be applied in the No.1 tank in which floor spans are reduced due to shape. 3. Grinding need not be applied for the knuckle joints at transverse bulkhead positions, or at the floor adjacent to the transverse bulkhead.
Minimum Requirement	As a minimum, detail design standard A or B is to be fitted. Further consideration will be given where the hopper angle exceeds 50 degrees. The ground surface is to be protected by a stripe coat, of suitable paint composition, where the lower hopper knuckle region of cargo tanks is not coated.
Critical Location	Hopper sloping plating connections to inner bottom plating in way of floors. Floor connections to inner bottom plating and side girders in way of hopper corners.
Detail Design Standard	Elimination of scallops in way of hopper corners, extension of inner bottom plating to reduce level of resultant stresses arising from cyclic external hydrodynamic pressure, cargo inertia pressure and hull girder loads. Scarfing bracket thickness is to be close to that of the inner bottom in way of knuckle.
Building Tolerances	Median line of hopper sloping plate is to be in line with the median line of the girder with an allowable tolerance of $t/3$ or 5mm, whichever is less, where t is the inner bottom thickness. The allowable tolerance is to be measured parallel to the inner bottom.
Welding Requirements	Partial penetration welding (hopper sloping plating to inner bottom plating). Partial penetration weld (connection of floors to inner bottom plating and to side girders, connection of hopper transverse webs to sloping plating, to inner bottom plating, and to side girders in way of hopper corners).

Fig. C.2.3 Option: Hopper Knuckle Connection Detail, With Bracket

Connections of floors in double bottom tanks to hopper tanks Hopper corner connections employing welded inner bottom and hopper sloping plating	
CRITICAL AREAS	DETAIL DESIGN STANDARD B
	
CRITICAL LOCATIONS	
 <p style="text-align: center;">Section A-A</p>	<p>Notes:</p> <ol style="list-style-type: none"> 1. Bracket to be fitted inside cargo tank 2. Bracket to extend approximately to the first longitudinal 3. The bracket toes are to have a soft nose design 4. Full penetration welding at bracket toes 5. Bracket material to be same as that of inner bottom 6. Buckling of bracket to be checked: $\frac{d}{t_{bkt}} < 21 \sqrt{\frac{235}{\sigma_{yd}}}$ where: d =bracket max depth, as defined in Table 10.2.3 t_{bkt} =bracket thickness σ_{yd} =specified minimum yield stress of material
Minimum Requirement	As a minimum, detail design standard A or B is to be fitted. Further consideration will be given where hopper angle exceeds 50degrees.
Critical Location	Hopper sloping plating connections to inner bottom plating in way of floors. Floor connections to inner bottom plating and side girders in way of hopper corners.
Detail Design Standard	Elimination of scallops in way of hopper corners, extension of inner bottom plating to reduce level of resultant stresses arising from cyclic external hydrodynamic pressure, cargo inertia pressure and hull girder loads. Scarfing bracket thickness to be close to that of the inner bottom in way of knuckle.
Building Tolerances	Median line of hopper sloping plate is to be in line with the median line of the girder with an allowable tolerance of $t/3$ or 5mm, whichever is less, where t is the inner bottom thickness.
Welding Requirements	Partial penetration welding (hopper sloping plating to inner bottom plating). Partial penetration weld (connection of floors to inner bottom plating and to side girders, connection of hopper transverse webs to sloping plating, to inner bottom plating, and to side girders in way of hopper corners).

Fig. C.2.4 Hopper Knuckle Connection Detail, Bent Type

Connections of floors in double bottom tanks to hopper tanks Hopper corner connections employing bent knuckle inner bottom and hopper sloping plating	
CRITICAL AREAS	DETAIL DESIGN STANDARD C
	
CRITICAL LOCATIONS	
 	 <p>Note: Longitudinal brackets may be omitted if it can be demonstrated that the girder provides sufficient support at the knuckle line.</p>
Minimum Requirement	As a minimum, the detail design standard C is to be fitted.
Critical Location	Side girder connections to inner bottom plating in way of floors. Floor and hopper transverse web connections to inner bottom plating and to side girders in way of hopper corners.
Detail Design Standard	Elimination of scallops in way of hopper corners and additional longitudinal brackets to reduce peak and range of resultant stresses arising from cyclic external hydrodynamic pressure, cargo inertia pressure, and hull girder global loading.
Building Tolerances	Enhanced alignment standard. The nominal distance between the centres of thickness of the two abutting members (e.g. floor and hopper web plate and additional supporting brackets) should not exceed 1/3 of the table member thickness.
Welding Requirements	Partial penetration welding with a maximum root face of 1/3 of the abutting plate thickness (Connection of side girders to inner bottom plating. Connection of floors to inner bottom plating and to side girders. Connection of hopper transverse webs to sloped inner bottom plating and to side girders in way of hopper corners).

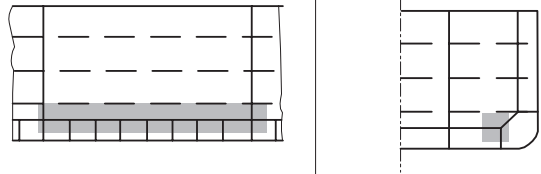
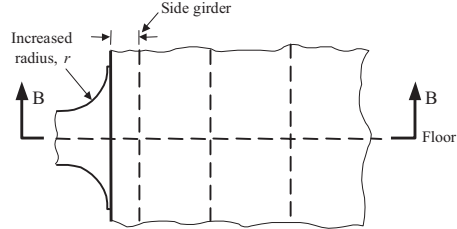
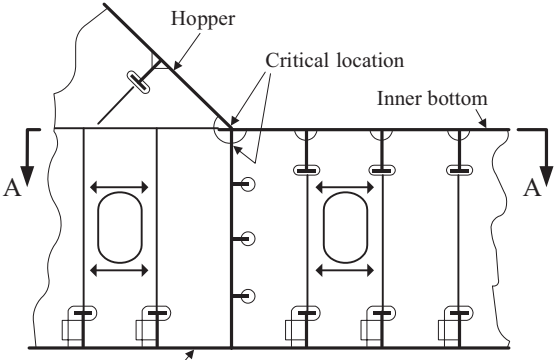
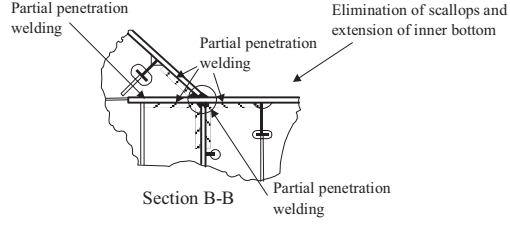
Fig. C.2.5 Option: Transverse Bulkhead Horizontal Stringer Heel

Connections of horizontal girder in double side tanks to transverse bulkheads	
Connection of horizontal stringer on plane oiltight transverse or wash bulkheads to inner hull longitudinal bulkhead	
CRITICAL AREAS	DETAIL DESIGN IMPROVEMENT
	<p>Partial penetration welding where backing bracket not fitted</p> <p>max. 15 mm</p> <p>Edges ground smooth **</p> <p>max. 15 mm</p> <p>Note: * Weld toe to be ground smooth, visible undercuts to be removed where brackets not fitted. ** Where a face plate is considered necessary, it is recommended that design features be adopted to reduce the stress concentration at the face plate termination (e.g., taper and soft nose).</p>
CRITICAL LOCATIONS	
<p>Horizontal girder</p> <p>Horizontal stringer</p> <p>Critical location</p> <p>Inner hull Longitudinal bulkhead</p> <p>Oiltight or wash transverse bulkhead</p> <p>Side shell</p>	
Critical Location	Intersections of webs of transverse bulkhead horizontal stringer and double side tank horizontal girder forming square corners.
Detail Design Improvement	Elimination of scallops in way of cruciform joint and fitting a localized 'D' grade steel insert plate, with minimum thickness of 7 mm in addition to the Rule required thickness, to reduce the peak and range of resultant stresses arising from cyclic cargo inertia pressure and hull girder global loading. In addition, a soft toed backing bracket of suitable dimension is to be fitted. The following bracket sizes are recommended: VLCC: 800×800×30 R600 with soft toe as shown in Figure Suezmax and Aframax tankers: 800×600×25 R550 with soft toe as shown in Figure, where the longer arm length is in way of the inner skin. The actual bracket design is to be verified by fine mesh finite element analysis in accordance with Appendix B/3.1.3 .
Building Tolerances	Enhanced alignment standard. The nominal distance between the centres of thickness of the two abutting members should not exceed 1/3 of the table member thickness.
Welding Requirements	Fillet welding having minimum weld factor of 0.44, where backing bracket is fitted or partial penetration welding where backing bracket is not fitted. The extent of partial penetration should be of the order of longitudinal spacing. A small scallop of suitable shape, which is to be closed by welding after completion of the continuous welding of bulkhead, should be provided where scallop is eliminated.

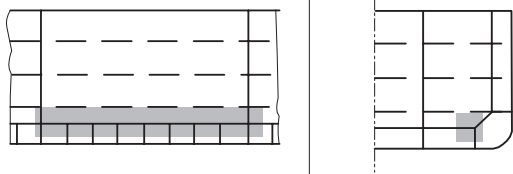
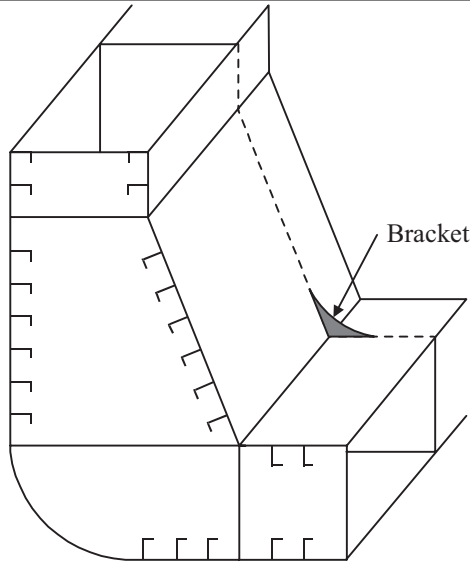
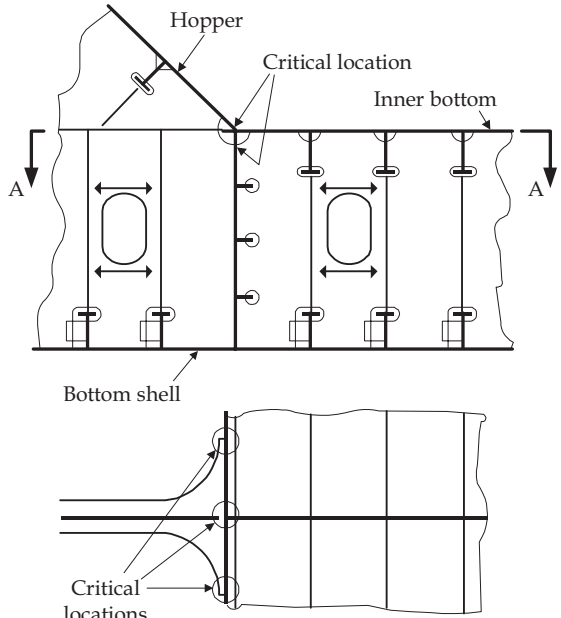
2.5.3 Transverse and longitudinal corrugated bulkhead connection to lower stool

2.5.3.1 Detail design improvement given in **Fig. C.2.6** is recommended for reducing the stress level at the connection of transverse and longitudinal corrugated bulkhead to lower stool. This recommendation should be considered in association with fine mesh FE analysis as required in **Appendix B/3.1.5**.

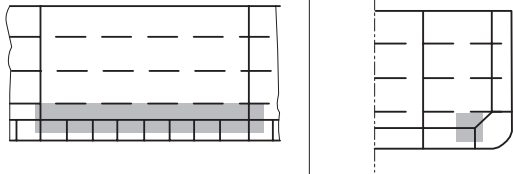
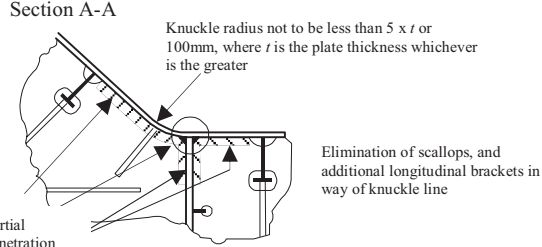
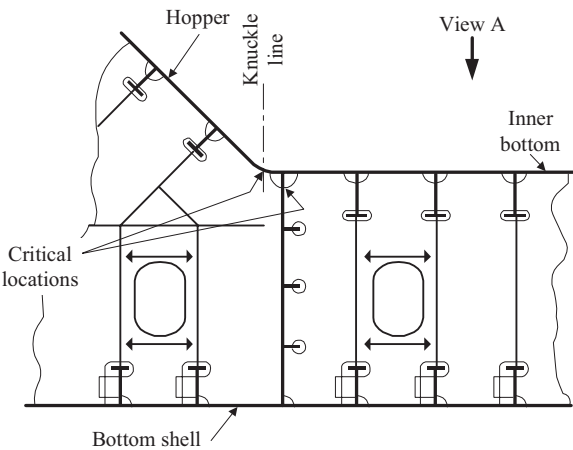
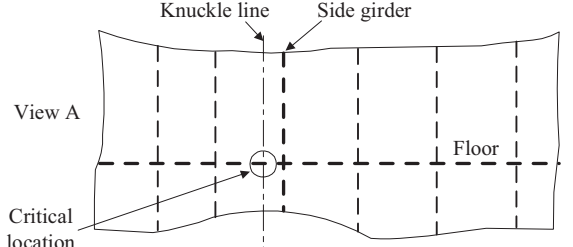
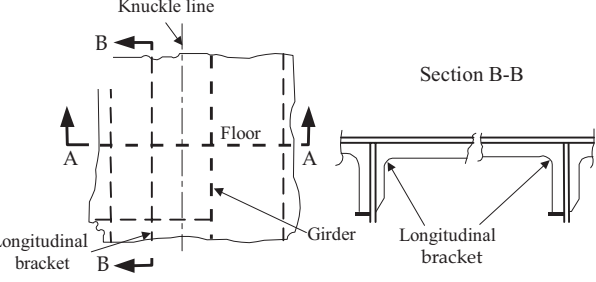
Fig. C.2.6 Transverse and Longitudinal Bulkhead Connection to Lower Stool

Connections of side stringers in double side tanks to transverse bulkheads Higher tensile stringers to horizontal girders on plane oiltight transverse or wash bulkheads	
<p>CRITICAL AREAS</p>	<p>DETAIL DESIGN IMPROVEMENT</p>
<p>CRITICAL LOCATIONS</p> <p style="text-align: center;">Section A-A</p>	<p style="text-align: center;">Section A-A improvement</p>
<p>Note:</p> <ul style="list-style-type: none"> * Full penetration weld is to be applied at the connection of the corrugated bulkhead and stool plate to the shelf plate of the lower stool. ** Where adjacent shedder plates cross, a bracket stiffener is to be provided at the crossing point. 	
<p>Critical Location</p>	<ol style="list-style-type: none"> 1. Connections of corrugated bulkhead to lower stool and shelf plate 2. Connections of corrugated bulkhead to shedder plate if fitted without a gusset plate
<p>Detail Design Improvement</p>	<ol style="list-style-type: none"> 1. Gusset plate should be fitted to the shelf plate in line with the face of the corrugation to reduce stress concentrations at the corrugated corners. The minimum height of the gusset plate should be taken as half the corrugated bulkhead flange width. 2. To reduce stress concentration at the crossing of the shedder plates, shedder plates may be arranged in an alternate configuration as shown in figure. Alternatively, bracketed stiffener may be fitted at the crossing points underneath the shedder plates.
<p>Building Tolerances</p>	<p>Ensure good alignment between lower stool sloping plates and corrugation faces as far as possible. The nominal distance between the centres of thickness of the two abutting members should not exceed 1/3 of the table member thickness.</p>
<p>Welding Requirements</p>	<p>Full penetration welding should be used at the connections of the bulkhead corrugations, gusset plates and the lower stool sloping plates to the lower stool shelf plate (Grade Z steel is recommended). Start and stop of welding should be as far away as practicable from the corners of the corrugations.</p>

Appendix D BUCKLING STRENGTH ASSESSMENT

1. Advanced Buckling Analysis

1.1 General

1.1.1 Scope

1.1.1.1 This appendix describes the advanced buckling analysis method and its application as required by this part. The advanced buckling analysis method is to be based on nonlinear analysis techniques, or equivalent, which predict the complex behaviour of stiffened and un-stiffened panels.

1.1.2 Alternative procedures

1.1.2.1 While this appendix describes the general purpose or direct calculation techniques to be employed, alternative advanced buckling and ultimate strength analysis procedures may be used provided they give comparable and consistent results to those obtained using the reference advanced buckling procedure which is the basis for the permissible buckling utilisation factors in **Section 9/Table 9.2.2**. See also **1.1.2.3**.

1.1.2.2 Where an alternative advanced procedure is used, documentation of the alternative advanced buckling analysis methodologies and detailed comparison of its results with those of the reference advanced buckling procedure and software tools are to be supplied for review and acceptance.

1.1.2.3 Use of alternative buckling procedures to the reference advanced buckling procedure is acceptable provided that the alternative procedure is verified against the test cases specified in the **Background to Appendix D** and where the permissible utilisation buckling factor for the alternative method, $\eta_{all-alt}$, complies with:

$$\eta_{all-alt} \leq \eta_{all} \cdot \left(\frac{\eta_{alt-i}}{\eta_{ref-i}} \right)_{\min}$$

Where:

η_{all}	permissible utilisation factor against buckling for plate and stiffened panels as specified in Section 9/Table 9.2.2
η_{ref-i}	utilisation factor for reference advanced buckling procedure for test case <i>i</i> specified in Background to Appendix D
η_{alt-i}	utilisation factor for alternative buckling procedure for test case <i>i</i> specified in Background to Appendix D

1.1.3 Definitions

1.1.3.1 “Buckling” is used as a generic term to describe the strength of structures, generally under in-plane compressions and/or shear. The buckling strength or capacity can take into account the internal redistribution of loads depending on the situation.

1.1.3.2 Buckling capacity accepting local elastic plate buckling with load redistribution is referred to as Method 1. The buckling capacity is the load that results in the first occurrence of membrane yield stress anywhere in the stiffened panel. Buckling capacity based on this principle gives a lower bound estimate of ultimate capacity, or the maximum load the panel can carry without suffering major permanent set. Method 1 buckling capacity assessment utilizes the positive elastic post-buckling effect for plates and accounts for load redistribution between the structural components, such as between plating and stiffeners. For slender structures the capacity calculated using this method is typically higher than the ideal elastic buckling stress (minimum Eigen-value). Accepting elastic buckling of structural components in slender stiffened panels implies that large elastic deflections and reduced in-plane stiffness will occur at higher buckling utilization levels.

1.1.3.3. Method 2 buckling capacity does not accept load redistribution between structural components and refers to the minimum of value of the ideal elastic buckling stress and the Method 1 buckling capacity. Method 2 buckling capacity normally equals the same strength as Method 1 for stocky panels, while it is the ideal elastic buckling stress (minimum

Eigen-value cut-off) for slender panels. By applying the ideal elastic buckling stress limitation, large elastic deflections and reduced in-plane stiffness will be avoided at higher buckling utilization levels.

1.1.3.4 A “buckling failure mode” refers to a specific pattern of buckling failure. Typical failure modes of stiffened panels with open profiles are:

- (a) plate buckling
- (b) torsional stiffener buckling
- (c) stiffener web plate buckling
- (d) lateral stiffener buckling.

2. Advanced Buckling Analysis Method

2.1 General

2.1.1 Effects to consider

2.1.1.1 The advanced buckling assessment method is to be capable of considering the following effects:

- (a) non linear geometrical behaviour
- (b) inelastic material behaviour
- (c) initial deflections - geometrical imperfections/out-of flatness
- (d) welding residual stresses
- (e) interactions between buckling modes and structural elements; plates, stiffeners, girders etc.
- (f) simultaneous acting loads; bi-axial compression/tension, shear and lateral pressure
- (g) boundary conditions.

2.1.1.2 Detailed requirements for items listed in 2.1.1.1 are given in 2.1.2 to 2.1.8. Additional requirements applicable to non-linear finite element models are given in 2.1.9 and 2.1.10.

2.1.2 Non linear geometrical behaviour

2.1.2.1 The buckling method is to be based on non-linear large deflection plate theory or equivalent. Second order membrane strains due to geometrical non-linearity are to be accounted for.

2.1.2.2 Non-linear plate theory according to von Karman and Marguerre is acceptable for assessing the strength beyond the ideal elastic buckling level.

2.1.3 Material behaviour and properties

2.1.3.1 Inelastic material behaviour is to be considered. If the buckling method is not capable of handling non linear material and spread of plasticity, then the redistributed stress fields due to non-linear geometrical behaviour and geometrical imperfections are to be limited to below the von Mises yield criterion.

2.1.3.2 Alternatively, if the buckling method is capable of handling non linear material, then a bi-linear material model is to be used with a conservative strain-hardening coefficient in the plastic region.

2.1.3.3 The material property assumptions are to use the characteristic values of yield strength and Young's Modulus. Where appropriate, a bi-linear isotropic elasto-plastic material model excluding strain rate effects is to be used or the Tangent Modulus is to be taken as a conservative value. A plastic tangent modulus of 1000MPa is acceptable for normal and higher strength steel.

2.1.4 Initial deflections – geometrical imperfections/out-of-flatness

2.1.4.1 Initial deflections are to be included in the buckling assessment.

2.1.4.2 For the deterministic strength assessment the geometrical imperfections are to be transformed to a regular model pattern.

2.1.4.3 The imperfections may be divided into local imperfections (plate out-of-flatness and stiffener sideways out-of-straightness), and global imperfections of the stiffeners (stiffener lateral/vertical out-of-straightness).

2.1.4.4 The shape of the initial deflections is to be such that the most critical failure modes are represented and triggered by the analysis. In general, a combination of the lowest buckling Eigen-modes will be appropriate.

Consideration is to be given in the case of plates with high slenderness and in the case of simultaneously acting loads, where the critical failure mode may be different from the lowest Eigen-modes.

2.1.4.5 The default maximum values of the imperfections are to be taken to be consistent with the *IACS Shipbuilding and Quality Repair Standard*. However, regular model imperfection amplitudes may generally be taken less than the maximum tolerance specified. The regular model imperfections may typically be case dependant (load ratio dependant) and are also to cover imperfections due to welding. The actual level of model imperfections will depend on the method of analysis, extension of model, etc. and deemed appropriate by the Society.

2.1.5 Welding induced residual stress

2.1.5.1 Residual stresses are not required to be explicitly included in the buckling assessment, see 2.1.4.5.

2.1.6 Interactions between buckling modes and structural elements

2.1.6.1 The advanced buckling analysis method is to accurately model the interactions between the various structural components and hence between the different buckling modes.

2.1.6.2 All the critical initial imperfection shapes are to be included, see **2.1.4**.

2.1.7 Simultaneous acting loads

2.1.7.1 The method is to be able to model any combination of biaxial in-plane compressive and shear membrane loads and lateral pressure.

2.1.7.2 Any lateral pressure is to be applied first, in order to generate the deformed shape. The lateral pressure is then to be kept constant.

2.1.7.3 The effect of lateral pressure enforcing deflections in different patterns than in-plane loads is to be included in such a way that the most critical buckling mode is developed.

2.1.8 Boundary conditions

2.1.8.1 The boundary conditions are to represent the actual response of the plate or stiffened panel. In-plane and out-of-plane boundary conditions are to be considered.

2.1.8.2 Where a panel is an integral part of a larger continuous area of stiffened plating, such as bottom or side panels, the edges may be taken as free to move in-plane, but forced to remain straight. Where a panel is not supported in-plane by adjacent structure, such as a stringer web panel or bottom girder web, then the edges are to be considered as completely free.

2.1.8.3 Rotational restraint on the plate from the stiffeners is to be accounted for by direct analysis of the plate and stiffener interaction. Prescribed boundary conditions are, in general, not acceptable.

2.1.8.4 The panels can be taken as supported in the lateral/vertical direction at the primary support members. The stiffeners may be taken as horizontally supported at the crossing of primary support members (preventing tilting at crossings). Geometrical rotational restraint of the plate from the primary support members is to be neglected.

2.1.9 Model extent

2.1.9.1 The extent of the model used in the buckling assessment is to be sufficient to account for the structure that is surrounding the panel of interest, and to reduce the uncertainties introduced through the boundary conditions.

2.1.9.2 In general, the model is to include more than one stiffener span in the stiffener direction and the portion between two primary support members in the direction normal to the stiffeners.

2.1.10 Element size for non-linear finite element models

2.1.10.1 The element size is to be small enough to describe the buckling deflections accurately.

2.1.10.2 The mesh size will depend on the complexity of the geometry and loads and the type of element used, but a minimum of five elements across a half-buckling wave length is generally required.

3. Application and Structural Modelling Principles

3.1 General

3.1.1 Scope

3.1.1.1 The following specifies the standard assumptions to be applied for the application of the advanced buckling method. These assumptions may be refined when the advanced buckling method is capable of more accurate representation of the structure.

3.1.2 Boundary conditions

3.1.2.1 The boundary conditions are to accurately account for the in-plane and rotational constraints imposed by the adjacent structures (such as stiffeners, primary support members and adjacent plates). The assumptions defined in 3.1.2.3 to 3.1.2.4 are to be applied.

3.1.2.2 The boundary conditions are divided into two main groups being representative for “free edge plating” and “continuous plating”. The latter group represents large stiffened panels such as deck plating, bottom plating, ship sides, etc., while the other represents girders, floors, stringers, etc.

3.1.2.3 The continuous plating condition is representative for elements having in-plane support conditions by the surrounding structure. The boundary conditions for stiffened panels are to be taken as:

- (a) panel edges perpendicular to stiffeners are to be considered simply supported
- (b) panel edges parallel to stiffeners are to be considered as having rotational support equivalent to that provided by stiffeners within the panel
- (c) the ends of stiffeners are to be considered as part of a continuous panel and supported sideways by the primary support members
- (d) all edges of the panel are to be constrained to remain straight but are free to displace inwards.

3.1.2.4 Free edge plating conditions are representative for elements having weak in-plane support along one or more edges, e.g. vertically stiffened double bottom floors. The boundary conditions for stiffened panels are to be taken as:

- (a) panel edges perpendicular to stiffeners are to be considered simply supported
- (b) panel edges parallel to stiffeners are to be considered as having rotational support equivalent to that provided by stiffeners within the panel
- (c) the ends of stiffeners are to be considered as supported sideways when attached directly to adjacent structure, otherwise they are to be assumed simply supported
- (d) all free edges of the panel are free to displace inwards. Rotational restraints of the edge reinforcements on the free edges may be considered.

3.1.2.5 The boundary conditions for un-stiffened panels are to be taken as:

- (a) panel edges are to be considered simply supported unless otherwise stated
- (b) free edges of the panel, if any, are free to displace inwards. The continuous edges are to be constrained to remain straight.

3.1.3 Structural idealisation

3.1.3.1 The structural modelling and buckling assessment method applicable for free edge plating is to be taken as:

- (a) parallel to the stiffener direction: one frame bay is normally sufficient for structures having significant stress gradients. For uniformly compressed elements with the free edges parallel to the stiffener direction, such as longitudinal girders, multi-bay models are to be considered
- (b) normal to the stiffener direction: between primary support members, but may be limited to six stiffener spacings
- (c) assessment method: Method 2 - buckling capacity with no allowance for redistribution of load unless otherwise specified.

3.1.3.2 The structural modelling and buckling assessment method applicable for continuous plating is to be taken as:

- (a) parallel to the stiffener direction: at least two frame bays, in order to model imperfections between adjacent panels

- (b) normal to the stiffener direction: between primary support members, but may be limited to six stiffener spacings
- (c) assessment method: Method 1 - buckling capacity with allowance for redistribution of load unless otherwise specified.

4. Assessment Criteria

4.1 General

4.1.1 Buckling strength assessment methods

4.1.1.1 The buckling capacity value is to be based on one of the following assessment methods:

1. Buckling Capacity with allowance for redistribution of load
2. Buckling Capacity with no allowance for redistribution of load

The application of which assessment method to use is given in **3.1.3**

4.1.2 Method 1: Buckling capacity with allowance for redistribution of load

4.1.2.1 The buckling capacity value is to be taken as the load that results in the first occurrence of membrane yield stress anywhere in the stiffened panel. This includes the redistribution of load as indicated in **1.1.3.2**. In particular the following locations are to be checked for von Mises stresses equivalent to yield:

- (a) at the edges of the plate
- (b) along the line of intersection of the plate and stiffeners, especially at the ends of the stiffener and at the stiffener mid point
- (c) along the flanges of the stiffeners, especially at the ends of the stiffener and at the stiffener mid point.

4.1.3 Method 2: Buckling capacity with no allowance for redistribution of load

4.1.3.1 The buckling capacity value or the load that results in the first occurrence of membrane yield stress anywhere in the stiffened panel, see **1.1.3.3**.

4.2 Utilisation Factors

4.2.1 General

4.2.1.1 The utilisation factor, η , is used as a measure of safety margin against buckling strength failure. The utilisation factor is defined as the ratio between the applied loads and the corresponding ultimate capacity or buckling strength.

4.2.1.2 A structure is considered to have an acceptable buckling strength if it satisfies the following criteria:

$$\eta_{act} \leq \eta_{allow}$$

Where:

η_{allow} : allowable buckling utilisation factor, as defined in **Section 9/2.2.5**

η_{act} : actual buckling utilisation factor based on the applied design loads

4.2.1.3 For combined loads, the utilisation factor, η , is to be taken as the ratio between the applied equivalent load and the corresponding buckling capacity, see **Fig. D.4.1**, and is to be taken as:

$$\eta = \frac{W_{act}}{W_u}$$

Where:

W_{act} : applied equivalent load due to the combined membrane loads
 $= \sqrt{\sigma_{dx}^2 + \sigma_{dy}^2 + \tau_d^2} \quad (N/mm^2)$

W_u : equivalent load due to the combined membrane loads which results in the buckling capacity point, see **Fig. D.4.1**
 $= \sqrt{\sigma_{cx}^2 + \sigma_{cy}^2 + \tau_{cr}^2} \quad (N/mm^2)$

Where the combined loads are all factored by the same ratio and the applied pressure load is to be kept constant

σ_{dx} : applied axial stress in x direction, in N/mm^2

σ_{dy} : applied axial stress in y direction, in N/mm^2

τ_d : applied shear stress, in N/mm^2

σ_{cx} : buckling strength due to compression in x direction, in N/mm^2

σ_{cy} : buckling strength due to compression in y direction, in N/mm^2
 τ_{cr} : buckling strength in shear, in N/mm^2

Fig. D.4.1 Definition of Utilisation Factor Example Showing a Bi-Axial Loading Pattern

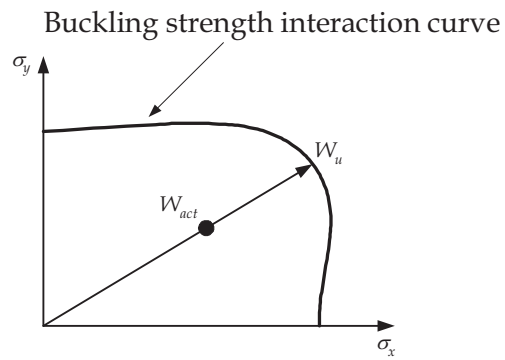

5. Strength Assessment (FEM) – Buckling Procedure

5.1 General

5.1.1 Scope

5.1.1.1 The following procedure is to be used for the assessment of the buckling requirements for the Strength Assessment (FEM) as part of the Design Verification procedure, see **Section 9/2**.

5.1.1.2 All structural elements in the finite element analysis are to be assessed individually. Each stiffener with attached plate and all un-stiffened panels are to be assessed.

5.1.1.3 The buckling performance of each member is considered acceptable if it satisfies the following criterion:

$$\eta_{act} \leq \eta_{allow}$$

Where

η_{allow} : allowable buckling utilisation factor, as defined in **Section 9/2.2.5**

η_{act} : actual buckling utilisation factor based on the applied design loads, see **4.2.1**

5.2 Structural Modelling and Capacity Assessment Method

5.2.1 General

5.2.1.1 The longitudinally effective structure of the hull girder is to be modelled as stiffened panels or un-stiffened panels as specified in **Table D.5.1** and **Fig. D.5.1**. These provide the standard assumptions to be used for the buckling capacity assessment method.

5.2.1.2 The structural models are to be based on the net thickness obtained by deducting the full corrosion addition, i.e. $-1.0t_{corr}$, and any owner's extras from the proposed thickness. This thickness reduction applies to the plating and the stiffener web and face plate.

5.2.2 Stiffened panels

5.2.2.1 Each stiffener with attached plate is to be represented as a stiffened panel of the extent defined in **Table D.5.1** and hence is assumed to be part of a larger structural entity to correctly model the overall buckling behaviour.

5.2.2.2 In general, the assessment method is to model changes in plate thickness, stiffener size and spacing. However where the advanced buckling method is unable to correctly model these changes, the calculations are to be performed separately for each stiffener and plate between the stiffeners. Plate thickness, stiffener properties and stiffener spacing at the considered location are to be assumed for the whole panel. If the plate thickness, stiffener properties and stiffener spacing varies within the stiffened panel, the calculations are to be performed for all configurations of the panel. Where the panel between stiffeners consists of several plate thickness the weighted average thickness may be used for the thickness of the plating for assessment of the corresponding stiffener/plating combination. Calculation of weighted average is to be in accordance with **5.2.3.3**. See **Fig. D.5.6**.

5.2.3 Un-stiffened panels

5.2.3.1 The assessment method is to model changes in plate thickness and panel geometry.

5.2.3.2 In way of web frames, stringers and brackets, the geometry of the panel (i.e. plate bounded by web stiffeners/face plate) may not have a rectangular shape. Where the advanced buckling method is unable to correctly model the panel geometry, then an equivalent rectangular panel is to be defined as shown in **Fig. D.5.5**. Where web stiffeners are not connected to the intersecting stiffeners, then the panel may be defined as shown in **Fig. D.5.6**. The FE analysis is to represent the actual structure in order to derive realistic stress values for application to the equivalent rectangular panel. The stresses of all elements whose centroids are within the equivalent plate panel are to be connected for stress average in accordance with **5.3.2.1**.

5.2.3.3 Where the advanced buckling method is unable to correctly model changes in net plate thickness across a panel, and the panel consists of a number of finite plate elements, then the average thickness is to be taken as:

$$t_{avr} = \frac{\sum A_j t_j}{\sum A_j}$$

Where:

A_j : area of the j th plate element making up the panel

t_j : net thickness of the j th plate element making up the panel

Table D.5.1 Structural Elements for the Strength Assessment (FEM)

Structural Elements	Idealisation	Assessment method ⁽¹⁾	Normal panel definition ⁽²⁾
Longitudinal structure, see Fig. D.5.1			
Longitudinally stiffened panels Shell envelope Deck Inner hull Hopper tank side Longitudinal bulkheads Centreline bulkheads	Stiffened panel	Method 1	Length: between web frames Width: between primary support members (PSM) ⁽²⁾
Double bottom longitudinal girders in line with longitudinal bulkhead or connected to hopper tank side	Stiffened panel	Method 1	Length: between web frames Width: full web depth
Web of horizontal girders in double side tank connected to hopper tank side	Stiffened panel	Method 1	Length: between web frames Width: full web depth
Web of double bottom longitudinal girders not in line with longitudinal bulkhead or not connected to hopper tank side	Stiffened panel	Method 2	Length: between web frames Width: full web depth
Web of horizontal girders in double side tank not connected to hopper tank side	Stiffened panel	Method 2	Length: between web frames Width: full web depth
Web of single skin longitudinal girders	Un-stiffened panel	Method 2	Between local stiffeners/face plate/PSM
Transverse structure, see Fig. D.5.2			
Web of transverse deck girders including brackets	Un-stiffened panel	Method 2	Between local stiffeners/face plate/PSM
Vertical web in double side tank	Stiffened panel	Method 2	Length: full web depth Width: between primary support members
All irregularly stiffened panels, e.g. Web panels in way of hopper tank and bilge	Un-stiffened panel	Method 2	Between local stiffeners/face plate/PSM
Double bottom floors	Stiffened panel	Method 2	Length: full web depth Width: between primary support members
Vertical web frame including brackets	Un-stiffened panel	Method 2	Between vertical web stiffeners/face plate/PSM
Cross tie web plate	Un-stiffened panel	Method 2	Between vertical web stiffeners/face plate/PSM
Transverse Oil-tight and Watertight bulkheads, see Fig. D.5.3 and Transverse wash bulkheads, see Fig. D.5.4			
All regularly stiffened bulkhead panels	Stiffened panel	Method 1	Length: between primary support members Width: between primary support members
Regularly stiffened bulkhead with secondary buckling stiffeners perpendicular to regular stiffeners ⁽³⁾	Stiffened panel	Method 1	Length: between primary support members Width: between primary support members
All irregularly stiffened bulkhead panels, e.g. web panels in way of hopper tank and bilge	Un-stiffened panel	Method 2	Between local stiffeners/face plate
Web plate of bulkhead stringers including brackets	Un-stiffened panel	Method 2	Between web stiffeners /face plate

Table D.5.1(Continued) Structural Elements for the Strength Assessment (FEM)

Structural Elements	Idealisation	Assessment method ⁽¹⁾	Normal panel definition ⁽²⁾
Transverse Corrugated bulkheads			
Upper/lower stool including stiffeners	Stiffened panel	Method 1	Length: between internal web diaphragms Width: length of stool side
Stool internal web diaphragm	Un-stiffened panel	Method 2	Between local stiffeners /face plate / PSM

Notes:

1. The assessment method specifies which buckling strength assessment method is to be used, see **4.1**
2. See structural idealisation, **3.1.3**.
3. The secondary stiffener can be modelled as “sniped” or “continuous”. The stiffener is considered “sniped” unless rotational end supports are provided at both ends.
An area stiffened by irregular buckling stiffeners only should be assessed by considering each plate in the panel as Unstiffened panel using Method 2.

Fig. D.5.1 Advanced Buckling Assessment for longitudinal strength

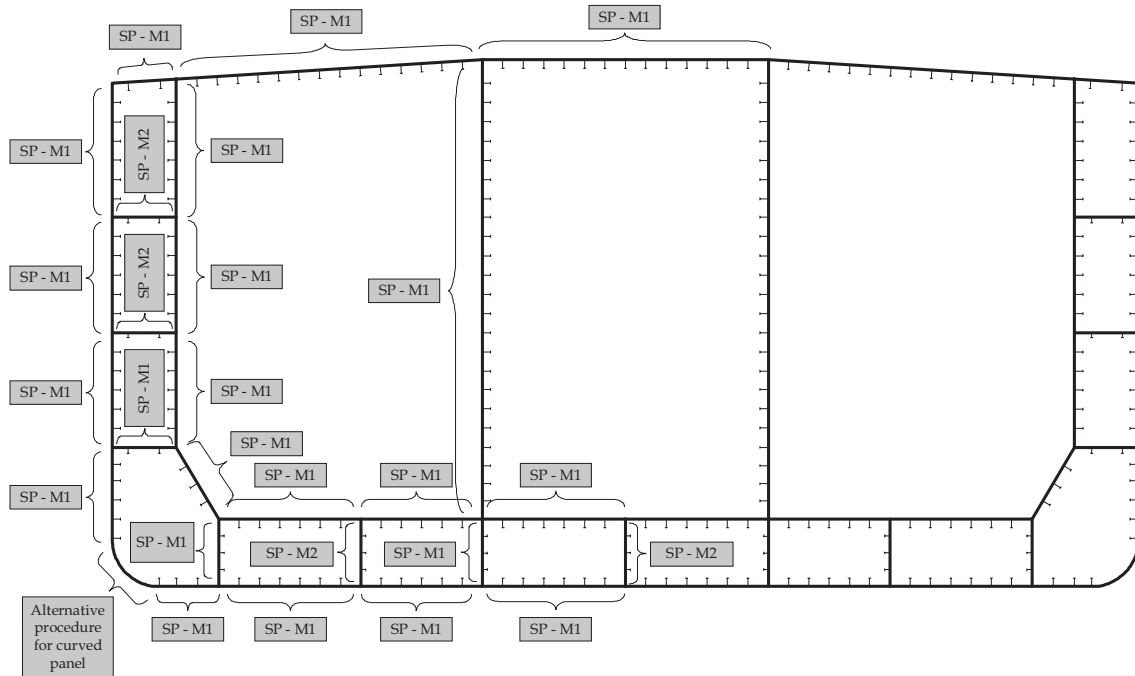

Notes:

SP – M1 denotes stiffened panel – buckling strength assessed using Method 1

SP – M2 denotes stiffened panel – buckling strength assessed using Method 2

Fig. D.5.2 Transverse Web Frames

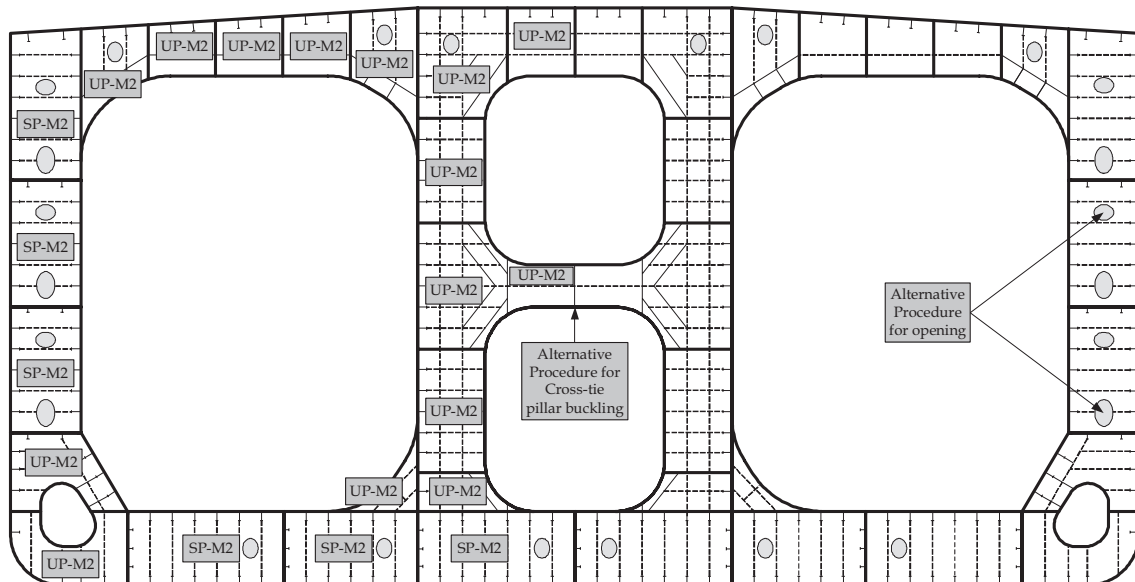

Notes:

SP – M1 denotes Stiffened Panel – buckling strength assessed using Method 1

UP – M2 denotes Un-stiffened Panel – buckling strength assessed using Method 2

SP – M2 denotes Stiffened Panel – buckling strength assessed using Method 2

Fig. D.5.3 Transverse Bulkhead

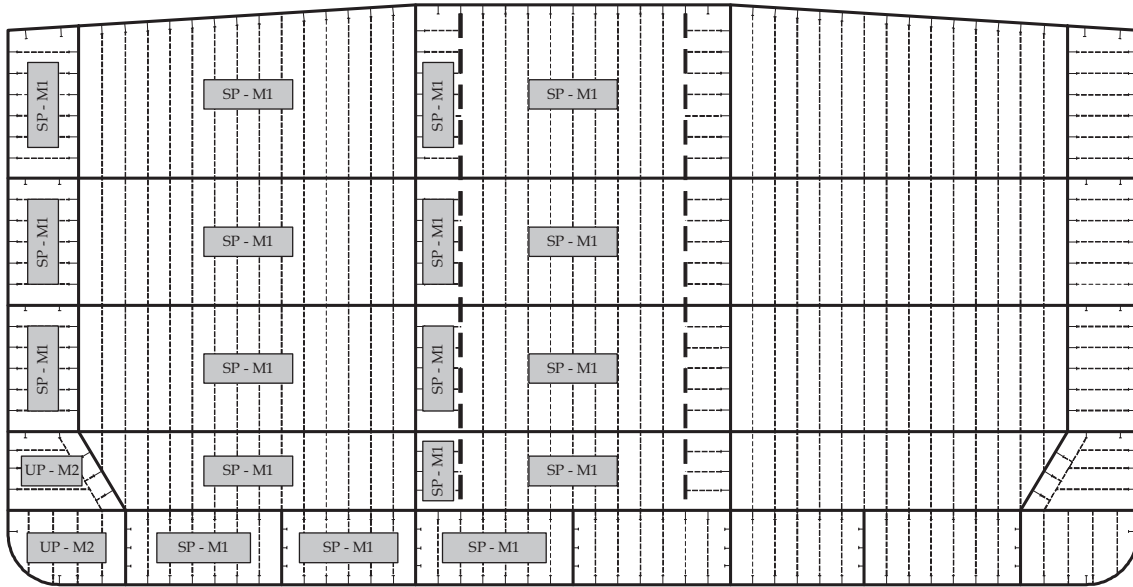

Notes:

SP – M1 denotes Stiffened Panel – buckling strength assessed using Method 1.

UP – M2 denotes Un-stiffened Panel – buckling strength assessed using Method 2

Fig. D.5.4 Cross Tie

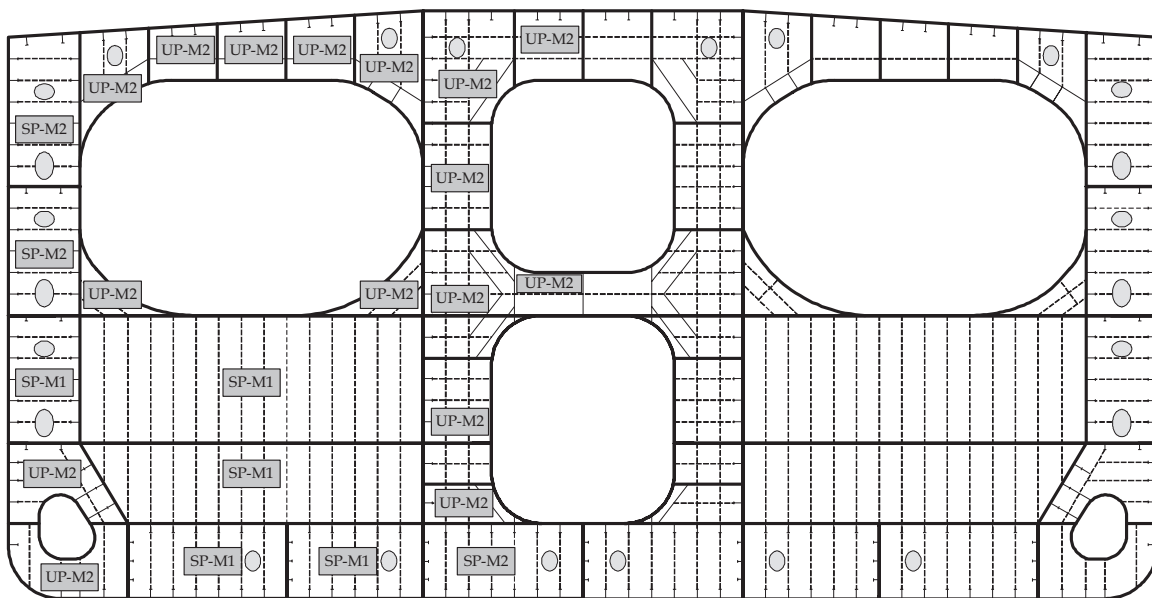

Notes:

SP – M1 denotes Stiffened Panel – buckling strength assessed using Method 1

UP – M2 denotes Un-stiffened Panel – buckling strength assessed using Method 2

SP – M2 denotes Stiffened Panel – buckling strength assessed using Method 2

Fig. D.5.5 Modelling of an Un-stiffened Panel with Irregular Geometry

(a) The four corners closest to a right angle, 90degrees , in the bounding polygon for the plate are identified

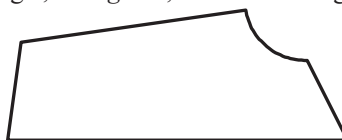

(b) The distances along the plate bounding polygon between the corners are calculated, i.e. the sum of all the straight line segments between the end points

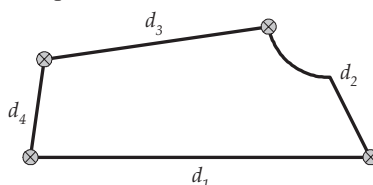

(c) The pair of opposite edges with the smallest total length is identified, i.e. minimum of d_1+d_3 and d_2+d_4

(d) A line is joined between the middle points of the chosen opposite edges (i.e. a mid point is defined as the point at half the distance from one end). This line defines the longitudinal direction, x_1 , for the capacity model. The length of the line defines the length of the capacity model, l_1 or l_2 measured from one end point.

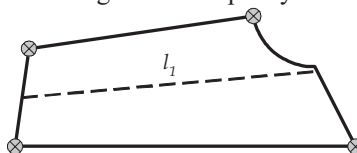

(e) The width of the model, l_2 , is to be taken as:

$$l_2 = A_{pl} / l_1$$

Where:

A_{pl} : area of the plate

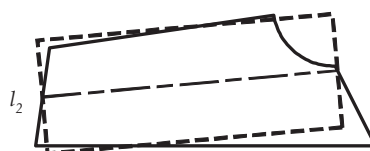

(f) The stresses from the FE analysis are to be resolved into the local coordinate system of the equivalent rectangular panel. These stresses are to be used for the buckling assessment.

Fig. D.5.6 Capacity Model for Web Plate

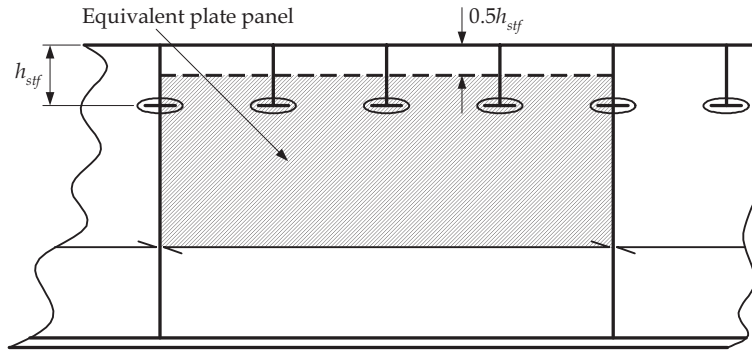

Note

The correction of panel breadth is applicable also for other slot configurations provided that the web or collar plate is attached to at least one side of the passing stiffener.

5.3 Load Application

5.3.1 General

5.3.1 The ultimate capacity or buckling strength is to be assessed for the effects of the combined bi-axial and shear membrane stresses acting on the structural panel.

5.3.1.2 The axial compressive and shear stress distribution is to be taken from the FE analysis and applied to the buckling model. The stresses from the FE analysis are not to be adjusted for the required change in thickness for buckling, i.e. $-0.5t_{corr}$ used in the FE analysis and $1.0t_{corr}$ used for the buckling assessment.

5.3.1.3 The lateral pressure applied to the FE analysis is also to be applied to the buckling assessment.

5.3.1.4 The stresses may be applied by means of enforced displacements obtained from the finite element analysis to the panel edges or by loads applied to the panel edges.

5.3.1.5 Where the advanced buckling method is unable to correctly model changes in axial or shear stress across a panel, then the stresses and pressures may be averaged as defined in 5.3.2 and 5.3.3.

5.3.2 Average membrane stresses

5.3.2.1 When the plate panel consists of a number of finite plate elements, the average membrane stress is to be calculated using a weighted average approach, as given by:

$$\sigma_{xm} = \frac{\sum_1^n A_i \sigma_{xmi}}{\sum_1^n A_i} \quad (N/mm^2)$$

$$\sigma_{ym} = \frac{\sum_1^n A_i \sigma_{ymi}}{\sum_1^n A_i} \quad (N/mm^2)$$

$$\tau_{xym} = \frac{\sum_1^n A_i \tau_{xyi}}{\sum_1^n A_i} \quad (N/mm^2)$$

Where:

σ_{xmi} : membrane stress in x -direction at the centroid of the i th plate element of the panel, in N/mm^2

σ_{ymi} : membrane stress in y -direction at the centroid of the i th plate element of the panel, in N/mm^2

τ_{xyi} : membrane shear stress at the centroid of the i th plate element of the panel, in N/mm^2

A_i : area of the i th plate element making up the panel, in mm^2

n : number of elements in the panel

When σ_{xmi} or σ_{ymi} are in tension, then the respective value is to be taken as zero.

5.3.3. Average lateral pressure

5.3.3.1 Where the plate panel consists of a number of finite elements, the average pressure, P_{avr} , is to be calculated using a weighted average approach, as given by:

$$P_{avr} = \frac{\sum_1^n A_i P_i}{\sum_1^n A_i} \quad (kN/m^2)$$

Where:

- P_i : pressure acting on the i th plate element making up the panel, in kN/m^2
 A_i : area of the i th plate element making up the panel, in mm^2
 n : number of elements in the panel

5.4. Limitations of the Advanced Buckling Assessment Method**5.4.1 General**

5.4.1.1 In the absence of a suitable advanced buckling method, then the following structural elements can be assessed according to **Table D.5.2**.

Table D.5.2 Requirements for structures where there is no advanced buckling method available

Structural elements	Buckling mode	Rule Reference
bilge plate	transverse elastic buckling	Section 8/2.2.3
primary support members	global (overall) buckling and torsional buckling	Section 10/2.3
web plate of primary support members in way of openings	buckling of web plate	Section 10/3.4
cross ties	global (overall) buckling	Section 10/3.5
corrugated bulkheads	flange panel buckling	Section 10/3.2
	global (overall) buckling	Section 10/3.5

6. Ultimate Hull Girder Strength Assessment

6.1 General

6.1.1 Scope

6.1.1.1 This procedure is required for the assessment of the ultimate hull girder strength assessment as part of the Design Verification procedure, see **Section 9/1**.

6.1.1.2 All structural elements of the strength deck are to be assessed individually.

6.2 Load Application

6.2.1 General

6.2.1.1 The uni-axial compressive stress used for the ultimate capacity assessment of longitudinally stiffened deck panels is to be calculated at the stiffener/plate intersection point.

6.2.1.2 The hull girder stresses are based on the section modulus properties using a deduction of half the corrosion addition, i.e. $-0.5t_{corr}$, and owner's extra from the proposed thickness.

6.2.1.3 Lateral pressure is not to be included in the buckling assessment for hull girder ultimate strength.

6.3 Structural Modelling and Buckling Assessment

6.3.1 General

6.3.1.1 The longitudinally effective structure of the strength deck is to be modelled as stiffened panels using Method 1 to derive the ultimate capacity.

6.3.1.2 Each deck stiffener with attached plate is to be represented as a stiffened panel with the transverse extent being between two adjacent primary support members.

6.3.1.3 The buckling capacity models are to be based on the net thickness obtained by deducting half the corrosion addition, i.e. $-0.5t_{corr}$, and any owner's extras from the proposed thickness. This thickness reduction applies to the plating and the stiffener web and face plate.

6.3.1.4 In general, the assessment method is to correctly model changes in plate thickness, stiffener size and spacing. However where the advanced buckling method is unable to correctly model these changes, the calculations are to be performed separately for each stiffener and plate between the stiffeners. Plate thickness, stiffener properties and stiffener spacing at the considered location are to be assumed for the whole panel. If the plate thickness, stiffener properties and stiffener spacing varies within the stiffened panel, the calculations are to be performed for all configurations of the panel.

MAJOR CHANGES AND EFFECTIVE DATES

Amendments to Part CSR-T of the RULES FOR THE SURVEY AND CONSTRUCTION OF STEEL SHIPS made between 2 January 2013 and 28 February 2015 and their effective dates are as follows:

I AMENDMENTS ON 27TH FEBRUARY 2015 (Rule No.16)

Section 1 Paragraph 1.1.1.1 has been amended.

EFFECTIVE DATE AND APPLICATION

1. The effective date of the amendments is 1 July 2015.
2. Notwithstanding the amendments to the Rules, the current requirements may apply to ships for which the date of contract for construction* is before the effective date.

*“contract for construction” is defined in the latest version of IACS Procedural Requirement (PR) No.29.

IACS PR No.29 (Rev.0, July 2009)

1. The date of “contract for construction” of a vessel is the date on which the contract to build the vessel is signed between the prospective owner and the shipbuilder. This date and the construction numbers (i.e. hull numbers) of all the vessels included in the contract are to be declared to the classification society by the party applying for the assignment of class to a newbuilding.
2. The date of “contract for construction” of a series of vessels, including specified optional vessels for which the option is ultimately exercised, is the date on which the contract to build the series is signed between the prospective owner and the shipbuilder. For the purpose of this Procedural Requirement, vessels built under a single contract for construction are considered a “series of vessels” if they are built to the same approved plans for classification purposes. However, vessels within a series may have design alterations from the original design provided:
 - (1) such alterations do not affect matters related to classification, or
 - (2) If the alterations are subject to classification requirements, these alterations are to comply with the classification requirements in effect on the date on which the alterations are contracted between the prospective owner and the shipbuilder or, in the absence of the alteration contract, comply with the classification requirements in effect on the date on which the alterations are submitted to the Society for approval.The optional vessels will be considered part of the same series of vessels if the option is exercised not later than 1 year after the contract to build the series was signed.
3. If a contract for construction is later amended to include additional vessels or additional options, the date of “contract for construction” for such vessels is the date on which the amendment to the contract, is signed between the prospective owner and the shipbuilder. The amendment to the contract is to be considered as a “new contract” to which **1.** and **2.** above apply.
4. If a contract for construction is amended to change the ship type, the date of “contract for construction” of this modified vessel, or vessels, is the date on which revised contract or new contract is signed between the Owner, or Owners, and the shipbuilder.

Note:

This Procedural Requirement applies from 1 July 2009.

RULES FOR THE SURVEY AND CONSTRUCTION OF STEEL SHIPS

Part CSR-T Common Structural Rules for Double Hull Oil Tankers

Rules for the Survey and Construction of Steel Ships
Part CSR-T 2015 AMENDMENT NO.1

Rule No.16 27th February 2015

Resolved by Technical Committee on 2nd February 2015

Approved by Board of Directors on 23rd February 2015

ClassNK
NIPPON KAIJI KYOKAI

Rule No.16 27th February 2015
AMENDMENT TO THE RULES FOR THE SURVEY AND CONSTRUCTION OF STEEL SHIPS

“Rules for the survey and construction of steel ships” has been partly amended as follows:

Part CSR-T COMMON STRUCTURAL RULES FOR DOUBLE HULL OIL TANKERS

Section 1 INTRODUCTION

1. Introduction to Common Structural Rules for Oil Tankers

1.1 General

1.1.1 Applicability

Sub-paragraph 1.1.1.1 has been amended as follows.

1.1.1.1 This Part apply to double hull oil tankers of 150m length, L_{CSR-T} , and upward classed with the Society and contracted for construction⁽¹⁾ on or after 1 April 2006 but before 1 July 2015. The definition of the rule length, L_{CSR-T} , is given in **Section 4/1.1.1.1**.

EFFECTIVE DATE AND APPLICATION

1. The effective date of the amendments is 1 July 2015.
2. Notwithstanding the amendments to the Rules, the current requirements may apply to ships for which the date of contract for construction* is before the effective date.
* “contract for construction” is defined in the latest version of IACS Procedural Requirement (PR) No.29.

IACS PR No.29 (Rev.0, July 2009)

1. The date of “contract for construction” of a vessel is the date on which the contract to build the vessel is signed between the prospective owner and the shipbuilder. This date and the construction numbers (i.e. hull numbers) of all the vessels included in the contract are to be declared to the classification society by the party applying for the assignment of class to a newbuilding.
2. The date of “contract for construction” of a series of vessels, including specified optional vessels for which the option is ultimately exercised, is the date on which the contract to build the series is signed between the prospective owner and the shipbuilder.
For the purpose of this Procedural Requirement, vessels built under a single contract for construction are considered a “series of vessels” if they are built to the same approved plans for classification purposes. However, vessels within a series may have design alterations from the original design provided:
 - (1) such alterations do not affect matters related to classification, or
 - (2) If the alterations are subject to classification requirements, these alterations are to comply with the classification requirements in effect on the date on which the alterations are contracted between the prospective owner and the shipbuilder or, in the absence of the alteration contract, comply with the classification requirements in effect on the date on which the alterations are submitted to the Society for approval.The optional vessels will be considered part of the same series of vessels if the option is exercised not later than 1 year after the contract to build the series was signed.
3. If a contract for construction is later amended to include additional vessels or additional options, the date of “contract for construction” for such vessels is the date on which the amendment to the contract, is signed between the prospective owner and the shipbuilder. The amendment to the contract is to be considered as a “new contract” to which **1.** and **2.** above apply.
4. If a contract for construction is amended to change the ship type, the date of “contract for construction” of this modified vessel, or vessels, is the date on which revised contract or new contract is signed between the Owner, or Owners, and the shipbuilder.

Note:

This Procedural Requirement applies from 1 July 2009.