

Subject

Introduction to the Outcomes of MSC 97

# **ClassNK**

## **Technical Information**

No. TEC-1105

Date 21 March 2017

To whom it may concern

The ninety-seventh session of the Maritime Safety Committee (MSC 97) was held at the IMO in London, U.K. from 21 to 25 November 2016. Since the minutes, resolutions and circulars of the meeting were recently released from the IMO, a summary of the decisions taken at MSC 97 is provided as below for your information.

1. Adopted mandatory requirements

Mandatory requirements adopted at MSC 97 are as follows:

(1) Foam-type extinguisher required for boiler space (See attachment 1)

Amendments to SOLAS II-2/10.5, not to require foam-type extinguisher of at least 135L capacity in the boiler space which is protected by fixed water-based local application fire-extinguishing systems were adopted.

Applied: on or after 1 January 2020

(2) Harmonization of survey period of cargo ships not subject to ESP Code (See attachment 1)

New SOLAS XI-1/2-1, requirements to harmonize the survey periods of cargo ships not subject to the ESP Code (hereinafter non-ESP ships) and ESP ships, were adopted. This adoption accepts split survey for non-ESP ships, as well as ESP ships.

Applied: on or after 1 January 2020

(3) Amendments to SOLAS II-1 on application of Code on Noise levels on board ships (See attachment 1)

Amendments to SOLAS II-1/3-12, to clarify that the former Code (A.468(XII)) applies to ships delivered before 1 July 2018, contracted for construction before 1 July 2014 and the keels of which are laid on or after 1 January 2009, were adopted.

Applied: on or after 1 January 2020

(To be continued)

NOTES:

- ClassNK Technical Information is provided only for the purpose of supplying current information to its readers.
- ClassNK, its officers, employees and agents or sub-contractors do not warrant the accuracy of the information contained herein and are not liable for any loss, damage or expense sustained whatsoever by any person caused by use of or reliance on this information.
- Back numbers are available on ClassNK Internet Homepage (URL: [www.classnk.or.jp](http://www.classnk.or.jp)).

- (4) Requirements for fire integrity of wheelhouse window for ships carrying liquefied gases in bulk (See attachments 2, 16)

Amendments to paragraph 3.2.5 of IGC Code Chapter 3 were adopted, for deletion of the provision that the wheelhouse windows shall be constructed not less than "A-0" class. In addition, the relevant circular (MSC.1/Circ.1549) regarding its application was approved.

Applied: on or after 1 January 2020

- (5) Amendments to ESP Code (See attachment 3)

Amendments to ESP Code, to clarify the scope of close up survey and thickness measurement for double hull bulk carriers, were adopted.

Applied to: on or after 1 July 2018

- (6) Amendments to 2008 IS Code (See attachments 4, 5 and 6)

Amendments to 2008 IS Code were adopted in order to include recommendations regarding the intact stability criteria and stability information for ships engaged in anchor handling operations, towing operations, escort operations and lifting operations.

Applied: on and after 1 January 2020

- (7) Amendments to STCW Convention (See attachments 7 and 8)

Amendments to STCW Convention and STCW Code were adopted in order to revise training requirements for masters and deck officers on board ships operating in polar waters. For seafarers who commence approved seagoing service in polar waters prior to 1 July 2018, transitional provisions were stipulated and will be applied until 1 July 2020. Besides, training requirements for masters, officers, ratings and other personnel serving on board passenger ships engaged on international voyages were adopted.

Applied: on and after 1 July 2018

## 2. Approved mandatory requirements

Following mandatory requirements were approved at this session, which are expected to be considered for adoption at MSC 98 in June 2017.

- (1) Requirements for fire integrity of wheelhouse window for ships using gases or other low-flashpoint fuels (See attachment 9)

Amendments to 11.3.2 of the IGF Code Chapter 11 were approved, for deletion of the provision that the wheelhouse windows facing the fuel tanks on open deck shall be constructed not less than "A-0" class, in line with the adoption of amendments to paragraph 3.2.5 of the IGC Code Chapter 3.

(To be continued)

- (2) Fire integrity of window for ships carrying not more than 36 passengers (See attachment 10)  
Amendments to SOLAS II-2/9.4.1.3, which requires fire integrity at least equal to "A-0" class for windows facing survival craft, embarkation and assembly stations, external stairs and open decks used for escape routes, and windows situated below liferaft and escape slide embarkation areas on ships carrying not more than 36 passengers, were approved.
  - (3) Amendments to IMSBC Code (See attachment 11)  
Amendments to paragraph 4.5.1 and 4.5.2 of IMSBC Code, to clarify that the shipper shall be responsible for conducting a test to determine the TML of a solid bulk cargo and sampling and testing for moisture content before loading, were approved.
  - (4) Requirements applied to vehicle space (See attachment 12)  
Amendments to SOLAS II-2/20 were approved, so that cargo spaces are not required to comply with SOLAS II-2/20, subject to the contained vehicles do not use their own propulsion within the cargo space at loading/unloading, and the vehicles are carried in compliance with the appropriate requirements of regulation 19 and IMDG Code.
3. The following unified interpretations (UIs) and others were approved during MSC 97. IACS UIs shown as below are available on IACS website (<http://www.iacs.org.uk/>).

### 3.1 Unified Interpretations (UIs)

- (1) Unified interpretation of lamps installed in the area where remotely located survival craft are stowed (SOLAS III/31.1.4) (See attachment 14)  
MSC 97 approved an interpretation that self-contained battery-powered lamps may be accepted as means of illumination supplied from the emergency source of electrical power for the area where remotely located survival craft are stowed as required by SOLAS III/31.1.4. (UI SC213)
- (2) Unified interpretation of pilot transfer arrangements (SOLAS V/23.3.3) (See attachment 15)  
MSC 97 approved an interpretation for SOLAS V/23.3.3 on installation of an accommodation ladder used in conjunction with the pilot ladder in case where the height from the water to the point of access to the ship is more than 9 m that an adverse list of 15° is not necessary to be considered for calculation of the height from the water to the point of access to or egress from the ship. (UI SC257)
- (3) Unified interpretation related to inert gas supply to double hull spaces (SOLAS II-2/4.5.5.1) (See attachment 17)  
MSC 97 approved an interpretation that cargo pump-rooms and ballast pump-rooms are not regarded as one of double-hull spaces required to be fitted with suitable connections for the supply of inert gas as per SOLAS regulation II-2/4.5.5.1. (UI SC272)

(To be continued)

- (4) Unified interpretation of bulkhead between the wheelhouse and toilet inside the wheelhouse (SOLAS II-2/9) (See attachment 17)  
MSC 97 approved an interpretation that a bulkhead separating the wheelhouse and the toilet, installed completely within the wheelhouse, requires no fire integrity.
- (5) Unified interpretation of suitable number of spare air cylinders to be provided in connection with drills (SOLAS II-2/15.2.2.6) (See attachment 17)  
MSC 97 approved an interpretation that a suitable number of spare air cylinders to be carried on board to replace those used for fire drills as required by SOLAS II-2/15.2.2.6 should be at least one set of cylinders for each mandatory breathing apparatus, in addition to the spare cylinders required by SOLAS II-2/10.10.2.5. (UI SC275)
- (6) Unified interpretation of portable atmosphere testing instruments for enclosed spaces (SOLAS XI-1/7) (See attachment 18)  
MSC 97 approved an interpretation that the calibration of portable atmosphere testing instruments ashore in accordance with the manufacturer's instructions may be accepted as a means of complying with SOLAS XI-1/7.

### 3.2 Guidance

- (1) Amendments to guidance on the validity of radiocommunications equipment installed and used on ships (MSC.1/Circ.1460/Rev.1) (See attachment 13)  
MSC 97 approved to amend the current guidance (MSC.1/Circ.1460) to ensure HF radiocommunication equipment capable of operating NBDP (narrow-band direct printing) should be updated by the date of first radio survey after 1 January 2024, extending the date from 1 January 2017.

## 4. Others

- (1) The amendments to the GBS (Goal Based Standards) Verification Guidelines  
GBS, as stipulated in SOLAS II-1/3-10, is applied to oil tankers and bulk carriers of length 150m or above, contracted for construction on or after 1 July 2016. Design and construction of these ships shall comply with rules deemed as compliant with GBS. Further, GBS requires periodical verification of the rules as conforming to the goals and functional requirements of GBS based on the GBS verification guidelines (MSC.296(87)).

At the last session, it was noted that there was room for improvement of the guidelines and agreed to consider amendments to the guidelines from this session. The GBS verification guidelines are constituted by the following two parts:

Part A Verification process

Part B Information/documentation requirements and evaluation criteria

(To be continued)

At this session, as a result of deliberation on the amendments to Part A of the guidelines, it was agreed to amend the definitions of the terms in the guidelines. Further, it was also agreed to continue to consider the scope and frequency of maintenance verification at MSC 98. Upon completion of review of Part A and Part B, the amendments to the guidelines are expected to be adopted at MSC100 in November 2018.

(2) New requirements for ventilation of survival crafts

MSC 97 approved a plan to develop new requirements for ventilation of survival crafts, taking into account the discomfort experienced by many crew members while using a lifeboat. This new agenda item will be considered at SSE 4 in March 2017 with a view to amend the LSA Code.

(3) Amendments to guidelines for simulated launching of free-fall lifeboats

Guidelines for simulated launching of free-fall lifeboats have been stipulated in Annex 2 of MSC/Circ.1206/Rev.1. Despite efforts to reduce lifeboat accidents, serious accidents still occur due to the unintentional release of the free-fall lifeboat when conducting simulated launching as required by the guidelines.

At this session, as a result of deliberation on the proposal to amend the guidelines, it was agreed to consider this further at SSE 4.

(4) Amendments to requirements on subdivision and damage stability

At the last session, the amendments to SOLAS II-1 on subdivision and damage stability, which have been considered since 2010, were approved.

- (i) Required subdivision index R for passenger ships (Regulation 6)
- (ii) Wells constructed in the double bottom (Regulation 9)
- (iii) Use of butterfly valve to the collision bulkhead inside the forepeak of cargo ships (Regulation 12)
- (iv) Damage control drills for passenger ships (Regulation 19-1)

At this session, as a result of the deliberation of the above amendments and as supported by the majority, it was agreed to further consider the required subdivision index R for passenger ships. The above four amendments are expected to be adopted at MSC 98.

(To be continued)

For any questions about the above, please contact:

NIPPON KAIJI KYOKAI (ClassNK)

External Affairs Department, Administration Center Annex, Head Office

Address: 3-3 Kioi-cho, Chiyoda-ku, Tokyo 102-0094, Japan

Tel.: +81-3-5226-2038

Fax: +81-3-5226-2734

E-mail: xad@classnk.or.jp

Attachment:

1. RESOLUTION MSC.409(97)
2. RESOLUTION MSC.411(97)
3. RESOLUTION MSC.412(97)
4. RESOLUTION MSC.413(97)
5. RESOLUTION MSC.414(97)
6. RESOLUTION MSC.415(97)
7. RESOLUTION MSC.416(97)
8. RESOLUTION MSC.417(97)
9. DRAFT AMENDMENTS TO THE INTERNATIONAL CODE OF SAFETY FOR SHIPS USING GASES OR OTHER LOW-FLASHPOINT FUELS (IGF CODE)
10. DRAFT AMENDMENTS TO SOLAS REGULATION II-2/9.4.1.3
11. DRAFT AMENDMENTS TO PARAGRAPHS 4.5.1 AND 4.5.2 OF THE IMSBC CODE
12. DRAFT AMENDMENTS TO SOLAS REGULATION II-2/20.2
13. MSC.1/Circ.1460/Rev.1
14. MSC.1/Circ.1490/Rev.1
15. MSC.1/Circ.1495/Rev.1
16. MSC.1/Circ.1549
17. MSC.1/Circ.1555
18. MSC.1/Circ.1561

**ANNEX 1**

**RESOLUTION MSC.409(97)  
(adopted on 25 November 2016)**

**AMENDMENTS TO THE INTERNATIONAL CONVENTION  
FOR THE SAFETY OF LIFE AT SEA, 1974, AS AMENDED**

THE MARITIME SAFETY COMMITTEE,

RECALLING Article 28(b) of the Convention on the International Maritime Organization concerning the functions of the Committee,

RECALLING ALSO Article VIII(b) of the International Convention for the Safety of Life at Sea, 1974 ("the Convention"), concerning the amendment procedure applicable to the annex to the Convention, other than to the provisions of chapter I,

HAVING CONSIDERED, at its ninety-seventh session, amendments to the Convention proposed and circulated in accordance with Article VIII(b)(i) of the Convention,

1 ADOPTS, in accordance with Article VIII(b)(iv) of the Convention, amendments to the Convention the text of which is set out in the annex to the present resolution;

2 DETERMINES, in accordance with Article VIII(b)(vi)(2)(bb) of the Convention, that the said amendments shall be deemed to have been accepted on 1 July 2019, unless, prior to that date, more than one third of the Contracting Governments to the Convention or Contracting Governments the combined merchant fleets of which constitute not less than 50% of the gross tonnage of the world's merchant fleet, have notified the Secretary-General of their objections to the amendments;

3 INVITES Contracting Governments to the Convention to note that, in accordance with Article VIII(b)(vii)(2) of the Convention, the amendments shall enter into force on 1 January 2020 upon their acceptance in accordance with paragraph 2 above;

4 REQUESTS the Secretary-General, for the purposes of Article VIII(b)(v) of the Convention, to transmit certified copies of the present resolution and the text of the amendments contained in the annex to all Contracting Governments to the Convention;

5 REQUESTS ALSO the Secretary-General to transmit copies of this resolution and its annex to Members of the Organization which are not Contracting Governments to the Convention.

ANNEX

**AMENDMENTS TO THE INTERNATIONAL CONVENTION FOR THE  
SAFETY OF LIFE AT SEA, 1974, AS AMENDED**

**CHAPTER II-1  
CONSTRUCTION – STRUCTURE, SUBDIVISION AND STABILITY, MACHINERY AND  
ELECTRICAL INSTALLATIONS**

**PART A  
GENERAL**

**Regulation 3-12 – Protection against noise**

1 The existing paragraph 2.1 is amended to read as follows:

".1 contracted for construction before 1 July 2014 and the keels of which are laid or which are at a similar stage of construction on or after 1 January 2009; or"



**CHAPTER II-2  
CONSTRUCTION – FIRE PROTECTION, FIRE DETECTION  
AND FIRE EXTINCTION**

**PART A  
GENERAL**

**Regulation 1 – Application**

2 The following new paragraph is added after existing paragraph 2.8:

"2.9 Regulation 10.5.1.2.2, as amended by resolution MSC.409(97), applies to ships constructed before 1 January 2020, including those constructed before 1 July 2012."

**PART C  
SUPPRESSION OF FIRE**

**Regulation 10 – Firefighting**

3 In paragraph 5.1.2.2, the last sentence is replaced with the following:

"In the case of domestic boilers of less than 175 kW, or boilers protected by fixed water-based local application fire-extinguishing systems as required by paragraph 5.6, an approved foam-type extinguisher of at least 135 l capacity is not required."

**CHAPTER XI-1  
SPECIAL MEASURES TO ENHANCE MARITIME SAFETY**

4 The following new regulation 2-1 is inserted after existing regulation 2:

**"Regulation 2-1 – Harmonization of survey periods of cargo ships not subject to the ESP Code**

For cargo ships not subject to enhanced surveys under regulation XI-1/2, notwithstanding any other provisions, the intermediate and renewal surveys included in regulation I/10 may be carried out and completed over the corresponding periods as specified in the 2011 ESP Code, as may be amended, and the guidelines developed by the Organization\*, as appropriate.

---

\* Refer to Survey Guidelines under the harmonized system of survey and certification (HSSC), 2015, as adopted by the Assembly of the Organization by resolution A.1104(29), as may be amended."

\*\*\*

**ANNEX 3**

**RESOLUTION MSC.411(97)  
(adopted on 25 November 2016)**

**AMENDMENTS TO THE INTERNATIONAL CODE FOR THE  
CONSTRUCTION AND EQUIPMENT OF SHIPS CARRYING  
LIQUEFIED GASES IN BULK (IGC CODE)**

THE MARITIME SAFETY COMMITTEE,

RECALLING Article 28(b) of the Convention on the International Maritime Organization concerning the functions of the Committee,

NOTING resolution MSC.5(48), by which it adopted the International Code for the Construction and Equipment of Ships Carrying Liquefied Gases in Bulk ("the IGC Code"), which has become mandatory under chapter VII of the International Convention for the Safety of Life at Sea, 1974 ("the Convention"),

NOTING ALSO Article VIII(b) and regulation VII/11.1 of the Convention concerning the procedure for amending the IGC Code,

HAVING CONSIDERED, at its ninety-seventh session, amendments to the IGC Code proposed and circulated in accordance with Article VIII(b)(i) of the Convention,

1 ADOPTS, in accordance with Article VIII(b)(iv) of the Convention, amendments to the IGC Code, the text of which is set out in the annex to the present resolution;

2 DETERMINES, in accordance with Article VIII(b)(vi)(2)(bb) of the Convention, that the amendments shall be deemed to have been accepted on 1 July 2019 unless, prior to that date, more than one third of the Contracting Governments to the Convention or Contracting Governments the combined merchant fleets of which constitute not less than 50% of the gross tonnage of the world's merchant fleet, have notified their objections to the amendments;

3 INVITES Contracting Governments to note that, in accordance with Article VIII(b)(vii)(2) of the Convention, the amendments shall enter into force on 1 January 2020 upon their acceptance in accordance with paragraph 2 above;

4 REQUESTS the Secretary-General, for the purpose of Article VIII(b)(v) of the Convention, to transmit certified copies of the present resolution and the text of the amendments contained in the annex to all Contracting Governments to the Convention;

5 REQUESTS ALSO the Secretary-General to transmit copies of this resolution and its annex to Members of the Organization which are not Contracting Governments to the Convention.

ANNEX

**AMENDMENTS TO THE INTERNATIONAL CODE FOR THE  
CONSTRUCTION AND EQUIPMENT OF SHIPS CARRYING  
LIQUEFIED GASES IN BULK (IGC CODE)**

**CHAPTER 3  
SHIP ARRANGEMENTS**

**3.2 Accommodation, service and machinery spaces and control stations**

Existing paragraph 3.2.5 is replaced with the following:

"3.2.5 Windows and sidescuttles facing the cargo area and on the sides of the superstructures and deckhouses within the limits specified in 3.2.4, except wheelhouse windows, shall be constructed to "A-60" class. Sidescuttles in the shell below the uppermost continuous deck and in the first tier of the superstructure or deckhouse shall be of fixed (non-opening) type."

\*\*\*

**ANNEX 4**

**RESOLUTION MSC.412(97)  
(adopted on 25 November 2016)**

**AMENDMENTS TO THE INTERNATIONAL CODE ON THE ENHANCED PROGRAMME  
OF INSPECTIONS DURING SURVEYS OF BULK CARRIERS  
AND OIL TANKERS, 2011 (2011 ESP CODE)**

THE MARITIME SAFETY COMMITTEE,

RECALLING Article 28(b) of the Convention on the International Maritime Organization concerning the functions of the Committee,

NOTING resolution A.1049(27), by which the Assembly adopted the International Code on the Enhanced Programme of Inspections during Surveys of Bulk Carriers and Oil Tankers, 2011 ("the 2011 ESP Code"), which has become mandatory under chapter XI-1 of the International Convention for the Safety of Life at Sea, 1974 ("the Convention"),

NOTING ALSO Article VIII(b) and regulation XI-1/2 of the Convention concerning the procedure for amending the 2011 ESP Code,

HAVING CONSIDERED, at its ninety-seventh session, amendments to the 2011 ESP Code proposed and circulated in accordance with Article VIII(b)(i) of the Convention,

1 ADOPTS, in accordance with Article VIII(b)(iv) of the Convention, amendments to the 2011 ESP Code the text of which is set out in the annex to the present resolution;

2 DETERMINES, in accordance with Article VIII(b)(vi)(2)(bb) of the Convention, that the said amendments shall be deemed to have been accepted on 1 January 2018 unless, prior to that date, more than one third of the Contracting Governments to the Convention or Contracting Governments the combined merchant fleets of which constitute not less than 50% of the gross tonnage of the world's merchant fleet, have notified the Secretary-General of their objections to the amendments;

3 INVITES Contracting Governments to the Convention to note that, in accordance with Article VIII(b)(vii)(2) of the Convention, the amendments shall enter into force on 1 July 2018 upon their acceptance in accordance with paragraph 2 above;

4 REQUESTS the Secretary-General, for the purposes of Article VIII(b)(v) of the Convention, to transmit certified copies of the present resolution and the text of the amendments contained in the annex to all Contracting Governments to the Convention;

5 REQUESTS ALSO the Secretary-General to transmit copies of this resolution and its annex to Members of the Organization which are not Contracting Governments to the Convention.

ANNEX

**AMENDMENTS TO  
THE INTERNATIONAL CODE ON THE ENHANCED PROGRAMME OF INSPECTIONS  
DURING SURVEYS OF BULK CARRIERS AND OIL TANKERS, 2011 (2011 ESP CODE)**

**ANNEX A**

**CODE ON THE ENHANCED PROGRAMME OF INSPECTIONS DURING SURVEYS OF  
BULK CARRIERS**

**Part A**

**CODE ON THE ENHANCED PROGRAMME OF INSPECTIONS DURING SURVEYS OF  
BULK CARRIERS HAVING SINGLE-SIDE SKIN CONSTRUCTION**

- 1 Paragraph 1.5 is replaced with the following:

**"1.5 Thickness measurements and close-up surveys**

In any kind of survey, i.e. renewal, intermediate, annual or other surveys having the scope of the foregoing ones, for structures in areas where close-up surveys are required, thickness measurements, when required by annex 2, should be carried out simultaneously with close-up surveys."

- 2 Paragraph 2.4.4 is replaced with the following:

"2.4.4 Close up survey and thickness measurement<sup>3</sup> of the hatch cover and coaming plating and stiffeners should be carried out as given in annexes 1 and 2.

---

<sup>3</sup> Subject to cargo hold hatch covers of approved design which structurally have no access to the internals, close-up survey/thickness measurement shall be done of accessible parts of hatch covers' structures."

ANNEX 1

**REQUIREMENTS FOR CLOSE-UP SURVEY AT RENEWAL SURVEYS**

- 3 Note (D) is replaced with the following:

"(D) Cargo hold hatch covers and coamings. For cargo hold hatch covers of approved design which structurally have no access to the internals, close-up survey/thickness measurement shall be done of accessible parts of hatch covers' structures."

## Part B

### CODE ON THE ENHANCED PROGRAMME OF INSPECTIONS DURING SURVEYS OF BULK CARRIERS HAVING DOUBLE-SIDE SKIN CONSTRUCTION

- 4 Paragraph 1.5 is replaced with the following:

**"1.5 Thickness measurements and close-up surveys**

In any kind of survey, i.e. renewal, intermediate, annual or other surveys having the scope of the foregoing ones, for structures in areas where close-up surveys are required, thickness measurements, when required by annex 2, should be carried out simultaneously with close-up surveys."

- 5 Paragraph 2.4.4 is replaced with the following:

"2.4.4 Close up survey and thickness measurement<sup>3</sup> of the hatch cover and coaming plating and stiffeners should be carried out as given in annexes 1 and 2.

---

<sup>3</sup> For cargo hold hatch covers of approved design which structurally have no access to the internals, close-up survey/thickness measurement shall be done of accessible parts of hatch covers' structures."

## ANNEX 1

### REQUIREMENTS FOR CLOSE-UP SURVEY AT RENEWAL SURVEYS

#### ***Appendix 1 – Minimum requirements for close-up survey at renewal survey of double-side skin bulk carriers excluding ore carriers***

##### **5 < Age ≤ 10 years – Renewal Survey No.2**

- 6 The third paragraph in the column is replaced with the following:

"25% of ordinary transverse frames for transverse framing systems or 25% of longitudinals for longitudinal framing systems on side shell and inner side plating at forward, middle and aft parts in the foremost double-side tanks. (B)"

##### **10 < Age ≤ 15 years – Renewal Survey No.3**

- 7 The third paragraph in the column is replaced with the following:

"25% of ordinary transverse frames for transverse framing systems or 25% of longitudinals for longitudinal framing systems on side shell and inner side plating at forward, middle and aft parts in all double-side tanks. (B)"

### **Age > 15 years – Renewal Survey No.4 and Subsequent**

8 The third paragraph in the column is replaced with the following:

"All ordinary transverse frames for transverse framing systems or all longitudinals for longitudinal framing systems on side shell and inner side plating at forward, middle and aft parts in all double-side tanks. (B)"

9 Note (D) is replaced with the following:

"(D) Cargo hold hatch covers and coamings. For cargo hold hatch covers of approved design which structurally have no access to the internals, close-up survey/thickness measurement shall be done of accessible parts of hatch covers' structures."

### **Appendix 2 – Minimum requirements for close-up survey at renewal survey for ore carriers**

10 Note (D) is replaced with the following:

"(D) Cargo hold hatch covers and coamings. For cargo hold hatch covers of approved design which structurally have no access to the internals, close-up survey/thickness measurement shall be done of accessible parts of hatch covers' structures."

## ANNEX 2

### **REQUIREMENTS FOR THICKNESS MEASUREMENTS AT RENEWAL SURVEYS**

#### **5 < Age ≤ 10 years – Renewal Survey No.2**

11 Paragraph 3 is replaced with the following:

"3 Measurement, for general assessment and recording of corrosion pattern, of those structural members subject to close-up survey according to annex 1/appendix 1 or annex 1/appendix 2 as applicable."

#### **10 < Age ≤ 15 years – Renewal Survey No.3**

12 Paragraph 3 is replaced with the following:

"3 Measurement, for general assessment and recording of corrosion pattern, of those structural members subject to close-up survey according to annex 1/appendix 1 or annex 1/appendix 2 as applicable."



## ANNEX B

### CODE ON THE ENHANCED PROGRAMME OF INSPECTIONS DURING SURVEYS OF OIL TANKERS

#### Part A

### CODE ON THE ENHANCED PROGRAMME OF INSPECTIONS DURING SURVEYS OF DOUBLE-HULL OIL TANKERS

13 Paragraph 1.5 is replaced with the following:

**"1.5 Thickness measurements and close-up surveys**

In any kind of survey, i.e. renewal, intermediate, annual or other surveys having the scope of the foregoing ones, for structures in areas where close-up surveys are required, thickness measurements, when required by annex 2, should be carried out simultaneously with close-up surveys."

14 Paragraph 2.5.6 is replaced with the following:

"2.5.6 In cases where two or three sections are to be measured, at least one should include a ballast tank within 0.5L amidships. In case of oil tankers of 130 m in length and upwards (as defined in the International Convention on Load Lines in force) and more than 10 years of age, for the evaluation of the ship's longitudinal strength as required in 8.1.2, the sampling method of thickness measurements is given in annex 12."

15 Paragraph 2.6.1.1 is replaced with the following:

".1 tank testing procedure, specifying fill heights, tanks being filled and bulkheads being tested, has been submitted by the owner and reviewed by the Administration or recognized organization prior to the testing being carried out;"

## ANNEX 1

### MINIMUM REQUIREMENTS FOR CLOSE-UP SURVEY AT RENEWAL SURVEY OF DOUBLE-HULL OIL TANKERS

16 Note (7) is replaced with the following:

"(7) Web frame in a cargo oil tank means deck transverse, longitudinal bulkhead structural elements and cross ties, where fitted, including adjacent structural members."

**Part B**

**CODE ON THE ENHANCED PROGRAMME OF INSPECTIONS  
DURING SURVEYS OF OIL TANKERS OTHER THAN  
DOUBLE-HULL OIL TANKERS**

17 Paragraph 1.5 is replaced with the following:

**"1.5 Thickness measurements and close-up surveys**

In any kind of survey, i.e. renewal, intermediate, annual or other surveys having the scope of the foregoing ones, for structures in areas where close-up surveys are required, thickness measurements, when required by annex 2, should be carried out simultaneously with close-up surveys."

18 Paragraph 2.6.1.1 is replaced with the following:

".1 tank testing procedure, specifying fill heights, tanks being filled and bulkheads being tested, has been submitted by the owner and reviewed by the Administration or recognized organization prior to the testing being carried out;"

\*\*\*

**ANNEX 5**

**RESOLUTION MSC.413(97)  
(adopted on 25 November 2016)**

**AMENDMENTS TO THE INTRODUCTION AND PART A OF THE INTERNATIONAL  
CODE ON INTACT STABILITY, 2008 (2008 IS CODE)**

THE MARITIME SAFETY COMMITTEE,

RECALLING Article 28(b) of the Convention on the International Maritime Organization concerning the functions of the Committee,

RECALLING ALSO resolution MSC.267(85) by which it adopted the International Code on Intact Stability, 2008 ("2008 IS Code"),

NOTING the provisions regarding the procedure for amendments to the introduction and part A of the 2008 IS Code, stipulated in regulation II-1/2.27.1 of the International Convention for the Safety of Life at Sea, 1974 ("the Convention"), as amended by resolution MSC.269(85),

RECOGNIZING the need to include provisions regarding ships engaged in anchor handling, lifting and towing operations, including escort towing, in the 2008 IS Code,

HAVING CONSIDERED, at its ninety-seventh session, the amendments to the introduction and part A of the 2008 IS Code, proposed and circulated in accordance with Article VIII(b)(i) of the Convention,

1 ADOPTS, in accordance with Article VIII(b)(iv) of the Convention, amendments to the introduction and part A of the 2008 IS Code, the text of which is set out in the annex to the present resolution;

2 DETERMINES, in accordance with Article VIII(b)(vi)(2)(bb) of the Convention, that the said amendments shall be deemed to have been accepted on 1 July 2019, unless, prior to that date, more than one third of the Contracting Governments to the Convention, or Contracting Governments the combined merchant fleets of which constitute not less than 50% of the gross tonnage of the world's merchant fleet, have notified the Secretary-General of the Organization of their objections to the amendments;

3 INVITES Contracting Governments to the Convention to note that, in accordance with Article VIII(b)(vii)(2) of the Convention, the amendments shall enter into force on 1 January 2020 upon their acceptance in accordance with paragraph 2 above;

4 REQUESTS the Secretary-General of the Organization, for the purposes of Article VIII(b)(v) of the Convention, to transmit certified copies of the present resolution and the text of the amendments contained in the annex to all Contracting Governments to the Convention;

5 REQUESTS ALSO the Secretary-General of the Organization to transmit copies of this resolution and its annex to Members of the Organization which are not Contracting Governments to the Convention.

## ANNEX

### AMENDMENTS TO THE INTRODUCTION AND PART A OF THE INTERNATIONAL CODE ON INTACT STABILITY, 2008 (2008 IS CODE)

#### INTRODUCTION

##### 1 Purpose

1 The chapeau of paragraph 1.2 is replaced with the following:

"1.2 Unless otherwise stated, this Code contains intact stability criteria applicable to ships and other marine vehicles of 24 m in length and above, as listed below. The Code also provides intact stability criteria applicable to the same ships and marine vehicles when engaged in certain operations:"

2 In paragraph 1.2, the following new subparagraphs .7 to .9 are inserted after the existing subparagraph .6:

.7 ships engaged in anchor handling operations;

.8 ships engaged in harbour, coastal or ocean-going towing operations and escort operations;

.9 ships engaged in lifting operations;"

and the remaining subparagraphs are renumbered accordingly.

##### 2 Definitions

3 The following new paragraphs 2.27 to 2.31 are inserted after the existing paragraph 2.26:

"2.27 *Ship engaged in anchor handling operations* means a ship engaged in operations with deployment, recovering and repositioning of anchors and the associated mooring lines of rigs or other vessels. Forces associated with anchor handling are generally associated with the winch line pull and may include vertical, transverse, and longitudinal forces applied at the towing point and over the stern roller.

2.28 *Ship engaged in harbour towing* means a ship engaged in an operation intended for assisting ships or other floating structures within sheltered waters, normally while entering or leaving port and during berthing or unberthing operations.

2.29 *Ship engaged in coastal or ocean-going towing* means a ship engaged in an operation intended for assisting ships or other floating structures outside sheltered waters in which the forces associated with towing are often a function of the ship's bollard pull.\*

2.30 *Ship engaged in lifting operation* means a ship engaged in an operation involving the raising or lowering of objects using vertical force by means of winches, cranes, a-frames or other lifting devices.\*\*

2.31 *Ship engaged in escort operation* means a ship specifically engaged in steering, braking and otherwise controlling of the assisted ship during ordinary or emergency manoeuvring, whereby the steering and braking forces are generated by the hydrodynamic forces acting on the hull and appendages and the thrust forces exerted by the propulsion units (see also figure 1).

---

\* Refer to the *Guidelines for safe ocean towing* (MSC/Circ.884).

\*\* Fishing vessels should not be included in the definition of lifting operations. Reference is made to paragraphs 2.1.2.2 and 2.1.2.8 of chapter 2 of part B. For anchor handling operations reference is made to section 2.7 of chapter 2 of part B."

## **PART A MANDATORY CRITERIA**

4 The following footnote is added to the existing title of chapter 2:

"\* Paragraphs 3.4.1.8, 3.4.1.9, 3.6.4 and 3.6.5 in part B should only be considered as recommendations."

\*\*\*

**ANNEX 6**

**RESOLUTION MSC.414(97)  
(adopted on 25 November 2016)**

**AMENDMENTS TO THE INTRODUCTION AND PART A OF THE INTERNATIONAL  
CODE ON INTACT STABILITY, 2008 (2008 IS CODE)**

THE MARITIME SAFETY COMMITTEE,

RECALLING Article 28(b) of the Convention on the International Maritime Organization concerning the functions of the Committee,

RECALLING ALSO resolution MSC.267(85) by which it adopted the International Code on Intact Stability, 2008 ("2008 IS Code"),

NOTING the provisions regarding the procedure for amendments to the introduction and part A of the 2008 IS Code, stipulated in paragraph (16).1 of regulation I/3 of the Protocol of 1988 relating to the International Convention on Load Lines, 1966 ("1988 Load Lines Protocol"), as amended by resolution MSC.270(85),

RECOGNIZING the need to include provisions regarding ships engaged in anchor handling, lifting and towing operations, including escort towing, in the 2008 IS Code,

HAVING CONSIDERED, at its ninety-seventh session, amendments to the introduction and part A of the 2008 IS Code, proposed and circulated in accordance with paragraph 2(a) of Article VI of the 1988 Load Lines Protocol,

1 ADOPTS, in accordance with paragraph 2(d) of Article VI of the 1988 Load Lines Protocol, amendments to the introduction and part A of the 2008 IS Code, the text of which is set out in the annex to the present resolution;

2 DETERMINES, in accordance with paragraph 2(f)(ii)(bb) of Article VI of the 1988 Load Lines Protocol, that the said amendments shall be deemed to have been accepted on 1 July 2019, unless, prior to that date, more than one third of the Parties to the 1988 Load Lines Protocol, or Parties the combined merchant fleets of which constitute not less than 50% of all the merchant fleets of all Parties, have notified the Secretary-General of the Organization of their objections to the amendments;

3 INVITES Parties to the 1988 Load Lines Protocol to note that, in accordance with paragraph 2(g)(ii) of Article VI of the 1988 Load Lines Protocol, the amendments shall enter into force on 1 January 2020 upon their acceptance in accordance with paragraph 2 above;

4 REQUESTS the Secretary-General of the Organization, for the purposes of paragraph 2(e) of Article VI of the 1988 Load Lines Protocol, to transmit certified copies of the present resolution and the text of the amendments contained in the annex to all Parties to the 1988 Load Lines Protocol;

5 REQUESTS ALSO the Secretary-General of the Organization to transmit copies of this resolution and its annex to Members of the Organization, which are not Parties to the 1988 Load Lines Protocol.

ANNEX

**AMENDMENTS TO THE INTRODUCTION AND PART A OF THE INTERNATIONAL  
CODE ON INTACT STABILITY, 2008 (2008 IS CODE)**

**INTRODUCTION**

**1 Purpose**

1 The chapeau of paragraph 1.2 is replaced with the following:

"1.2 Unless otherwise stated, this Code contains intact stability criteria applicable to ships and other marine vehicles of 24 m in length and above, as listed below. The Code also provides intact stability criteria applicable to the same ships and marine vehicles when engaged in certain operations:"

2 In paragraph 1.2, the following new subparagraphs .7 to .9 are inserted after the existing subparagraph .6:

.7 ships engaged in anchor handling operations;

.8 ships engaged in harbour, coastal or ocean-going towing operations and escort operations;

.9 ships engaged in lifting operations;"

and the remaining subparagraphs are renumbered accordingly.

**2 Definitions**

3 The following new paragraphs 2.27 to 2.31 are inserted after the existing paragraph 2.26:

"2.27 *Ship engaged in anchor handling operations* means a ship engaged in operations with deployment, recovering and repositioning of anchors and the associated mooring lines of rigs or other vessels. Forces associated with anchor handling are generally associated with the winch line pull and may include vertical, transverse, and longitudinal forces applied at the towing point and over the stern roller.

2.28 *Ship engaged in harbour towing* means a ship engaged in an operation intended for assisting ships or other floating structures within sheltered waters, normally while entering or leaving port and during berthing or unberthing operations.

2.29 *Ship engaged in coastal or ocean-going towing* means a ship engaged in an operation intended for assisting ships or other floating structures outside sheltered waters in which the forces associated with towing are often a function of the ship's bollard pull.\*

2.30 *Ship engaged in lifting operation* means a ship engaged in an operation involving the raising or lowering of objects using vertical force by means of winches, cranes, a-frames or other lifting devices.\*\*

\* Refer to the *Guidelines for safe ocean towing* (MSC/Circ.884).

\*\* Fishing vessels should not be included in the definition of lifting operations. Reference is made to paragraphs 2.1.2.2 and 2.1.2.8 of chapter 2 of part B. For anchor handling operations reference is made to section 2.7 of chapter 2 of part B.

2.31 *Ship engaged in escort operation* means a ship specifically engaged in steering, braking and otherwise controlling of the assisted ship during ordinary or emergency manoeuvring, whereby the steering and braking forces are generated by the hydrodynamic forces acting on the hull and appendages and the thrust forces exerted by the propulsion units (see also figure 1)."

**PART A**  
**MANDATORY CRITERIA**

4 The following footnote is added to the existing title of chapter 2:

"\* Paragraphs 3.4.1.8, 3.4.1.9, 3.6.4 and 3.6.5 in part B should only be considered as recommendations."

\*\*\*



**ANNEX 7**

**RESOLUTION MSC.415(97)  
(adopted on 25 November 2016)**

**AMENDMENTS TO PART B OF THE INTERNATIONAL  
CODE ON INTACT STABILITY, 2008 (2008 IS CODE)**

THE MARITIME SAFETY COMMITTEE,

RECALLING Article 28(b) of the Convention on the International Maritime Organization concerning the functions of the Committee,

RECALLING ALSO resolution MSC.267(85) by which it adopted the International Code on Intact Stability, 2008 ("2008 IS Code"),

NOTING the provisions regarding the procedure for amendments to part B of the 2008 IS Code, stipulated in regulation II-1/2.27.2 of the International Convention for the Safety of Life at Sea, 1974 ("the SOLAS Convention"), as amended by resolution MSC.269(85), and in paragraph (16).2 of regulation I/3 of the Protocol of 1988 relating to the International Convention on Load Lines, 1966 ("1988 Load Lines Protocol"), as amended by resolution MSC.270(85),

RECOGNIZING the need to include provisions regarding ships engaged in anchor handling, lifting and towing operations, including escort towing, in the 2008 IS Code,

HAVING CONSIDERED, at its ninety-seventh session, the proposed amendments to part B of the 2008 IS Code, prepared by the Sub-Committee on Ship Design and Construction, at its second session,

- 1 ADOPTS amendments to part B of the 2008 IS Code, the text of which is set out in the annex to the present resolution;
- 2 RECOMMENDS Governments concerned to use the amendments to part B of the 2008 IS Code as a basis for relevant safety standards, unless their national stability requirements provide at least an equivalent degree of safety;
- 3 INVITES Contracting Governments to the SOLAS Convention and Parties to the 1988 Load Lines Protocol to note that the above amendments to the 2008 IS Code will take effect on 1 January 2020.

ANNEX

**AMENDMENTS TO PART B OF THE 2008 IS CODE**

- 1 The title of part B is replaced with the following text:

**"Part B**

*Recommendations for ships engaged in certain types of operations, certain types of ships and additional guidelines"*

**Chapter 1 – General**

**1.2 Application**

- 2 A new paragraph 1.2.2 is inserted after the existing paragraph 1.2.1 as follows:

"1.2.2 The recommendations contained herein may also apply to other ships subject to similar external forces, when determining the adequacy of stability."

and the existing paragraphs 1.2.2 and 1.2.3 are renumbered accordingly.

**Chapter 2 – Recommended design criteria for certain types of ships**

- 3 The title of chapter 2 is replaced with the following:

**"Recommended design criteria for ships engaged in certain types of operations and certain types of ships"**

- 4 Paragraph 2.4.3.4 is replaced with the following:

"2.4.3.4 A vessel engaged in towing operations should be provided with means for quick release of the towline.\*"

---

\* Vessels provided with towing winch systems should also be provided with means of quick release."

- 5 The following new sections 2.7 to 2.9 are added after existing section 2.6:

**"2.7 Ships engaged in anchor handling operations**

**2.7.1 Application**

2.7.1.1 The provisions given hereunder apply to ships engaged in anchor handling operations.

2.7.1.2 A *wire* means a dedicated line (wire rope, synthetic rope or chain cable) used for the handling of anchors by means of an anchor handling winch.

## 2.7.2 Heeling levers

2.7.2.1 A heeling lever,  $HL_\varphi$ , generated by the action of a heeling moment caused by the vertical and horizontal components of the tension applied to the wire should be calculated as:

$$HL_\varphi = (M_{AH} / \Delta_2) \cos \varphi$$

where:

$$M_{AH} = F_p \times (h \sin \alpha \times \cos \beta + y \times \sin \beta);$$

$\Delta_2$  = displacement of a loading condition, including action of the vertical loads added ( $F_v$ ), at the centreline in the stern of ship;

$$F_v = F_p \times \sin \beta;$$

$\alpha$  = the horizontal angle between the centreline and the vector at which the wire tension is applied to the ship in the upright position, positive outboard;

$\beta$  = the vertical angle between the waterplane and the vector at which the wire tension is applied to the ship, positive downwards, should be taken at the maximum heeling moment angle as  $\tan^{-1}(y / (h \times \sin \alpha))$ , but not less than  $\cos^{-1}(1.5 B_P / (F_P \cos \alpha))$ , using consistent units;

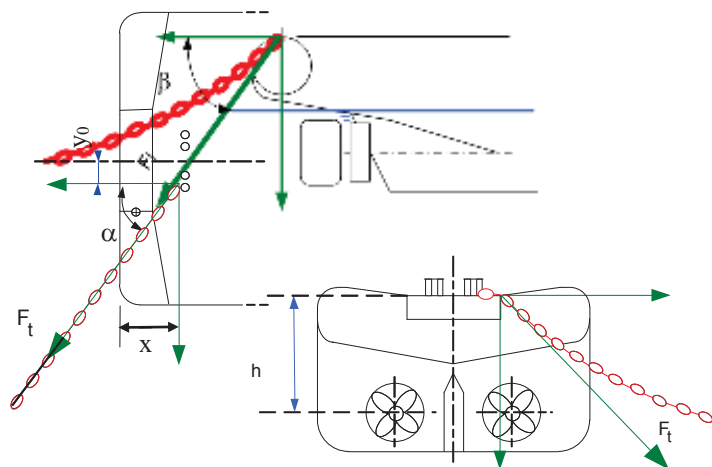

**Figure 2.7-1 – Diagrams showing the intended meaning of parameters  $\alpha$ ,  $\beta$ ,  $x$ ,  $y$  and  $h$ .  $F_t$  shows the vector of the applied wire tension.**

$B_P$  = the Bollard pull that is the documented maximum continuous pull obtained from a static pull test on sea trial, carried out in accordance with annex A of MSC/Circ.884 or an equivalent standard acceptable to the Administration;

$F_p$	=	(Permissible tension) the wire tension which can be applied to the ship as loaded while working through a specified tow pin set, at each $\alpha$ , for which all stability criteria can be met. $F_p$ should in no circumstance be taken as greater than $F_d$ ;
$F_d$	=	(Design maximum wire tension) the maximum winch wire pull or maximum static winch brake holding force, whichever is greater;
$h$	=	the vertical distance (m) from the centre the propulsive force acts on the ship to either: <ul style="list-style-type: none"><li>• the uppermost part at the towing pin, or</li><li>• a point on a line defined between the highest point of the winch pay-out and the top of the stern or any physical restriction of the transverse wire movement;</li></ul>
$y$	=	the transverse distance (m) from the centreline to the outboard point at which the wire tension is applied to the ship given by:  $y_0 + x \tan \alpha$ ; but not greater than $B/2$ ;
$B$	=	the moulded breadth (m);
$y_0$	=	the transverse distance (m) between the ship centreline to the inner part of the towing pin or any physical restriction of the transverse wire movement;
$x$	=	the longitudinal distance (m) between the stern and the towing pin or any physical restriction of the transverse wire movement.

### 2.7.3 Permissible tension

2.7.3.1 The permissible tension as function of  $\alpha$ , defined in paragraph 2.7.2, should not be greater than the tension given by paragraph 2.7.3.2,

2.7.3.2 Permissible tension as function of  $\alpha$  can be calculated by direct stability calculations, provided that the following are met:

- .1 the heeling lever should be taken as defined in paragraph 2.7.2 for each  $\alpha$ ;
- .2 the stability criteria in paragraph 2.7.4, should be met;
- .3  $\alpha$  should not be taken less than 5 degrees, except as permitted by paragraph 2.7.3.3; and
- .4 Intervals of  $\alpha$  should not be more than 5 degrees, except that larger intervals may be accepted, provided that the permissible tension is limited to the higher  $\alpha$  by forming working sectors.

2.7.3.3 For the case of a planned operation to retrieve a stuck anchor in which the ship is on station above the anchor and the ship has low or no speed,  $\alpha$  may be taken as less than 5 degrees.

#### **2.7.4 Stability criteria**

2.7.4.1 For the loading conditions intended for anchor handling, but before commencing the operation, the stability criteria given in paragraph 2.2 of part A, or where a ship's characteristics render compliance with paragraph 2.2 of part A impracticable, the equivalent stability criteria given in paragraph 2.4 of part B, should apply. During operation, under the action of the heeling moment, the criteria under paragraphs 2.7.4.2 to 2.7.4.4 should apply.

2.7.4.2 The residual area between the righting lever curve and the heeling lever curve calculated in accordance with paragraph 2.7.2 should not be less than 0.070 metre-radians. The area is determined from the first intersection of the two curves,  $\varphi_e$ , to the angle of the second intersection,  $\varphi_c$ , or the angle of down-flooding,  $\varphi_f$ , whichever is less.

2.7.4.3 The maximum residual righting lever GZ between the righting lever curve and the heeling lever curve calculated in accordance with paragraph 2.7.2 should be at least 0.2 m.

2.7.4.4 The static angle at the first intersection,  $\varphi_e$ , between the righting lever curve and the heeling lever curve calculated in accordance with paragraph 2.7.2 should not be greater than:

- .1 the angle at which the righting lever equals 50% of the maximum righting lever;
- .2 the deck edge immersion angle; or
- .3 15°,

whichever is less.

2.7.4.5 A minimum freeboard at stern, on centreline, of at least 0.005L should be maintained in all operating conditions, with a displacement given by  $\Delta_2$ , as defined in paragraph 2.7.2. In the case of the anchor retrieval operation covered by paragraph 2.7.3.3, a lower minimum freeboard may be accepted provided that due consideration has been given to this in the operation plan.

#### **2.7.5 Constructional precautions against capsizing**

2.7.5.1 A stability instrument may be used for determining the permissible tension and checking compliance with relevant stability criteria.

Two types of stability instrument may be used on board:

- either a software checking the intended or actual tension on the basis of the permissible tension curves; or

- a software performing direct stability calculations to check compliance with the relevant criteria, for a given loading condition (before application of the tension force), a given tension and a given wire position (defined by angles  $\alpha$  and  $\beta$ ).

2.7.5.2 Access to the machinery space, excluding emergency access and removal hatches, should, if possible, be arranged within the forecastle. Any access to the machinery space from the exposed cargo deck should be provided with two weathertight closures. Access to spaces below the exposed cargo deck should preferably be from a position within or above the superstructure deck.

2.7.5.3 The area of freeing ports in the side bulwarks of the cargo deck should at least meet the requirements of regulation 24 of the International Convention on Load Lines, 1966 or the Protocol of 1988 relating thereto, as amended, as applicable. The disposition of the freeing ports should be carefully considered to ensure the most effective drainage of water trapped in working deck and in recesses at the after end of the forecastle. In ships operating in areas where icing is likely to occur, no shutters should be fitted in the freeing ports.

2.7.5.4 The winch systems should be provided with means of emergency release.

2.7.5.5 For ships engaged in anchor handling operations the following recommendations for the anchor handling arrangements should be considered:

- .1 stop pins or other design features meant to impede the movement of the wire further outboard should be installed; and
- .2 the working deck should be marked with contrasting colours or other identifiers such as guide pins, stop pins or similar easily identifiable points that identify operational zones for the line to aid operator observation.

### **2.7.6 Operational procedures against capsizing**

2.7.6.1 A comprehensive operational plan should be defined for each anchor handling operation, according to the guidelines given in paragraph 3.8, where at least, but not only, the following procedures and emergency measures should be identified:

- .1 environmental conditions for the operation;
- .2 winch operations and movements of weights;
- .3 compliance with the stability criteria, for the different expected loading conditions;
- .4 permissible tensions on the winches as function of  $\alpha$ ; in accordance with paragraph 3.8;
- .5 stop work and corrective procedures; and
- .6 confirmation of the master's duty to take corrective action when necessary.

2.7.6.2 The arrangement of cargo stowed on deck should be such as to avoid any obstruction of the freeing ports or sudden shift of cargo on deck.

2.7.6.3 Counter-ballasting to correct the list of the ship during anchor handling operations should be avoided.

## 2.8 Ships engaged in towing and escort operations

### 2.8.1 Application

The provisions given hereunder apply to ships the keel of which is laid or which is at a similar stage of construction\* on or after 1 January 2020 engaged in harbour towing, coastal or ocean-going towing and escort operations and to ships converted to carry out towing operations after this date.

- \* A similar stage of construction means the stage at which:
- .1 construction identifiable with a specific ship begins; and
  - .2 assembly of that ship has commenced, comprising at least 50 tonnes or 1% of the estimated mass of all structural material, whichever is less.

### 2.8.2 Heeling lever for towing operations

2.8.2.1 The self-tripping heeling lever is calculated as provided below:

- .1 A transverse heeling moment is generated by the maximum transverse thrust exerted by the ship's propulsion and steering systems and the corresponding opposing towline pull.
- .2 The heeling lever  $HL_\varphi$ , in (m), as a function of the heeling angle  $\varphi$ , should be calculated according to the following formula:

$$HL_\varphi = \frac{BP \times C_T \times (h \times \cos \varphi - r \times \sin \varphi)}{g \times \Delta}$$

where:

$BP$  = bollard pull, in (kN), which is the documented maximum continuous pull obtained from a static bollard pull test performed in accordance with relevant IMO guidelines\* or a standard acceptable to the Administration;

\* Refer to annex A to the *Guidelines for safe ocean towing* (MSC/Circ.884).

- $C_T =$
- 0.5, for ships with conventional, non-azimuth propulsion units;
  - $0.90/(1 + //L_{LL})$ , for ships with azimuth propulsion units installed at a single point along the length. However,  $C_T$  should not be less than 0.7 for ships with azimuth stern drive towing over the stern or tractor tugs towing over the bow, and not less than 0.5 for ships with azimuth stern drive towing over the bow or tractor tugs towing over the stern;

For tugs with other propulsion and/or towing arrangements, the value of  $C_T$  is to be established on a case by case basis to the satisfaction of the Administration.

- $\Delta$  = displacement, in (t);
- $l$  = longitudinal distance, in (m), between the towing point and the vertical centreline of the propulsion unit(s) relevant to the towing situation considered;
- $h$  = vertical distance, in (m), between the towing point and the horizontal centreline of the propulsion unit(s) as relevant for the towing situation considered;
- $g$  = gravitational acceleration, in (m/s<sup>2</sup>), to be taken as 9.81;
- $r$  = the transverse distance, in (m), between the centre line and the towing point, to be taken as zero when the towing point is at the centre line.
- $L_{LL}$  = length (L) as defined in the International Convention on Load Lines in force.

The towing point is the location where the towline force is applied to the ship. The towing point may be a towing hook, staple, fairlead or equivalent fitting serving that purpose.

2.8.2.2 The tow-tripping heeling lever  $HL_\varphi$ , in (m), is calculated according to the following formula:

$$HL_\varphi = C_1 \times C_2 \times \gamma \times V^2 \times A_P \times (h \times \cos \varphi - r \times \sin \varphi + C_3 \times d) / (2 \times g \times \Delta)$$

where:

$$C_1 = \text{lateral traction coefficient} = \frac{2.8 \left( \frac{L_s}{L_{PP}} - 0.1 \right)}{L_{PP}} \quad 0.10 \leq C_1 \leq 1.00$$

$$C_2 = \text{correction of } C_1 \text{ for angle of heel} = \left( \frac{\varphi}{3 \cdot \varphi_D} + 0.5 \right) \quad C_2 \geq 1.00$$

$$\text{Angle to deck edge} \quad \varphi_D = \arctan\left(\frac{2f}{B}\right)$$

$C_3$  = distance from the centre of  $A_P$  to the waterline as fraction of the draught related to the heeling angle

$$C_3 = \left( \frac{\varphi}{\varphi_D} \right) \times 0.26 + 0.30 \quad 0.50 \leq C_3 \leq 0.83$$

$\gamma$  = specific gravity of water, in (t/m<sup>3</sup>);

$V$  = lateral velocity, in (m/s), to be taken as 2.57 (5 knots);



$A_P$  = lateral projected area, in (m<sup>2</sup>), of the underwater hull;  
 $r$  = the transverse distance, in (m), between the centre line and the towing point, to be taken as zero when the towing point is at the centre line;  
 $L_S$  = the longitudinal distance, in (m), from the aft perpendicular to the towing point;  
 $L_{PP}$  = length between perpendiculars, in (m);  
 $\varphi$  = angle of heel;  
 $f$  = freeboard amidship, in (m);  
 $B$  = moulded breadth, in (m);  
 $h$  = vertical distance, in (m), from the waterline to the towing point;  
 $d$  = actual mean draught, in (m).

The towing point is the location where the towline force is applied to the ship. The towing point may be a towing hook, staple, fairlead or equivalent fitting serving that purpose.

### **2.8.3 Heeling lever for escort operations**

2.8.3.1 For the evaluation of the stability particulars during escort operations the ship is considered to be in an equilibrium position determined by the combined action of the hydrodynamic forces acting on hull and appendages, the thrust force and the towline force as shown in figure 2.8-1.

2.8.3.2 For each equilibrium position the corresponding steering force, braking force, heel angle and heeling lever are to be obtained from the results of full scale trials, model tests, or numerical simulations in accordance with a methodology acceptable to the Administration.

2.8.3.3 For each relevant loading condition the evaluation of the equilibrium positions is to be performed over the applicable escort speed range, whereby the speed of the assisted ship through the water is to be considered.\*

---

\* The typical escort speed range is 6 to 10 knots.

2.8.3.4 For each relevant combination of loading condition and escort speed, the maximum heeling lever is to be used for the evaluation of the stability particulars.

2.8.3.5 For the purpose of stability calculations the heeling lever is to be taken as constant.

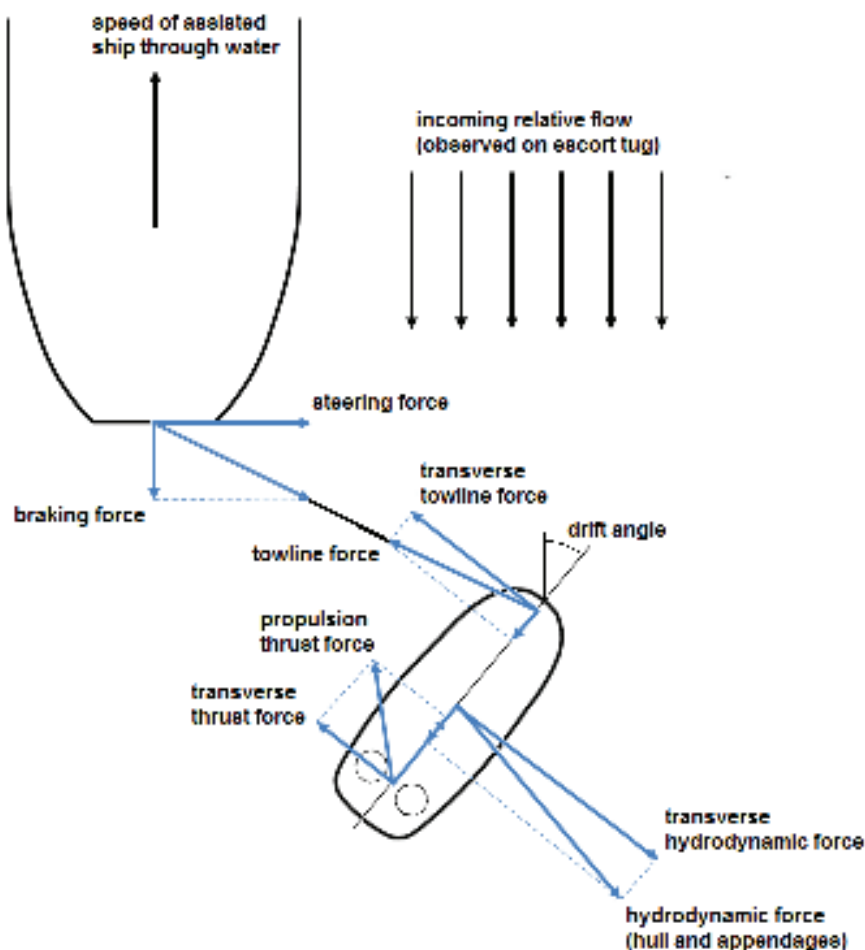

Figure 2.8-1: Escort tug equilibrium position

#### 2.8.4 Stability criteria

2.8.4.1 In addition to the stability criteria given in part A, section 2.2, or the equivalent stability criteria given in chapter 4 of the explanatory notes to the 2008 IS Code where the ship's characteristics render compliance with part A, section 2.2 impracticable, the following stability criteria should be complied with.

2.8.4.2 For ships engaged in harbour, coastal or ocean-going towing operations the area A contained between the righting lever curve and the heeling lever curve calculated in accordance with paragraph 2.8.2.1 (self-tripping), measured from the heel angle,  $\varphi_e$ , to the angle of the second intersection,  $\varphi_c$ , or the angle of down-flooding,  $\varphi_f$ , whichever is less, should be greater than the area B contained between the heeling lever curve and the righting lever curve, measured from the heel angle  $\varphi = 0$  to the heel angle,  $\varphi_e$ .

where:

$\varphi_e$  = Angle of first intersection between the heeling lever and righting lever curves;

- $\varphi_f$  = Angle of down-flooding as defined in part A, paragraph 2.3.1.4 of this Code. Openings required to be fitted with weathertight closing devices under the ICLL but, for operational reasons, are required to be kept open should be considered as down-flooding points in stability calculation;
- $\varphi_c$  = Angle of second intersection between the heeling lever and righting lever curves.

2.8.4.3 For ships engaged in harbour, coastal or ocean-going towing operations the first intersection between the righting lever curve and the heeling lever curve calculated in accordance with paragraph 2.8.2.2 (tow-tripping) should occur at an angle of heel less than the angle of down-flooding,  $\varphi_f$ .

2.8.4.4 For ships engaged in escort operations the maximum heeling lever determined in accordance with paragraph 2.8.3 should comply with the following criteria:

- .1 Area A  $\geq$  1.25  $\times$  Area B;
- .2 Area C  $\geq$  1.40  $\times$  Area D; and
- .3  $\varphi_e \leq$  15 degrees.

where:

- Area A = Righting lever curve area measured from the heel angle  $\varphi_e$  to a heel angle of 20 degrees (see figure 2.8-2);
- Area B = Heeling lever curve area measured from the heeling angle  $\varphi_e$  to a heel angle of 20 degrees (see figure 2.8-2);
- Area C = Righting lever curve area measured from the zero heel ( $\varphi = 0$ ) to  $\varphi_d$  (see figure 2.8-3);
- Area D = Heeling lever curve area measured from zero heel ( $\varphi = 0$ ) to the heeling angle  $\varphi_d$  (see figure 2.8-3);
- $\varphi_e$  = Equilibrium heel angle corresponding to the first intersection between heeling lever curve and the righting lever curve;
- $\varphi_d$  = the heel angle corresponding to the second intersection between heeling lever curve and the righting lever curve or the angle of down-flooding or 40 degrees, whichever is less.

Figure 2.8-2: Areas A and B

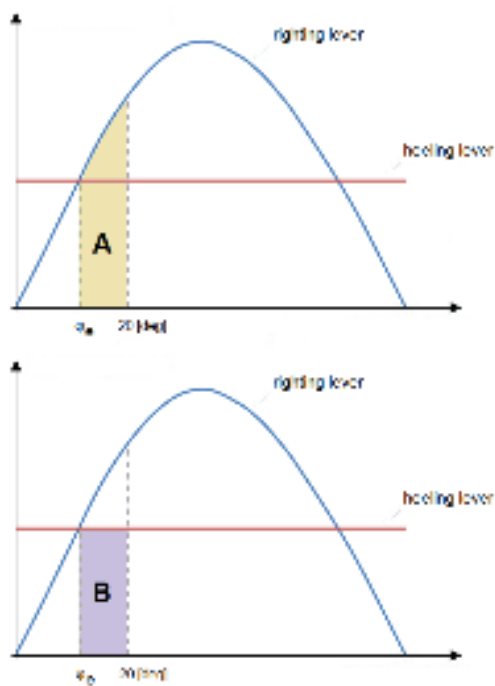
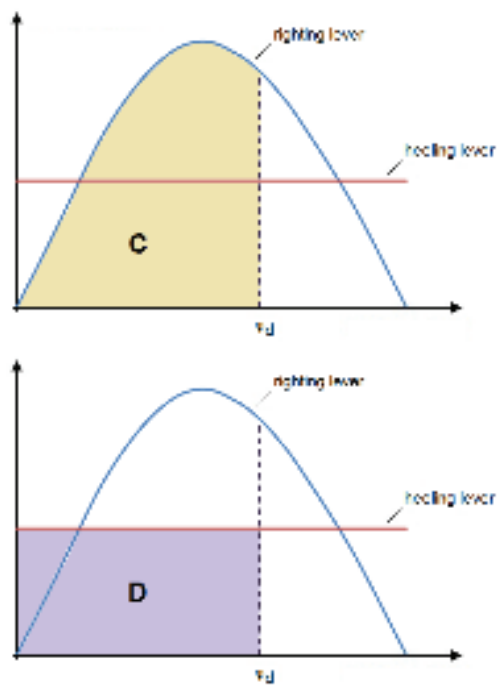

Figure 2.8-3: Areas C and D



### 2.8.5 *Constructional precautions against capsizing*

2.8.5.1 Access to the machinery space, excluding emergency access and removal hatches, should, if possible, be arranged within the forecastle. Any access to the machinery space from the exposed cargo deck should be provided with two weathertight closures, if practicable. Access to spaces below the exposed cargo deck should preferably be from a position within or above the superstructure deck.

2.8.5.2 The area of freeing ports in the side bulwarks of the cargo deck should at least meet the requirements of regulation 24 of the International Convention on Load Lines, 1966 or the Protocol of 1988 relating thereto, as amended, as applicable. The disposition of the freeing ports should be carefully considered to ensure the most effective drainage of water trapped on the working deck and in recesses at the after end of the forecastle. In ships operating in areas where icing is likely to occur, no shutters should be fitted in the freeing ports.

2.8.5.3 A ship engaged in towing operations should be provided with means for quick release of the towline.\*

\* Ships provided with towing winch systems should also be provided with means of quick release.

### 2.8.6 *Operational procedures against capsizing*

2.8.6.1 The arrangement of cargo stowed on deck should be such as to avoid any obstruction of the freeing ports or sudden shift of cargo on deck. Cargo on deck, if any, should not interfere with the movement of the towline.

2.8.6.2 A minimum freeboard at stern of at least  $0.005 \times L_{LL}$  should be maintained in all operating conditions.

## 2.9 Ships engaged in lifting operations

### 2.9.1 Application

2.9.1.1 The provisions given hereunder apply to ships the keel of which is laid or which is at a similar stage of construction\* on or after 1 January 2020 engaged in lifting operations and to ships converted to carry out lifting operations after this date.

- \* A similar stage of construction means the stage at which:
- .1 construction identifiable with a specific ship begins; and
  - .2 assembly of that ship has commenced, comprising at least 50 tonnes or 1% of the estimated mass of all structural material, whichever is less.

2.9.1.2 The provisions of this section should be applied to operations involving the lifting of the ship's own structures or for lifts in which the maximum heeling moment due to the lift is greater than that given in the following:

$$M_L = 0.67 \cdot \Delta \cdot GM \cdot \left( \frac{f}{B} \right)$$

where:

- $M_L$  = Threshold value for the heeling moment, in (t.m), induced by the (lifting equipment and) load in the lifting equipment;
- $GM$  = The initial metacentric height, in (m), with free surface correction, including the effect of the (lifting equipment and) load in the lifting equipment;
- $f$  = the minimum freeboard, in (m), measured from the upper side of the weather deck to the waterline;
- $B$  = the moulded breadth of the ship, in (m); and
- $\Delta$  = the displacement of the ship, including the lift load, in (t).

The provisions of this section also apply to ships which are engaged in lifting operations where no transverse heeling moment is induced and the increase of the ship's vertical centre of gravity (VCG) due to the lifted weight is greater than 1%.

The calculations should be completed at the most unfavourable loading conditions for which the lifting equipment shall be used.

2.9.1.3 For the purpose of this section, waters that are not exposed are those where the environmental impact on the lifting operation is negligible. Otherwise, waters are to be considered exposed. In general, waters that are not exposed are calm stretches of water, i.e. estuaries, roadsteads, bays, lagoons; where the wind fetch\* is six nautical miles or less.

\* Wind fetch is an unobstructed horizontal distance over which the wind can travel over water in a straight direction.

## **2.9.2 Load and vertical centre of gravity for different types of lifting operations**

2.9.2.1 In lifting operations involving a lifting appliance consisting of a crane, derrick, sheerlegs, a-frame or similar:

- .1 the magnitude of the vertical load ( $P_L$ ) should be the maximum allowed static load at a given outreach of the lifting appliance;
- .2 the transverse distance ( $y$ ) is the transverse distance between the point at which the vertical load is applied to the lifting appliance and the ship centreline in the upright position;
- .3 the vertical height of the load ( $KG_{load}$ ) is taken as the vertical distance from the point at which the vertical load is applied to the lifting appliance to the baseline in the upright position; and
- .4 the change of centre of gravity of the lifting appliance(s) need to be taken into account.

2.9.2.2 In lifting operations not involving a lifting appliance consisting of a crane, derrick, sheerlegs, a-frame or similar, which involve lifting of fully or partially submerged objects over rollers or strong points at or near a deck-level:

- .1 the magnitude of the vertical load ( $P_L$ ) should be the winch brake holding load;
- .2 the transverse distance ( $y$ ) is the transverse distance between the point at which the vertical load is applied to the ship and the ship centreline in the upright position; and
- .3 the vertical height of the load ( $KG_{load}$ ) is taken as the vertical distance from the point at which the vertical load is applied to the ship to the baseline in the upright position.

## **2.9.3 Stability criteria**

2.9.3.1 The stability criteria included herein, or the criteria contained in paragraphs 2.9.4, 2.9.5 or 2.9.7, as applicable shall be satisfied for all loading conditions intended for lifting with the lifting appliance and its load at the most unfavourable positions. For the purpose of this section, the lifting appliance and its load(s) and their centre of gravity (COG) should be included in the displacement and centre of gravity of the ship, in which case no external heeling moment/heeling lever is applied.

2.9.3.2 All loading conditions utilized during the lifting operations are to comply with the stability criteria given in sections 2.2 and 2.3 of part A. Where the ship's characteristics render compliance with section 2.2 of part A impracticable, the equivalent stability criteria given in chapter 4 of the explanatory notes to the 2008 IS Code should apply. During the lifting operation, as determined by paragraphs 2.9.1, the following stability criteria should also apply:

- .1 the equilibrium heel angle,  $\phi_1$ , shall not be greater than the maximum static heeling angle for which the lifting device is designed and which has been considered in the approval of the loading gear;

- .2 during lifting operations in non-exposed waters, the minimum distance between the water level and the highest continuous deck enclosing the watertight hull, taking into account trim and heel at any position along the length of the ship, shall not be less than 0.50 m; and
- .3 during lifting operations in exposed waters, the residual freeboard shall not be less than 1.00 m or 75% of the highest significant wave height  $H_s$ , in (m), encountered during the operation, whichever is greater.

#### **2.9.4 Lifting operations conducted under environmental and operational limitations**

2.9.4.1 For lifting conditions carried out within clearly defined limitations set forth in paragraph 2.9.4.1.1, the intact criteria set forth in paragraph 2.9.4.1.2 may be applied instead of the criteria included in paragraph 2.9.3.

- .1 The limits of the environmental conditions should specify at least the following:
  - the maximum significant wave height,  $H_s$ ; and
  - the maximum wind speed (1 minute sustained at 10 m above sea level).

The limits of the operational conditions should specify at least the following:

- the maximum duration of the lift;
  - limitations in ship speed; and
  - limitations in traffic/traffic control.
- .2 The following stability criteria should apply with the lifted load is at the most unfavourable position:
    - .1 the corner of the highest continuous deck enclosing the watertight hull shall not be submerged;
    - .2  $A_{RL} \geq 1.4 \times A_{HL}$

where:

$A_{RL}$  = The area under the net righting lever curve, corrected for crane heeling moment and for the righting moment provided by the counter ballast if applicable, extending from the equilibrium heeling angle,  $\varphi_I$ , to the angle of down flooding,  $\varphi_F$ , the angle of vanishing stability,  $\varphi_R$ , or the second intersection of the righting lever curve with the wind heeling lever curve, whichever is less, see figure 2.9-1;

$A_{HL}$  = The area below the wind heeling lever curve due to the wind force applied to the ship and the lift at the maximum wind speed specified in paragraph 2.9.4.1.1, see figure 2.9-1.

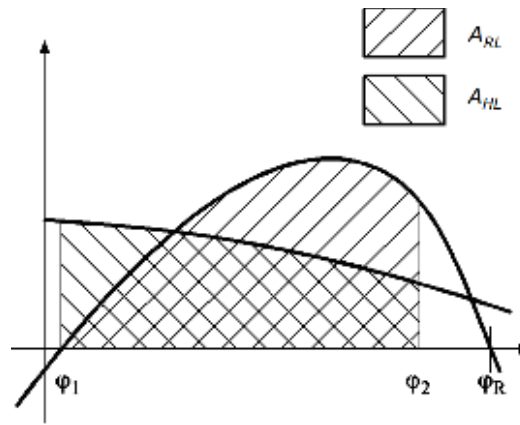

**Figure 2.9-1 – Intact criteria under Environmental and Operational limitations**

- .3 The area under the net righting lever curve from the equilibrium heel angle,  $\phi_1$ , to the downflooding angle  $\phi_F$ , or  $20^\circ$ , whichever is less, shall be at least 0.03 m rad.

### 2.9.5 Sudden loss of hook load

2.9.5.1 A ship engaged in a lifting operation and using counter ballasting should be able to withstand the sudden loss of the hook load, considering the most unfavourable point at which the hook load may be applied to the ship (i.e. largest heeling moment). For this purpose, the area on the side of the ship opposite to the lift (Area 2) should be greater than the residual area on the side of the lift (Area 1), as shown in figure 2.9-2, by an amount given by the following:

Area 2 > 1.4 × Area 1, for lifting operations in waters that are exposed.

Area 2 > 1.0 × Area 1, for lifting operations in waters that are not exposed.

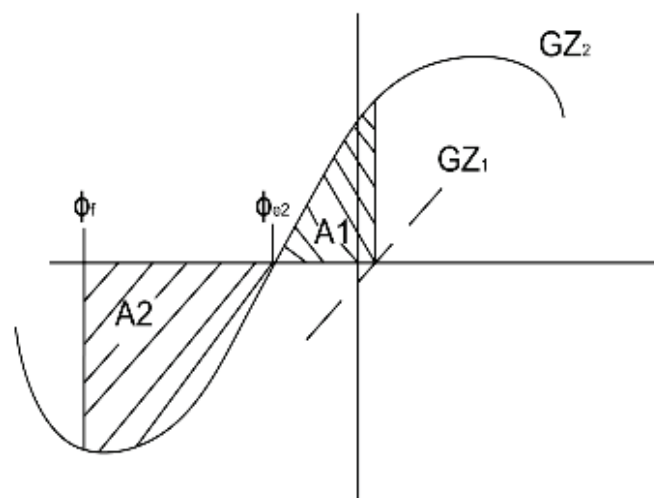

**Figure 2.9-2**



where:

- $GZ_1$  = net righting lever ( $GZ$ ) curve for the condition before loss of crane load, corrected for crane heeling moment and for the righting moment provided by the counter ballast if applicable;
- $GZ_2$  = net righting lever ( $GZ$ ) curve for the condition after loss of crane load, corrected for the transverse moment provided by the counter ballast if applicable;
- $\varphi_{e2}$  = the angle of static equilibrium after loss of crane load;
- $\varphi_f$  = the angle of down-flooding or the heel angle corresponding to the second intersection between heeling and righting arm curves, whichever is less; and

The term "net righting lever" means that the calculation of the  $GZ$  curve includes the ship's true transverse centre of gravity as function of the angle of heel.

## 2.9.6 Alternative method

2.9.6.1 The criteria in paragraph 2.9.6 may be applied to a ship engaged in a lifting operation, as determined by paragraph 2.9.1, as an alternative to the criteria in paragraph 2.9.3 through paragraph 2.9.5, as applicable. For the purpose of this section and the stability criteria set out in paragraph 2.9.7, the lifted load which causes the ship to heel is translated for the purpose of stability calculation to a heeling moment/heeling lever which is applied on the righting lever curve of the ship.

2.9.6.2 The heeling moment applied to the ship due to a lift and the associated heeling lever should be calculated using the following formulae:

$$HM_{\varphi} = P_L \cdot y \cdot \cos \varphi$$

$$HL_{\varphi} = HM_{\varphi} \div \Delta$$

where:

- $HM_{\varphi}$  = the heeling moment, in (t-m), due to the lift at  $\varphi$ ;
- $P_L$  = the vertical load, in (t), of the lift, as defined in 2.9.2.1.1;
- $y$  = the transverse distance, in (m), of the lift, metres, as defined in 2.9.2.1.2;
- $\varphi$  = the angle of heel;
- $HL_{\varphi}$  = the heeling lever, in (m) due to the lift at  $\varphi$ ; and
- $\Delta$  = the displacement, in (t) of the ship with the load of the lift.

2.9.6.3 For application of the criteria contained in paragraph 2.9.7 involving the sudden loss of load of the lift in which counter-ballast is used, the heeling levers that include the counter-ballast should be calculated using the following formulae:

$$CHL_1 = \frac{(P_L \cdot y - CBM) \cdot \cos \varphi}{\Delta}$$

$$CBHL_2 = \frac{CBM \cdot \cos \varphi}{(\Delta - P_L)}$$

where:

- $CBM$  = the heeling moment, in (t.m), due to the counter-ballast;
- $CHL_1$  = combined heeling lever, in (m), due to the load of the lift and the counter-ballast heeling moment at the displacement corresponding to the ship with the load of the lift; and
- $CBHL_2$  = heeling lever, in (m), due to the counter-ballast heeling moment at the displacement corresponding to the ship without the load of the lift.

2.9.6.4 The equilibrium heel angle  $\varphi_e$  referred to in 2.9.7 means the angle of first intersection between the righting lever curve and the heeling lever curve.

### **2.9.7 Alternative stability criteria**

2.9.7.1 For the loading conditions intended for lifting, but before commencing the operation, the stability criteria given in sections 2.2 and 2.3 of part A should be complied with. Where a ship's characteristics render compliance with section 2.2 of part A impracticable, the equivalent stability criteria given in chapter 4 of the explanatory notes to the 2008 IS Code should apply. During the lifting operation, as determined by paragraph 2.9.1, the following stability criteria should apply:

- .1 the residual righting area below the righting lever and above the heeling lever curve between  $\varphi_e$  and the lesser of 40° or the angle of the maximum residual righting lever should not be less than:  
  
0.080 m rad, if lifting operations are performed in waters that are exposed; or  
  
0.053 m rad, if lifting operations are performed in waters that are not exposed;
- .2 in addition, the equilibrium angle is to be limited to the lesser of the following:
  - .1 10 degrees;
  - .2 the angle of immersion of the highest continuous deck enclosing the watertight hull; or
  - .3 the lifting appliance allowable value of trim/heel (data to be derived from sidelead and offlead allowable values obtained from manufacturer).

2.9.7.2 A ship engaged in a lifting operation and using counter ballasting should be able to withstand the sudden loss of the hook load, considering the most unfavourable point at which the hook load may be applied to the ship (i.e. largest heeling moment). For this purpose, the area on the side of the ship opposite from the lift (Area 2) in figure 2.9-3 should be greater than the residual area on the side of the lift (Area 1) in figure 2.9-3 by an amount given by the following:

$$\text{Area 2} - \text{Area 1} > K,$$

where:

- $K = 0.037$  m rad, for a lifting operation in waters that are exposed; and  
 $K = 0.0$  m rad, for a lifting operation in waters that are not exposed.

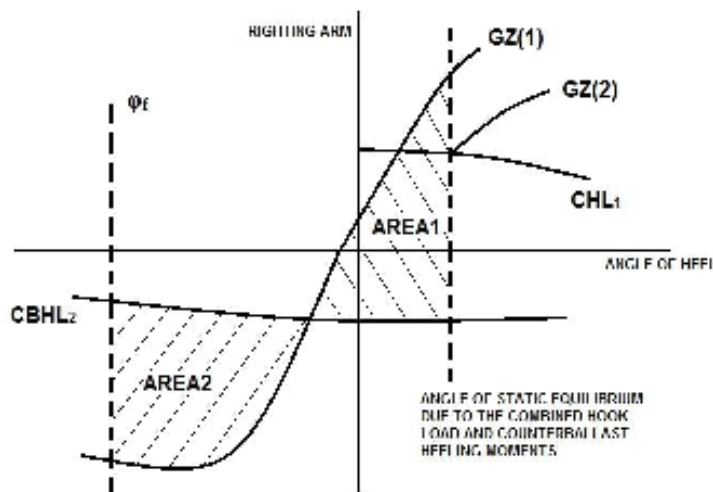

**Figure 2.9-3**

- $GZ(1)$  = The righting arm curve at the displacement corresponding to the ship without hook load;  
 $GZ(2)$  = The righting arm curve at the displacement corresponding to the ship with hook load;  
 Area2 = residual area between  $GZ(1)$  and  $CHL_2$  up to the lesser of the down-flooding angle or the second intersection of  $GZ(2)$  and  $CHL_2$ ;  
 Area1 = residual area below  $GZ(1)$  and above  $CHL_2$  up to  $\phi_e$ .

### 2.9.8 Model tests or direct calculations

2.9.8.1 Model tests or direct calculations, performed in accordance with a methodology acceptable to the Administration, that demonstrate the survivability of the ship after sudden loss of hook load, may be allowed as an alternative to complying with the requirements of paragraph 2.9.5 or 2.9.7.2, provided that:

- .1 the effects of wind and waves are taken into account; and
- .2 the maximum dynamic roll amplitude of the ship after loss of load will not cause immersion of unprotected openings.

### 2.9.9 Operational procedures against capsizing

2.9.9.1 Ships should avoid resonant roll conditions when engaged in lifting operations."

### Chapter 3 – Guidance in preparing stability information

#### 3.4 Standard conditions of loading to be examined

##### 3.4.1 Loading conditions

6 The following new paragraphs 3.4.1.7 to 3.4.1.10 are added after existing paragraph 3.4.1.6:

"3.4.1.7 For a ship engaged in an anchor handling operation, the standard loading conditions should be as follows, in addition to the standard loading conditions for a cargo ship in paragraph 3.4.1.2:

- .1 service loading condition at the maximum draught at which anchor handling operations may occur with the heeling levers as defined in paragraph 2.7.2 for the line tension the ship is capable of with a minimum of 67% stores and fuel, in which all the relevant stability criteria as defined in paragraph 2.7.4 are met;
- .2 service loading condition at the minimum draught at which anchor handling operations may occur with the heeling levers as defined in paragraph 2.7.2 for the line tension the ship is capable of with 10% stores and fuel, in which all the relevant stability criteria as defined in paragraph 2.7.4 are met.

3.4.1.8 For a ship engaged in a harbour, coastal or ocean going towing operation and/or escort operation, the following loading conditions should be included in addition to the standard loading conditions for a cargo ship in paragraph 3.4.1.2:

- .1 maximum operational draught at which towing or escorting operations are carried out, considering full stores and fuel;
- .2 minimum operational draught at which towing or escorting operations are carried out, considering 10% stores and fuel; and
- .3 intermediate condition with 50% stores and fuel.

3.4.1.9 For ships engaged in lifting, loading conditions reflecting the operational limitations of the ship, while engaged in lifting shall be included in the stability booklet. Use of counter ballast, if applicable, shall be clearly documented, and the adequacy of the ships stability in the event of the sudden loss of the hook load shall be demonstrated.

3.4.1.10 The criteria stated in paragraphs 2.9.3, 2.9.4, 2.9.5 or 2.9.7, as applicable, shall be satisfied for all loading conditions intended for lifting and with the hook load at the most unfavourable positions. For each loading condition, the weight and centre of gravity of the load being lifted, the lifting appliance, and counter ballast, if any, should be included. The most unfavourable position may be obtained from the load chart and is chosen at the position where the total of the transverse and vertical moment is the greatest. Additional loading conditions corresponding to various boom positions and counter ballast with different filling level (if applicable) may need to be checked."

### **3.4.2 Assumptions for calculating loading conditions**

7 In paragraph 3.4.2.3, the following sentence is inserted at the end:

"If a ship operates in zones where ice accretion is likely to occur, allowance for icing should be made in accordance with the provisions of chapter 6 (Icing considerations)."

8 Subparagraph 3.4.2.7.5 is deleted.

9 Subparagraph 3.4.2.8.2 is deleted and the remaining subparagraphs are renumbered accordingly.

10 The following new paragraphs 3.4.2.9 to 3.4.2.11 are added as follows:

"3.4.2.9 For ships engaged in harbour, coastal or ocean going towing, escort towing, anchor handling or lifting operations, allowance should be made for the anticipated weight of cargo on and below deck, chain in lockers, anticipated type of wire or rope on storage reels and wire on the winches when calculating loading conditions.

3.4.2.10 For ships engaged in anchor handling operations, the compliance with the relevant stability criteria should be made for each set of towing pins and its associated permissible line tensions, including any physical element or arrangement that can restrict the line movement.

3.4.2.11 For ships engaged in anchor handling operations, the reference loading conditions in paragraph 3.4.1.8 should meet the stability criteria in paragraph 2.7.4 when applying the design tension  $F_d$ , for the tow pin set nearest to centreline, as a minimum for the lowest  $\alpha$  equal to 5 degrees."

### **3.5 Calculation of stability curves**

11 The following new section 3.5.4 is added after existing section 3.5.3:

#### **"3.5.4 Calculation of stability curves for ships engaged in anchor handling operations to which section 2.7 applies**

3.5.4.1 Curves (or tables) of the permissible tension as a function of permissible KG (or GM) are to be provided for the draught (or displacement) and trim values covering the intended anchor handling operations. The curves (or tables) should be developed under the following assumptions:

- .1 the maximum allowable KG from the approved stability booklet;
- .2 information of permissible tension curve or table for each set of towing pins, including any physical element or arrangement that can restrict the line movement as function of the stability limiting curve should be included;
- .3 where desirable, a permissible tension curve or table should be provided for any specific loading condition;
- .4 the draught (or displacement), trim and KG (or GM) to be taken into consideration are those before application of the tension; and

- .5 where tables are provided that divide the operational, cautionary, and stop work zones, referred to in paragraph 3.8.2 ("Green", "Yellow" or "Amber", "Red" colour codes, respectively) the limiting angles associated with physical features of the stern, including the roller, may be used to define the boundaries between the operational and cautionary zones (green/yellow boundary) and the cautionary and stop work zones (yellow/red boundary)."

### **3.6 Stability booklet**

12 The following new paragraphs 3.6.3 to 3.6.5 are inserted after existing paragraph 3.6.2:

"3.6.3 The stability manual for ships engaged in anchor handling operations should contain additional information on:

- .1 maximum bollard pull, winch pull capacity and brake holding force;
- .2 details on the anchor handling arrangement such as location of the fastening point of the wire, type and arrangement of towing pins, stern roller, all points or elements where the tension is applied to the ship;
- .3 identification of critical downflooding openings;
- .4 guidance on the permissible tensions for each mode of operation and for each set of towing pins, including any physical element or arrangement that can restrict the wire movement, as function of all relevant stability criteria; and
- .5 recommendations on the use of roll reduction systems.

3.6.4 The stability booklet for ships engaged in harbour, coastal or ocean going towing operations and/or escort operations should contain additional information on:

- .1 maximum bollard pull;
- .2 details on the towing arrangement, including location and type of the towing point(s), such as towing hook, staple, fairlead or any other point serving that purpose;
- .3 identification of critical down-flooding openings;
- .4 recommendations on the use of roll reduction systems;
- .5 if any wire, etc. is included as part of the lightship weight, clear guidance on the quantity and size should be given;
- .6 maximum and minimum draught for towing and escort operations;
- .7 instructions on the use of the quick-release device; and

- .8 for ships engaged in escort operations, the following additional operating information should be included:
  - .1 a table with permissible limits of the heel angle in accordance with the criteria included in paragraph 2.7.3.4 as function of loading condition and escort speed; and
  - .2 instructions on the available means to limit the heel angle within the permissible limits.

3.6.5 For ships engaged in lifting operations, for which section 2.9 applies, additional documentation should be included in the stability booklet:

- .1 maximum heeling moment for each direction of lift/inclination as a function of the counter-ballast heeling moment, if used, the draught, and vertical centre of gravity;
- .2 where fixed counter ballast is used, the following information should be included:
  - .1 weight of the fixed counter ballast; and
  - .2 centre of gravity (LCG, TCG, VCG) of the fixed counter ballast;
- .3 loading conditions over the range of draughts for which lifting operations may be conducted with the maximum vertical load of the lift. Where applicable, righting lever curves for both before and after load drop should be presented for each loading condition;
- .4 limitations on crane operation, including permissible heeling angles, if provided;
- .5 operational limitations, such as:
  - .1 Maximum Safe Working Load (SWL);
  - .2 maximum radius of operation of all derricks and lifting appliances;
  - .3 maximum load moment; and
  - .4 environmental condition affecting the stability of the ship;
- .6 instructions related to normal crane operation, including those for use of counter ballast;
- .7 instructions such as ballasting/de-ballasting procedures to righting the ship following an accidental load drop;
- .8 identification of critical down-flooding openings;
- .9 recommendations on the use of roll reduction systems;

- .10 drawing of the crane showing the weight and centre of gravity, including heel/trim limitations established by the crane manufacturer;
- .11 a crane load chart, with appropriate de-ratings for wave height;
- .12 load chart for lifting operations covering the range of operational draughts related to lifting and including a summary of the stability results;
- .13 a crane specification manual provided by the manufacturer shall be submitted separately for information;
- .14 the lifting appliance load, radius, boom angle limit table, including identification of offlead and sidelead angle limits and slewing angle range limits and reference to the ship's centreline;
- .15 a table that relates the ship trim and heel to the load, radius, slewing angle and limits, and the offlead and sidelead limits;
- .16 procedures for calculating the offlead and sidelead angles and the ship VCG with the load applied;
- .17 if installed, data associated with a Load Moment Indicator system and metrics included in the system;
- .18 if lifting appliance (crane) offlead and sidelead determine the maximum ship equilibrium angle, the stability booklet should include a note identifying the lifting appliance as the stability limiting factor during lifting operations; and
- .19 information regarding the deployment of (stability) pontoons to assist a lifting operation, if fitted.

The information in subparagraphs .2 to .19 above may be included in other ship specific documentation on board the ship. In that case, a reference to these documents shall be included in the stability booklet."

and the existing paragraphs 3.6.3, 3.6.4 and 3.6.5 are renumbered as paragraphs 3.6.6, 3.6.7 and 3.6.8 accordingly.

### **3.8 Operating booklets for certain ships**

13 The following new sections 3.8 and 3.9 are inserted after existing section 3.7:

#### **"3.8 Operational and planning manuals for ships engaged in anchor handling for which section 2.7 applies:**

3.8.1 To assist the master an operational and planning manual containing guidelines for planning and performing specific operations should be provided on board. The guidelines should contain sufficient information to enable the master to plan and operate the ship in compliance with the applicable requirements contained in this Code. The following information should be included as appropriate:



- .1 anchor handling arrangements, including:
  - detail arrangement of anchor handling deck equipment (winches, wire stoppers, towing pins, etc.);
  - typical arrangement of cargo on deck (anchors, wires, chain cables, etc.);
  - chain lockers used for mooring deployment;
  - anchor handling/towing winch;
  - tugger winches;
  - stern roller, including lateral limits on both ends;
  - lifting appliances, if any and if forming a physical restriction as per paragraph 3.4.2.10; and
  - typical paths of wires between winches and stern roller, showing the limit sectors; and
- .2 detailed data of the permissible tensions, stability limiting curves, and recommendations for calculating ship's loading conditions including sample calculations.

3.8.2 An operation plan should be agreed to by the master of the ship and a copy archived on a remote location before the operation commences. Guidelines and procedures to define a step-wise operational plan for a specific operation should contain instructions for:

- .1 identifying and calculating loading conditions for all relevant stages of operation, taken into account the expected fuel and stores consumption, alterations on deck load, effects of deployment or recovering of the wire on the winches and chain lockers;
- .2 planning ballast operations;
- .3 defining the most favourable consumption sequence and identifying the most onerous situations;
- .4 identifying the possibility or prohibition of using the roll reduction systems in all operational stages;
- .5 operation with open chain lockers, e.g. additional loading conditions for asymmetric filling or other measures to reduce the possibility of flooding;
- .6 collect updated weather forecasts, and to define environmental conditions for anchor handling operations;
- .7 the use of limiting stability curves and intended tensions;

- .8 defining the stop work limits:
  - .a permissible tensions and operational sectors for  $\alpha$ ;
  - .b heeling angles in compliance with the stability criteria; and
  - .c environmental conditions;
- .9 implement and define corrective and emergency procedures;
- .10 define:
  - .a an operational zone in which normal operations up to the permissible tension are to occur (i.e. a "Green" zone);
  - .b a cautionary zone (i.e. a "Yellow" or "Amber" zone) where operations may be reduced or halted to assess the ship's options to return to the operational or Green Zone: the cautionary zone should be not less than an angle of 10 degrees unless table 3.8.3 provides otherwise; and
  - .c a "Stop work" zone (i.e. a "Red" zone) in which the operation should be stopped, for which, in normal operations, the yellow/red boundary should not exceed 45 degrees or the point at which the wire rises above the deck. Notwithstanding this, due consideration may be given to different operations from typical anchor handling operations where the planned operation ensures the safety of the ship; and
- .11 examples of presentation of permissible tensions are presented in annex 3 to part B.

3.8.3 To aid the definition of permissible tensions and zones based on the availability of tension monitoring and an onboard stability instrument the following table is provided.

**Table 3.8.3**

Availability of Tension Monitoring and an onboard Stability Instrument	Tension monitoring is not available	Tension monitoring is available but no stability instrument is available	Both tension monitoring and a stability instrument is available
Permissible tension, $F_p$	Design Maximum Line Tension, $F_p$ , in the operational zone.	$F_p$ as described in Stability Booklet, the operational planning guidelines, or the specific operational plan.	$F_p$ as calculated by the Stability Instrument for the actual loading condition.
Permissible table	First $\alpha$ should be 5°. The only permissible tension is the Design maximum wire	Tables may be prepared for different values of draft, trim, KG or	Tables or curves provided in the stability booklet may be used where $F_p$

Availability of Tension Monitoring and an onboard Stability Instrument	Tension monitoring is not available	Tension monitoring is available but no stability instrument is available	Both tension monitoring and a stability instrument is available
	<p>Tension, <math>F_d</math>. Figures in the table will be <math>F_d</math> for <math>\alpha</math> for which <math>F_p \geq F_d</math>. The cautionary zone would include positions where <math>F_d &gt; F_p \geq</math> maximum winch wire pull. The stop work zone is every other position where <math>F_p &lt;</math> the maximum winch wire pull. If criteria is not fulfilled at <math>\alpha = 5^\circ</math> anchor handling should not be performed without winch modification.</p>	<p>GM, or specific predefined loading conditions. Values in the table should range from <math>\alpha = 0</math> to <math>\alpha = 90^\circ</math>. A table should identify <math>F_p</math> at critical points and the table should be provided for each set of towing pins.</p>	<p>throughout the nonspecific operational zone exceeds the maximum anticipated wire tension; otherwise, tables or curves calculated for the actual loading condition must be developed.</p>

Availability of Tension Monitoring and an onboard Stability Instrument	Tension monitoring is not available	Tension monitoring is available but no stability instrument is available	Both tension monitoring and a stability instrument is available
Zones	<p>The operational zone should be defined as the sector between the two outboard <math>\alpha</math> values for which <math>F_p \geq F_d</math>. The cautionary zone should be defined as the sector between the <math>\alpha</math> at which <math>F_p = F_d</math> and <math>\alpha</math> at which <math>F_p = \text{maximum winch wire pull}</math>.</p> <p>The stop work zone should cover every other position. The sectors should be documented in the Stability Booklet, the operational planning guidelines, or the specific operational plan. The sector diagram may be prepared for multiple loading conditions. If the limiting <math>\alpha</math> is less than <math>5^\circ</math> anchor handling operations should not be performed without winch modifications.</p>	<p>The zones may be developed based on normal operational practices contained in the operational planning guidelines, e.g. the operational zone on the stern roller, cautionary zone for not more than <math>15\text{deg}</math> past the stern roller and the red zone otherwise or developed for a specific operation where the outboard <math>\alpha</math> values at which <math>F_p = \text{maximum anticipated wire tension minus } 10^\circ</math> defines the operational zone, if <math>\alpha</math> is greater than <math>20^\circ</math>. If this <math>\alpha</math> is less than <math>20^\circ</math>, the operational zone is defined as the sector between <math>\frac{1}{2}</math> the outboard <math>\alpha</math> values at which <math>F_p = \text{maximum anticipated wire tension}</math>. In each case, the cautionary zone is defined between the limit of the operational zone and the <math>\alpha</math> value at which <math>F_p = \text{maximum anticipated wire tension}</math>. In each case, the operational zone must be identified for the anticipated wire tension.</p>	<p>The zones may be developed based on normal operational practices contained in the operational planning guidelines, e.g. the operational zone on the stern roller, cautionary zone for not more than <math>15\text{deg}</math> past the stern roller and the red zone otherwise or developed for a specific operation where the outboard <math>\alpha</math> values at which <math>F_p = \text{maximum anticipated wire tension minus } 10^\circ</math> defines the operational zone, if <math>\alpha</math> is greater than <math>20^\circ</math>. If this <math>\alpha</math> is less than <math>20^\circ</math>, the operational zone is defined as the sector between <math>\frac{1}{2}</math> the outboard <math>\alpha</math> values at which <math>F_p = \text{maximum anticipated wire tension}</math>. In each case, the cautionary zone is defined between the limit of the operational zone and the <math>\alpha</math> value at which <math>F_p = \text{maximum anticipated wire tension}</math>. In each case, the operational zone must be identified for the anticipated wire tension.</p>

**3.9 Operational and planning booklets for ships engaged in lifting for which section 2.9 applies**

3.9.1 An operation plan should be agreed to by the Master of the ship and a copy archived on a remote location before the operation commences. To assist the master an operational and planning booklet containing guidelines for planning and performing specific operations should be provided on board.

3.9.2 The guidelines should contain sufficient information to enable the Master to plan and operate the ship in compliance with the applicable requirements contained in this Code. The following information should be included as appropriate:

- .1 lifting arrangements, capabilities and procedures to operate the lifting systems; and
- .2 detailed data concerning the ship's lifting capability, operational limitations, limitations of cargo capacities, stability limiting curves and recommendations for calculating ship's loading conditions including sample calculations.

3.9.3 Guidelines and procedures to define a step-wise operational plan for a specific operation should contain instructions for:

- .1 identifying and calculating loading conditions for all relevant stages of operation, taking into account the alterations on deck load, effects of deployment or recovering of the line on the winches (in particular for deep water lifting);
- .2 planning ballast or counter ballast operations;
- .3 identifying the possibility to use the roll reduction systems in all operational stages;
- .4 collecting latest weather forecasts in order to define the environmental conditions for the intended lifting operation;
- .5 using limiting stability curves, if applicable;
- .6 defining the stop work limits:
  - .1 heeling angles in compliance with the stability criteria; and
  - .2 environmental conditions; and
- .7 defining and implementing corrective and emergency procedures."

and the existing section 3.8 is renumbered as section 3.10.

## **Chapter 4 – Stability calculations performed by stability instruments**

### **4.1      *Stability instruments***

#### 4.1.4    Functional requirements

14        The following new paragraph 4.1.4.2 is inserted after existing paragraph 4.1.4.1:

"4.1.4.2 For ships engaged in anchor handling operations planning tools should be provided in compliance with operational manual requirements. Information such as ballasting and consumables sequences, permissible tension, working sectors, heeling angles and use of roll-reduction devices should be stated."

and the existing paragraphs 4.1.4.2 to 4.1.4.7 are renumbered as 4.1.4.3 to 4.1.4.8 accordingly.

Part B – Annexes

15 A new annex 3 is added at the end of part B as follows:

"Annex 3

Recommended model for graphic or tabular presentation of permissible tensions for use in anchor handling operations.

The insertion of a recommended model for the presentation of permissible tensions as function of  $\alpha$  might be beneficial for a universal information standard. This uniform presentation will facilitate the circulation and the familiarization of the operators with the ship and its equipment.

A possible graphic presentation of the permissible tension is here included as an example, both table and diagram format.

PERMISSIBLE WIRE TENSION TABLE FOR A SAMPLE AHTS																								
Trim (M)	-0.5	0.0	0.5	-0.5	0.0	0.5	-0.5	0.0	0.5	-0.5	0.0	0.5	-0.5	0.0	0.5	-0.5	0.0	0.5	-0.5	0.0	0.5	-0.5	0.0	0.5
Angle $\alpha$	0			10			20			30			45			60			90					
Draft (M)																								
<b>Between the Centerline Towing Pins</b>																								
4.8	700	700	700	700	700	690	625	380	340	460	460	435	290	290	290	190	190	190	165	165	165			
5.8	700	700	700	700	700	690	635	600	550	430	485	435	285	285	310	190	180	200	170	165	170			
6.8	700	635	520	700	635	520	645	575	510	550	485	415	355	355	305	230	240	220	200	205	200			
<b>Between the Outer Towing Pins</b>																								
4.8	345	500	465	480	435	405	385	380	350	300	300	300	215	215	215	170	170	170	165	165	165			
5.8	375	520	465	500	455	405	360	390	350	275	300	300	220	210	240	180	175	190	170	165	170			
6.8	555	480	410	500	435	370	440	385	330	365	340	295	260	270	235	210	215	200	200	205	200			
<b>Towing Pin at the Edge of the Cargo Rail</b>																								
4.8	280	280	270	260	260	260	235	235	235	215	215	215	180	180	180	170	170	170	160	160	160			
5.8	255	290	280	240	260	265	230	235	250	210	200	235	190	180	200	175	170	180	165	160	165			
6.8	345	310	270	320	300	260	290	285	245	260	270	230	220	230	210	205	210	200	195	200	195			
Max Wire Pull: 600 t    Max Brake Force: 700 t    Max Dynamic Brake: 700 t    Resulting Fd = 700 t																								
Trim is Negative by the bow. Interpolate between drafts only. For trim between table values, use lower permissible tension.												Permissible tensions shown are in Tonnes. Required tension should not exceed the winches capabilities or the values in the above table.												
Table is for Planning and Monitoring AHTS operation. Specific loading conditions may be required for each anchor move.												If wire angle falls into the yellow zone, and wire tension exceeds the permissible value, corrective actions are required												
Trim should be minimized or by bow for anchor moves where high wire tensions are expected.												If wire angle falls into the red zone, and the wire tension exceeds the permissible value, halt operations, reduce line tension												
Wire angle (alpha $\alpha$ ) is relative to vessel's centerline, and is assumed to always be outboard. If angle is exceeded, use next higher angle.												If planned wire tension exceeds green values above, additional Calculations required. Operations should not be planned for high angles.												
Grey region indicates where the angle of tow wire is not geometrically possible. Permissible tensions are provided for reference only.												Vessel loading must be in accordance with the approved stability book and include any assumed margins												

Figure A3-1: Permissible tension table for ship with 3 tow points

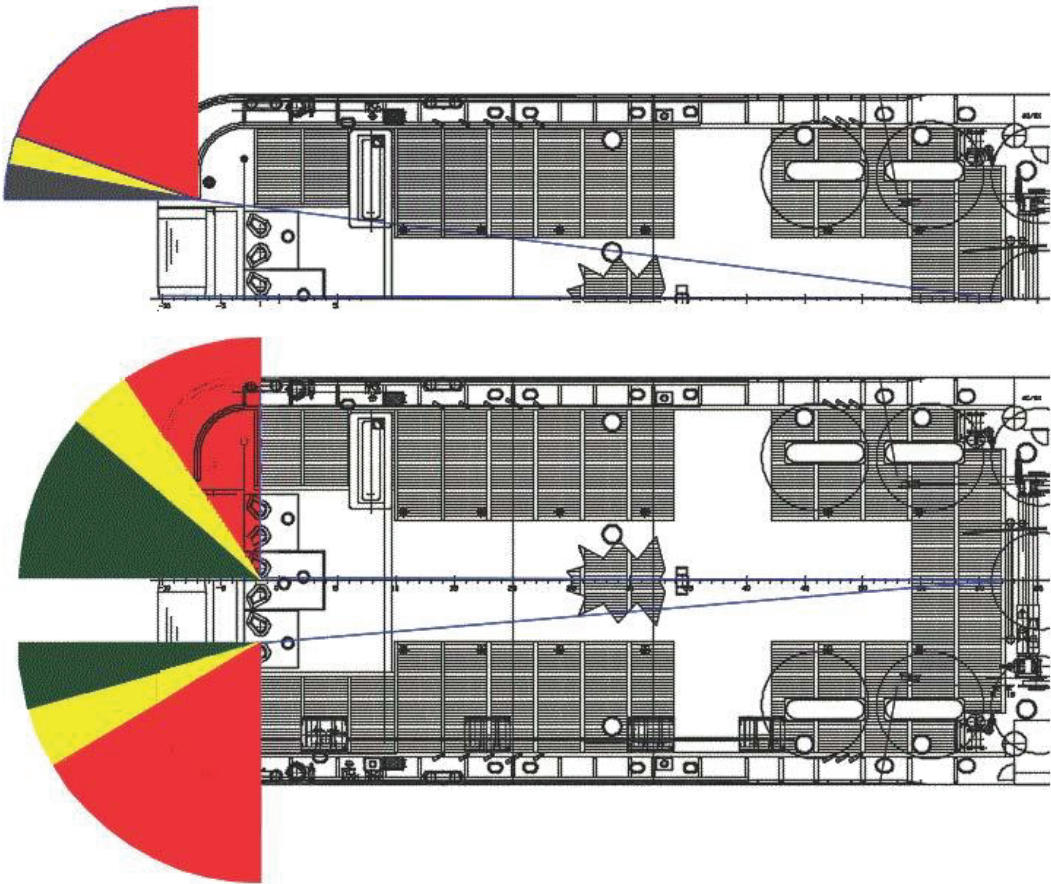

**Figure A3-2: Illustration of the operational, cautionary, and stop work zones (coded respectively "Green", "Yellow" and "Red" zones)**



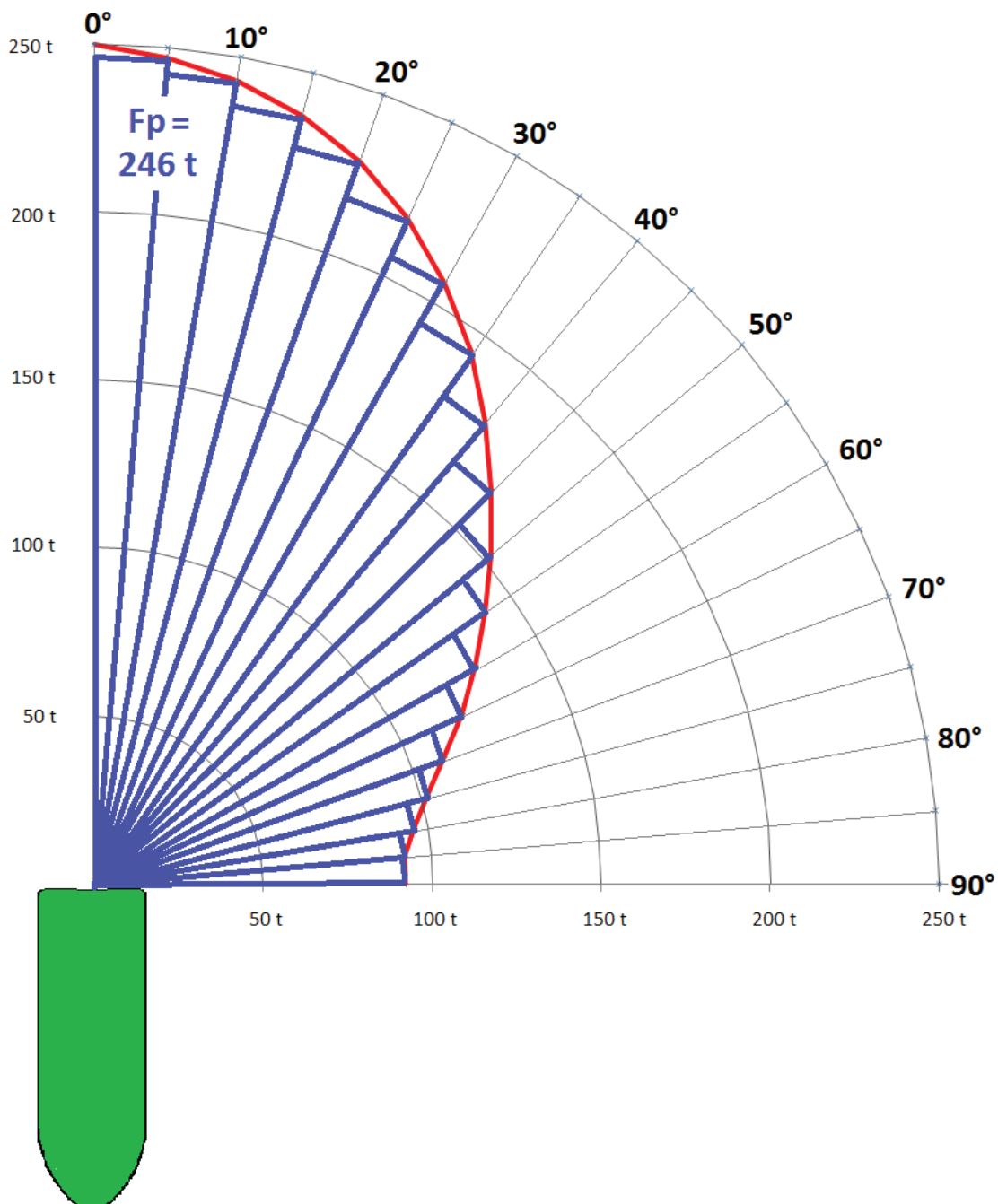

Figure A3-3: Permissible tension sector diagram based on standard alpha values (5°, 10°, 15°, 90°) "

\*\*\*

**ANNEX 8**

**RESOLUTION MSC.416(97)  
(adopted on 25 November 2016)**

**AMENDMENTS TO THE INTERNATIONAL CONVENTION ON  
STANDARDS OF TRAINING, CERTIFICATION AND WATCHKEEPING  
FOR SEAFARERS (STCW), 1978, AS AMENDED**

THE MARITIME SAFETY COMMITTEE,

RECALLING Article 28(b) of the Convention on the International Maritime Organization concerning the functions of the Committee,

RECALLING ALSO Article XII of the International Convention on Standards of Training, Certification and Watchkeeping for Seafarers, 1978 ("the Convention"), concerning the procedures for amending the Convention,

RECALLING FURTHER that the Committee, by resolution MSC.386(94), adopted, inter alia, the new chapter XIV of the International Convention for the Safety of Life at Sea (SOLAS), 1974, as amended,

ALSO RECALLING that the Committee, by resolution MSC.385(94), adopted the *International Code for Ships Operating in Polar Waters (Polar Code)*, which will take effect on 1 January 2017 upon entry into force of the new chapter XIV of the SOLAS Convention,

NOTING that there will be a transitional period between the entry into force of the Polar Code and the amendments to the STCW Convention, and that section B-V/g of the STCW Code provides guidance regarding the training of masters and officers for ships operating in polar waters which should be applied by Administrations during the transitional period,

ALSO RECALLING that the Committee, at its ninety-sixth session, decided to provide the Member States with a single resolution of amendments to the Convention, including those related to the Polar Code and to passenger ship-specific training and certification,

HAVING CONSIDERED, at its ninety-seventh session, amendments to the Convention proposed and circulated in accordance with Article XII(1)(a)(i) thereof,

1 ADOPTS, in accordance with Article XII(1)(a)(iv) of the Convention, amendments to the Convention, the text of which is set out in the annex to the present resolution;

2 DETERMINES, in accordance with Article XII(1)(a)(vii)(2) of the Convention, that the said amendments shall be deemed to have been accepted on 1 January 2018, unless, prior to that date, more than one third of Parties or Parties the combined merchant fleets of which constitute not less than 50% of the gross tonnage of the world's merchant shipping of ships of 100 gross register tons or more, have notified the Secretary-General of the Organization of their objections to the amendments;

3 INVITES Parties to note that, in accordance with Article XII(1)(a)(ix) of the Convention, that the amendments annexed hereto shall enter into force on 1 July 2018 upon their acceptance, in accordance with paragraph 2 above;

4 URGES Parties to implement the amendments to regulation I/1.1, regulation I/11 and regulation V/4 at an early stage;

5 INVITES Parties to recognize seafarers' certificates issued by a Party at an early stage, in accordance with paragraph 4 above, and prior to the entry into force of amendments to regulation V/4;

6 REQUESTS the Secretary-General, for the purposes of Article XII(1)(a)(v) of the Convention, to transmit certified copies of the present resolution and the text of the amendments contained in the annex to all Parties to the Convention;

7 REQUESTS ALSO the Secretary-General to transmit copies of this resolution and its annex to Members of the Organization, which are not Parties to the Convention.

## ANNEX

### AMENDMENTS TO THE INTERNATIONAL CONVENTION ON STANDARDS OF TRAINING, CERTIFICATION AND WATCHKEEPING FOR SEAFARERS (STCW), 1978, AS AMENDED

#### CHAPTER I

##### General provisions

- 1 In regulation I/1.1, the following new definitions are added:
- "42 *Polar Code* means the International Code for Ships Operating in Polar Waters, as defined in SOLAS regulation XIV/1.1.
- .43 *Polar waters* means Arctic waters and/or the Antarctic area, as defined in SOLAS regulations XIV/1.2 to XIV/1.4."
- 2 In regulation I/11, after the existing paragraph 3, the following new paragraph is inserted and the subsequent paragraphs are renumbered accordingly:
- "4 Every master or officer shall, for continuing seagoing service on board ships operating in polar waters, meet the requirements of paragraph 1 of this regulation and be required, at intervals not exceeding five years, to establish continued professional competence for ships operating in polar waters in accordance with section A-1/11, paragraph 4 of the STCW Code."

#### CHAPTER V

##### Special training requirements for personnel on certain types of ships

- 3 In chapter V, the existing regulation V/2 is replaced by the following:

##### **"Regulation V/2**

*Mandatory minimum requirements for the training and qualifications of masters, officers, ratings and other personnel on passenger ships*

- 1 This regulation applies to masters, officers, ratings and other personnel serving on board passenger ships engaged on international voyages. Administrations shall determine the applicability of these requirements to personnel serving on passenger ships engaged on domestic voyages.
- 2 Before being assigned shipboard duties, all persons serving on a passenger ship shall meet the requirements of section A-VI/1, paragraph 1 of the STCW Code.
- 3 Masters, officers, ratings and other personnel serving on board passenger ships shall complete the training and familiarization required by paragraphs 5 to 9 below, in accordance with their capacity, duties and responsibilities.
- 4 Masters, officers, ratings and other personnel, who are required to be trained in accordance with paragraphs 7 to 9 below shall, at intervals not exceeding five years, undertake appropriate refresher training or be required to provide evidence of having achieved the required standard of competence within the previous five years.

5 Personnel serving on board passenger ships shall complete passenger ship emergency familiarization appropriate to their capacity, duties and responsibilities as specified in section A-V/2, paragraph 1 of the STCW Code.

6 Personnel providing direct service to passengers in passenger spaces on board passenger ships shall complete the safety training specified in section A-V/2, paragraph 2 of the STCW Code.

7 Masters, officers, ratings qualified in accordance with chapters II, III and VII and other personnel designated on the muster list to assist passengers in emergency situations on board passenger ships, shall complete passenger ship crowd management training as specified in section A-V/2, paragraph 3 of the STCW Code.

8 Masters, chief engineer officers, chief mates, second engineer officers and any person designated on the muster list of having responsibility for the safety of passengers in emergency situations on board passenger ships shall complete approved training in crisis management and human behaviour as specified in section A-V/2, paragraph 4 of the STCW Code.

9 Masters, chief engineer officers, chief mates, second engineer officers and every person assigned immediate responsibility for embarking and disembarking passengers, for loading, discharging or securing cargo, or for closing hull openings on board ro-ro passenger ships, shall complete approved training in passenger safety, cargo safety and hull integrity as specified in section A-V/2, paragraph 5 of the STCW Code.

10 Administrations shall ensure that documentary evidence of the training which has been completed is issued to every person found qualified in accordance with paragraphs 6 to 9 of this regulation. "

4 In chapter V, the following new regulation is added:

**"Regulation V/4**

*Mandatory minimum requirements for the training and qualifications of masters and deck officers on ships operating in polar waters*

1 Masters, chief mates and officers in charge of a navigational watch on ships operating in polar waters shall hold a certificate in basic training for ships operating in polar waters, as required by the Polar Code.

2 Every candidate for a certificate in basic training for ships operating in polar waters shall have completed an approved basic training for ships operating in polar waters and meet the standard of competence specified in section A-V/4, paragraph 1, of the STCW Code.

3 Masters and chief mates on ships operating in polar waters, shall hold a certificate in advanced training for ships operating in polar waters, as required by the Polar Code.

4 Every candidate for a certificate in advanced training for ships operating in polar waters shall:

- .1 meet the requirements for certification in basic training for ships in polar waters;
- .2 have at least two (2) months of approved seagoing service in the deck department, at management level or while performing watchkeeping duties at the operational level, within polar waters or other equivalent approved seagoing service; and
- .3 have completed approved advanced training for ships operating in polar waters and meet the standard of competence specified in section A-V/4, paragraph 2 of the STCW Code.

5 Administrations shall ensure that a Certificate of Proficiency is issued to seafarers who are qualified in accordance with paragraphs 2 or 4, as appropriate.

*Transitional provisions*

6 Until 1 July 2020, seafarers who commenced approved seagoing service in polar waters prior to 1 July 2018 shall be able to establish that they meet the requirements of paragraph 2 by:

- .1 having completed approved seagoing service on board a ship operating in polar waters or equivalent approved seagoing service, performing duties in the deck department at the operational or management level, for a period of at least three months in total during the preceding five years; or
- .2 having successfully completed a training course meeting the training guidance established by the Organization for ships operating in polar waters.\*

7 Until 1 July 2020, seafarers who commenced approved seagoing service in polar waters prior to 1 July 2018 shall be able to establish that they meet the requirements of paragraph 4 by:

- .1 having completed approved seagoing service on board a ship operating in polar waters or equivalent approved seagoing service, performing duties in the deck department at management level, for a period of at least three months in total during the preceding five years; or
- .2 having successfully completed a training course meeting the training guidance established by the Organization for ships operating in polar waters\* and having completed approved seagoing service on board a ship operating in polar waters or equivalent approved seagoing service, performing duties in the deck department at the management level, for a period of at least two months in total during the preceding five years."

\*\*\*

---

\* Refer to section B-V/g of the STCW Code.

**ANNEX 9**

**RESOLUTION MSC.417(97)  
(adopted on 25 November 2016)**

**AMENDMENTS TO PART A OF THE SEAFARERS' TRAINING,  
CERTIFICATION AND WATCHKEEPING (STCW) CODE**

THE MARITIME SAFETY COMMITTEE,

RECALLING Article 28(b) of the Convention on the International Maritime Organization concerning the functions of the Committee,

RECALLING ALSO Article XII and regulation I/1.2.3 of the International Convention on Standards of Training, Certification and Watchkeeping for Seafarers, 1978 ("the Convention"), concerning the procedures for amending part A of the Seafarers' Training, Certification and Watchkeeping (STCW) Code,

NOTING that there will be a transitional period between the entry into force of the Polar Code and the amendments to the STCW Convention, and that section B-V/g of the STCW Code provides guidance regarding the training of masters and officers for ships operating in polar waters which should be applied by Administrations during the transitional period,

HAVING CONSIDERED, at its ninety-seventh session, amendments to part A of the STCW Code, proposed and circulated in accordance with Article XII(1)(a)(i) of the Convention,

1 ADOPTS, in accordance with Article XII(1)(a)(iv) of the Convention, amendments to the STCW Code, the text of which is set out in the annex to the present resolution;

2 DETERMINES, in accordance with Article XII(1)(a)(vii)(2) of the Convention, that the said amendments to the STCW Code shall be deemed to have been accepted on 1 January 2018, unless, prior to that date, more than one third of Parties or Parties the combined merchant fleets of which constitute not less than 50% of the gross tonnage of the world's merchant shipping of ships of 100 gross register tons or more, have notified the Secretary-General of the Organization that they object to the amendments;

3 INVITES Parties to note that, in accordance with Article XII(1)(a)(ix) of the Convention, the annexed amendments to the STCW Code shall enter into force on 1 July 2018 upon their acceptance in accordance with paragraph 2 above;

4 URGES Parties to implement the amendments to section A-I/11 and section A-V/4 at an early stage;

5 REQUESTS the Secretary-General, for the purposes of Article XII(1)(a)(v) of the Convention, to transmit certified copies of the present resolution and the text of the amendments contained in the annex to all Parties to the Convention;

6 REQUESTS ALSO the Secretary-General to transmit copies of this resolution and its annex to Members of the Organization, which are not Parties to the Convention.

ANNEX

**AMENDMENTS TO PART A OF THE SEAFARERS' TRAINING,  
CERTIFICATION AND WATCHKEEPING (STCW) CODE**

**CHAPTER I – General provisions**

1 In section A-I/11, after the existing paragraph 3, a new paragraph 4 is added as follows:

"4 Continued professional competence for masters and officers on board ships operating in polar waters, as required under regulation I/11, shall be established by:

- .1 approved seagoing service, performing functions appropriate to the certificate held, for a period of at least two months in total during the preceding five years; or
- .2 having performed functions considered to be equivalent to the seagoing service required in paragraph 4.1; or
- .3 passing an approved test; or
- .4 successfully completing an approved training course or courses."

2 In section A-I/14, after existing paragraph 3, a new paragraph 4 is added as follows:

"4 Companies shall ensure that masters and officers on board their passenger ships shall have completed familiarization training to attain the abilities that are appropriate to the capacity to be filled and duties and responsibilities to be taken up, taking into account the guidance given in section B-I/14, paragraph 3 of this Code."

**CHAPTER V – Standards regarding special training requirements for personnel on certain types of ships**

3 In chapter V, the existing section A-V/2 is replaced by the following:

**"Section A-V/2**

*Mandatory minimum requirements for the training and qualification of masters, officers, ratings and other personnel on passenger ships*

**Passenger ship emergency familiarization**

1 Before being assigned to shipboard duties, all personnel serving on board passenger ships engaged on international voyages shall have attained the abilities that are appropriate to their duties and responsibilities as follows:

*Contribute to the implementation of emergency plans, instructions and procedures*

- .1 Familiar with:
  - .1.1 general safety features aboard ship;



- .1.2 location of essential safety and emergency equipment, including life-saving appliances;
- .1.3 importance of personal conduct during an emergency; and
- .1.4 restrictions on the use of elevators during emergencies.

*Contribute to the effective communication with passengers during an emergency*

- .2 Ability to:
  - .2.1 communicate in the working language of the ship;
  - .2.2 non-verbally communicate safety information; and
  - .2.3 understand one of the languages in which emergency announcements may be broadcast on the ship during an emergency or drill.

**Safety training for personnel providing direct service to passengers in passenger spaces**

2 Before being assigned to shipboard duties, personnel providing direct service to passengers in passenger spaces shall receive the additional safety training required by regulation V/2, paragraph 6, that ensures at least the attainment of the abilities as follows:

*Communication*

- .1 Ability to communicate with passengers during an emergency, taking into account:
  - .1.1 the language or languages appropriate to the principal nationalities of passengers carried on the particular route;
  - .1.2 the likelihood that an ability to use an elementary English vocabulary for basic instructions can provide a means of communicating with a passenger in need of assistance whether or not the passenger and crew member share a common language;
  - .1.3 the possible need to communicate during an emergency by some other means, such as by demonstration, or hand signals, or calling attention to the location of instructions, muster stations, life-saving devices or evacuation routes, when oral communication is impractical;
  - 1.4 the extent to which complete safety instructions have been provided to passengers in their native language or languages; and
  - .1.5 the languages in which emergency announcements may be broadcast during an emergency or drill to convey critical guidance to passengers and to facilitate crew members in assisting passengers.

*Life-saving appliances*

- .2 Ability to demonstrate to passengers the use of personal life-saving appliances.

*Embarkation procedures*

- .3 Embarking and disembarking passengers, with special attention to disabled persons and persons needing assistance.

**Passenger ship crowd management training**

3 Before being assigned to shipboard duties, masters, officers, ratings qualified in accordance with chapters II, III and VII and personnel designated on the muster list to assist passengers in emergency situations shall:

- .1 have successfully completed the crowd management training required by regulation V/2, paragraph 7, as set out in table A-V/2-1; and
- .2 be required to provide evidence that the training has been completed in accordance with table A-V/2-1.

**Crisis management and human behaviour training**

4 Before being assigned to shipboard duties, masters, chief engineer officers, chief mates, second engineer officers and any person designated on the muster list as having responsibility for the safety of passengers in emergency situations shall:

- .1 have successfully completed the approved crisis management and human behaviour training required by regulation V/2, paragraph 8, as set out in table A-V/2-2; and
- .2 be required to provide evidence that the required standard of competence has been achieved in accordance with the methods and the criteria for evaluating competence tabulated in columns 3 and 4 of table A-V/2-2.

**Passenger safety, cargo safety and hull integrity training**

5 Before being assigned to shipboard duties, masters, chief engineer officers, chief mates, second engineer officers and every person assigned immediate responsibility for embarking and disembarking passengers, for loading, discharging or securing cargo, or for closing hull openings on board ro-ro passenger ships shall receive the passenger safety, cargo safety and hull integrity training required by regulation V/2, paragraph 9, that ensures at least attainment of the abilities that are appropriate to their duties and responsibilities as follows:

*Loading and embarkation procedures*

- .1 Ability to apply properly the procedures established for the ship regarding:
  - .1.1 loading and discharging vehicles, rail cars and other cargo transport units, including related communications;
  - .1.2 lowering and hoisting ramps;
  - .1.3 setting up and stowing retractable vehicle decks; and
  - .1.4 embarking and disembarking passengers, with special attention to disabled persons and persons needing assistance.

*Carriage of dangerous goods*

- .2 Ability to apply any special safeguards, procedures and requirements regarding the carriage of dangerous goods on board ro-ro passenger ships.

*Securing cargoes*

- .3 Ability to:
  - .3.1 apply correctly the provisions of the Code of Safe Practice for Cargo Stowage and Securing to the vehicles, rail cars and other cargo transport units carried; and
  - .3.2 use properly the cargo-securing equipment and materials provided, taking into account their limitations.

*Stability, trim and stress calculations*

- .4 Ability to:
  - .4.1 make proper use of the stability and stress information provided;
  - .4.2 calculate stability and trim for different conditions of loading, using the stability calculators or computer programs provided;
  - .4.3 calculate load factors for decks; and
  - .4.4 calculate the impact of ballast and fuel transfers on stability, trim and stress.

*Opening, closing and securing hull openings*

- .5 Ability to:
  - .5.1 apply properly the procedures established for the ship regarding the opening, closing and securing of bow, stern and side doors and ramps and to correctly operate the associated systems; and
  - .5.2 conduct surveys on proper sealing.

*Ro-ro deck atmosphere*

- .6 Ability to:
  - .6.1 use equipment, where carried, to monitor atmosphere in ro-ro spaces; and
  - .6.2 apply properly the procedures established for the ship for ventilation of ro-ro spaces during loading and discharging of vehicles, while on voyage and in emergencies.

**Table A-V/2-1**  
*Specification of minimum standard of competence in  
passenger ship crowd management training*

<b>Column 1</b>	<b>Column 2</b>	<b>Column 3</b>	<b>Column 4</b>
<b>Competence</b>	<b>Knowledge, understanding and proficiency</b>	<b>Methods for demonstrating competence</b>	<b>Criteria for evaluating competence</b>
Contribute to the implementation of shipboard emergency plans and procedures to muster and evacuate passengers	<p>Knowledge of the shipboard emergency plans, instructions and procedures related to the management and evacuation of passengers</p> <p>Knowledge of applicable crowd management techniques and relevant equipment to be used to assist passengers in an emergency situation</p> <p>Knowledge of muster lists and emergency instructions</p>	Assessment of evidence obtained from training and/or instruction	Actions taken in case of an emergency are appropriate and comply with established procedures
Assist passengers <i>en route</i> to muster and embarkation stations	<p>Ability to give clear reassuring orders</p> <p>Ability to manage passengers in corridors, staircases and passageways</p> <p>Understanding the importance of and having the ability to maintain escape routes clear of obstructions</p> <p>Knowledge of methods available for evacuation of disabled persons and persons needing special assistance</p> <p>Knowledge of methods of searching passenger accommodation and public spaces</p> <p>Ability to disembark passengers, with special attention to disabled persons and persons needing assistance</p> <p>Importance of effective mustering procedures, including:</p> <p>.1 the importance of keeping order;</p>	Assessment of evidence obtained from practical training and/or instruction	<p>Actions taken conform with emergency plans, instructions and procedures</p> <p>Information given to individuals, emergency response teams and passengers is accurate, relevant and timely</p>

Column 1	Column 2	Column 3	Column 4
<b>Competence</b>	<b>Knowledge, understanding and proficiency</b>	<b>Methods for demonstrating competence</b>	<b>Criteria for evaluating competence</b>
	.2 the ability to use procedures for reducing and avoiding panic;  .3 the ability to use, where appropriate, passenger lists for evacuation counts;  .4 the importance of passengers being suitably clothed as far as possible when mustering; and  .5 the ability to check that the passengers have donned their life jackets correctly.		

**Table A-V/2-2**  
*Specification of minimum standard of competence in  
passenger ship crisis management and human behaviour*

<b>Column 1</b>	<b>Column 2</b>	<b>Column 3</b>	<b>Column 4</b>
<b>Competence</b>	<b>Knowledge, understanding and proficiency</b>	<b>Methods for demonstrating competence</b>	<b>Criteria for evaluating competence</b>
Organize shipboard emergency procedures	<p>Knowledge of:</p> <ul style="list-style-type: none"> <li>.1 the general design and layout of the ship</li> <li>.2 safety regulations</li> <li>.3 emergency plans and procedures</li> </ul> <p>The importance of the principles for the development of ship-specific emergency procedures, including:</p> <ul style="list-style-type: none"> <li>.1 the need for pre-planning and drills of shipboard emergency procedures</li> <li>.2 the need for all personnel to be aware of and adhere to pre-planned emergency procedures as carefully as possible in the event of an emergency situation</li> </ul>	<p>Assessment of evidence obtained from approved training, exercises with one or more prepared emergency plans and practical demonstration</p>	<p>The shipboard emergency procedures ensure a state of readiness to respond to emergency situations</p>
Optimize the use of resources	<p>Ability to optimize the use of resources, taking into account:</p> <ul style="list-style-type: none"> <li>.1 the possibility that resources available in an emergency may be limited</li> <li>.2 the need to make full use of personnel and equipment immediately available and, if necessary, to improvise</li> </ul> <p>Ability to organize realistic drills to maintain a state of readiness, taking into account lessons learnt from previous accidents involving passenger ships; debriefing after drills</p>	<p>Assessment of evidence obtained from approved training, practical demonstration and shipboard training and drills of emergency procedures</p>	<p>Contingency plans optimize the use of available resources</p> <p>Allocation of tasks and responsibilities reflects the known competence of individuals</p> <p>Roles and responsibilities of teams and individuals are clearly defined</p>

Column 1	Column 2	Column 3	Column 4
Competence	Knowledge, understanding and proficiency	Methods for demonstrating competence	Criteria for evaluating competence
Control response to emergencies	<p>Ability to make an initial assessment and provide an effective response to emergency situations in accordance with established emergency procedures</p> <p><i>Leadership skills</i></p> <p>Ability to lead and direct others in emergency situations, including the need:</p> <ul style="list-style-type: none"> <li>.1 to set an example during emergency situations</li> <li>.2 to focus decision making, given the need to act quickly in an emergency</li> <li>.3 to motivate, encourage and reassure passengers and other personnel</li> </ul> <p><i>Stress handling</i></p> <p>Ability to identify the development of symptoms of excessive personal stress and those of other members of the ship's emergency team</p> <p>Understanding that stress generated by emergency situations can affect the performance of individuals and their ability to act on instructions and follow procedures</p>	Assessment of evidence obtained from approved training, practical demonstration and shipboard training and drills of emergency procedures	<p>Procedures and actions are in accordance with established principles and plans for crisis management on board</p> <p>Objectives and strategy are appropriate to the nature of the emergency, take account of contingencies and make optimum use of available resources</p> <p>Actions of crew members contribute to maintaining order and control</p>
Control passengers and other personnel during emergency situations	<p><i>Human behaviour and responses</i></p> <p>Ability to control passengers and other personnel in emergency situations, including:</p> <ul style="list-style-type: none"> <li>.1 awareness of the general reaction patterns of passengers and other personnel in emergency situations, including the possibility that:</li> </ul>	Assessment of evidence obtained from approved training, practical demonstration and shipboard training and drills of emergency procedures	Actions of crew members contribute to maintaining order and control



Column 1	Column 2	Column 3	Column 4
Competence	Knowledge, understanding and proficiency	Methods for demonstrating competence	Criteria for evaluating competence
	<p>.1.1 generally it takes some time before people accept the fact that there is an emergency situation</p> <p>.1.2 some people may panic and not behave with a normal level of rationality, that their ability to comprehend may be impaired and they may not be as responsive to instructions as in non-emergency situations</p> <p>.2 awareness that passengers and other personnel may, inter alia:</p> <p>.2.1 start looking for relatives, friends and/or their belongings as a first reaction when something goes wrong</p> <p>.2.2 seek safety in their cabins or in other places on board where they think that they can escape danger</p> <p>.2.3 tend to move to the upper side when the ship is listing</p> <p>.3 appreciation of the possible problem of panic resulting from separating families</p>		
<p>Establish and maintain effective communications</p>	<p>Ability to establish and maintain effective communications, including:</p> <p>.1 the importance of clear and concise instructions and reports</p> <p>.2 the need to encourage an exchange of information with, and feedback from, passengers and other personnel</p>	<p>Assessment of evidence obtained from approved training, exercises and practical demonstration</p>	<p>Information from all available sources is obtained, evaluated and confirmed as quickly as possible and reviewed throughout the emergency</p> <p>Information given to individuals, emergency response teams and</p>

Column 1	Column 2	Column 3	Column 4
Competence	Knowledge, understanding and proficiency	Methods for demonstrating competence	Criteria for evaluating competence
	<p>Ability to provide relevant information to passengers and other personnel during an emergency situation, to keep them apprised of the overall situation and to communicate any action required of them, taking into account:</p> <p>.1 the language or languages appropriate to the principal nationalities of passengers and other personnel carried on the particular route</p> <p>.2 the possible need to communicate during an emergency by some other means, such as by demonstration, or by hand signals or calling attention to the location of instructions, muster stations, life-saving devices or evacuation routes, when oral communication is impractical</p> <p>.3 the language in which emergency announcements may be broadcast during an emergency or drill to convey critical guidance to passengers and to facilitate crew members in assisting passengers</p>		<p>passengers is accurate, relevant and timely</p> <p>Information keeps passengers informed as to the nature of the emergency and the actions required of them</p>

4 A new section A-V/4 is added as follows:

**"Section A-V/4**

*Mandatory minimum requirements for the training and qualifications of masters and deck officers on ships operating in polar waters*

**Standard of competence**

1 Every candidate for certification in basic training for ships operating in polar waters shall be required to:

- .1 demonstrate the competence to undertake the tasks, duties and responsibilities listed in column 1 of table A-V/4-1; and

- .2 provide evidence of having achieved:
    - .1 the minimum knowledge, understanding and proficiency listed in column 2 of table A-V/4-1; and
    - .2 the required standard of competence in accordance with the methods for demonstrating competence and the criteria for evaluating competence tabulated in columns 3 and 4 of table A-V/4-1.
- 2 Every candidate for certification in advanced training for ships operating in polar waters shall be required to:
- .1 demonstrate the competence to undertake the tasks, duties and responsibilities listed in column 1 of table A-V/4-2; and
  - .2 provide evidence of having achieved:
    - .1 the minimum knowledge, understanding and proficiency listed in column 2 of table A-V/4-2; and
    - .2 the required standard of competence in accordance with the methods for demonstrating competence and the criteria for evaluating competence tabulated in columns 3 and 4 of table A-V/4-2.

**Table A-V/4-1**  
*Specification of minimum standard of competence in basic training  
for ships operating in polar waters*

<b>Column 1</b>	<b>Column 2</b>	<b>Column 3</b>	<b>Column 4</b>
<b>Competence</b>	<b>Knowledge, understanding and proficiency</b>	<b>Methods for demonstrating competence</b>	<b>Criteria for evaluating competence</b>
Contribute to safe operation of vessels operating in polar waters	<p><i>Basic knowledge of ice characteristics and areas where different types of ice can be expected in the area of operation:</i></p> <p>.1 ice physics, terms, formation, growth, ageing and stage of melt</p> <p>.2 ice types and concentrations</p> <p>.3 ice pressure and distribution</p> <p>.4 friction from snow covered ice</p> <p>.5 implications of spray-icing; danger of icing up; precautions to avoid icing up and options during icing up</p> <p>.6 ice regimes in different regions; significant differences between the Arctic and the Antarctic, first year and multiyear ice, sea ice and land ice</p> <p>.7 use of ice imagery to recognize consequences of rapid change in ice and weather conditions</p> <p>.8 knowledge of ice blink and water sky</p> <p>.9 knowledge of differential movement of icebergs and pack ice</p> <p>.10 knowledge of tides and currents in ice</p>	<p>Examination and assessment of evidence obtained from one or more of the following:</p> <p>.1 approved in-service experience</p> <p>.2 approved training ship experience</p> <p>.3 approved simulator training, where appropriate</p> <p>.4 approved training programme</p>	<p>Identification of ice properties and their characteristics of relevance for safe vessel operation</p> <p>Information obtained from ice information and publications is interpreted correctly and properly applied</p> <p>Use of visible and infrared satellite images</p> <p>Use of egg charts</p> <p>Coordination of meteorological and oceanographic data with ice data</p> <p>Measurements and observations of weather and ice conditions are accurate and appropriate for safe passage planning</p>

Column 1 Competence	Column 2 Knowledge, understanding and proficiency	Column 3 Methods for demonstrating competence	Column 4 Criteria for evaluating competence
	.11 knowledge of effect of wind and current on ice		
	<p><i>Basic knowledge of vessel performance in ice and low air temperature:</i></p> <p>.1 vessel characteristics</p> <p>.2 vessel types, hull designs</p> <p>.3 engineering requirements for operating in ice</p> <p>.4 Ice strengthening requirements</p> <p>.5 limitations of ice-classes</p> <p>.6 winterization and preparedness of vessel, including deck and engine</p> <p>.7 low-temperature system performance</p> <p>.8 equipment and machinery limitation in ice condition and low air temperature</p> <p>.9 monitoring of ice pressure on hull</p> <p>.10 sea suction, water intake, superstructure insulation and special systems</p>	<p>Examination and assessment of evidence obtained from one or more of the following:</p> <p>.1 approved in-service experience</p> <p>.2 approved training ship experience</p> <p>.3 approved simulator training, where appropriate</p> <p>.4 approved training programme</p>	<p>Identification of vessel characteristics and limitations under different ice conditions and cold environmental impact</p> <p>Procedures are made for risk assessment before entering ice</p> <p>Awareness of fresh water ballast freezing in ballast tanks</p> <p>Actions are carried out in accordance with accepted principles and procedures to prepare the vessel and the crew for operations in ice and low air temperature</p> <p>Communications are clear, concise and effective at all times in a seamanlike manner</p>
	<p><i>Basic knowledge and ability to operate and manoeuvre a vessel in ice:</i></p> <p>.1 safe speed in the presence of ice and icebergs</p> <p>.2 ballast tank monitoring</p>	<p>Examination and assessment of evidence obtained from one or more of the following:</p>	<p>Use Polar Code and Polar Water Operations Manual to correctly determine the recommended procedures to load/unload cargo and/or embark/disembark passengers in low</p>

Column 1 Competence	Column 2 Knowledge, understanding and proficiency	Column 3 Methods for demonstrating competence	Column 4 Criteria for evaluating competence
	<p>.3 cargo operations in polar waters</p> <p>.4 awareness of engine loads and cooling problems</p> <p>.5 safety procedures during ice transit</p>	<p>.1 approved in-service experience</p> <p>.2 approved training ship experience</p> <p>.3 approved simulator training, where appropriate</p> <p>.4 approved training programme</p>	<p>temperatures, monitor ballast water for icing, monitor engine temperatures, anchor watch concerns in ice, and transit near ice</p> <p>Interpretation and analysis of information from radar is in accordance with lookout procedures with special caution regarding identification of dangerous ice features</p> <p>Information obtained from navigational charts, including electronic charts, and publications is relevant, assessed, interpreted correctly and properly applied</p> <p>The primary method of position fixing is frequent and the most appropriate for the prevailing conditions and routing through ice</p> <p>Performance checks and tests of navigation and communication systems comply with recommendations for high latitude and low air temperature operation</p>

Column 1 Competence	Column 2 Knowledge, understanding and proficiency	Column 3 Methods for demonstrating competence	Column 4 Criteria for evaluating competence
Monitor and ensure compliance with legislative requirements	<p><i>Basic knowledge of regulatory considerations:</i></p> <ul style="list-style-type: none"> <li>.1 Antarctic Treaty and the Polar Code</li> <li>.2 accident reports concerning vessels in polar waters</li> <li>.3 IMO standards for operation in remote areas</li> </ul>	<p>Examination and assessment of evidence obtained from one or more of the following:</p> <ul style="list-style-type: none"> <li>.1 approved in-service experience</li> <li>.2 approved training ship experience</li> <li>.3 approved simulator training, where appropriate</li> <li>.4 approved training programme</li> </ul>	<p>Locate and apply relevant parts of the Polar Water Operations Manual</p> <p>Communication is in accordance with local/regional and international standard procedures</p> <p>Legislative requirements related to relevant regulations, codes and practices are identified</p>
Apply safe working practices, respond to emergencies	<p><i>Basic knowledge of crew preparation, working conditions and safety:</i></p> <ul style="list-style-type: none"> <li>.1 recognize limitations of search and rescue readiness and responsibility, including sea area A4 and its SAR communication facility limitation</li> <li>.2 awareness of contingency planning</li> <li>.3 how to establish and implement safe working procedures for crew specific to polar environments such as low temperatures, ice-covered surfaces, personal protective equipment, use of buddy system, and working time limitations</li> <li>.4 recognize dangers when crews are exposed to low temperatures</li> </ul>	<p>Examination and assessment of evidence obtained from one or more of the following:</p> <ul style="list-style-type: none"> <li>.1 approved in-service experience</li> <li>.2 approved training ship experience</li> <li>.3 approved simulator training, where appropriate</li> <li>.4 approved training programme</li> </ul>	<p>Identification and initial actions on becoming aware of hazardous situations for vessel and individual crew members</p> <p>Actions are carried out in accordance with Polar Water Operations Manual, accepted principles and procedures to ensure safety of operations and to avoid pollution of the marine environment</p> <p>Safe working practices are observed and appropriate safety and protective equipment is correctly used at all times</p> <p>Response actions are in accordance with established plans and are appropriate to the situation and nature of the emergency</p>

<b>Column 1 Competence</b>	<b>Column 2 Knowledge, understanding and proficiency</b>	<b>Column 3 Methods for demonstrating competence</b>	<b>Column 4 Criteria for evaluating competence</b>
	<p>.5 human factors including cold fatigue, medical-first aid aspects, crew welfare</p> <p>.6 survival requirements including the use of personal survival equipment and group survival equipment</p> <p>.7 awareness of the most common hull and equipment damages and how to avoid these</p> <p>.8 superstructure-deck icing, including effect on stability and trim</p> <p>.9 prevention and removal of ice including the factors of accretion</p> <p>.10 recognize fatigue problems due to noise and vibrations</p> <p>.11 identify need for extra resources, such as bunker, food and extra clothing</p>		<p>Correctly identifies and applies legislative requirements related to relevant regulations, codes and practices</p> <p>Appropriate safety and protective equipment is correctly used</p> <p>Defects and damages are detected and properly reported</p>



Column 1 Competence	Column 2 Knowledge, understanding and proficiency	Column 3 Methods for demonstrating competence	Column 4 Criteria for evaluating competence
<p>Ensure compliance with pollution-prevention requirements and prevent environmental hazards</p>	<p><i>Basic knowledge of environmental factors and regulations:</i></p> <ul style="list-style-type: none"> <li>.1 identify particularly sensitive sea areas regarding discharge</li> <li>.2 identify areas where shipping is prohibited or should be avoided</li> <li>.3 special areas defined in MARPOL</li> <li>.4 recognize limitations of oil-spill equipment</li> <li>.5 plan for coping with increased volumes of garbage, bilge water, sewage, etc.</li> <li>.6 lack of infrastructure</li> <li>.7 oil spill and pollution in ice, including consequences</li> </ul>	<p>Examination and assessment of evidence obtained from one or more of the following:</p> <ul style="list-style-type: none"> <li>.1 approved in-service experience</li> <li>.2 approved training ship experience</li> <li>.3 approved simulator training, where appropriate</li> <li>.4 approved training programme</li> </ul>	<p>Legislative requirements related to relevant regulations, codes and practices are identified</p> <p>Correctly identify/select the limitations on vessel discharges contained in the Polar Code</p> <p>Correctly apply Polar Water Operations Manual/Waste Management Plan to determine limitations on vessel discharges and plans for storing waste</p> <p>Identify references that provide details of areas to be avoided, such as wildlife refuges, ecological heritage parks, migratory pathways, etc. (MARPOL, Antarctic Treaty, etc.)</p> <p>Identify factors that must be considered to manage waste stream during polar voyages</p>

**Table A-V/4-2**  
*Specification of minimum standard of competence in advanced training  
for ships operating in polar waters*

<b>Column 1</b>	<b>Column 2</b>	<b>Column 3</b>	<b>Column 4</b>
<b>Competence</b>	<b>Knowledge, understanding and proficiency</b>	<b>Methods for demonstrating competence</b>	<b>Criteria for evaluating competence</b>
Plan and conduct a voyage in polar waters	<p><i>Knowledge of voyage planning and reporting:</i></p> <p>.1 information sources</p> <p>.2 reporting regimes in polar waters</p> <p>.3 development of safe routing and passage planning to avoid ice where possible</p> <p>.4 ability to recognize the limitations of hydrographic information and charts in polar regions and whether the information is suitable for safe navigation</p> <p>.5 passage planning deviation and modification for dynamic ice conditions</p> <p><i>Knowledge of equipment limitations:</i></p> <p>.1 understand and identify hazards associated with limited terrestrial navigational aids in polar regions</p> <p>.2 understand and recognize high latitude errors on compasses</p> <p>.3 understand and identify limitations in discrimination</p>	<p>Examination and assessment of evidence obtained from one or more of the following:</p> <p>.1 approved in-service experience</p> <p>.2 approved training ship experience</p> <p>.3 approved simulator training, where appropriate</p> <p>.4 approved training programme</p>	<p>The equipment, charts and nautical publications required for the voyage are enumerated and appropriate to the safe conduct of the voyage</p> <p>The reasons for the planned route are supported by facts obtained from relevant sources and publications, statistical data and limitations of communication and navigational systems</p> <p>Voyage plan correctly identified relevant polar regulatory regimes and need for ice-pilotage and/or icebreaker assistance</p> <p>All potential navigational hazards are accurately identified</p> <p>Positions, courses, distances and time calculations are correct within accepted accuracy standards for navigational equipment</p>

Column 1	Column 2	Column 3	Column 4
Competence	Knowledge, understanding and proficiency	Methods for demonstrating competence	Criteria for evaluating competence
	<p>of radar targets and ice features in ice-clutter</p> <p>.4 understand and recognize limitations of electronic positioning systems at high latitude</p> <p>.5 understand and recognize limitations in nautical charts and pilot descriptions</p> <p>.6 understand and recognize limitations in communication systems</p>		
<p>Manage the safe operation of vessels operating in polar waters</p>	<p><i>Knowledge and ability to operate and manoeuvre a vessel in ice:</i></p> <p>.1 preparation and risk assessment before approaching ice, including presence of icebergs, and taking into account wind, darkness, swell, fog and pressure ice</p> <p>.2 conduct communications with an icebreaker and other vessels in the area and with Rescue Coordination Centres</p> <p>.3 understand and describe the conditions for the safe entry and exit to and from ice or open water, such as leads or cracks, avoiding icebergs and dangerous ice conditions and</p>	<p>Examination and assessment of evidence obtained from one or more of the following:</p> <p>.1 approved in-service experience</p> <p>.2 approved training ship experience</p> <p>.3 approved simulator training, where appropriate</p> <p>.4 approved training programme</p>	<p>All decisions concerning navigating in ice are based on a proper assessment of the ship's manoeuvring and engine characteristics and the forces to be expected while navigating within polar waters</p> <p>Demonstrate communication skills, request ice routing, plot and commence voyage through ice</p> <p>All potential ice hazards are correctly identified</p> <p>All decisions concerning berthing anchoring, cargo and ballast operations are based on a proper</p>

<b>Column 1 Competence</b>	<b>Column 2 Knowledge, understanding and proficiency</b>	<b>Column 3 Methods for demonstrating competence</b>	<b>Column 4 Criteria for evaluating competence</b>
	<p>maintaining safe distance to icebergs</p> <p>.4 understand and describe ice-ramming procedures including double and single ramming passage</p> <p>.5 recognize and determine the need for bridge watch team augmentation based upon environmental conditions, vessel equipment and vessel ice class</p> <p>.6 recognize the presentations of the various ice conditions as they appear on radar</p> <p>.7 understand icebreaker convoy terminology, and communications, and take icebreaker direction and move in convoy</p> <p>.8 understand methods to avoid besetment and to free beset vessel, and consequences of besetment</p> <p>.9 understand towing and rescue in ice, including risks associated with operation</p> <p>.10 handling ship in various ice concentration and</p>		<p>assessment of the ship's manoeuvring and engine characteristics and the forces to be expected and in accordance with the Polar Code guidelines and applicable international agreements</p> <p>Safely demonstrate progression of a vessel through ice, manoeuvring vessel through moderate ice concentration (range of 1/10 to 5/10)</p> <p>Safely demonstrate progression of a vessel through ice, manoeuvring vessel through dense ice concentration (range of 6/10 to 10/10)</p> <p>Operations are planned and carried out in accordance with established rules and procedures to ensure safety of operation and to avoid pollution of the marine environment</p> <p>Safety of navigation is maintained through navigation strategy and adjustment of ship's speed and heading through different types of ice</p>

Column 1	Column 2	Column 3	Column 4
Competence	Knowledge, understanding and proficiency	Methods for demonstrating competence	Criteria for evaluating competence
	<p>coverage, including risks associated with navigation in ice, e.g. avoid turning and backing simultaneously</p> <p>.11 use of different type of propulsion and rudder systems, including limitations to avoid damage when operating in ice</p> <p>.12 use of heeling and trim systems, hazards in connection with ballast and trim in relation with ice</p> <p>.13 docking and undocking in ice-covered waters, including hazards associated with operation and the various techniques to safely dock and undock in ice-covered waters</p> <p>.14 anchoring in ice, including the dangers to anchoring system – ice accretion to hawse pipe and ground tackle</p> <p>.15 recognize conditions which impact polar visibility and may give indication of local ice and water conditions, including sea smoke, water sky, ice blink and refraction</p>		<p>Actions are understood to permit use of anchoring system in cold temperatures</p> <p>Actions are carried out in accordance with accepted principles and procedures to prepare for icebreaker towing, including notch towing</p>

Column 1 Competence	Column 2 Knowledge, understanding and proficiency	Column 3 Methods for demonstrating competence	Column 4 Criteria for evaluating competence
<p>Maintain safety of the ship's crew and passengers and the operational condition of life-saving, fire-fighting and other safety systems</p>	<p><i>Knowledge of safety:</i></p> <p>.1 understand the procedures and techniques for abandoning the ship and survival on ice and in ice-covered waters</p> <p>.2 recognize limitations of fire-fighting systems and life-saving appliances due to low air temperatures</p> <p>.3 understand unique concerns in conducting emergency drills in ice and low temperatures</p> <p>.4 understand unique concerns in conducting emergency response in ice and low air and water temperatures</p>	<p>Examination and assessment of evidence obtained from one or more of the following:</p> <p>.1 approved in-service experience</p> <p>.2 approved training ship experience</p> <p>.3 approved simulator training, where appropriate</p> <p>.4 approved training programme</p>	<p>Response measures are in accordance with established plans and procedures, and are appropriate to the situation and nature of the emergency</p>

"

\*\*\*

## **ANNEX 10**

### **DRAFT AMENDMENTS TO THE INTERNATIONAL CODE OF SAFETY FOR SHIPS USING GASES OR OTHER LOW-FLASHPOINT FUELS (IGF CODE)**

#### **CHAPTER 11 FIRE SAFETY**

##### **11.3 Regulations for fire protection**

1 In paragraph 11.3.2, the words "and any boundaries above that, including navigation bridge windows, shall have A-0 class divisions" are deleted.

\*\*\*

---

**ANNEX 13**

**DRAFT AMENDMENTS TO SOLAS REGULATION II-2/9.4.1.3<sup>1</sup>**

**CHAPTER II-2  
CONSTRUCTION – FIRE PROTECTION, FIRE DETECTION AND FIRE EXTINCTION**

**PART C  
SUPPRESSION OF FIRE**

**Regulation 9 – Containment of fire**

- 1 The following new paragraphs 4.1.3.4 to 4.1.3.6 are added after the existing paragraph 4.1.3.3:

"4.1.3.4 Notwithstanding the requirement in paragraph 4.1.3.3, the requirements in paragraphs 4.1.3.5 and 4.1.3.6 shall apply to ships constructed on or after [*date of entry into force*].

4.1.3.5 For ships carrying more than 36 passengers, windows facing survival craft, embarkation and assembly stations, external stairs and open decks used for escape routes, and windows situated below liferaft and escape slide, embarkation areas shall have fire integrity as required in table 9.1. Where automatic dedicated sprinkler heads are provided for windows, "A-0" windows may be accepted as equivalent. To be considered under this paragraph, the sprinkler heads must either be:

- .1 dedicated heads located above the windows, and installed in addition to the conventional ceiling sprinklers; or
- .2 conventional ceiling sprinkler heads arranged such that the window is protected by an average application rate of at least 5 l/min per square metre and the additional window area is included in the calculation of the area of coverage; or
- .3 water-mist nozzles that have been tested and approved in accordance with the guidelines approved by the Organization\*; and

Windows located in the ship's side below the lifeboat embarkation area shall have fire integrity at least equal to "A-0" class.

4.1.3.6 For ships carrying not more than 36 passengers, windows facing survival craft and escape slide, embarkation areas and windows situated below such areas shall have fire integrity at least equal to "A-0" class.

---

\* Refer to the *Revised guidelines for approval of sprinkler systems equivalent to that referred to in SOLAS regulation II-2/12 (resolution A.800(19), as amended).*"

\*\*\*

---

<sup>1</sup> Tracked changes are created using "strikeout" for deleted text and "grey shading" to highlight all modifications and new insertions, including deleted text.



## **ANNEX 19**

### **DRAFT AMENDMENTS TO PARAGRAPHS 4.5.1 AND 4.5.2 OF THE IMSBC CODE**

#### **SECTION 4**

##### **ASSESSMENT OF ACCEPTABILITY OF CONSIGNMENTS FOR SAFE SHIPMENT**

#### **4.5 Interval between sampling/testing and loading for TML and moisture content determination**

- 1 Replace the existing paragraphs 4.5.1 and 4.5.2 with the following:

"4.5.1 The shipper shall be responsible for ensuring that a test to determine the TML of a solid bulk cargo is conducted within six months to the date of loading the cargo. Notwithstanding this provision, where the composition or characteristics of the cargo are variable for any reason, the shipper shall be responsible for ensuring that a test to determine the TML is conducted again after it is reasonably assumed that such variation has taken place.

4.5.2 The shipper shall be responsible for ensuring that sampling and testing for moisture content is conducted as near as practicable to the date of commencement of loading. The interval between sampling/testing and the date of commencement of loading shall never be more than seven days. If the cargo has been exposed to significant rain or snow between the time of testing and the date of completion of loading, the shipper shall be responsible for ensuring that the moisture content of the cargo is still less than its TML, and evidence of this is provided to the master as soon as practicable."

\*\*\*

**ANNEX 20**

**DRAFT AMENDMENTS TO SOLAS REGULATION II-2/20.2**

**CHAPTER II-2  
CONSTRUCTION – FIRE PROTECTION, FIRE DETECTION AND FIRE EXTINCTION**

**PART G  
SPECIAL REQUIREMENTS**

**Regulation 20 – Protection of vehicle, special category and ro-ro spaces**

1 The existing paragraph under 2.1 is numbered as 2.1.1 and the following new paragraph 2.1.2 is added after paragraph 2.1.1:

"2.1.2 Notwithstanding the above, cargo spaces on all ships, which contain vehicles with fuel in their tanks for their own propulsion that are loaded/unloaded into spaces which do not meet the requirements of this regulation and which do not use their own propulsion within the cargo space, are not required to comply with this regulation, providing the vehicles are carried in compliance with the appropriate requirements of regulation 19 and the IMDG Code, as defined in regulation VII/1.1."

\*\*\*

4 ALBERT EMBANKMENT  
LONDON SE1 7SR  
Telephone: +44 (0)20 7735 7611 Fax: +44 (0)20 7587 3210

MSC.1/Circ.1460/Rev.1  
25 November 2016

## **GUIDANCE ON THE VALIDITY OF RADIOCOMMUNICATIONS EQUIPMENT INSTALLED AND USED ON SHIPS**

1 The Maritime Safety Committee, at its ninety-second session (12 to 21 June 2013), taking into account the recommendation of the Sub-Committee on Radiocommunications and Search and Rescue at its seventeenth session (21 to 25 January 2013), having recognized concerns that incompatibility may exist between radiocommunication equipment installed on ships, and the revised frequencies and channelling arrangements for the maritime HF and VHF bands as contained in appendices 17 and 18 to the Radio Regulations (RR) – Edition 2012, approved the *Guidance on the validity of radiocommunications equipment installed and used on ships* (MSC.1/Circ.1460).

2 The Maritime Safety Committee, at its ninety-seventh session (21 to 25 November 2016), while noting that a revision of this circular was anticipated in parallel with the upcoming revision of SOLAS chapter IV, agreed to amend the date from 1 January 2017 to 1 January 2024 (paragraph 7 below), with the intention of avoiding any unnecessary updates of HF radiocommunication equipment that is already capable of operating narrow band direct printing (NBDP).

3 The World Radiocommunication Conference 2012 made extensive changes to appendices 17 and 18 of the RR. Whilst these changes do not affect the GMDSS, they do affect the use of other frequencies that would be used by services such as Port Operations and VTS.

4 The RR provisions apply as from the dates of application indicated in article 59 and resolution 98 of the RR. Timely action is required by ships to ensure that radiocommunication equipment complies with the RR. Replacement of operating hardware may be necessary to meet the changed requirements.

5 According to the *Performance standards for shipborne VHF radio installations capable of communication and digital selective calling* (resolution A.803(19)), the equipment should comply with the Radio Regulations.

6 Attention is drawn to MSC.1/Circ.1389, which contains *Guidance on procedures for updating shipborne navigation and communication equipment*, and that updates to application software and firmware to meet changes in IMO and ITU regulatory requirements were needed.

7 To ensure GMDSS communication capability, HF radiocommunication equipment capable of operating narrow-band direct printing (NBDP) should be updated so that, following the first radio survey after 1 January 2024, it meets the channelling arrangements reflected in sections II and III of part B in appendix 17 of the RR.

8 Radiocommunication equipment, other than HF radiocommunication equipment capable of operating NBDP, does not necessarily need to be updated by the first radio survey after 1 January 2017, but may be updated appropriately in accordance with the decisions of the Administration.

9 Member States are invited to bring this information to the attention of the appropriate national authorities and all other parties concerned.

---

---

4 ALBERT EMBANKMENT  
LONDON SE1 7SR  
Telephone: +44 (0)20 7735 7611 Fax: +44 (0)20 7587 3210

MSC.1/Circ.1490/Rev.1  
25 November 2016

**REVISED UNIFIED INTERPRETATION OF  
SOLAS REGULATION III/31.1.4 (MSC.1/CIRC.1490)**

1 The Maritime Safety Committee, at its ninety-seventh session (21 to 25 November 2016), with a view to providing more specific guidance on arrangements for remotely located survival craft, approved a unified interpretation of SOLAS regulation III/31.1.4, prepared by the Sub-Committee on Ship Systems and Equipment at its third session (14 to 18 March 2016), as set out in the annex.

2 Member States are invited to use the annexed revised unified interpretation as guidance when applying SOLAS regulation III/31.1.4 to the liferafts to be installed on board ships constructed on or after 21 November 2014 and to bring the unified interpretation to the attention of all parties concerned.

3 This circular supersedes MSC.1/Circ.1490.

\*\*\*

## ANNEX

### REVISED UNIFIED INTERPRETATION OF SOLAS REGULATION III/31.1.4 (MSC.1/CIRC.1490)

#### Arrangements for remotely located survival craft

1 Liferafts required by SOLAS regulation III/31.1.4 should be regarded as "remotely located survival craft" with regard to SOLAS regulation III/7.2.1.4.

2 The area where these remotely located survival craft are stowed should be provided with:

- .1 a minimum number of two lifejackets and two immersion suits;
- .2 adequate means of illumination complying with SOLAS regulation III/16.7, either fixed or portable, which should be capable of illuminating the liferaft stowage position, as well as the area of water into which the liferaft should be launched; portable lights, when used, should have brackets to permit their positioning on both sides of the vessel;
- .3 an embarkation ladder or other means of embarkation enabling descent to the water in a controlled manner\* as per SOLAS regulation III/11.7; and
- .4 self-contained battery-powered lamps (i.e. luminaires) may be accepted as means of illumination for complying with SOLAS regulation III/16.7. Such lamps should be capable of being recharged from the ship's main and emergency source of electrical power, and should be stowed close to the liferaft and embarkation ladder they are intended to serve, under charge. When disconnected from the ship's power, the lamp should give a minimum duration of three hours of undiminished performance. The lamps should comply with the requirements of section 1.2.3 of the LSA Code. The lamps (i.e. luminaires) should meet the requirements of Ingress Protection rating IP 55. The batteries for the subject lamps should comply with IACS Unified Requirement (UR) E18 requirements irrespective of whether the expiry date is marked by the manufacturer or not.

3 With regard to the distance between the embarkation station and stowage location of the liferaft as required by SOLAS regulation III/31.1.4 (remotely located survival craft), the embarkation station should be so arranged that the requirements of regulation III/13.1.3 can be satisfied.

4 Exceptionally, the embarkation station and stowage position of the liferaft (remotely located survival craft) may be located on different decks provided that the liferaft can be launched from the stowage deck using the attached painter to relocate it to the embarkation ladder positioned on the other deck (traversing a stairway between different decks with the liferaft carried by crew members is not acceptable).

---

\* Controlled manner: a knotted rope is not acceptable for this purpose.

5 Notwithstanding paragraph 2, where the exceptional cases mentioned in paragraph 4 exist, the following provisions should be applied:

- .1 the lifejackets and the immersion suits required by paragraph 2.1 may be stowed at the embarkation station;
- .2 adequate means of illumination complying with paragraph 2.2 should also illuminate the liferaft stowage position, embarkation station and area of water where the liferaft is to be embarked;
- .3 the embarkation ladder or other means of embarkation as required by paragraph 2.3 may be stowed at the embarkation station; and
- .4 notwithstanding the requirements in paragraph 4.1.3.2 of the LSA Code, the painter should be long enough to reach the relevant embarkation station.

---

---

4 ALBERT EMBANKMENT  
LONDON SE1 7SR  
Telephone: +44 (0)20 7735 7611 Fax: +44 (0)20 7587 3210

MSC.1/Circ.1495/Rev.1  
25 November 2016

**REVISED UNIFIED INTERPRETATION OF SOLAS REGULATION V/23.3.3  
ON PILOT TRANSFER ARRANGEMENTS**

- 1 The Maritime Safety Committee, at its ninety-seventh session (21 to 25 November 2016), approved a *Revised unified interpretation of SOLAS regulation V/23.3.3 on Pilot transfer arrangements*, prepared by the Sub-Committee on Navigation, Communications and Search and Rescue (NCSR), at its third session, as set out in the annex.
- 2 Member States are invited to use the unified interpretation as guidance when applying the relevant provisions of SOLAS regulation V/23.3.3 for pilot transfer equipment and arrangements, and to bring this unified interpretation to the attention of all parties concerned.
- 3 This circular supersedes MSC.1/Circ.1495.

\*\*\*



## ANNEX

### UNIFIED INTERPRETATION OF SOLAS REGULATION V/23.3.3 ON PILOT TRANSFER ARRANGEMENTS

#### SOLAS regulation V/23.3.3 states:

*Safe and convenient access to, and egress from, the ship shall be provided by either:*

- .1 a pilot ladder requiring a climb of not less than 1.5 m and not more than 9 m above the surface of the water so positioned and secured that:
  - .1.4 the single length of pilot ladder is capable of reaching the water from the point of access to, or egress from, the ship and due allowance is made for all conditions of loading and trim of the ship, and for an adverse list of 15°; the securing strong point, shackles and securing ropes shall be at least as strong as the side ropes; or**
- .2 an accommodation ladder in conjunction with the pilot ladder (i.e. a combination arrangement), or other equally safe and convenient means, whenever the distance from the surface of the water to the point of access to the ship is more than 9 m.*

#### Interpretation

Subparagraphs 1 and 2 of SOLAS regulation V/23.3.3. address two different and distinct arrangements – the former when only a pilot ladder is provided; the latter when a combined arrangement of "an accommodation ladder used in conjunction with the pilot ladder" is provided.

1 SOLAS regulation V/23.3.3.1 prescribes an operational instruction that limits the climb to not more than 9 m on a single ladder regardless of the trim or list of the ship.

2 SOLAS regulation V/23.3.3.2 and section 3 of resolution A.1045(27) applies to a combined arrangement of "an accommodation ladder used in conjunction with the pilot ladder" for "Safe and convenient access to, and egress from, the ship" for which a 15° list requirement does not apply.

3 Member States are invited to use the unified interpretation provided in paragraphs 1 and 2 above as guidance when applying the relevant provisions of SOLAS regulation V/23.3.3 for pilot transfer equipment and arrangements and to bring them to the attention of all parties concerned.

---

4 ALBERT EMBANKMENT  
LONDON SE1 7SR  
Telephone: +44 (0)20 7735 7611 Fax: +44 (0)20 7587 3210

MSC.1/Circ.1549  
28 November 2016

## **NOTIFICATION OF AMENDMENTS TO PARAGRAPH 3.2.5 OF THE IGC CODE**

1 The Maritime Safety Committee, at its ninety-seventh session (21 to 25 November 2016), adopted, by resolution MSC.411(97), the following amendment to the International Code for the Construction and Equipment of Ships Carrying Liquefied Gases in Bulk (IGC Code), as amended by resolution MSC.370(93), to correct paragraph 3.2.5 by removing the requirement for fire-rated wheelhouse windows as follows:

In paragraph 3.2.5, the words "Wheelhouse windows shall be constructed to not less than "A-0" class (for external fire load)." are deleted.

2 In view of the above amendment which is expected to enter into force on 1 January 2020, Member States are invited to take action, as appropriate, pending its formal entry into force.

3 Member States are invited to bring the above information to the attention of all parties concerned.

4 This circular will remain effective until 1 January 2020.

---

---

4 ALBERT EMBANKMENT  
LONDON SE1 7SR  
Telephone: +44 (0)20 7735 7611 Fax: +44 (0)20 7587 3210

MSC.1/Circ.1555  
25 November 2016

## **UNIFIED INTERPRETATIONS OF SOLAS CHAPTER II-2**

1 The Maritime Safety Committee, at its ninety-seventh session (21 to 25 November 2016), with a view to providing more specific guidance on the definition of vehicle carrier; suitable connections for the supply of inert gas to double-hull spaces; ventilation provided by fan coil units and internal circulation fans; the fire integrity of the bulkheads between the wheelhouse and a toilet inside the wheelhouse; the suitable number of spare air cylinders to be provided in connection with drills; and sources of ignition on board ships carrying dangerous goods, approved unified interpretations of SOLAS chapter II-2, prepared by the Sub-Committee on Ship Systems and Equipment at its third session (14 to 18 March 2016), as set out in the annex.

2 Member States are invited to use the annexed unified interpretations as guidance when applying SOLAS regulations II-2/3 to II-2/5, II-2/7, II-2/9, II-2/15, II-2/19 and II-2/20-1, and to bring the unified interpretations to the attention of all parties concerned.

\*\*\*

## ANNEX

### UNIFIED INTERPRETATIONS OF SOLAS CHAPTER II-2

#### **SOLAS REGULATIONS II-2/3.56 AND II-2/20-1, AS AMENDED BY RESOLUTION MSC.365(93)**

##### **Definition of vehicle carrier**

The definition of vehicle carrier in SOLAS regulation II-2/3.56 is intended for pure car and truck carriers, and should exclude other types of ro-ro cargo ships or container/ro-ro ships, even when carrying empty cars and trucks as cargo.

#### **SOLAS REGULATION II-2/4.5.5.1, AS AMENDED BY RESOLUTION MSC.365(93)**

##### **Inert gas supply to double-hull spaces**

Double-hull spaces required to be fitted with suitable connections for the supply of inert gas as per SOLAS regulation II-2/4.5.5.1.4.1 are all ballast tanks and void spaces of double-hull and double-bottom spaces adjacent to the cargo tanks, including the forepeak tank and any other tanks and spaces under the bulkhead deck adjacent to cargo tanks, except cargo pump-rooms and ballast pump-rooms.

#### **SOLAS REGULATIONS II-2/5.2.1.2, II-2/5.2.1.3 AND II-2/7.9.3**

##### **Ventilation by fan coil units and internal circulation fans**

The fan in a heat, ventilation and air conditioning (HVAC) temperature control unit, or a circulation fan inside a cabinet/switchboard, is not considered to be a ventilation fan as addressed in SOLAS regulations II-2/5.2.1.2, II-2/5.2.1.3 and II-2/7.9.3, if it is not capable of supplying outside air to the space when the power ventilation is shut down (e.g. small units intended for recirculation of air within a cabin). Therefore, such fans need not be capable of being stopped from an easily accessible position (or a safe position) outside the space being served when applying SOLAS regulations II-2/5.2.1.2 or II-2/5.2.1.3, and need not be capable of being controlled from a continuously manned central control station for passenger ships carrying more than 36 passengers when applying SOLAS regulation II-2/7.9.3.

#### **SOLAS REGULATION II-2/9**

##### **Bulkhead between the wheelhouse and toilet inside the wheelhouse**

A bulkhead separating the wheelhouse and the toilet, installed completely within the wheelhouse, requires no fire rating.

#### **SOLAS REGULATION II-2/15.2.2.6, AS INTRODUCED BY RESOLUTION MSC.338(91)**

##### **Suitable number of spare air cylinders to be provided in connection with drills**

1 "A suitable number of spare cylinders" to be carried on board to replace those used for fire drills should be at least one "set of cylinders" for each mandatory breathing apparatus, unless additional spare cylinders are required by the shipboard safety management system (SMS).

2 "Set of cylinders" means the number of cylinders which are required to operate the breathing apparatus.

3 No additional cylinders are required for fire drills for breathing apparatus sets required by SOLAS regulation II-2/19, IMSBC Code, the IBC Code or IGC Code.

### **SOLAS REGULATION II-2/19.3.2**

#### **Certified safe type electrical equipment for ships carrying dangerous goods**

1 Reference should be made to IEC 60092-506:2003 standard, Electrical installations in ships – Part 506: Special features – Ships carrying specific dangerous goods and materials hazardous only in bulk.

2 For pipes having open ends (e.g. ventilation and bilge pipes) in a hazardous area, the pipe itself should be classified as a hazardous area (see IEC 60092-506:2003 table B1, item B).

3 When carrying flammable liquids having flashpoints less than 23°C as Class 3, Class 6.1 or Class 8 in cargo spaces, the bilge pipes with flanges, valves, pumps, etc. constitute a source of release and the enclosing spaces (e.g. pipe tunnels, bilge pump-rooms) should be classified as an extended hazardous area (comparable with zone 2) unless these spaces are continuously mechanically ventilated with a capacity for at least six air changes per hour. Except where the space is protected with redundant mechanical ventilation capable of starting automatically, equipment not certified for zone 2 should be automatically disconnected following loss of ventilation while essential systems such as bilge and ballast systems should be certified for zone 2. Where redundant mechanical ventilation is employed, equipment and essential systems not certified for zone 2 should be interlocked so as to prevent inadvertent operation if the ventilation is not operational. Audible and visible alarms should be provided at a manned station if failure occurs.

---

4 ALBERT EMBANKMENT  
LONDON SE1 7SR  
Telephone: +44 (0)20 7735 7611 Fax: +44 (0)20 7587 3210

MSC.1/Circ.1561  
28 November 2016

### **UNIFIED INTERPRETATION OF SOLAS REGULATION XI-1/7**

1 The Maritime Safety Committee, at its ninety-seventh session (21 to 25 November 2016), with a view to providing more specific guidance on the provision of suitable means for the calibration of portable atmosphere testing instruments, approved a unified interpretation of SOLAS regulation XI-1/7, as set out in the annex.

2 Member States are invited to use the annexed unified interpretation as guidance when applying SOLAS regulation XI-1/7 and to bring it to the attention of all parties concerned.

\*\*\*

## ANNEX

### UNIFIED INTERPRETATION OF SOLAS REGULATION XI-1/7

#### **Provision of suitable means for the calibration of portable atmosphere testing instruments**

Compliance with the provision "suitable means shall be provided for the calibration of all such instruments" in SOLAS regulation XI-1/7, as adopted by resolution MSC.380(94), may be achieved by portable atmosphere testing instruments being calibrated on board or ashore in accordance with the manufacturer's instructions.

For the avoidance of any doubt, the above clarification refers to the calibration of portable atmosphere testing instruments, as required by SOLAS regulation XI-1/7, and not to any pre-operational accuracy tests as recommended by the manufacturer.

---