

P2 Rules for piping design, construction and testing

P2.1 Foreword

(1981)
(Rev. 1
1987)(Rev.2, Nov. 2001)

The present requirements are related to piping-systems made of carbon, carbon-manganese, alloy steels or non-ferrous material normally installed on board ships for services considered in Table 1.

These requirements cover the following services:

Air, vapour, gas (excluding liquefied gas cargo and process piping), water, lubricating oil, fuel oil, hydraulic fluid systems for steering gear, toxic gas and liquids, cargo oil and tank cleaning piping and open ended lines such as drains, overflows, vents and boiler escape pipes.

They do not include pipes forming integral part of a boiler.

Hydraulic fluid systems other than those for steering gear shall be specially considered by each individual Classification Society.

Piping systems intended for liquefied gases (cargo and process) are dealt with in UR G3 and W1.

These requirements do not apply to cargo piping systems of ships carrying chemicals in bulk.

P2.2 Classes of pipes

(1974)
(Rev. 1
1975
Rev. 2
1987)
(Rev. 3
May
2000)(Rev.4, Nov. 2001)

For the purpose of testing, the type of joint to be adopted, heat treatment and welding procedure, pipes are subdivided into three classes as indicated in Figure 1 and Table 1.

P2
cont'd

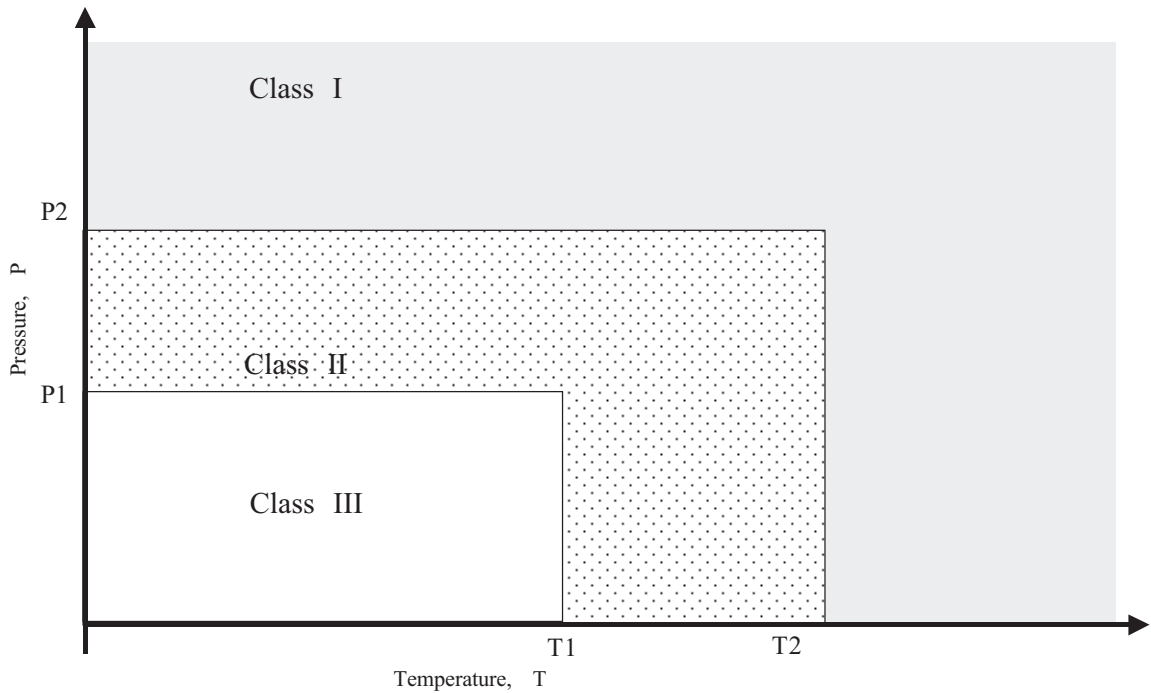

Figure 1

Table 1

Piping System for	Class I $P >$ or $T >$	Class II	Class III $P \leq$ & $T \leq$
Toxic or corrosive media	Without special safeguards	With special safeguards (1,2)	Not applicable
Flammable media heated above flash point or with flash point below 60°C	Without special safeguards	With special safeguards (1)	Not Applicable
Liquefied Gas			
Steam	16 300	Any pressure-temperature combination not belong to Class I or III	7 170
Thermal Oil	16 300		7 150
Fuel Oil			
Lubricating Oil	16 150		7 60
Flammable Hydraulic Oil			
Other Media (5,6)	40 300		16 200

Notes:

- Safeguards for reducing leakage possibility and limiting its consequences :
e.g. pipes led in positions where leakage of internal fluids will not cause a potential hazard or damage to surrounding areas which may include the use of pipe ducts, shielding, screening etc.
- Class II pipes are not to be used for toxic media
- Cargo oil pipes belong to Class III
- P = Design pressure (bar), as defined in P1.2.7 T = Design temperature ($^{\circ}$ C), as defined in P1.2.8
- Including water, air, gases, non-flammable hydraulic oil
- Open ended pipes (drains, overflows, vents, exhaust gas lines, boiler escape pipes) irrespective of T , belong to Class III

P2 cont'd

P2.3 Materials (1974) (Rev. 1,1987)(Rev.2 Nov. 2001)

The materials to be used for the various pipes, valves and fittings are to be suitable for the medium and service for which the piping is intended (see P2.3.1 to P2.3.4)

In the case of especially corrosive media, the materials for the piping system will be considered by the Classification Society in each particular case.

P2.3.1 Steel pipes, valves and other fittings

Pipes belonging to Classes I and II are to be seamless drawn steel pipes or pipes fabricated with a welding procedure, considered by the Society to be equivalent to seamless pipes.

In general, carbon and carbon-manganese steel pipes, valves and other fittings are not to be employed for temperatures above 400°C. Nevertheless, they may be used for higher temperatures if their metallurgical behaviour and time dependent strength (UTS after 100 000 hours) are in accordance with national or international codes or standards and if such valves are guaranteed by the steel manufacturer. Otherwise, special alloy steel pipes, valve and fittings should be employed according to Rules on materials of the Classification Society.

P2.3.2 Copper and copper alloy pipes, valves and fittings

Copper and copper alloy piping shall be of seamless drawn material or other type approved by the Classification Society.

Copper pipes for Classes I and II are to be seamless.

In general., copper and copper alloy piping, valves and fittings shall not be used for media having temperature above the following limits:

.1 Copper and aluminium brass	200°C
.2 Copper nickel	300°C

(see Table 6 of P1).

Special bronze suitable for high temperature services may be accepted in general up to 260°C.

P2.3.3 Nodular cast iron pipes, valves and other fittings

Nodular cast iron of the ferritic type according to the material rules of the Classification Society may be accepted for bilge, ballast and cargo oil piping.

Ferritic nodular cast iron valves and other fittings may be accepted for media having temperatures not exceeding 350°C.

The use of this material for pipes, valves and fittings for other services, in principle Classes II and III, will be subject to special consideration.

Nodular cast iron pipes and valves fitted on the ship's side should have specified properties to the Classification Society's satisfaction, according to the intention of Regulation 22 of the 1966 Convention on Load Lines.

P2.3.4 Ordinary cast iron pipes, valves and fittings

Ordinary cast iron pipes, valves and fittings may be accepted in principle for Class III at the Classification Society's judgement.

Ordinary cast iron piping may be accepted for cargo oil lines within cargo tanks of tankers.

Ordinary cast iron is not to be used for pipes, valves and other fittings handling media having temperature above 220°C and for piping subject to pressure shock, excessive strains and vibrations.



P2
cont'd

Ordinary cast iron may be accepted for pressures up to 16 bar for cargo oil pipelines on weather decks of oil tankers except for manifolds and their valves and fittings connected to cargo handling hoses.

Ordinary cast iron shall not be used for sea valves and pipes fitted on the ship sides, and for valves fitted on the collision bulkhead.

The use of cast iron for other services will be subject to special consideration in each case.

P2.4 Testing of Materials
(1974)

Material for pipes, valves and relative fittings belonging to Classes I and II and for valves and pipes fitted on the ship's side and for valves fitted on the collision bulkhead are to be tested in accordance with applicable Rules of the individual Classification Society.

The individual Classification Society may require internal workshop certificates for pipes, valves and fittings belonging to Class III.



P2
cont'd

P2.5 Welding
(1974)
(Rev. 1
1987)(Corr. Nov. 2001)

P2.5.1 General

The welding joints belonging to Class I or II piping systems shall be effected by approved procedures. Consumables and welders shall meet the requirements of the Classification Society's Rules.

Joint preparations and tolerance shall be appropriate to the welding process, in accordance with the Classification Society's Rules or recognized standards.

Welding shall be done according to applicable requirements and good practice; the weld preparations and the welded joint shall be inspected as may be necessary in the course of fabrication and after completion of the welding heat treatment. For non-destructive tests, see P2.6

The following requirements apply to the fabrication of Classes I and II piping systems operating at ambient or high temperature and made of steel of the types given hereunder:

- .1 carbon and carbon-manganese steels having minimum tensile strength (Rm) 320, 360, 410, 460 and 490 N/mm².
- .2 low alloy carbon-molybdenum, chromium-molybdenum, chromium-molybdenum-vanadium steels having chemical composition 0,3 Mo; 1 Cr - 0,5 Mo; 2,25 Cr - 1 Mo; 0,5 Cr - 0,5 Mo - 0,25V.

At the discretion of the Society, these requirements may be applied also to the Class III piping systems and to repair welding of pipelines.

Refrigerated cargo installations piping systems operating at temperatures lower than -40°C will be given special consideration by each Society.

P2.5.2 Edge preparation for welded joints

Edge preparation is to be in accordance with recognized standards and/or approved drawings.

The preparation of the edges shall be preferably carried out by mechanical means. When flame cutting is used, care should be taken to remove the oxide scales and any notch due to irregular cutting by matching grinding or chipping back to sound metal.

P2.5.3 Alignment and assembling

P2.5.3.1 Unless otherwise agreed by the Society, the tolerances on the alignment of the pipes to be welded are to be as follows:

- .1 Pipes of all diameters and thicknesses welded with permanently fitted backing ring: 0,5 mm.
- .2 Pipes welded without fitted backing ring:
 - .2.1 inside diameter less than 150 mm, thickness up to 6 mm included - 1 mm or $\frac{1}{4}$ whichever is less;
 - .2.2 inside diameter less than 300 mm, thickness up to 9,5 mm included - 1,5 mm or $\frac{1}{4}$ whichever is less;
 - .2.3 inside diameter 300 mm and over, or over thickness 9,5 mm included - 2,0 mm or $\frac{1}{4}$ whichever is less.

NOTE:

For Class III piping systems, the requirements for alignment tolerances may be waived at the discretion of the Society.

P2.5.3.2 Assembling for welding is to be appropriate and within the prescribed tolerances.

Tack welds should be made with an electrode suitable for the base metal; tack welds which form part of the finished weld should be made using approved procedures.

When welding materials requiring preheating, the same preheating should be applied during tack welding. ►

P2.5.4 Preheating

Preheating of the different types of steels will be dependent upon their thickness and chemical composition as indicated in Table 2.

In any case, dryness is to be ensured using, if necessary, suitable preheating.

Table 2 values are based on use of low hydrogen processes; consideration should be given to using higher preheating temperatures when low hydrogen processes are not used.

Table 2

Type of steel	Thickness of thicker part (mm)	Minimum preheating temperature (°C)
C and C/Mn steels	$C + \frac{Mn}{6} \leq 0,40$	≥ 20 (2)
	$C + \frac{Mn}{6} > 0,40$	≥ 20 (2)
0,3 Mo	> 13 (2)	100
1 Cr - 0,5 Mo	< 13	100
	≥ 13	150
2,25 Cr - 1 Mo and 0,5 Cr - 0,5 Mo - 0,25 V (1)	<13	150
	≥ 13	200

NOTES:

- For these materials, preheating may be omitted for thicknesses up to 6 mm if the results of hardness tests carried out on welding procedure qualification are considered acceptable by the Society.
- For welding in ambient temperature below 0°C, the minimum preheating temperature is required independent of the thickness unless specifically approved by the Classification Society.

P2.5.5 Heat-treatment after forming and welding

P2.5.5.1 The heat treatments are not to impair the specified properties of the materials; verifications may be required to this effect as necessary.

The heat treatments are preferably to be carried out in suitable furnaces provided with temperature recording equipment. However, also localized heat treatments on a sufficient portion of the length way of the welded joint, carried out with approved procedures, can be accepted.

P2.5.5.2 Hot forming is to be generally carried out in the temperature range 1000° - 850°C for all grades; however, the temperature may decrease to 750°C during the forming process.

- When the hot forming is carried out within this temperature range, the following generally applies:



P2
cont'd

- .1.1 for C, C-Mn and C-Mo steels, no subsequent heat treatment is required:
 .1.2 for Cr-Mo and C-Mo-V steels, a subsequent stress relieving heat treatment accordance with Table 3 is required.
2. When the hot forming is carried outside the above temperature range, a subsequent new heat treatment in accordance with Table 4 is generally required for all grades.

P2.5.5.3 After cold forming, when $r \leq 4D$ (where r is the mean bending radius and D is the outside diameter of pipe) consideration is to be given to a complete heat treatment in accordance with Table 4; in any case, a stress relieving heat treatment in accordance with Table 3 is required for all grades other than carbon and carbon-manganese steels with R_m 320, 360 and 410.

P2.5.5.4 Stress relieving heat treatment after welding for other than the oxy-acetylene welding process is required as indicated in Table 3 depending on the type of steel and thickness.

The temperature ranges given in the Table are in accordance with common practice. Other values for upper and lower temperature limits may be stipulated by the Society.

The stress relieving heat treatment is to consist in heating the piping slowly and uniformly to a temperature within the range indicated in the Table, soaking at this temperature for a suitable period, in general one hour per 25 mm of thickness with minimum half an hour, cooling slowly and uniformly in the furnace to a temperature not exceeding 400°C and subsequently cooling in a still atmosphere.

In any case, the heat treatment temperature is not to be higher than $t_T - 20^\circ\text{C}$ where t_T is the temperature of the final tempering treatment of the material.

Table 3

Type of steel	Thickness of thicker part (mm)	Stress relief heat treatment temperature (°C)
C and C-Mn	≥ 15 (1) (3)	550 to 620
0,3 Mo	≥ 15 (1)	580 to 640
1 Cr - 0,5 Mo	>8	620 to 680
2,25 Cr - 1 Mo and 0,5 Cr - 0,5 Mo - 0,25 V	any (2)	650 to 720

NOTES:

- When steels with specified Charpy V notch impact properties at low temperature are used, the thickness above which postweld heat treatment shall be applied may be increased by special agreement with the Society
- Heat treatment may be omitted for pipes having thickness ≤ 8 mm, diameter ≤ 100 mm and minimum service temperature 450°C.
- For C and C-Mn steels, stress relieving heat treatment may be omitted up to 30 mm thickness by special agreement with the Society.

P2.5.5.5 Unless otherwise specified, for oxyacetylene welding, the heat treatment indicated in Table 4 depending on the type of steel is required.

The temperature ranges given in the Table are in accordance with common practice. Different values for upper and lower temperature limits may be stipulated by the Society.



P2
cont'd

Table 4

Type of steel	Heat treatment and temperature (°C)
C and C-Mn	Normalizing 880 to 940
0,3 Mo	Normalizing 900 to 940
1 Cr - 0,5 Mo	Normalizing 900 to 960 Tempering 640 to 720
2,25 Cr - 1 Mo	Normalizing 900 to 960 Tempering 650 to 780
0,5 Cr - 0,5 Mo - 0,25 V	Normalizing 930 to 980 Tempering 670 to 720

P2.6 Non destructive testing of welds and acceptance criteria
(1987)

P2.6.1 In general, the welded joints including the inside wherever possible shall be visually examined and non destructive tests will be required depending on the class of pipes and type of joint as hereunder indicated.

- .1 Butt-welded joints - Radiographic examination is to be required as follows:
 - .1.1 pipes of Class I: full radiographic examination when the outside diameter is greater than 75 mm;
 - .1.2 pipes of Class II: at least 10% random radiography when the outside diameter is greater than 100 mm.
More stringent requirements may be applied at the Society's discretion depending on the kind of materials, welding procedure and controls during the fabrication.
An approved ultrasonic testing procedure may be accepted, at the Society's discretion, in lieu of radiographic testing when the conditions are such that a comparable level of weld quality is assured.
- .2 Fillet welds of flange pipe connections are to be examined by the magnetic particle method or by other appropriate non-destructive methods, in case of Class I pipes.
In other cases, magnetic particle examination or equivalent non-destructive testing may be required at the discretion of the Surveyor.
- .3 Ultrasonic examination in addition to the above non-destructive testing may be required in special cases at the Society's discretion.

P2.6.2 Radiographic and ultrasonic examination is to be performed with an appropriate technique by trained operators.

At the request of the Society, complete details of the radiographic or ultrasonic technique is to be submitted for approval.

P2.6.3 Magnetic particle examination is to be performed with suitable equipment and procedures, and with a magnetic flux output sufficient for defect detection. The equipment may be required to be checked against standard samples.

P2.6.4 The welds are to meet the acceptable standard level as required by the individual Society. Unacceptable defects are to be removed and repaired according to the satisfaction of the Society.

P2 cont'd

2.7 Types of connections

(1974)
(Rev. 1
1987)
(Rev. 2
Nov. 2001)

Direct connections of pipe lengths may be made by direct welding, flanges, threaded joints or mechanical joints, and should be to a recognised standard or of a design proven to be suitable for the intended purpose and acceptable to the Classification Society.

The expression "mechanical joints" means devices intended for direct connection of pipe lengths other than by welding, flanges or threaded joints described in 2.7.1, 2.7.2 and 2.7.3 below.

P 2.7.1 Welded connections

Welding and non destructive testing of welds are to be carried out in accordance with P2.5 and P2.6 and requirements of Classification Society.

P 2.7.1.1 Butt welded joints

Butt welded joints shall be of full penetration type generally with or without special provision for a high quality of root side.*

Butt welded joints with special provision for a high quality of root side may be used for piping of any Class, any outside diameter.

Butt welded joints without special provision for a high quality of root side may be used for piping systems of Class II and III irrespective of outside diameter.

P 2.7.1.2 Slip-on sleeve and socket welded joints

Slip-on sleeve and socket welded joints are to have sleeves, sockets and weldments of adequate dimensions conforming to Classification Society Rules or recognized Standard.

Slip-on sleeve and socket welded joints may be used in Class III systems, any outside diameter.

In particular cases, slip-on sleeve and socket welded joints may be allowed by the Classification Society for piping systems of Class I and II having outside diameter ≤ 88.9 mm except for piping systems conveying toxic media or services where fatigue, severe erosion or crevice corrosion is expected to occur.

P 2.7.2 Flange connections

P2.7.2.1 The dimensions and configuration of flanges and bolts are to be chosen in accordance with recognized standards.

Gaskets are to be suitable for the media being conveyed under design pressure and temperature conditions and their dimensions and configuration are to be in accordance with recognised standards.

*) The expression "special provision for a high quality of root side" means that butt welds were accomplished as double welded or by use of a backing ring or inert gas back-up on first pass, or other similar methods accepted by the Classification Society.



P2
cont'd

For non-standard flanges the dimensions of flanges and bolts are to be subject to special consideration.

P2.7.2.2 Examples of flange attachments are shown in Table 5. However, other types of flange attachments may be considered by the Classification Society in each particular case.

Table 5 Examples of flange attachments

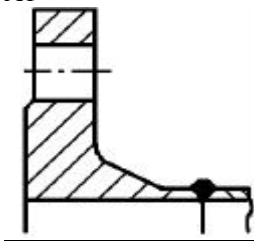
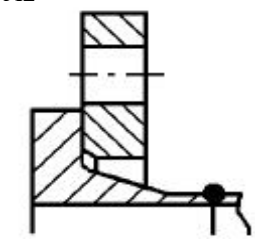
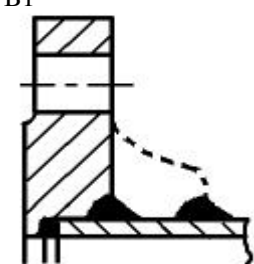
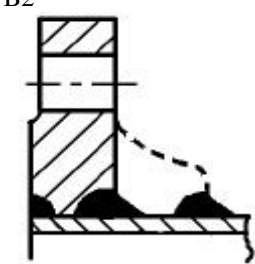
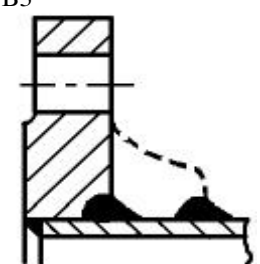
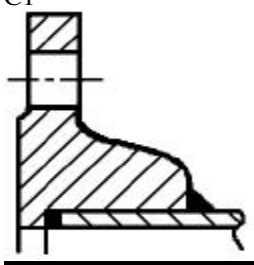
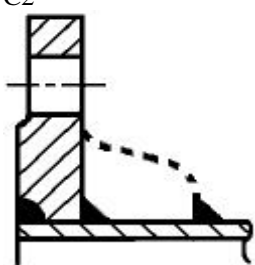
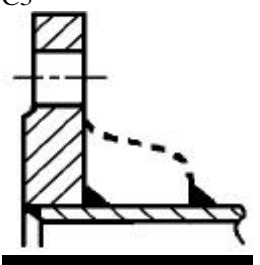
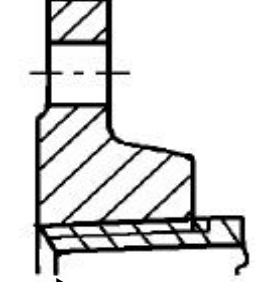
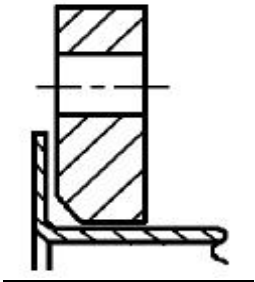
A	A1 	A2 	
B	B1 	B2 	B3 
C	C1 	C2 	C3 
D			
E			

Note: For type D, the pipe and flange are to be screwed with a tapered thread and the diameter of the screw portion of the pipe over the thread is not to be appreciably less than the outside diameter of the unthreaded pipe. For certain types of thread, after the flange has been screwed hard home, the pipe is to be expanded into the flange.



P2

P2.7.2.3 Flange attachments are to be in accordance with national or international standards that are applicable to the piping system and are to recognize the boundary fluids, design pressure and temperature conditions, external or cyclic loading and location.

P 2.7.3 Slip-on threaded joints.

Slip-on threaded joints having pipe threads where pressure-tight joints are made on the threads with parallel or tapered threads, shall comply with requirements of a recognized national or international standard.

Slip-on threaded joints may be used for outside diameters as stated below except for piping systems conveying toxic or flammable media or services where fatigue, severe erosion or crevice corrosion is expected to occur.

Threaded joints in CO₂ systems shall be allowed only inside protected spaces and in CO₂ cylinder rooms.

Threaded joints for direct connectors of pipe lengths with tapered thread are to be allowed for:

- a) Class I, outside diameter not more than 33.7 mm,
- b) Class II and Class III, outside diameter not more than 60.3 mm.

Threaded joints with parallel thread are to be allowed for Class III, outside diameter not more than 60.3 mm.

In particular cases, sizes in excess of those mentioned above may be accepted by the Classification Society if in compliance with a recognized national and/or international standard.



P2.7.4 Mechanical joints (Rev.5, Nov 2003)(Rev.6 May 2006)

Due to the great variations in design and configuration of mechanical joints, no specific recommendation regarding calculation method for theoretical strength calculations is given in these requirements. The Type Approval is to be based on the results of testing of the actual joints.

These requirements are applicable to pipe unions, compression couplings, slip-on joints as shown in Table 6. Similar joints complying with these requirements may be acceptable.

P2.7.4.1 The application and pressure ratings of different mechanical joints are to be approved by the Classification Society. The approval is to be based on the Type Approval procedure in P.2.11. Mechanical joints including pipe unions, compression couplings, slip-on joints and similar joints are to be of approved type for the service conditions and the intended application.

P 2.7.4.2 Where the application of mechanical joints results in reduction in pipe wall thickness due to the use of bite type rings or other structural elements, this is to be taken into account in determining the minimum wall thickness of the pipe to withstand the design pressure.

P2.7.4.3 Construction of mechanical joints is to prevent the possibility of tightness failure affected by pressure pulsation, piping vibration, temperature variation and other similar adverse effects occurring during operation on board.

P2.7.4.4 Material of mechanical joints is to be compatible with the piping material and internal and external media.

P2.7.4.5 Mechanical joints are to be tested where applicable, to a burst pressure of 4 times the design pressure.

For design pressures above 200 bar the required burst pressure will be specially considered by the Classification Society.

P 2.7.4.6 In general, mechanical joints are to be of fire resistant type as required by Table 7.

P 2.7.4.7 Mechanical joints, which in the event of damage could cause fire or flooding, are not to be used in piping sections directly connected to the sea openings or tanks containing flammable fluids.

P 2.7.4.8 The mechanical joints are to be designed to withstand internal and external pressure as applicable and where used in suction lines are to be capable of operating under vacuum.

P 2.7.4.9 The number of mechanical joints in oil systems is to be kept to a minimum. In general, flanged joints conforming to recognised standards are to be used.

P 2.7.4.10 Piping in which a mechanical joint is fitted is to be adequately adjusted, aligned and supported. Supports or hangers are not to be used to force alignment of piping at the point of connection.

P 2.7.4.11 Slip-on joints are not to be used in pipelines in cargo holds, tanks, and other spaces which are not easily accessible, unless approved by the Classification Society. Application of these joints inside tanks may be permitted only for the same media that is in the tanks. Unrestrained Slip-on joints are to be used only in cases where compensation of lateral pipe deformation is necessary. Usage of these joints as the main means of pipe connection is not permitted.

P2.7.4.12 Application of mechanical joints and their acceptable use for each service is indicated in Table 7; dependence upon the Class of piping, pipe dimensions, working pressure and temperature is indicated in Table 8.

In particular cases, sizes in excess of those mentioned above may be accepted by the Classification Society if in compliance with a recognized national and/or international standard.

P2.7.4.13 Mechanical joints are to be tested in accordance with a program approved by the Classification Society, which is to include at least the following:

- .1 leakage test
- .2 vacuum test (where necessary)
- .3 vibration (fatigue) test
- .4 fire endurance test (where necessary)
- .5 burst pressure test
- .6 pressure pulsation test (where necessary)
- .7 assembly test (where necessary)
- .8 pull out test (where necessary)

P2.7.4.14 The installation of mechanical joints is to be in accordance with the manufacturer's assembly instructions. Where special tools and gauges are required for installation of the joints, these are to be supplied by the manufacturer.

The requirements introduced in Revision 5 of UR P2.7.4 (Nov 2003), are to be uniformly implemented by all IACS Societies, in conjunction with UR P2.11 (Nov. 2001), for application to any mechanical pipe joints submitted for approval from 1 January 2007 and to any renewal of type approval of existing design of mechanical pipe joint after 1 January 2007. 

P2
cont'd

Table 6 **Examples of mechanical joints**

Pipe Unions	
Welded and Brazed Types	
Compression Couplings	
Swage Type	
Press Type	
Bite Type	
Flared Type	



P2
cont'd

Slip-on Joints	
Grip Type	
Machine Grooved type	
Slip Type	



Table 7 Application of mechanical joints

The following table indicates systems where the various kinds of joints may be accepted. However, in all cases, acceptance of the joint type is to be subject to approval for the intended application, and subject to conditions of the approval and applicable Rules.

Systems		Kind of connections		
		Pipe Unions	Compression Couplings 6)	Slip-on Joints
Flammable fluids (Flash point $\leq 60^0$)				
1	Cargo oil lines	+	+	+5)
2	Crude oil washing lines	+	+	+5)
3	Vent lines	+	+	+3)
Inert gas				
4	Water seal effluent lines	+	+	+
5	Scrubber effluent lines	+	+	+
6	Main lines	+	+	+2)5)
7	Distributions lines	+	+	+5)
Flammable fluids (Flash point $> 60^0$)				
8	Cargo oil lines	+	+	+5)
9	Fuel oil lines	+	+	+3)2)
10	Lubricating oil lines	+	+	+2)3)
11	Hydraulic oil	+	+	+2)3)
12	Thermal oil	+	+	+2)3)
Sea Water				
13	Bilge lines	+	+	+1)
14	Fire main and water spray	+	+	+3)
15	Foam system	+	+	+3)
16	Sprinkler system	+	+	+3)
17	Ballast system	+	+	+1)
18	Cooling water system	+	+	+1)
19	Tank cleaning services	+	+	+
20	Non-essential systems	+	+	+
Fresh water				
21	Cooling water system	+	+	+1)
22	Condensate return	+	+	+1)
23	Non-essential system	+	+	+
Sanitary/Drains/Scuppers				
24	Deck drains (internal)	+	+	+4)
25	Sanitary drains	+	+	+
26	Scuppers and discharge (overboard)	+	+	-
Sounding/Vent				
27	Water tanks/Dry spaces	+	+	+
28	Oil tanks (f.p.> 60 ⁰ C)	+	+	+2)3)
Miscellaneous				
29	Starting/Control air 1)	+	+	-
30	Service air (non-essential)	+	+	+
31	Brine	+	+	+
32	CO ₂ system 1)	+	+	-
33	Steam	+	+	-

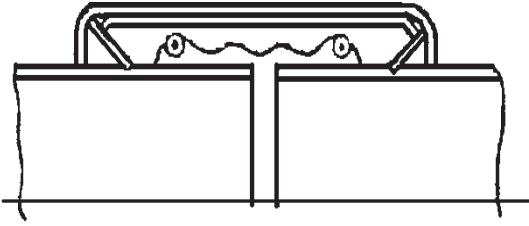
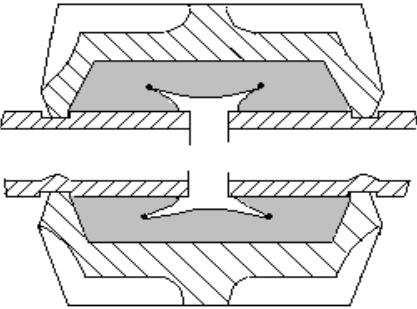
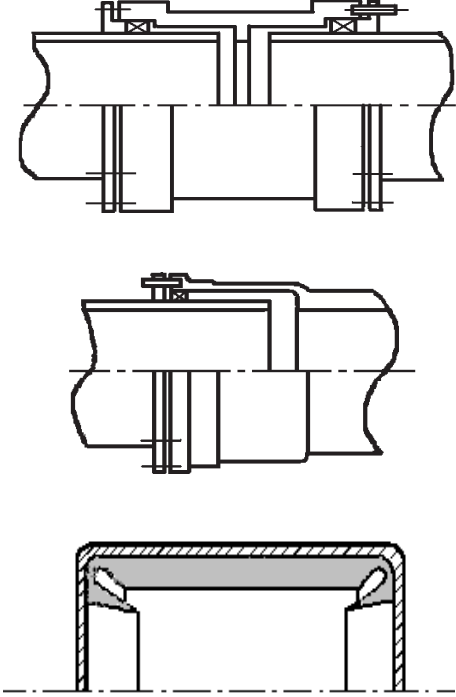
P2

cont'd

Abbreviations

- + Application is allowed
- Application is not allowed

Footnotes:

- 1) Inside machinery spaces of category A - only approved fire resistant types
- 2) Not inside machinery spaces of category A or accommodation spaces. May be accepted in other machinery spaces provided the joints are located in easily visible and accessible positions.
- 3) Approved fire resistant types
- 4) Above free board deck only
- 5) In pump rooms and open decks - only approved fire resistant types
- 6) If Compression Couplings include any components which readily deteriorate in case of fire, they are to be of approved fire resistant type as required for Slip-on joints.

Table 8 Application of mechanical joints depending upon the class of piping

Types of joints	Classes of piping systems		
	Class I	Class II	Class III
Pipe Unions			
Welded and brazed type	+ (OD ≤ 60.3mm)	+(OD≤60.3mm)	+
Compression Couplings			
Swage type	+	+	+
Bite type	+(OD≤60.3mm)	+(OD≤60.3mm)	+
Flared type	+(OD≤60.3mm)	+(OD≤60.3mm)	+
Press type	-	-	+
Slip-on joints			
Machine grooved type	+	+	+
Grip type	-	+	+
Slip type	-	+	+

Abbreviations:

- + Application is allowed
- Application is not allowed



P2
cont'd

P2.8 Hydrostatic tests of piping

(1974)
(Rev. 1
1987)(Corr. Nov. 2001)

P2.8.1 All Classes I and II pipes and integral fittings and, in all cases, all steam pipes, feed pipes, compresses air pipes and fuel oil pipes having a design pressure greater than 3,5 bar and relative integral fittings, after completion of manufacture but before insulation and coating, if any, shall be subject to a hydrostatic test in the presence of the Surveyor at the following value of pressure:

$$P_H = 1,5P$$

where P_H = test pressure (bar)
 P = design pressure (bar) as defined in P1.2.7.

For steel pipes and integral fittings for temperatures above 300°C, the test pressure is to be determined by the following formula but it is not necessary that it exceeds 2P:

$$P_H = 1,5P \frac{K_{100}}{K_T}$$

where K_{100} = permissible stress at 100°C.
 K_T = permissible stress at the design temperature.

The value of the test pressure may be reduced, with the approval of the Classification Society, to 1,5 P in order to avoid excessive stress in way of bends, T-pieces, etc.

In no case is the membrane stress to exceed 90 percent of the yield stress at the testing temperature.

P2.8.2 When, for technical reasons, it is not possible to carry out complete hydrotesting before assembly on board, for all sections of piping, proposals are to be submitted for approval to the Classification Society for testing the closing lengths of piping, particularly in respect to the closing seams.

P2.8.3 When the hydrostatic test of piping is carried out on board, these tests may be carried out in conjunction with the test required under P2.9.

P2.8.4 Pressure testing of small bore pipes (less than about 15 mm) may be waived at the discretion of the Classification Society depending on the application.



P2
cont'd

P2.9 Pressure tests of piping after assembly on board
(1974)
(Rev. 1
1975
Rev. 2
1987)

After assembly on board, the following tightness tests are to be carried out in the presence of the Surveyor.

In general, all the piping systems covered by these requirements are to be checked for leakage under operational conditions and, if necessary, using special techniques other than hydrostatic testing. In particular, heating coils in tanks and liquid or gas fuel lines are to be tested to not less than 1,5 P but in no case less than 4 bar.



P2.10 Hydrostatic tests of valves and fittings
(1975)
(Rev. 1
1987)(Rev.2. Nov. 2001)

Valves and fittings non-integral with the piping system, intended for Classes I and II, are to be tested in accordance with recognized standards, but to not less than 1,5 times the design pressure.

Valves and cocks intended to be fitted on the ship side below the load waterline are to be tested by hydraulic pressure not less than 5 bar.



P2.11 Type Approval of Mechanical Joints
(Nov. 2001)(Rev.1 May 2006)(Rev.2 Nov 2006)(Corr.1 Apr 2007)

P2.11.1 General

This specification describes the type testing condition for type approval of mechanical joints intended for use in marine piping systems. Conditions outlined in these requirements are to be fulfilled before Type Approval Certificates are issued.

Individual Societies may specify more severe testing conditions and additional tests if considered necessary to ensure the intended reliability and also accept alternative testing in accordance with national or international standards where applicable to the intended use and application.

P2.11.2 Scope

This specification is applicable to mechanical joints defined in UR P 2.7.4 including compression couplings and slip-on joints of different types for marine use.

The requirements of UR P2.11 (Nov 2001) are to be uniformly implemented by all IACS Societies for application to any mechanical pipe joints submitted for approval from 1 January 2007 and to any renewal of type approval of existing design of mechanical pipe joint after 1 January 2007.



P2.11.3 Documentation

Following documents and information are to be submitted by Manufacturer for assessment and/or approval:

- .1 product quality assurance system implemented;
- .2 complete description of the product;
- .3 typical sectional drawings with all dimensions necessary for evaluation of joint design;
- .4 complete specification of materials used for all components of the assembly;
- .5 proposed test procedure as required in P2.11.5 and corresponding test reports or other previous relevant tests;
- .6 initial information:
 - maximum design pressures (pressure and vacuum);
 - maximum and minimum design temperatures;
 - conveyed media;
 - intended services;
 - maximum axial, lateral and angular deviation, allowed by manufacturer;
 - installation details.

P2.11.4 Materials

The materials used for mechanical joints are to comply with the requirements of P2.7.4.4.

The manufacturer has to submit evidence to substantiate that all components are adequately resistant to working the media at design pressure and temperature specified.

P2.11.5 Testing, procedures and requirements

The aim of tests is to demonstrate ability of the pipe joints to operate satisfactory under intended service conditions. The scope and type of tests to be conducted e.g. applicable tests, sequence of testing, and the number of specimen, is subject to approval and will depend on joint design and its intended service in accordance with the requirements of this UR.

Unless otherwise specified, the water or oil as test fluid is to be used.

P2.11.5.1 Test program

Testing requirements for mechanical joints are to be as indicated in Table 9.

P2
cont'd

Table 9

Tests		Types of mechanical joints			Notes and references
		Compression couplings and pipes unions	Slip-on Joints		
			Grip type & Machine grooved type	Slip type	
1	Tightness test	+	+	+	P2.11.5.5.1
2	Vibration (fatigue) test	+	+	-	P2.11.5.5.2
3	Pressure pulsation test, 1)	+	+	-	P2.11.5.5.3
4	Burst pressure test	+	+	+	P2.11.5.5.4
5	Pull-out test	+	+	-	P2.11.5.5.5
6	Fire endurance test	+	+	+	P2.11.5.5.6 If required by UR P2.7.4.6
7	Vacuum test	+ ³⁾	+	+	P2.11.5.5.7 for suction lines only
8	Repeated assembly test	+ ²⁾	+	-	P2.11.5.5.8

Abbreviations: + test is required
- test is not required

Note: 1) for use in those systems where pressure pulsation other than water hammer is expected.
2) except press type.
3) except joints with metal-to-metal tightening surfaces.



P2.11.5.2 Selection of Test Specimen

Test specimens are to be selected from production line or at random from stock.

Where there are various sizes from type of joints requiring approval, minimum of three separate sizes representative of the range, from each type of joints are to be subject to the tests listed in Table 9.

P2.11.5.3 Mechanical Joint Assembly

Assembly of mechanical joints should consist of components selected in accordance with P2.11.5.2 and the pipe sizes appropriate to the design of the joints.

Where pipe material would effect the performance of mechanical joints, the selection of joints for testing is to take the pipe material into consideration.

Where not specified, the length of pipes to be connected by means of the joint to be tested is to be at least five times the pipe diameter. Before assembling the joint, conformity of components to the design requirements, is to be verified. In all cases the assembly of the joint shall be carried out only according to the manufacturer's instructions. No adjustment operations on the joint assembly, other than that specified by the manufacturer, are permitted during the test.

P2.11.5.4 Test Results Acceptance Criteria

Where a mechanical joint assembly does not pass all or any part of the tests in Table 9, two assemblies of the same size and type that failed are to be tested and only those tests which mechanical joint assembly failed in the first instance, are to be repeated. In the event where one of the assemblies fails the second test, that size and type of assembly is to be considered unacceptable.

The methods and results of each test are to be recorded and reproduced as and when required.

P2.11.5.5 Methods of tests**.1 Tightness test**

In order to ensure correct assembly and tightness of the joints, all mechanical joints are to be subjected to a tightness test, as follows.

- a) Mechanical joint assembly test specimen is to be connected to the pipe or tubing in accordance with the requirements of P2.11.5.3 and the manufacturers instructions, filled with test fluid and de-aerated.

Mechanical joints assemblies intended for use in rigid connections of pipe lengths, are not to be longitudinally restrained.

Pressure inside the joint assembly is to be slowly increased to 1.5 times of design pressure. This test pressure is to be retained for a minimum period of 5 minutes.

In the event where there is a drop in pressure or there is visual indication of leakage, the test (including fire test) shall be repeated for two test pieces.

If during the repeat test one test piece fails, the testing is regarded as having failed.

Other alternative tightness test procedure, such as pneumatic test, may be accepted. ►

P2
cont'd

~~For services other than flammable fluids, leakage rate is not to be more than 0.2l/min.~~

- b) For compression couplings a static gas pressure test is to be carried out to demonstrate the integrity of the mechanical joints assembly for tightness under the influence of gaseous media. The pressure is to be raised to maximum pressure or 70 bar whichever is less.
- c) Where the tightness test is carried out using gaseous media as permitted in (a) above, then the static pressure test mentioned in (b) above need not be carried out.

.2 Vibration (fatigue) test

In order to establish the capability of the mechanical joint assembly to withstand fatigue, which is likely to occur due to vibrations under service conditions, mechanical joints assembly is to be subject to the following vibration test.

Conclusions of the vibration tests should show no leakage or damage, which could subsequently lead to a failure.

a) Testing of compression couplings and pipe unions

Compression couplings, pipe unions or other similar joints intended for use in rigid connections of pipe are to be tested in accordance with this method described as follows. Rigid connections are joints, connecting pipe length without free angular or axial movement.

Two lengths of pipe is to be connected by means of the joint to be tested. One end of the pipe is to be rigidly fixed while the other end is to be fitted to the vibration rig. The test rig and the joint assembly specimen being tested is to be arranged as shown in Fig.1.

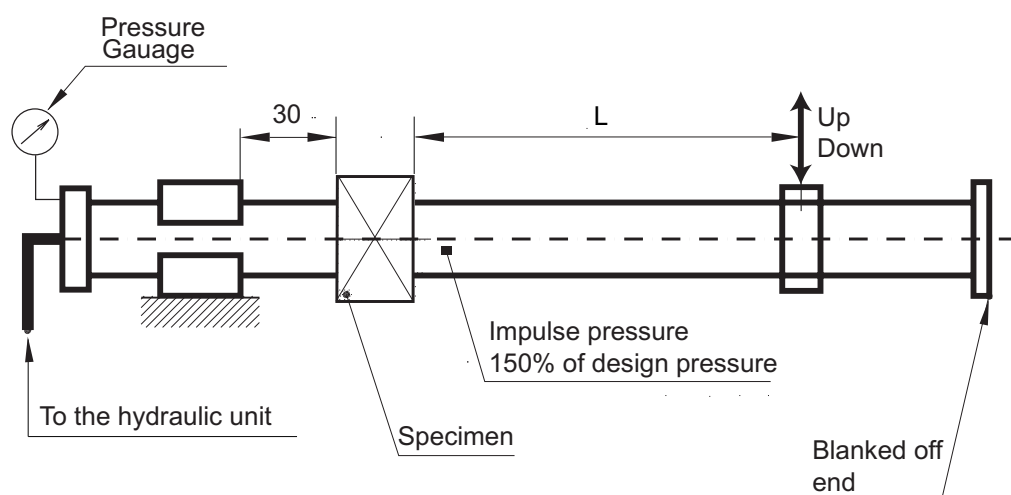

Fig. 1

The joint assembly is to be filled with test fluid, de-aerated and pressurised to the design pressure of the joint. ►

P2 cont'd

Pressure during the test is to be monitored. In the event of drop in the pressure and visual signs of leakage the test is to be repeated as described in P2.11.5.4.

Visual examination of the joint assembly is to be carried out for signs of damage which may eventually lead to joint leakage.

Re-tightening may be accepted once during the first 1000 cycles.

Vibration amplitude is to be within 5% of the value calculated from the following formula:

$$A = \frac{2 \times S \times L^2}{3 \times E \times D}$$

where:

A - single amplitude, mm

L - length of the pipe, mm

S - allowable bending stress in N/mm² based on 0.25 of the yield stress

E - modulus of elasticity of tube material (for mild steel, E = 210 kN/mm²)

D - outside diameter of tube, mm.

Test specimen is to withstand not less than 10⁷ cycles with frequency 20 - 50 Hz without leakage or damage.

b) Grip type and Machine grooved type joints

Grip type joints and other similar joints containing elastic elements are to be tested in accordance with the following method.

A test rig of cantilever type used for testing fatigue strength of components may be used. The test specimen being tested is to be arranged in the test rig as shown in Fig. 2.

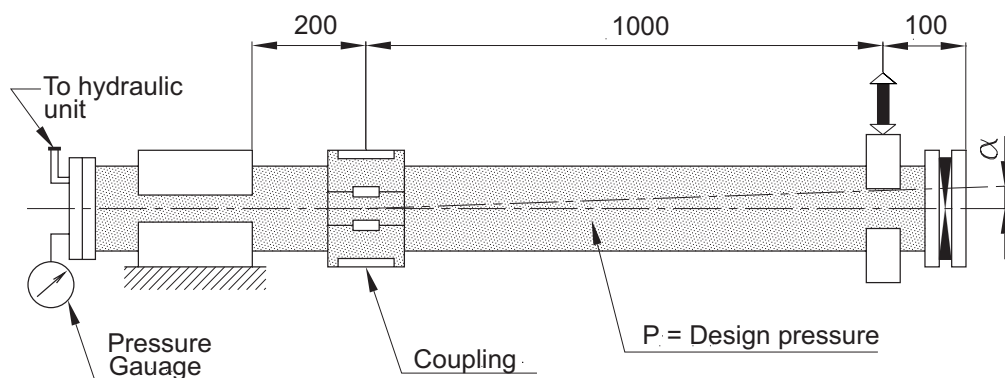

Fig. 2

P2
cont'd

Two lengths of pipes are to be connected by means of joint assembly specimen to be tested. One end of the pipe is to be rigidly fixed while the other end is to be fitted to the vibrating element on the rig. The length of pipe connected to the fixed end should be kept as short as possible and in no case exceeds 200 mm.

Mechanical joint assemblies are not to be longitudinally restrained.

The assembly is to be filled with test fluid, de-aerated and pressurized to the design pressure of the joint. Preliminary angle of deflection of pipe axis is to be equal to the maximum angle of deflection, recommended by the manufacturer. The amplitude is to be measured at 1m distance from the center line of the joint assembly at free pipe end connected to the rotating element of the rig. (See Fig. 2)

Parameters of testing are to be as indicated below and to be carried out on the same assembly:

Number of cycles	Amplitude, mm	Frequency, Hz
$3 \cdot 10^6$	± 0.06	100
$3 \cdot 10^6$	± 0.5	45
$3 \cdot 10^6$	± 1.5	10

Pressure during the test is to be monitored. In the event of a drop in the pressure and visual signs of leakage the test is to be repeated as described in P2.11.5.4. Visual examination of the joint assembly is to be carried out for signs of damage which may eventually cause leakage.

.3 Pressure pulsation test

In order to determine capability of mechanical joint assembly to withstand pressure pulsation likely to occur during working conditions, joint assemblies intended for use in rigid connections of pipe lengths, are to be tested in accordance with the following method.

The mechanical joint test specimen for carrying out this test may be the same as that used in the test in P2.11.5.5.1 (a) provided it passed that test.

The vibration test in P2.11.5.5.2 and the pressure pulsation test are to be carried out simultaneously for compression couplings and pipe unions.

The mechanical joint test specimen is to be connected to a pressure source capable of generating pressure pulses of magnitude as shown in Fig 3.



P2

cont'd

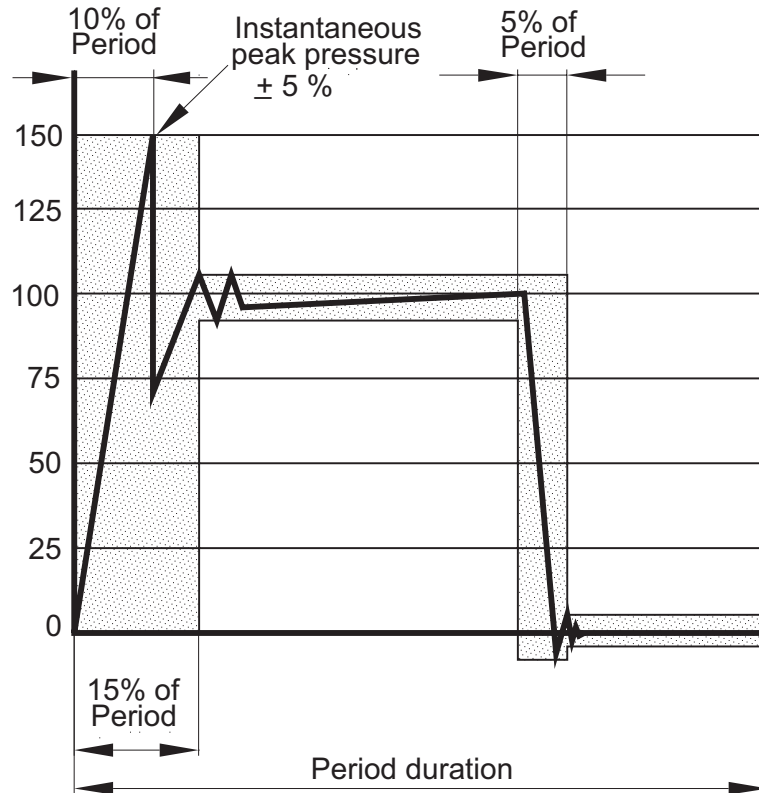

Fig. 3 Impulse pressure diagram

Impulse pressure is to be raised from 0 to 1.5 times the design pressure of the joint with a frequency equal to 30-100 cycles per minute. The number of cycles is not to be less than 5×10^5 .

The mechanical joint is to be examined visually for sign of leakage or damage during the test.

.4 Burst pressure test

In order to determine the capability of the mechanical joint assembly to withstand a pressure as stated by UR P. 2.7.4.5, the following burst test is to be carried out.

Mechanical joint test specimen is to be connected to the pipe or tubing in accordance with the requirements of P2.11.5.3, filled with test fluid, de-aerated and pressurized to test pressure with an increasing rate of 10% per minute of test pressure. The mechanical joint assembly intended for use in rigid connections of pipe lengths is not to be longitudinally restrained.

P2 cont'd

Duration of this test is not to be less than 5 minutes at the maximum pressure. This pressure value will be annotated.

Where consider convenient, the mechanical joint test specimen used in tightness test in P2.11.5.5.1, same specimen may be used for the burst test provided it passed the tightness test.

The specimen may have small deformation whilst under test pressure, but no leakage or visible cracks are permitted.

.5 Pull-out test

In order to determine ability of a mechanical joint assembly to withstand axial load likely to be encountered in service without the connecting pipe from becoming detached, following pull-out test is to be carried out.

Pipe length of suitable size is to be fitted to each end of the mechanical joints assembly test specimen. The test specimen is to be pressurized to design pressure such that the axial loads imposed are of a value calculated by the following formula:

$$L = \frac{\pi}{4} \cdot D^2 \cdot p$$

where: D = pipe outside diameter, mm

p = design pressure, N/mm²

L = applied axial load, N

This axial load is to be maintained for a period of 5 minutes.

During the test, pressure is to be monitored and relative movement between the joint assembly and the pipe measured.

The mechanical joint assembly is to be visually examined for drop in pressure and signs of leakage or damage.

There are to be no movement between mechanical joint assembly and the connecting pipes.

.6 Fire endurance test

In order to establish capability of the mechanical joints to withstand effects of fire which may be encountered in service, mechanical joints are to be subjected to a fire endurance test. The fire endurance test is to be conducted on the selected test specimens as per the following standards.



P2
cont'd

- (a) ISO 19921: 2005(E): Ships and marine technology – Fire resistance of metallic pipe components with resilient and elastomeric seals – Test methods
- (b) ISO 19922: 2005(E): Ships and marine technology – Fire resistance of metallic pipe components with resilient and elastomeric seals – Requirements imposed on the test bench.

Clarifications to the standard requirements:

1. If the fire test is conducted with circulating water at a pressure different from the design pressure of the joint (however of at least 5 bar) the subsequent pressure test is to be carried out to twice the design pressure.
2. A selection of representative nominal bores may be tested in order to evaluate the fire resistance of a series or range of mechanical joints of the same design. When a mechanical joint of a given nominal bore (D_n) is so tested then other mechanical joints falling in the range D_n to $2xD_n$ (both inclusive) are considered accepted.

.7 Vacuum test

In order to establish capability of mechanical joint assembly to withstand internal pressures below atmosphere, similar to the conditions likely to be encountered under service conditions, following vacuum test is to be carried out.

Mechanical joint assembly is to be connected to a vacuum pump and subjected to a pressure 170 mbar absolute. Once this pressure is stabilized the mechanical joint assembly test specimen under test are to be isolated from the vacuum pump and this pressure is to be retained for a period of 5 minutes.

Pressure is to be monitored during the test.

No internal pressure rise is permitted.

.8 Repeated assembly test

Mechanical joint test specimen are to be dismantled and reassembled 10 times in accordance with manufacturers instructions and then subjected to a tightness test as defined in P2.11.5.5.1.



P 2.12 Flexible Hoses
(Jan.2005)**2.12.1 Definition**

2.12.1.1 Flexible hose assembly – short length of metallic or non-metallic hose normally with prefabricated end fittings ready for installation.

2.12.2 Scope

2.12.2.1 The requirements 2.12.3 to 2.12.6 apply to flexible hoses of metallic or non-metallic material intended for a permanent connection between a fixed piping system and items of machinery. The requirements may also be applied to temporary connected flexible hoses or hoses of portable equipment.

2.12.2.2 Flexible hose assemblies as defined in 2.12.1.1 may be accepted for use in oil fuel, lubricating, hydraulic and thermal oil systems, fresh water and sea water cooling systems, compressed air systems, bilge and ballast systems, and Class III steam systems where they comply with 2.12.3 to 2.12.6. Flexible hoses in high pressure fuel oil injection systems are not to be accepted.

2.12.2.3 These requirements for flexible hose assemblies are not applicable to hoses intended to be used in fixed fire extinguishing systems.

2.12.3 Design and construction

2.12.3.1 Flexible hoses are to be designed and constructed in accordance with recognised National or International standards acceptable to the Classification Society. Flexible hoses constructed of rubber or plastics materials and intended for use in bilge, ballast, compressed air, oil fuel, lubricating, hydraulic and thermal oil systems are to incorporate a single or double closely woven integral wire braid or other suitable material reinforcement. Where rubber or plastics materials hoses are to be used in oil supply lines to burners, the hoses are to have external wire braid protection in addition to the integral reinforcement. Flexible hoses for use in steam systems are to be of metallic construction.

2.12.3.2 Flexible hoses are to be complete with approved end fittings in accordance with manufacturer's specification. The end connections that do not have a flange are to comply with P2.7.4 as applicable and each type of hose/fitting combination is to be subject to prototype testing to the same standard as that required by the hose with particular reference to pressure and impulse tests.

2.12.3.3 The use of hose clamps and similar types of end attachments is not acceptable for flexible hoses in piping systems for steam, flammable media, starting air systems or for sea water systems where failure may result in flooding. In other piping systems, the use of hose clamps may be accepted where the working pressure is less than 5 bar and provided there are double clamps at each end connection.

2.12.3.4 Flexible hose assemblies intended for installation in piping systems where pressure pulses and/or high levels of vibration are expected to occur in service, are to be designed for the maximum expected impulse peak pressure and forces due to vibration. The tests required by 2.12.5 are to take into consideration the maximum

anticipated in-service pressures, vibration frequencies and forces due to installation.

2.12.3.5 Flexible hose assemblies constructed of non-metallic materials intended for installation in piping systems for flammable media and sea water systems where failure may result in flooding, are to be of fire-resistant type. Fire resistance is to be demonstrated by testing to ISO 15540 and ISO 15541.

2.12.3.6 Flexible hose assemblies are to be selected for the intended location and application taking into consideration ambient conditions, compatibility with fluids under working pressure and temperature conditions consistent with the manufacturer's instructions and any requirements of the Classification Society.

2.12.4 Installation

2.12.4.1 In general, flexible hoses are to be limited to a length necessary to provide for relative movement between fixed and flexibly mounted items of machinery/equipment or systems.

2.12.4.2 Flexible hose assemblies are not to be installed where they may be subjected to torsion deformation (twisting) under normal operating conditions.

2.12.4.3 The number of flexible hoses, in piping systems mentioned in 2.12.2.2 is to be kept to minimum and to be limited for the purpose stated in 2.12.2.1.

2.12.4.4 Where flexible hoses are intended to be used in piping systems conveying flammable fluids that are in close proximity of heated surfaces the risk of ignition due to failure of the hose assembly and subsequent release of fluids is to be mitigated as far as practicable by the use of screens or other similar protection to the satisfaction of the Classification Society.

2.12.4.5 Flexible hoses are to be installed in clearly visible and readily accessible locations.

2.12.4.6 The installation of flexible hose assemblies is to be in accordance with the manufacturer's instructions and use limitations with particular attention to the following:

- Orientation
- End connection support (where necessary)
- Avoidance of hose contact that could cause rubbing and abrasion
- Minimum bend radii

2.12.5 Tests

2.12.5.1 Acceptance of flexible hose assemblies is subject to satisfactory prototype testing. Prototype test programmes for flexible hose assemblies are to be submitted by the manufacturer and are to be sufficiently detailed to demonstrate performance in accordance with the specified standards.

2.12.5.2 The tests are, as applicable, to be carried out on different nominal diameters of hose type complete with end fittings for pressure, burst, impulse

P2
cont'd

resistance and fire resistance in accordance with the requirements of the relevant standard. The following standards are to be used as applicable.

- ISO 6802 – Rubber and plastics hoses and hose assemblies – Hydraulic pressure impulse test without flexing.
- ISO 6803 - Rubber and plastics hoses and hose assemblies – Hydraulic pressure impulse test with flexing.
- ISO 15540 – Ships and marine technology – Fire resistance of hose assemblies – Test methods.
- ISO 15541 - Ships and marine technology – Fire resistance of hose assemblies – Requirements for test bench.
- ISO 10380 – Pipework – Corrugated metal hoses and hose assemblies.
Other standards may be accepted where agreed by the classification society.

2.12.5.3 All flexible hose assemblies are to be satisfactorily prototype burst tested to an international standard* to demonstrate they are able to withstand a pressure not less than four times its design pressure without indication of failure or leakage.

Note: * The international standards, e.g. EN or SAE for burst testing of non-metallic hoses, require the pressure to be increased until burst without any holding period at 4 x MWP.

2.12.6 Marking

2.12.6.1 Flexible hoses are to be permanently marked by the manufacturer with the following details

- Hose manufacturer's name or trademark.
- Date of manufacture (month/year).
- Designation type reference.
- Nominal diameter.
- Pressure rating
- Temperature rating.

Where a flexible hose assembly is made up of items from different manufacturers, the components are to be clearly identified and traceable to evidence of prototype testing.

END