

SC94 Mechanical, hydraulic and electrical independency and failure detection and response of Electric steering control systems for steering gears

(1994)
(Rev.1
Feb 2010)

(Chapter II-1, Regulation 29)

1. Scope

The interpretation applies to electric/electronic steering gear control systems, as defined in SOLAS regulation II-1, 3/1, for the main and auxiliary steering gear, operable from the navigation bridge, for which SOLAS stipulates two steering gear control systems independent of each other- (SOLAS II-1, Reg. 29/6.1, 29/7.2, 29/7.3, Reg. 29/15 and Reg. 29/16).

SOLAS II-1, Reg. 29/6.1 reads:

“Where the main steering gear comprises two or more identical power units, an auxiliary steering gear need not be fitted, provided that:

- .1 in a passenger ship, the main steering gear is capable of operating the rudder as required by paragraph 3.2 while any one of the power units is out of operation;
- .2 in a cargo ship, the main steering gear is capable of operating the rudder as required by paragraph 3.2 while operating with all power units;
- .3 the main steering gear is so arranged that after a single failure in its piping system or in one of the power units the defect can be isolated so that steering capability can be maintained or speedily regained.”

SOLAS II-1, Regs. 29/7.2 and 7.3 read:

“7 Steering gear control shall be provided:

- .2 where the main steering gear is arranged in accordance with paragraph 6, by two independent control systems, both operable from the navigation bridge. This does not require duplication of the steering wheel or steering lever. Where the control system consists of a hydraulic telemotor, a second independent system need not be fitted, except in a tanker, chemical tanker or gas carrier of 10,000 gross tonnage and upwards;
- .3 for the auxiliary steering gear, in the steering gear compartment and, if power-operated, it shall also be operable from the navigation bridge and shall be independent of the control system for the main steering gear.”

Note:

1. Amendments introduced in Rev.1 are to be uniformly implemented by IACS Societies for ships contracted for construction on or after 1 July 2011.
2. The “contracted for construction” date means the date on which the contract to build the vessel is signed between the prospective owner and the shipbuilder. For further details regarding the date of “contract for construction”, refer to IACS Procedural Requirement (PR) No. 29.

SC94

(cont)

SOLAS II-1, Regs. 29/15 and 16 read:

“15 In every tanker, chemical tanker or gas carrier of 10,000 gross tonnage and upwards and in every other ship of 70,000 gross tonnage and upwards, the main steering gear shall comprise two or more identical power units complying with the provisions of paragraph 6.

16 Every tanker, chemical tanker or gas carrier of 10,000 gross tonnage and upwards shall, subject to paragraph 17, comply with the following:

- .1 the main steering gear shall be so arranged that in the event of loss of steering capability due to a single failure in any part of one of the power actuating systems of the main steering gear, excluding the tiller, quadrant or components serving the same purpose, or seizure of the rudder actuators, steering capability shall be regained in not more than 45 s after the loss of one power actuating system;
- .2 the main steering gear shall comprise either:
 - .2.1 two independent and separate power actuating systems, each capable of meeting the requirements of paragraph 3.2; or
 - .2.2 at least two identical power actuating systems which, acting simultaneously in normal operation, shall be capable of meeting the requirements of paragraph 3.2. Where necessary to comply with this requirement, interconnection of hydraulic power actuating systems shall be provided. Loss of hydraulic fluid from one system shall be capable of being detected and the defective system automatically isolated so that the other actuating system or systems shall remain fully operational;
- .3 steering gears other than of the hydraulic type shall achieve equivalent standards.”

Following requirements of:

- SOLAS Chapt. II-1, Reg. 3/1, 3/3, 3/13 and Reg. 29, ~~steering gear,~~
- IEC Pub. 60092 - 204 Electric and electrohydraulic steering gear (1987)

have been considered, as far as containing requirements for the independency of the control systems.

2. Basic Requirements

Two independent steering gear control systems shall be provided and shall be so arranged that a mechanical or electrical failure in one of them will not render the other one inoperative.

The term “*Steering gear control system*” as defined in SOLAS Part A, Regulation 3/1 (UR M42 Appendix item 1) shall be understood as “*Steering control system*” covering “*the equipment required to control the steering gear power actuating system*”.

3. Supply

~~Each electrical steering gear control system shall be served by its own separate circuit supplied from the steering gear power circuit from a point within the steering gear compartment, or directly from switchboard busbars (main and emergency switchboard) supplying that steering gear power circuit at a point on the switchboard adjacent to the supply to the steering gear power circuit. The power supply systems are to be protected selectively.~~

SC94

(cont)

4. Installation

~~Cables for duplicated steering gear control systems and their associated components shall be separated as far as practicable. The corresponding cables shall follow different routes which will be separated both vertically and horizontally, as far as practicable, throughout their entire length.~~

53. Separation of Control Systems and Components**53.1 General**

Wires, terminals and the components for duplicated steering gear control systems installed in units, control boxes, switchboards or bridge consoles shall be separated as far as practicable. Where physical separation is not practicable, separation may be achieved by means of a fire retardant plate.

53.2 Steering wheel or steering lever

All electric components of the steering gear control systems shall be duplicated. This does not require duplication of the steering wheel or steering lever.

53.3 Steering mode selector switch

If a joint steering mode selector switch (uniaxial switch) is employed for both steering gear control systems, the connections for the circuits of the control systems ~~are to~~ shall be divided accordingly and separated from each other by an isolating plate or by air gap.

53.4 Follow-up amplifier

In the case of double follow-up control (see Annex, example 2), the amplifiers ~~have to~~ shall be designed and fed so as to be electrically and mechanically separated. In the case of non-follow-up control and follow-up control, it ~~will have to~~ shall be ensured that the follow-up amplifiers are ~~is~~ protected selectively (see Annex, example 3).

53.5 Additional control systems

Control circuits for additional control systems, e.g. steering lever or autopilot shall ~~have to~~ be designed for all - pole disconnection (see Annex, examples 1, 2 and 3).

53.6 Feed-back units and limit switches

The feed-back units and limit switches, if any, for the steering gear control systems shall ~~are to~~ be separated electrically and mechanically connected to the rudder stock or actuator separately.

53.7 Actuators Hydraulic control components

~~Actuators~~ Hydraulic system components in the power actuating or hydraulic servo systems controlling the power systems of the steering gear, (e.g. solenoid valves, magnetic valves,) are to be considered as part of the steering gear control system and shall be duplicated and separated.

Hydraulic system components in the steering gear control system that are part of a power unit may be regarded as being duplicated and separated when there are two or more separate power units provided and the piping to each power unit can be isolated.

SC94

(cont)

4. Failure Detection and Response of Control Systems**4.1 Failure detection**

4.1.1 The most probable failures that may cause reduced or erroneous system performance shall be detected, and shall consider at least the following:

- i. Power supply failure
- ii. Loop failures in closed loop systems, both command and feedback loops (normally short circuit, broken connections and earth faults)
- iii. If programmable electronic system are used:
 - 1. data communication errors
 - 2. computer hardware and software failures

Also refer to UR E22 - system category III

- iv. Hydraulic locking considering order given by steering wheel or lever

All failures detected shall initiate an audible and visual alarm on the navigation bridge. Hydraulic locking shall always be warned individually as required in UR M42.12 unless system design makes manual action unnecessary.

Guidance note:

"Hydraulic locking" includes all situations where two hydraulic systems (usually identical) oppose each other in such a way that it may lead to loss of steering. It can either be caused by pressure in the two hydraulic systems working against each other or by hydraulic "by-pass" meaning that the systems puncture each other and cause pressure drop on both sides or make it impossible to build up pressure.

4.1.2 Alternatively to 4.1.1.ii and iii, depending on the rudder characteristic, critical deviations between rudder order and response shall be indicated visually and audibly as steering failure alarm on the navigating bridge.

The following parameters shall be monitored:

- Direction: Actual rudder position follows the set value.
- Delay: Rudder's actual position reaches set position within acceptable time limits.
- Accuracy: The end actual position shall correspond to the set value within the design offset tolerances.

4.2 System response upon failure

The most probable failures, e.g. loss of power or loop failure, shall result in the least critical of any new possible conditions.

65. Annex

Reference should be made to examples 1, 2 and 3, which can be regarded as basic design.

SC94
(cont)

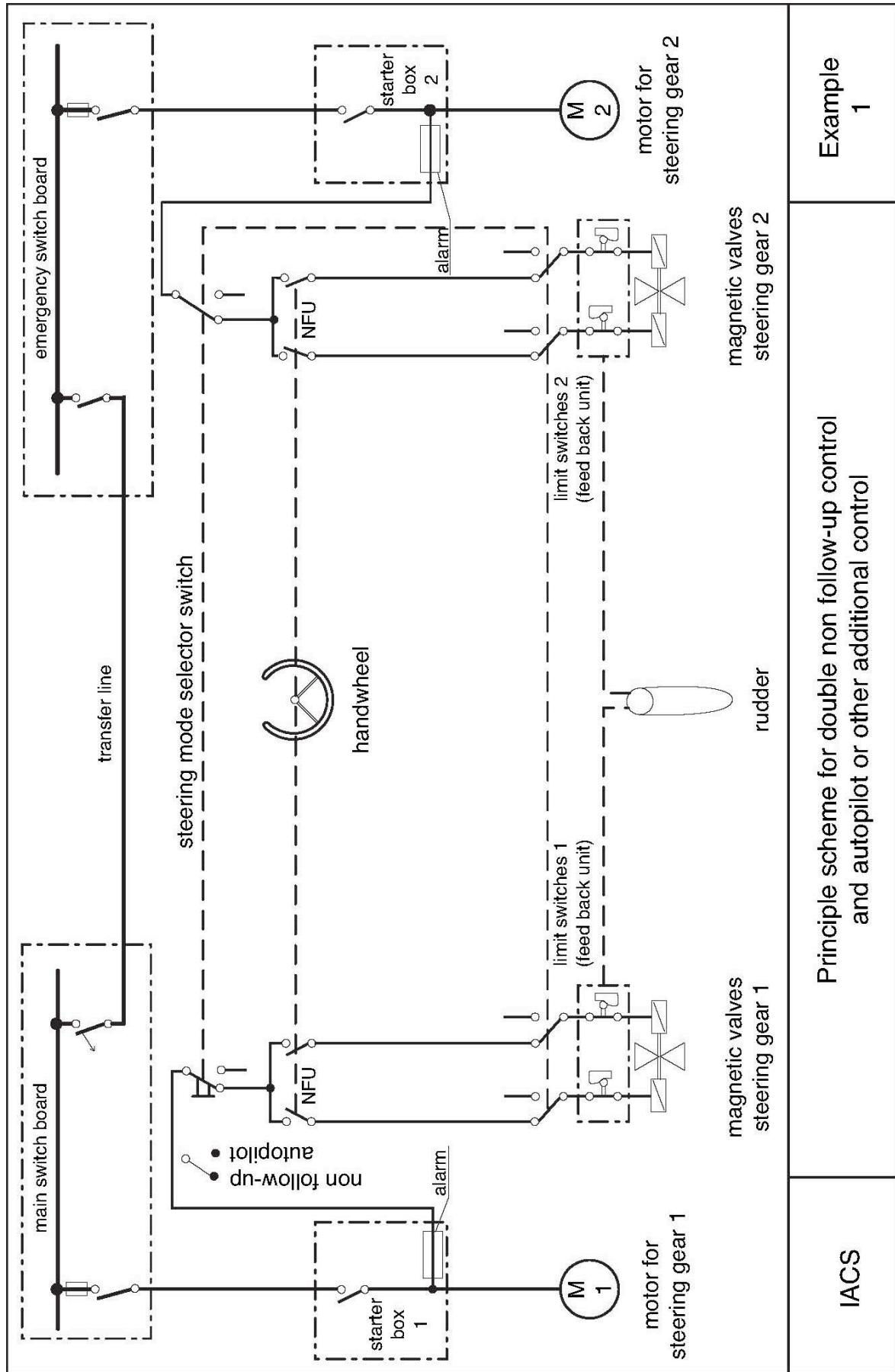

Principle scheme for double non follow-up control and autopilot or other additional control

Example 1

IACS

SC94
(cont)

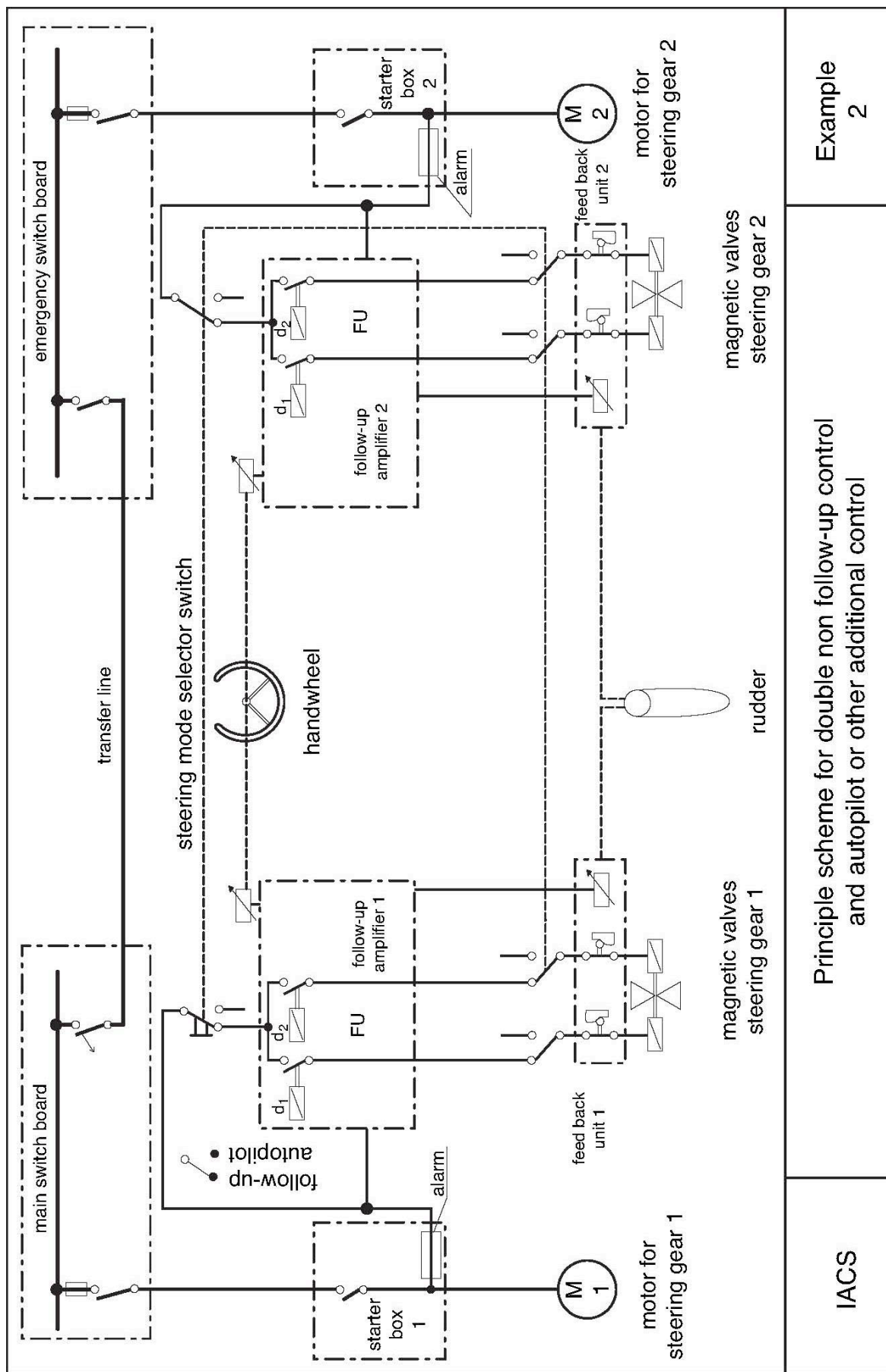

Example
2

Principle scheme for double non follow-up control
and autopilot or other additional control

IACS

SC94
(cont)

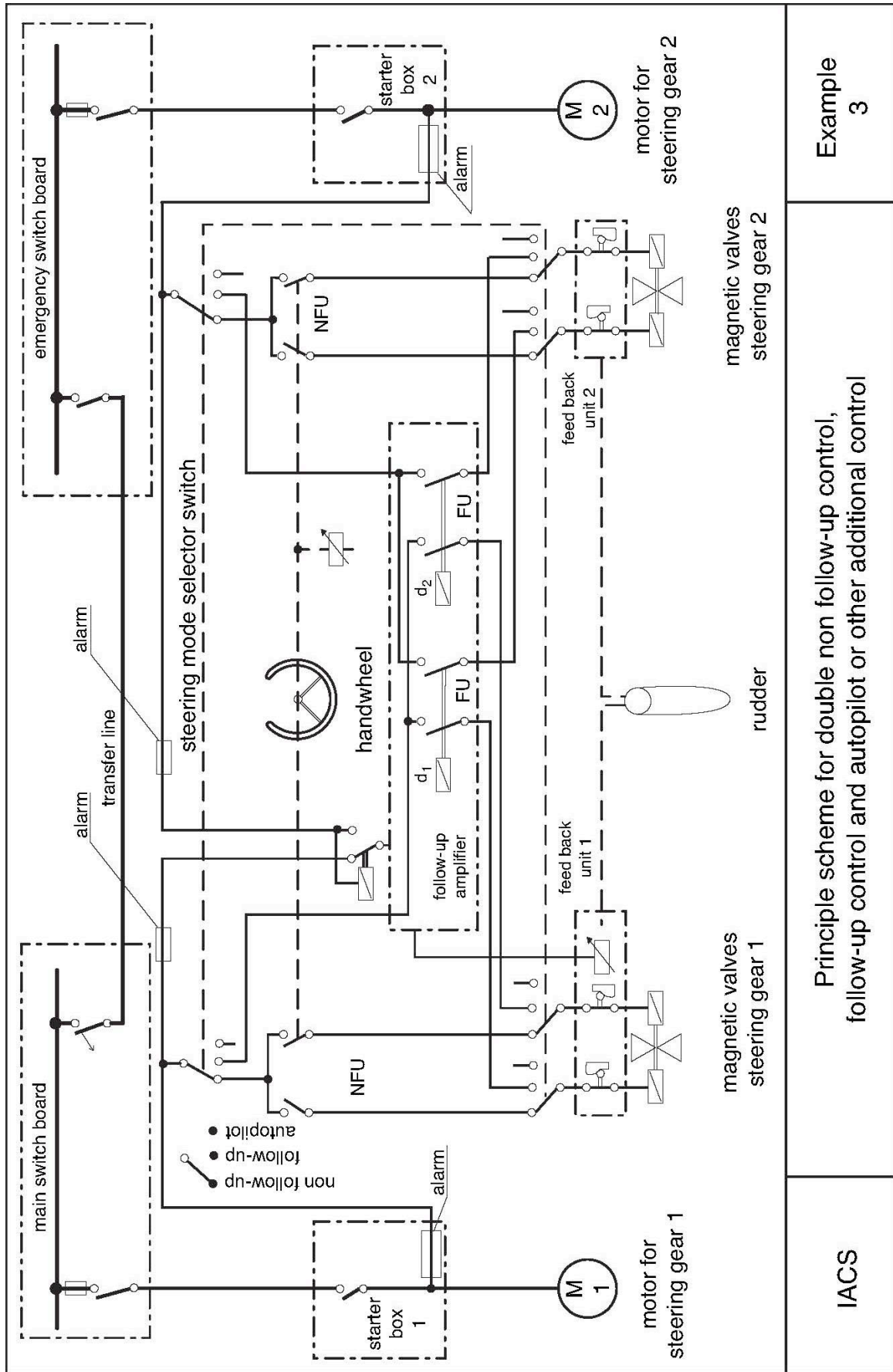

Example
3

Principle scheme for double non follow-up control,
follow-up control and autopilot or other additional control

IACS

End of Document