

S20 Evaluation of Allowable Hold Loading for Bulk Carriers Considering Hold Flooding

(1997)
(Rev. 1
1997)
(Rev.2
Sept.
2000)
(Rev.3
July 2004)
(Rev.4
Feb. 2006)
(Corr.1
Oct 2009)

S20.1 - Application and definitions

Revision 4 of this UR is to be complied with in respect of the flooding of any cargo hold of bulk carriers, as defined in URZ11.2.2, of 150m in length and above, with single deck, topside tanks and hopper tanks, and of single side or double side skin construction, intending to carry solid bulk cargoes having a density 1,0 t/m³, or above, in accordance with Note 2.

The loading in each hold is not to exceed the allowable hold loading in flooded condition, calculated as per S20.4, using the loads given in S20.2 and the shear capacity of the double bottom given in S20.3.

In no case is the allowable hold loading, considering flooding, to be taken greater than the design hold loading in intact condition.

S20.2 - Loading model

S20.2.1 - General

The loads to be considered as acting on the double bottom are those given by the external sea pressures and the combination of the cargo loads with those induced by the flooding of the hold which the double bottom belongs to.

The most severe combinations of cargo induced loads and flooding loads are to be used, depending on the loading conditions included in the loading manual:

- homogeneous loading conditions;
- non homogeneous loading conditions;
- packed cargo conditions (such as steel mill products).

For each loading condition, the maximum bulk cargo density to be carried is to be considered in calculating the allowable hold loading limit.

S20.2.2 - Inner bottom flooding head

The flooding head h_f (see Figure 1) is the distance, in m, measured vertically with the ship in the upright position, from the inner bottom to a level located at a distance d_f , in m, from the baseline equal to:

- a) in general:
- D for the foremost hold
 - 0,9·D for the other holds

Note:

1. The “contracted for construction” date means the date on which the contract to build the vessel is signed between the prospective owner and the shipbuilder. For further details regarding the date of “contract for construction”, refer to IACS Procedural Requirement (PR) No. 29.
2. Revision 4 of this UR is to be applied by IACS Societies to ships contracted for construction ~~from a date commencing not later than~~ on or after 1 July 2006.

S20

cont'd

- b) for ships less than 50,000 tonnes deadweight with Type B freeboard:
- $0,95 \cdot D$ for the foremost hold
 - $0,85 \cdot D$ for the other holds

D being the distance, in m, from the baseline to the freeboard deck at side amidship (see Figure 1).

S20.3 - Shear capacity of the double bottom

The shear capacity C of the double bottom is defined as the sum of the shear strength at each end of:

- all floors adjacent to both hoppers, less one half of the strength of the two floors adjacent to each stool, or transverse bulkhead if no stool is fitted (see Figure 2).
- all double bottom girders adjacent to both stools, or transverse bulkheads if no stool is fitted.

Where in the end holds, girders or floors run out and are not directly attached to the boundary stool or hopper girder, their strength is to be evaluated for the one end only.

Note that the floors and girders to be considered are those inside the hold boundaries formed by the hoppers and stools (or transverse bulkheads if no stool is fitted). The hopper side girders and the floors directly below the connection of the bulkhead stools (or transverse bulkheads if no stool is fitted) to the inner bottom are not to be included.

When the geometry and/or the structural arrangement of the double bottom are such to make the above assumptions inadequate, to the Society's discretion, the shear capacity C of double bottom is to be calculated according to the Society's criteria.

In calculating the shear strength, the net thickness of floors and girders is to be used. The net thickness t_{net} , in mm, is given by:

$$t_{\text{net}} = t - 2,5$$

where:

t = thickness, in mm, of floors and girders.

S20.3.1 - Floor shear strength

The floor shear strength in way of the floor panel adjacent to hoppers S_{f1} , in kN, and the floor shear strength in way of the openings in the outmost bay (i.e. that bay which is closer to hopper) S_{f2} , in kN, are given by the following expressions:

$$S_{f1} = 10^{-3} \cdot A_f \cdot \frac{\tau_a}{\eta_1}$$

$$S_{f2} = 10^{-3} \cdot A_{f,h} \cdot \frac{\tau_a}{\eta_2}$$

where:

A_f = sectional area, in mm^2 , of the floor panel adjacent to hoppers

$A_{f,h}$ = net sectional area, in mm^2 , of the floor panels in way of the openings in the outmost bay (i.e. that bay which is closer to hopper)

S20

cont'd

τ_a = allowable shear stress, in N/mm², to be taken equal to the lesser of

$$\tau_a = \frac{162 \cdot \sigma_F^{0,6}}{(s/t_{\text{net}})^{0,8}} \quad \text{and} \quad \frac{\sigma_F}{\sqrt{3}}$$

For floors adjacent to the stools or transverse bulkheads, as identified in S20.3 τ_a may be taken $\sigma_F / \sqrt{3}$

σ_F = minimum upper yield stress, in N/mm², of the material

s = spacing of stiffening members, in mm, of panel under consideration

η_1 = 1,10

η_2 = 1,20

η_2 may be reduced, to the Society's discretion, down to 1.10 where appropriate reinforcements are fitted to the Society's satisfaction

S20.3.2 - Girder shear strength

The girder shear strength in way of the girder panel adjacent to stools (or transverse bulkheads, if no stool is fitted) S_{g1} , in kN, and the girder shear strength in way of the largest opening in the outmost bay (i.e. that bay which is closer to stool, or transverse bulkhead, if no stool is fitted) S_{g2} , in kN, are given by the following expressions:

$$S_{g1} = 10^{-3} \cdot A_g \cdot \frac{\tau_a}{\eta_1}$$

$$S_{g2} = 10^{-3} \cdot A_{g,h} \cdot \frac{\tau_a}{\eta_2}$$

where:

A_g = minimum sectional area, in mm², of the girder panel adjacent to stools (or transverse bulkheads, if no stool is fitted)

$A_{g,h}$ = net sectional area, in mm², of the girder panel in way of the largest opening in the outmost bay (i.e. that bay which is closer to stool, or transverse bulkhead, if no stool is fitted)

τ_a = allowable shear stress, in N/mm², as given in S20.3.1

η_1 = 1,10

η_2 = 1,15

η_2 may be reduced, to the Society's discretion, down to 1.10 where appropriate reinforcements are fitted to the Society's satisfaction

S20

cont'd

S20.4 - Allowable hold loading

The allowable hold loading W , in tonnes, is given by:

$$W = \rho_c \cdot V \cdot \frac{1}{F}$$

where:

F = 1,1 in general
1,05 for steel mill products

ρ_c = cargo density, in t/m^3 ; for bulk cargoes see S20.2.1; for steel products, ρ_c is to be taken as the density of steel

V = volume, in m^3 , occupied by cargo at a level h_1

$$h_1 = \frac{X}{\rho_c \cdot g}$$

X = for bulk cargoes the lesser of X_1 and X_2 given by:

$$X_1 = \frac{Z + \rho \cdot g \cdot (E - h_f)}{1 + \frac{\rho}{\rho_c}(\text{perm} - 1)}$$

$$X_2 = Z + \rho \cdot g \cdot (E - h_f \cdot \text{perm})$$

X = for steel products, X may be taken as X_1 , using $\text{perm} = 0$

ρ = sea water density, in t/m^3

g = 9.81 m/s^2 , gravity acceleration

E = ship immersion in m for flooded hold condition = $d_f - 0,1D$

d_f, D = as given in S20.2.2

h_f = flooding head, in m, as defined in S20.2.2

perm = cargo permeability, (i.e. the ratio between the voids within the cargo mass and the volume occupied by the cargo); it needs not be taken greater than 0.3.

Z = the lesser of Z_1 and Z_2 given by:

$$Z_1 = \frac{C_h}{A_{DB,h}}$$

$$Z_2 = \frac{C_e}{A_{DB,e}}$$

S20
 cont'd

C_h = shear capacity of the double bottom, in kN, as defined in S20.3, considering, for each floor, the lesser of the shear strengths S_{f1} and S_{f2} (see S20.3.1) and, for each girder, the lesser of the shear strengths S_{g1} and S_{g2} (see S20.3.2)

C_e = shear capacity of the double bottom, in kN, as defined in S20.3, considering, for each floor, the shear strength S_{f1} (see S20.3.1) and, for each girder, the lesser of the shear strengths S_{g1} and S_{g2} (see S20.3.2)

$$A_{DB,h} = \sum_{i=1}^{i=n} S_i \cdot B_{DB,i}$$

$$A_{DB,e} = \sum_{i=1}^{i=n} S_i \cdot (B_{DB} - s_1)$$

n = number of floors between stools (or transverse bulkheads, if no stool is fitted)

S_i = space of i th-floor, in m

$B_{DB,i}$ = $B_{DB} - s_1$ for floors whose shear strength is given by S_{f1} (see S20.3.1)

$B_{DB,i}$ = $B_{DB,h}$ for floors whose shear strength is given by S_{f2} (see S20.3.1)

B_{DB} = breadth of double bottom, in m, between hoppers (see Figure 3)

$B_{DB,h}$ = distance, in m, between the two considered opening (see Figure 3)

s_1 = spacing, in m, of double bottom longitudinals adjacent to hoppers

Figure 1

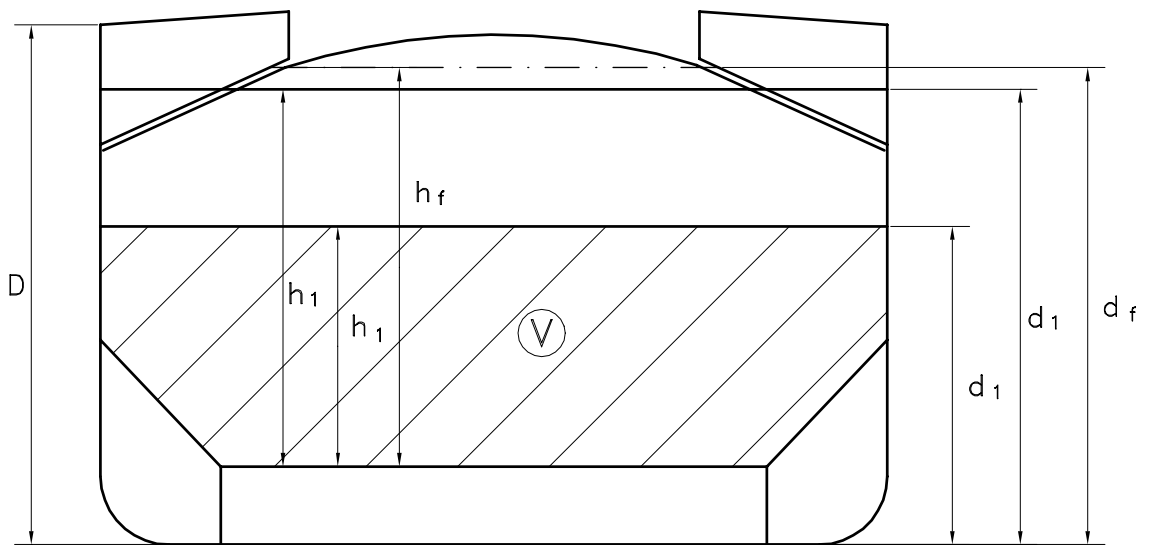

$V =$ Volume of cargo

S20
cont'd

Figure 2

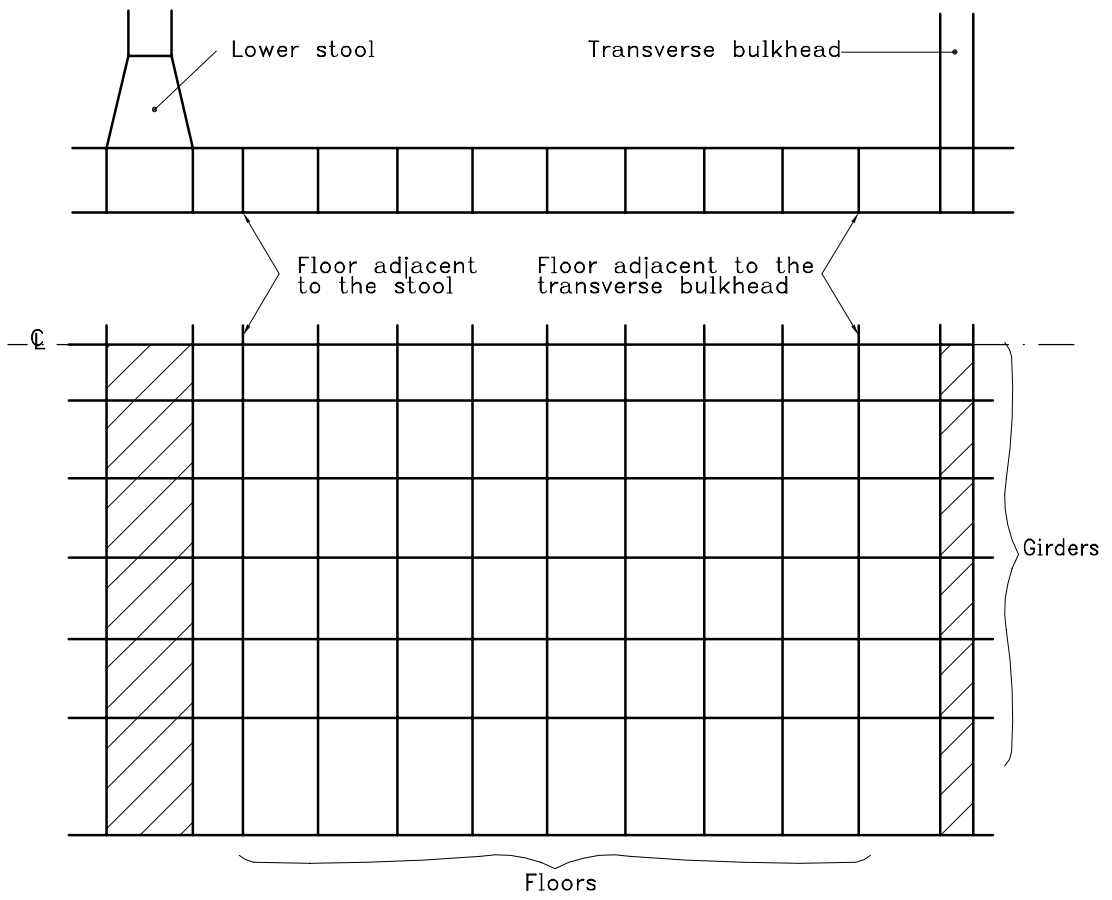
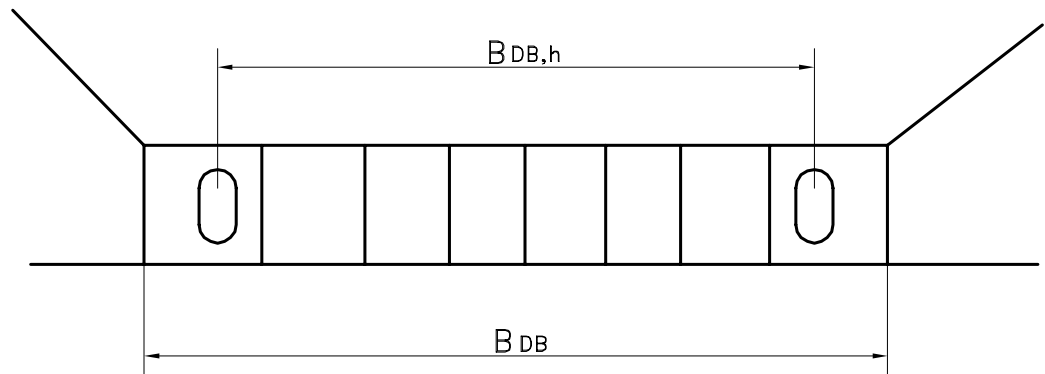

Figure 3



END