

I2 Structural Requirements for Polar Class Ships

(August 2006)
(Rev.1 Jan 2007)
(Corr.1 Oct 2007)
(Rev.2 Nov 2010)

I2.1 Application *

I2.1.1 These requirements are to be applied to polar class ships according to IACS UR 11.

I2.2 Hull Areas

I2.2.1 The hull of all polar class ships is divided into areas reflecting the magnitude of the loads that are expected to act upon them. In the longitudinal direction, there are four regions: Bow, Bow Intermediate, Midbody and Stern. The Bow Intermediate, Midbody and Stern regions are further divided in the vertical direction into the Bottom, Lower and Icebelt regions. The extent of each Hull Area is illustrated in Figure 1.

Figure 1 - Hull Area Extents

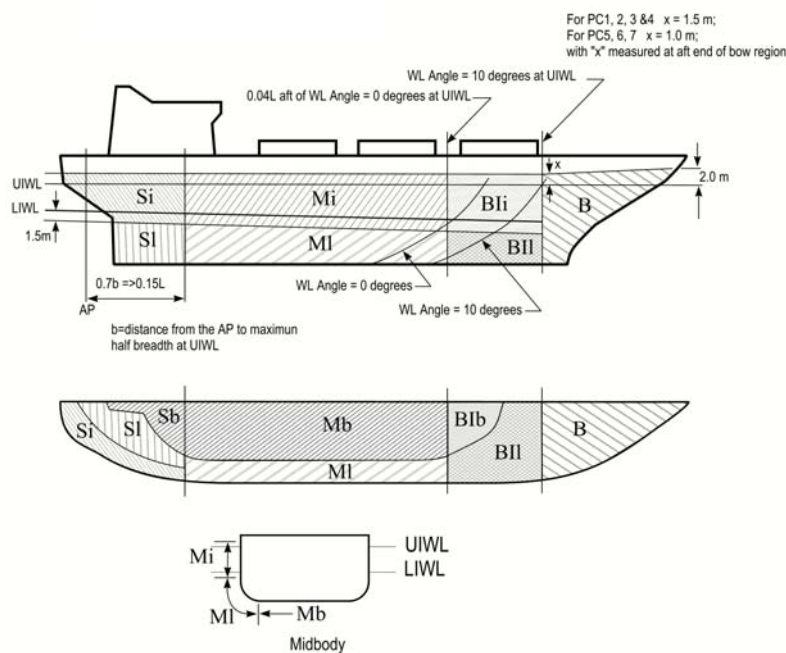

Formatted: Centered

Deleted: ¶

Deleted: ¶

I2.2.2 The upper ice waterline (UIWL) and lower ice waterline (LIWL) are as defined in I1.3.¶

* Note:

1. This UR is to be uniformly applied by IACS Societies on ships contracted for construction on and after 1 March 2008.
2. Rev.2 of this UR is to be uniformly implemented by the IACS Societies on ships contracted for construction on or after 1 January 2012.
3. The "contracted for construction" date means the date on which the contract to build the vessel is signed between the prospective owner and the shipbuilder. For further details regarding the date of "contract for construction", refer to IACS Procedural Requirement (PR) No. 29.

Deleted: I2.2.3 Figure 1 notwithstanding, at no time is the boundary between the Bow and Bow Intermediate regions to be forward of the intersection point of the line of the stem and the ship baseline.¶

Deleted: ¶

Deleted: 2.

Formatted: Strikethrough

Deleted: 1

Deleted: 2007

Deleted: /Corr.1, 2007

12.2.2 The upper ice waterline (UIWL) and lower ice waterline (LIWL) are as defined in I1.3.

12.2.3 Figure 1 notwithstanding, at no time is the boundary between the Bow and Bow Intermediate regions to be forward of the intersection point of the line of the stem and the ship baseline.

12.2.4 Figure 1 notwithstanding, the aft boundary of the Bow region need not be more than 0.45 L aft of the forward perpendicular (FP).

12.2.5 The boundary between the bottom and lower regions is to be taken at the point where the shell is inclined 7° from horizontal.

12.2.6 If a ship is intended to operate astern in ice regions, the aft section of the ship is to be designed using the Bow and Bow Intermediate hull area requirements.

Formatted: Body Text

Deleted: ¶

12.3 Design Ice Loads

12.3.1 General

(i) For ships of all Polar Classes, a glancing impact on the bow is the design scenario for determining the scantlings required to resist ice loads.

(ii) The design ice load is characterized by an average pressure (P_{avg}) uniformly distributed over a rectangular load patch of height (b) and width (w).

(iii) Within the Bow area of all polar classes, and within the Bow Intermediate Icebelt area of polar classes PC6 and PC7, the ice load parameters are functions of the actual bow shape. To determine the ice load parameters (P_{avg} , b and w), it is required to calculate the following ice load characteristics for sub-regions of the bow area; shape coefficient (f_{a_i}), total glancing impact force (F_i), line load (Q_i) and pressure (P_i).

(iv) In other ice-strengthened areas, the ice load parameters (P_{avg} , b_{NonBow} and w_{NonBow}) are determined independently of the hull shape and based on a fixed load patch aspect ratio, $AR = 3.6$.

(v) Design ice forces calculated according to 12.3.2 are only valid for vessels with icebreaking forms. Design ice forces for any other bow forms are to be specially considered by the member society.

(vi) Ship structures that are not directly subjected to ice loads may still experience inertial loads of stowed cargo and equipment resulting from ship/ice interaction. These inertial loads, based on accelerations determined by each member society, are to be considered in the design of these structures.

Deleted: ¶

<sp>¶

¶

* Note: ¶

¶

1. This UR is to be uniformly applied by IACS Societies on ships contracted for construction on and after 1 March 2008. ¶

¶

2. The "contracted for construction" date means the date on which the contract to build the vessel is signed between the prospective owner and the shipbuilder. For further details regarding the date of "contract for construction", refer to IACS Procedural Requirement (PR) No. 29. ¶

¶

12.3.2 Glancing Impact Load Characteristics

(i) The parameters defining the glancing impact load characteristics are reflected in the Class Factors listed in Table 1.

Formatted: Indent: Left: 0 cm

Deleted: 1

Deleted: 2007

Table 1 - Class Factors

Polar Class	Crushing Failure Class Factor (CF _C)	Flexural Failure Class Factor (CF _F)	Load Patch Dimensions Class Factor (CF _D)	Displacement Class Factor (CF _{DIS})	Longitudinal Strength Class Factor (CF _L)
PC1	17.69	68.60	2.01	250	7.46
PC2	9.89	46.80	1.75	210	5.46
PC3	6.06	21.17	1.53	180	4.17
PC4	4.50	13.48	1.42	130	3.15
PC5	3.10	9.00	1.31	70	2.50
PC6	2.40	5.49	1.17	40	2.37
PC7	1.80	4.06	1.11	22	1.81

I2.3.2.1 Bow Area

(i) In the Bow area, the force (F), line load (Q), pressure (P) and load patch aspect ratio (AR) associated with the glancing impact load scenario are functions of the hull angles measured at the upper ice waterline (UIWL). The influence of the hull angles is captured through calculation of a bow shape coefficient (fa). The hull angles are defined in Figure 2.

Figure 2 - Definition of Hull Angles

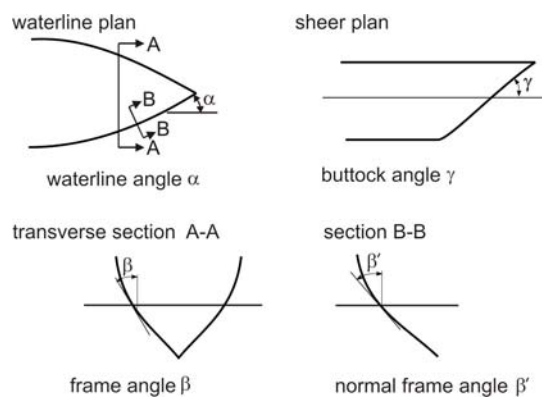

Formatted: Widow/Orphan control, Tabs: Not at 0 cm

Note: β' = normal frame angle at upper ice waterline [deg]

α = upper ice waterline angle [deg]

γ = buttock angle at upper ice waterline (angle of buttock line measured from horizontal) [deg]

$\tan(\beta) = \tan(\alpha)/\tan(\gamma)$

$\tan(\beta') = \tan(\beta) \cdot \cos(\alpha)$

Formatted: Finnish

Formatted: Finnish

Formatted: Finnish

Formatted: Finnish

(ii) The waterline length of the bow region is generally to be divided into 4 sub-regions of equal length. The force (F), line load (Q), pressure (P) and load patch aspect ratio (AR) are to be calculated with respect to the mid-length position of each sub-region (each maximum of F, Q and P is to be used in the calculation of the ice load parameters P_{avg} , b and w).

(iii) The Bow area load characteristics are determined as follows:

Deleted: 1

Deleted: 2007

I2

(cont)

(a) Shape coefficient, fa_i , is to be taken as

$$fa_i = \text{minimum} (fa_{i,1} ; fa_{i,2} ; fa_{i,3}) \quad \text{[Equation 1]}$$

$$\text{where } fa_{i,1} = (0.097 - 0.68 \cdot (x/L - 0.15)^2) \cdot \alpha_i / (\beta'_i)^{0.5} \quad \text{[Equation 2]}$$

$$fa_{i,2} = 1.2 \cdot CF_F / (\sin(\beta'_i) \cdot CF_C \cdot D^{0.64}) \quad \text{[Equation 3]}$$

$$fa_{i,3} = 0.60 \quad \text{[Equation 4]}$$

i = sub-region considered

L = ship length as defined in UR S2.1, but measured on the upper ice waterline (UIWL) [m]

x = distance from the forward perpendicular (FP) to station under consideration [m]

 α = waterline angle [deg], see Figure 2 β' = normal frame angle [deg], see Figure 2

D = ship displacement [kt], not to be taken less than 5 kt

 CF_C = Crushing Failure Class Factor from Table 1 CF_F = Flexural Failure Class Factor from Table 1

(b) Force, F:

$$F_i = fa_i \cdot CF_C \cdot D^{0.64} \text{ [MN]} \quad \text{[Equation 5]}$$

where i = sub-region considered

 fa_i = shape coefficient of sub-region i CF_C = Crushing Failure Class Factor from Table 1

D = ship displacement [kt], not to be taken less than 5 kt

(c) Load patch aspect ratio, AR:

$$AR_i = 7.46 \cdot \sin(\beta'_i) \geq 1.3 \quad \text{[Equation 6]}$$

where i = sub-region considered

 β'_i = normal frame angle of sub-region i [deg]

(d) Line load, Q:

$$Q_i = F_i^{0.61} \cdot CF_D / AR_i^{0.35} \text{ [MN/m]} \quad \text{[Equation 7]}$$

where i = sub-region considered

 F_i = force of sub-region i [MN] CF_D = Load Patch Dimensions Class Factor from Table 1 AR_i = load patch aspect ratio of sub-region i

(e) Pressure, P:

$$P_i = F_i^{0.22} \cdot CF_D^2 \cdot AR_i^{0.3} \text{ [MPa]} \quad \text{[Equation 8]}$$

where i = sub-region considered

 F_i = force of sub-region i [MN] CF_D = load patch dimensions class factor from Table 1 AR_i = load patch aspect ratio of sub-region i

Deleted: *

Deleted: *

Deleted: *

Deleted: *

Deleted: at

Deleted: *

Deleted: *

Deleted: *

Deleted: *

Deleted: *

Deleted: *

Deleted: 1

Deleted: 2007

I2 (cont)

I2.3.2.2 Hull Areas Other Than the Bow

(i) In the hull areas other than the bow, the force (F_{NonBow}) and line load (Q_{NonBow}) used in the determination of the load patch dimensions (b_{NonBow} , w_{NonBow}) and design pressure (P_{avg}) are determined as follows:

(a) Force, F_{NonBow} :

$$F_{\text{NonBow}} = 0.36 \cdot CF_C \cdot DF \text{ [MN]} \quad \text{[Equation 9]}$$

Deleted: *

Deleted: *

where CF_C = Crushing Force Class Factor from Table 1

DF = ship displacement factor

$$= D^{0.64}$$

$$= CF_{\text{DIS}}^{0.64} + 0.10 \cdot (D - CF_{\text{DIS}}) \quad \begin{matrix} \text{if } D \leq CF_{\text{DIS}} \\ \text{if } D > CF_{\text{DIS}} \end{matrix}$$

D = ship displacement [kt], not to be taken less than 10 kt

CF_{DIS} = Displacement Class Factor from Table 1

Deleted: .

(b) Line Load, Q_{NonBow} :

$$Q_{\text{NonBow}} = 0.639 \cdot F_{\text{NonBow}}^{0.61} \cdot CF_D \text{ [MN/m]} \quad \text{[Equation 10]}$$

Deleted: *

Deleted: *

where F_{NonBow} = force from Equation 9 [MN]

CF_D = Load Patch Dimensions Class Factor from Table 1

I2.3.3 Design Load Patch

(i) In the Bow area, and the Bow Intermediate Icebelt area for ships with class notation PC6 and PC7, the design load patch has dimensions of width, w_{Bow} , and height, b_{Bow} , defined as follows:

$$w_{\text{Bow}} = F_{\text{Bow}} / Q_{\text{Bow}} \text{ [m]} \quad \text{[Equation 11]}$$

$$b_{\text{Bow}} = Q_{\text{Bow}} / P_{\text{Bow}} \text{ [m]} \quad \text{[Equation 12]}$$

where F_{Bow} = maximum force F_i in the Bow area from Equation 5 [MN]

Q_{Bow} = maximum line load Q_i in the Bow area from Equation 7 [MN/m]

P_{Bow} = maximum pressure P_i in the Bow area from Equation 8 [MPa]

(ii) In hull areas other than those covered by I2.3.3 (i), the design load patch has dimensions of width, w_{NonBow} , and height, b_{NonBow} , defined as follows:

$$w_{\text{NonBow}} = F_{\text{NonBow}} / Q_{\text{NonBow}} \text{ [m]} \quad \text{[Equation 13]}$$

$$b_{\text{NonBow}} = w_{\text{NonBow}} / 3.6 \text{ [m]} \quad \text{[Equation 14]}$$

where F_{NonBow} = force determined using Equation 9 [MN]

Q_{NonBow} = line load determined using Equation 10 [MN/m]

Deleted: 1

Deleted: 2007

I2
(cont)

12.3.4 Pressure Within the Design Load Patch

(i) The average pressure, P_{avg} , within a design load patch is determined as follows:

$$P_{avg} = F / (b \cdot w) \text{ [MPa]} \quad \text{[Equation 15]}$$

where $F = F_{Bow}$ or F_{NonBow} as appropriate for the hull area under consideration [MN]
 $b = b_{Bow}$ or b_{NonBow} as appropriate for the hull area under consideration [m]
 $w = w_{Bow}$ or w_{NonBow} as appropriate for the hull area under consideration [m]

Deleted: *

(ii) Areas of higher, concentrated pressure exist within the load patch. In general, smaller areas have higher local pressures. Accordingly, the peak pressure factors listed in Table 2 are used to account for the pressure concentration on localized structural members.

Table 2 - Peak Pressure Factors

Structural Member		Peak Pressure Factor (PPF _i)
Plating	Transversely-Framed	$PPF_p = (1.8 - s) \geq 1.2$
	Longitudinally-Framed	$PPF_p = (2.2 - 1.2 \cdot s) \geq 1.5$
Frames in Transverse Framing Systems	With Load Distributing Stringers	$PPF_t = (1.6 - s) \geq 1.0$
	With No Load Distributing Stringers	$PPF_t = (1.8 - s) \geq 1.2$
Load Carrying Stringers		$PPF_s = 1$, if $S_w \geq 0.5 \cdot w$
Side and Bottom Longitudinals		$PPF_s = 2.0 - 2.0 \cdot S_w / w$
Web Frames		if $S_w < (0.5 \cdot w)$
where: s = frame or longitudinal spacing [m] S_w = web frame spacing [m] w = ice load patch width [m]		

Deleted: *

Deleted: *

Deleted: *

Deleted: *

12.3.5 Hull Area Factors

(i) Associated with each hull area is an Area Factor that reflects the relative magnitude of the load expected in that area. The Area Factor (AF) for each hull area is listed in Table 3.

(ii) In the event that a structural member spans across the boundary of a hull area, the largest hull area factor is to be used in the scantling determination of the member.

(iii) Due to their increased manoeuvrability, ships having propulsion arrangements with azimuthing thruster(s) or "podded" propellers shall have specially considered Stern Icebelt (S_i) and Stern Lower (S_l) hull area factors.

Deleted: 1

Deleted: 2007

I2 (cont)

s = transverse frame spacing in transversely-framed ships or longitudinal frame spacing in longitudinally-framed ships [m]
 AF = Hull Area Factor from Table 3
 PPF_p = Peak Pressure Factor from Table 2
 P_{avg} = average patch pressure according to Equation 15 [MPa]
 σ_y = minimum upper yield stress of the material [N/mm²]
 b = height of design load patch [m], where $b \leq (l - s/4)$ in the case of Equation 17a
 l = distance between frame supports, i.e. equal to the frame span as given in 12.5.5, but not reduced for any fitted end brackets [m]. When a load-distributing stringer is fitted, the length l need not be taken larger than the distance from the stringer to the most distant frame support.

Deleted: [

Deleted:]

Figure 3 - Shell Framing Angle Ω

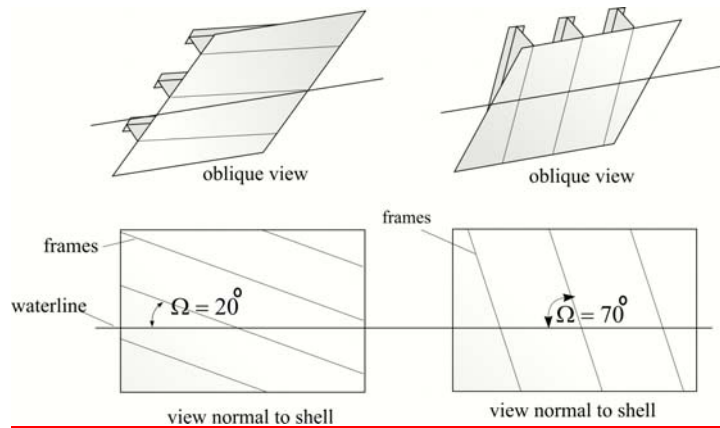

Formatted: Centered

I2.5 Framing - General

I2.5.1 Framing members of Polar class ships are to be designed to withstand the ice loads defined in 12.3.

I2.5.2 The term "framing member" refers to transverse and longitudinal local frames, load-carrying stringers and web frames in the areas of the hull exposed to ice pressure, see Figure 1. Where load-distributing stringers have been fitted, the arrangement and scantlings of these are to be in accordance with the requirements of each member society.

I2.5.3 The strength of a framing member is dependent upon the fixity that is provided at its supports. Fixity can be assumed where framing members are either continuous through the support or attached to a supporting section with a connection bracket. In other cases, simple support is to be assumed unless the connection can be demonstrated to provide significant rotational restraint. Fixity is to be ensured at the support of any framing which terminates within an ice-strengthened area.

I2.5.4 The details of framing member intersection with other framing members, including plated structures, as well as the details for securing the ends of framing members at supporting sections, are to be in accordance with the requirements of each member society.

Deleted: 1

Deleted: 2007

I2 (cont)

I2.5.5 The design span of a framing member is to be determined on the basis of its moulded length. If brackets are fitted, the design span may be reduced in accordance with the usual practice of each member society. Brackets are to be configured to ensure stability in the elastic and post-yield response regions.

I2.5.6 When calculating the section modulus and shear area of a framing member, net thicknesses of the web, flange (if fitted) and attached shell plating are to be used. The shear area of a framing member may include that material contained over the full depth of the member, i.e. web area including portion of flange, if fitted, but excluding attached shell plating.

I2.5.7 The actual net effective shear area, A_w , of a framing member is given by:

$$A_w = h \cdot t_{wn} \cdot \sin \varphi_w / 100 \text{ [cm}^2\text{]}$$

[Equation 18]

Formatted: Lowered by 5 pt

h = height of stiffener [mm], see Figure 4

t_{wn} = net web thickness [mm]

$$= t_w - t_c$$

t_w = as built web thickness [mm], see Figure 4

t_c = corrosion deduction [mm] to be subtracted from the web and flange thickness (as specified by each member society, but not less than t_s as required by I2.11.3).

φ_w = smallest angle between shell plate and stiffener web, measured at the midspan of the stiffener, see Figure 4. The angle φ_w may be taken as 90 degrees provided the smallest angle is not less than 75 degrees.

Figure 4 - Stiffener geometry

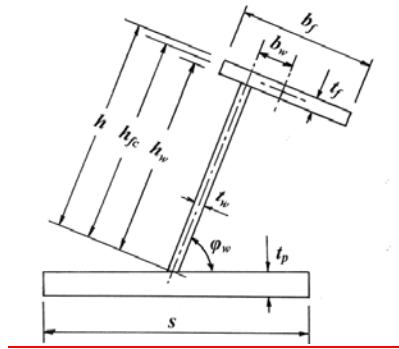

Formatted: Centered

I2.5.8 When the cross-sectional area of the attached plate flange exceeds the cross-sectional area of the local frame, the actual net effective plastic section modulus, Z_p , is given by:

$$Z_p = A_{pn} \cdot t_{pn} / 20 + \frac{h_w^2 \cdot t_{wn} \cdot \sin \varphi_w}{2000} + A_{fn} \cdot (h_{fc} \cdot \sin \varphi_w - b_w \cdot \cos \varphi_w) / 10 \text{ [cm}^3\text{]}$$

[Equation 19]

Formatted: Lowered by 13 pt

h , t_{wn} , t_c , and φ_w are as given in I2.5.7 and s as given in I2.4.2.

A_{pn} = net cross-sectional area of **the local frame**, [cm²]

t_{pn} = fitted net shell plate thickness [mm] (shall comply with t_{net} as required by I2.4.2)

h_w = height of local frame web [mm], see Figure 4

A_{fn} = net cross-sectional area of local frame flange [cm²]

h_{fc} = height of local frame measured to centre of the flange area [mm], see Figure 4

b_w = distance from mid thickness plane of local frame web to the centre of the flange area [mm], see Figure 4

Deleted: attached plate

Deleted: (equal to $t_{pn} \cdot s \cdot 10$, but not to be taken greater than the net cross-sectional area of the local frame)

Deleted: 1

Deleted: 2007

- $A_{1B} = (1 - 1 / (2 \cdot a_1 \cdot Y)) / (0.275 + 1.44 \cdot k_z^{0.7})$
 $j = 1$ for framing with one simple support outside the ice-strengthened areas
 $= 2$ for framing without any simple supports
 $a_1 = A_t / A_w$
 A_t = minimum shear area of transverse frame as given in I2.6.2 [cm²]
 A_w = effective net shear area of transverse frame (calculated according to I2.5.7) [cm²]
 $k_w = 1 / (1 + 2 \cdot A_{fn} / A_w)$ with A_{fn} as given in I2.5.8
 $k_z = z_p / Z_p$ in general
 $= 0.0$ when the frame is arranged with end bracket
 z_p = sum of individual plastic section moduli of flange and shell plate as fitted [cm³]
 $= (b_f \cdot t_{fn}^2 / 4 + b_{eff} \cdot t_{pn}^2 / 4) / 1000$
 b_f = flange breadth [mm], see Figure 4
 t_{fn} = net flange thickness [mm]
 $= t_f - t_c$ (t_c as given in I2.5.7)
 t_f = as-built flange thickness [mm], see Figure 4
 t_{pn} = the fitted net shell plate thickness [mm] (not to be less than t_{net} as given in I2.4)
 b_{eff} = effective width of shell plate flange [mm]
 $= 500 \cdot s$
 Z_p = net effective plastic section modulus of transverse frame (calculated according to I2.5.8) [cm³]

Deleted: *

Deleted: *

Deleted: *

Deleted: *

Deleted: i

Deleted: *

Deleted: *

Formatted: Indent: Left: 0.25 cm

I2.6.4 The scantlings of the frame are to meet the structural stability requirements of I2.9.

I2.7 Framing - Side Longitudinals (Longitudinally-Framed Ships)

I2.7.1 Side longitudinals are to be dimensioned such that the combined effects of shear and bending do not exceed the plastic strength of the member. The plastic strength is defined by the magnitude of midspan load that causes the development of a plastic collapse mechanism.

I2.7.2 The actual net effective shear area of the frame, A_w , as defined in I2.5.7, is to comply with the following condition: $A_w \geq A_L$, where:

$$A_L = 100^2 \cdot (AF \cdot PPF_s \cdot P_{avg}) \cdot 0.5 \cdot b_1 \cdot a / (0.577 \cdot \sigma_y) \text{ [cm}^2\text{]} \quad \text{[Equation 24]}$$

where AF = Hull Area Factor from Table 3

PPF_s = Peak Pressure Factor from Table 2

P_{avg} = average pressure within load patch according to Equation 15 [MPa]

$b_1 = k_o \cdot b_2$ [m]

$k_o = 1 - 0.3 / b'$

$b' = b / s$

b = height of design ice load patch from Equation 12 or 14 [m]

s = spacing of longitudinal frames [m]

$b_2 = b \cdot (1 - 0.25 \cdot b')$ [m], if $b' < 2$

$= s$ [m], if $b' \geq 2$

a = longitudinal design span as given in I2.5.5 [m]

σ_y = minimum upper yield stress of the material [N/mm²]

Deleted: *

Deleted: *

Deleted: *

Deleted: *

Deleted: *

Deleted: *

Deleted: *

Deleted: *

Deleted: *

Deleted: *

I2.7.3 The actual net effective plastic section modulus of the plate/stiffener combination, Z_p , as defined in I2.5.8, is to comply with the following condition: $Z_p \geq Z_{pL}$, where:

Deleted: 1

Deleted: 2007

I2
(cont)

$$Z_{pL} = 100^3 \cdot (AF \cdot PPF_s \cdot P_{avg}) \cdot b_1 \cdot a^2 \cdot A_4 / (8 \cdot \sigma_y) \text{ [cm}^3\text{]} \quad \text{[Equation 25]}$$

where AF, PPF_s, P_{avg}, b₁, a and σ_y are as given in I2.7.2

$$A_4 = 1 / (2 + k_{wl} \cdot [(1 - a_4^2)^{0.5} - 1])$$

$$a_4 = A_L / A_w$$

A_L = minimum shear area for longitudinal as given in I2.7.2 [cm²]

A_w = net effective shear area of longitudinal (calculated according to I2.5.7) [cm²]

k_{wl} = 1 / (1 + 2 · A_{fn} / A_w) with A_{fn} as given in I2.5.8

I2.7.4 The scantlings of the longitudinals are to meet the structural stability requirements of I2.9.

- Deleted: *
- Deleted: *
- Deleted: *
- Deleted: *
- Deleted: *
- Deleted: *
- Deleted: *
- Deleted: *
- Deleted: *

I2.8 Framing - Web Frame and Load-Carrying Stringers

I2.8.1 Web frames and load-carrying stringers are to be designed to withstand the ice load patch as defined in I2.3. The load patch is to be applied at locations where the capacity of these members under the combined effects of bending and shear is minimised.

I2.8.2 Web frames and load-carrying stringers are to be dimensioned such that the combined effects of shear and bending do not exceed the limit state(s) defined by each member society. Where these members form part of a structural grillage system, appropriate methods of analysis are to be used. Where the structural configuration is such that members do not form part of a grillage system, the appropriate peak pressure factor (PPF) from Table 2 is to be used. Special attention is to be paid to the shear capacity in way of lightening holes and cut-outs in way of intersecting members.

I2.8.3 The scantlings of web frames and load-carrying stringers are to meet the structural stability requirements of I2.9.

I2.9 Framing - Structural Stability

I2.9.1 To prevent local buckling in the web, the ratio of web height (h_w) to net web thickness (t_{wn}) of any framing member is not to exceed:

For flat bar sections: $h_w / t_{wn} \leq 282 / (\sigma_y)^{0.5}$

For bulb, tee and angle sections: $h_w / t_{wn} \leq 805 / (\sigma_y)^{0.5}$

where h_w = web height

t_{wn} = net web thickness

σ_y = minimum upper yield stress of the material [N/mm²]

I2.9.2 Framing members for which it is not practicable to meet the requirements of I2.9.1 (e.g. load carrying stringers or deep web frames) are required to have their webs effectively stiffened. The scantlings of the web stiffeners are to ensure the structural stability of the framing member. The minimum net web thickness for these framing members is given by:

$$t_{wn} = 2.63 \times 10^{-3} \cdot c_1 \sqrt{\sigma_y / (5.34 + 4 \cdot (c_1 / c_2)^2)} \text{ [mm]} \quad \text{[Equation 26]}$$

where c₁ = h_w - 0.8 · h [mm]

h_w = web height of stringer / web frame [mm] (see Figure 5)

- Formatted: Lowered by 5 pt
- Formatted: Lowered by 8 pt
- Deleted: ¶
- Deleted: x
- Deleted: 10⁻³ ·
- Deleted: *
- Deleted: c₁ ·
- Deleted: *
- Deleted: (σ_y / (5.34 + 4 ·
- Deleted: *
- Deleted: (c₁ / c₂)²)^{0.5} [mm] · [Equation 26]¶
- Formatted: Superscript
- Deleted: *
- Deleted: 1
- Deleted: 2007

I2 (cont)

h = height of framing member penetrating the member under consideration (0 if no such framing member) [mm] (see Figure 5)
 c_2 = spacing between supporting structure oriented perpendicular to the member under consideration [mm] (see Figure 5)
 σ_y = minimum upper yield stress of the material [N/mm²]

Figure 5 - Parameter Definition for Web Stiffening

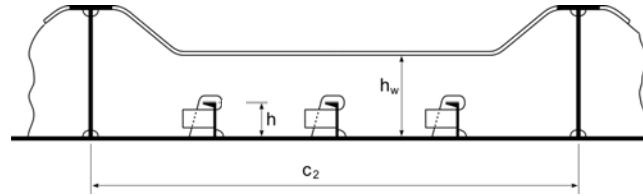

Formatted: Centered

12.9.3 In addition, the following is to be satisfied:

$$t_{wn} \geq 0.35 \cdot t_{pn} \cdot (\sigma_y / 235)^{0.5}$$

where σ_y = minimum upper yield stress of the shell plate in way of the framing member, [N/mm²]

t_{wn} = net thickness of the web [mm]

t_{pn} = net thickness of the shell plate in way of the framing member [mm]

Deleted: *

Deleted: *

Formatted: Indent: Left: 0 cm, Hanging: 2.25 cm

Deleted: material

12.9.4 To prevent local flange buckling of welded profiles, the following are to be satisfied:

(i) The flange width, b_f [mm], shall not be less than five times the net thickness of the web, t_{wn} .

(ii) The flange outstand, b_{out} [mm], shall meet the following requirement:

$$b_{out} / t_{fn} \leq 155 / (\sigma_y)^{0.5}$$

where t_{fn} = net thickness of flange [mm]

σ_y = minimum upper yield stress of the material [N/mm²]

12.10 Plated Structures

12.10.1 Plated structures are those stiffened plate elements in contact with the hull and subject to ice loads. These requirements are applicable to an inboard extent which is the lesser of:

- (i) web height of adjacent parallel web frame or stringer; or
- (ii) 2.5 times the depth of framing that intersects the plated structure

12.10.2 The thickness of the plating and the scantlings of attached stiffeners are to be such that the degree of end fixity necessary for the shell framing is ensured.

12.10.3 The stability of the plated structure is to adequately withstand the ice loads defined in 12.3.

Deleted: 1

Deleted: 2007

I2.11 Corrosion/Abrasion Additions and Steel Renewal

Deleted: ¶

I2.11.1 Effective protection against corrosion and ice-induced abrasion is recommended for all external surfaces of the shell plating for all Polar ships.

I2.11.2 The values of corrosion/abrasion additions, t_s , to be used in determining the shell plate thickness for each Polar Class are listed in Table 4.

I2.11.3 Polar ships are to have a minimum corrosion/abrasion addition of $t_s = 1.0$ mm applied to all internal structures within the ice-strengthened hull areas, including plated members adjacent to the shell, as well as stiffener webs and flanges.

Table 4 - Corrosion/Abrasion Additions for Shell Plating

Hull Area	t_s [mm]					
	With Effective Protection			Without Effective Protection		
	PC1 - PC3	PC4 & PC5	PC6 & PC7	PC1 - PC3	PC4 & PC5	PC6 & PC7
Bow; Bow Intermediate Icebelt	3.5	2.5	2.0	7.0	5.0	4.0
Bow Intermediate Lower; Midbody & Stern Icebelt	2.5	2.0	2.0	5.0	4.0	3.0
Midbody & Stern Lower; Bottom	2.0	2.0	2.0	4.0	3.0	2.5

Deleted: Other Areas ... [1]

I2.11.4 Steel renewal for ice strengthened structures is required when the gauged thickness is less than $t_{net} + 0.5$ mm.

Deleted: ¶

I2.12 Materials

I2.12.1 Plating materials for hull structures are to be not less than those given in Tables 6 and 7 based on the as-built thickness of the material, the Polar ice class notation assigned to the ship and the Material Class of structural members according to I2.12.2.

Deleted: given in Table 5

Table 5 - Material Classes for Structural Members of Polar Ships

Structural Members	Material Class
Shell plating within the bow and bow intermediate icebelt hull areas (B, B _{ii})	II
All weather and sea exposed SECONDARY and PRIMARY, as defined in Table 1 of UR S6.1, structural members outside 0.4L amidships	I
Plating materials for stem and stern frames, rudder horn, rudder, propeller nozzle, shaft brackets, ice skeg, ice knife and other appendages subject to ice impact loads	II
All inboard framing members attached to the weather and sea-exposed plating, including any contiguous inboard member within 600 mm of the plating	I
Weather-exposed plating and attached framing in cargo holds of ships which by nature of their trade have their cargo hold hatches open during cold weather operations	I
All weather and sea exposed SPECIAL, as defined in Table 1 of UR S6.1, structural members within 0.2L from FP	II

Deleted: ¶
I2.12.2 . Material classes specified in Table 1 of UR S6.1 are applicable to polar ships regardless of the ship's length. In addition, material classes for weather and sea exposed structural members and for members attached to the weather and sea exposed shell plating of polar ships are given in Table 5. Where the material classes in Table 5 and those in Table 1 of UR S6.1 differ, the higher material class is to be applied. ¶

Deleted: shell

Deleted: 1

Deleted: 2007

I2 (cont)

I2.12.2 Material classes specified in Table 1 of UR S6.1 are applicable to polar ships regardless of the ship's length. In addition, material classes for weather and sea exposed structural members and for members attached to the weather and sea exposed plating are given in Table 5. Where the material classes in Table 5 and those in Table 1 of UR S6.1 differ, the higher material class is to be applied.

I2.12.3 Steel grades for all plating and attached framing of hull structures and appendages situated below the level of 0.3 m below the lower waterline, as shown in Figure 6, are to be obtained from Table 6 of UR S6 based on the Material Class for Structural Members in Table 5 above, regardless of Polar Class.

Deleted: 2

Figure 6 - Steel Grade Requirements for Submerged and Weather Exposed Shell Plating

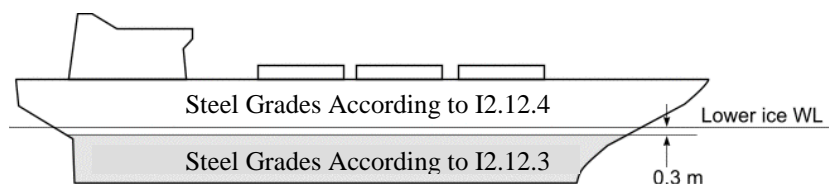

I2.12.4 Steel grades for all weather exposed plating of hull structures and appendages situated above the level of 0.3 m below the lower ice waterline, as shown in Figure 6, are to be not less than given in Table 6.

Table 6 - Steel Grades for Weather Exposed Plating

Thickness, t [mm]	Material Class I				Material Class II				Material Class III					
	PC1-5		PC6&7		PC1-5		PC6&7		PC1-3		PC4&5		PC6&7	
	MS	HT	MS	HT	MS	HT	MS	HT	MS	HT	MS	HT	MS	HT
$t \leq 10$	B	AH	B	AH	B	AH	B	AH	E	EH	E	EH	B	AH
$10 < t \leq 15$	B	AH	B	AH	D	DH	B	AH	E	EH	E	EH	D	DH
$15 < t \leq 20$	D	DH	B	AH	D	DH	B	AH	E	EH	E	EH	D	DH
$20 < t \leq 25$	D	DH	B	AH	D	DH	B	AH	E	EH	E	EH	D	DH
$25 < t \leq 30$	D	DH	B	AH	E	EH2	D	DH	E	EH	E	EH	E	EH
$30 < t \leq 35$	D	DH	B	AH	E	EH	D	DH	E	EH	E	EH	E	EH
$35 < t \leq 40$	D	DH	D	DH	E	EH	D	DH	F	FH	E	EH	E	EH
$40 < t \leq 45$	E	EH	D	DH	E	EH	D	DH	F	FH	E	EH	E	EH
$45 < t \leq 50$	E	EH	D	DH	E	EH	D	DH	F	FH	F	FH	E	EH

Notes to Table 6:

- 1) Includes weather-exposed plating of hull structures and appendages, as well as their outboard framing members, situated above a level of 0.3 m below the lowest ice waterline.
- 2) Grades D, DH are allowed for a single strake of side shell plating not more than 1.8 m wide from 0.3 m below the lowest ice waterline.

I2.12.5 Steel grades for all inboard framing members attached to weather exposed plating are to be not less than given in Table 7. This applies to all inboard framing members as well as

Deleted: 1

Deleted: 2007

to other contiguous inboard members (e.g. bulkheads, decks) within 600 mm of the exposed plating.

Table 7 - Steel Grades for Inboard Framing Members Attached to Weather Exposed Plating

Thickness t, mm	PC1 - PC5		PC6 & PC7	
	MS	HT	MS	HT
t ≤ 20	B	AH	B	AH
20 < t ≤ 35	D	DH	B	AH
35 < t ≤ 45	D	DH	D	DH
45 < t ≤ 50	E	EH	D	DH

I2.12.6 Castings are to have specified properties consistent with the expected service temperature for the cast component.

I2.13 Longitudinal Strength

I2.13.1 Application

I2.13.1.1 Ice loads need only be combined with still water loads. The combined stresses are to be compared against permissible bending and shear stresses at different locations along the ship's length. In addition, sufficient local buckling strength is also to be verified.

I2.13.2 Design Vertical Ice Force at the Bow

I2.13.2.1 The design vertical ice force at the bow, F_{IB} , is to be taken as

$F_{IB} = \text{minimum} (F_{IB,1}; F_{IB,2}) \text{ [MN]}$ [Equation 27]

where $F_{IB,1} = 0.534 \cdot K_I^{0.15} \cdot \sin^{0.2}(\gamma_{stem}) \cdot (D \cdot K_h)^{0.5} \cdot CF_L \text{ [MN]}$ [Equation 28]

$F_{IB,2} = 1.20 \cdot CF_F \text{ [MN]}$ [Equation 29]

K_I = indentation parameter = K_f / K_h

a) for the case of a blunt bow form

$K_f = (2 \cdot C \cdot B^{1-e_b} / (1 + e_b))^{0.9} \cdot \tan(\gamma_{stem})^{-0.9 \cdot (1 + e_b)}$

b) for the case of wedge bow form ($\alpha_{stem} < 80 \text{ deg}$), $e_b = 1$ and the above simplifies to

$K_f = (\tan(\alpha_{stem}) / \tan^2(\gamma_{stem}))^{0.9}$

$K_h = 0.01 \cdot A_{wp} \text{ [MN/m]}$

CF_L = Longitudinal Strength Class Factor from Table 1

e_b = bow shape exponent which best describes the waterplane (see Figures 7 and 8)

= 1.0 for a simple wedge bow form

= 0.4 to 0.6 for a spoon bow form

= 0 for a landing craft bow form

An approximate e_b determined by a simple fit is acceptable

γ_{stem} = stem angle to be measured between the horizontal axis and the stem tangent at the upper ice waterline [deg] (buttock angle as per Figure 2 measured on the centreline)

- Deleted: *
- Deleted: *
- Formatted: Not Superscript/ Subscript
- Deleted: *
- Deleted: *
- Deleted: *
- Deleted: *
- Formatted: English (U.K.)
- Deleted: *
- Deleted: *
- Deleted: *
- Deleted: *
- Formatted: German (Germany)
- Formatted: Norwegian (Bokmål)
- Formatted: Norwegian (Bokmål)
- Deleted:
- Formatted: Norwegian (Bokmål)
- Formatted: Norwegian (Bokmål)
- Deleted:
- Formatted: Norwegian (Bokmål)
- Deleted: *
- Deleted: 1
- Deleted: 2007

α_{stem} = waterline angle measured in way of the stem at the upper ice waterline (UIWL) [deg] (see Figure 7)

$C = 1 / (2 \cdot (L_B / B)^{e_b})$

B = ship moulded breadth [m]

L_B = bow length used in the equation $y = B / 2 \cdot (x/L_B)^{e_b}$ [m] (see Figures 7 and 8)

D = ship displacement [kt], not to be taken less than 10 kt

A_{wp} = ship waterplane area [m²]

CF_F = Flexural Failure Class Factor from Table 1

Where applicable, draught dependent quantities are to be determined at the waterline corresponding to the loading condition under consideration.

Formatted: Font: Symbol

Formatted: Subscript

Deleted: *

Deleted: *

Figure 7 - Bow Shape Definition

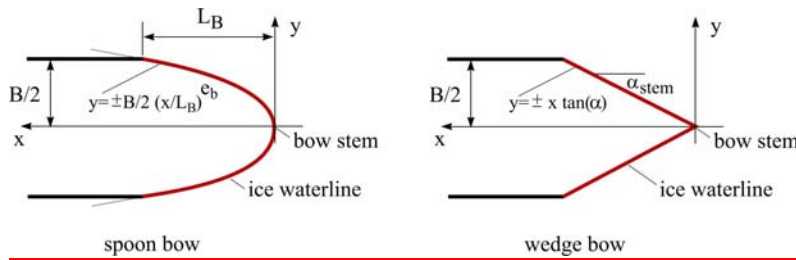

Formatted: Centered

Figure 8 - Illustration of e_b Effect on the Bow Shape for B = 20 and $L_B = 16$

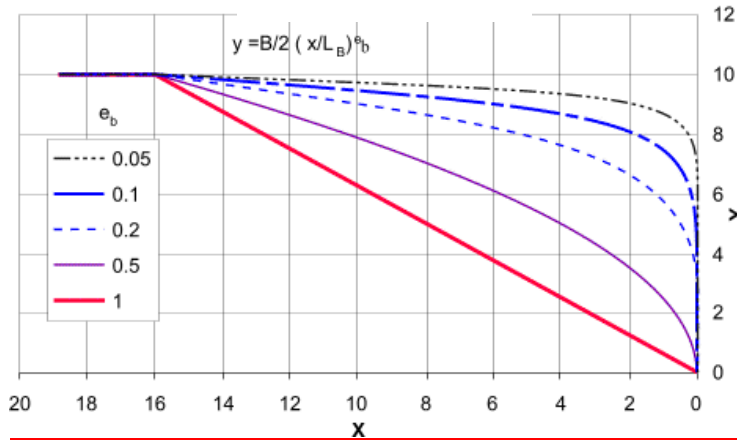

Formatted: Centered

I2.13.3 Design Vertical Shear Force

I2.13.3.1 The design vertical ice shear force, F_I , along the hull girder is to be taken as:

$F_I = C_f \cdot F_{IB}$ [MN] [Equation 30]

Deleted: *

where C_f = longitudinal distribution factor to be taken as follows:

- (a) Positive shear force
 - $C_f = 0.0$ between the aft end of L and 0.6L from aft
 - $C_f = 1.0$ between 0.9 L from aft and the forward end of L
- (b) Negative shear force

Deleted: 1

Deleted: 2007

I2
(cont)

$C_f = 0.0$ at the aft end of L
 $C_f = -0.5$ between 0.2 L and 0.6L from aft
 $C_f = 0.0$ between 0.8 L from aft and the forward end of L

Intermediate values are to be determined by linear interpolation

I2.13.3.2 The applied vertical shear stress, τ_a , is to be determined along the hull girder in a similar manner as in UR S11.5.4.2 by substituting the design vertical ice shear force for the design vertical wave shear force.

I2.13.4 Design Vertical Ice Bending Moment

I2.13.4.1 The design vertical ice bending moment, M_i , along the hull girder is to be taken as:

$M_i = 0.1 \cdot C_m \cdot L \cdot \sin^{0.2}(\gamma_{stem}) \cdot F_{IB}$ [MNm] [Equation 31]

where L = ship length as defined in UR S2.1, but measured on the upper ice waterline [UIWL] [m]

γ_{stem} is as given in I2.13.2.1

F_{IB} = design vertical ice force at the bow [MN]

C_m = longitudinal distribution factor for design vertical ice bending moment to be taken as follows:

$C_m = 0.0$ at the aft end of L

$C_m = 1.0$ between 0.5L and 0.7L from aft

$C_m = 0.3$ at 0.95L from aft

$C_m = 0.0$ at the forward end of L

Intermediate values are to be determined by linear interpolation

Where applicable, draught dependent quantities are to be determined at the waterline corresponding to the loading condition under consideration.

- Deleted: *
- Deleted: *
- Deleted: *
- Formatted: English (U.K.)
- Formatted: English (U.K.)
- Deleted: *
- Formatted: English (U.K.)
- Formatted: English (U.K.)
- Formatted: English (U.K.)
- Formatted: English (U.K.)
- Deleted: (Rule Length
- Deleted:)

I2.13.4.2 The applied vertical bending stress, σ_a , is to be determined along the hull girder in a similar manner as in UR S11.5.4.1, by substituting the design vertical ice bending moment for the design vertical wave bending moment. The ship still water bending moment is to be taken as the maximum sagging moment.

I2.13.5 Longitudinal Strength Criteria

I2.13.5.1 The strength criteria provided in Table 8 are to be satisfied. The design stress is not to exceed the permissible stress.

Table 8 - Longitudinal Strength Criteria

Failure Mode	Applied Stress	Permissible Stress when $\sigma_y / \sigma_u \leq 0.7$	Permissible Stress when $\sigma_y / \sigma_u > 0.7$
Tension	σ_a	$\eta \cdot \sigma_y$	$\eta \cdot 0.41 (\sigma_u + \sigma_y)$
Shear	τ_a	$\eta \cdot \sigma_y / (3)^{0.5}$	$\eta \cdot 0.41 (\sigma_u + \sigma_y) / (3)^{0.5}$
Buckling	σ_a	σ_c for plating and for web plating of stiffeners $\sigma_c / 1.1$ for stiffeners	
	τ_a	τ_c	

- Deleted: *
- Deleted: *
- Deleted: *
- Deleted: *

where σ_a = applied vertical bending stress [N/mm²]
 τ_a = applied vertical shear stress [N/mm²]

- Deleted: 1
- Deleted: 2007

I2 (cont)

σ_y = minimum upper yield stress of the material [N/mm²]
 σ_u = ultimate tensile strength of material [N/mm²]
 σ_c = critical buckling stress in compression, according to UR S11.5 [N/mm²]
 τ_c = critical buckling stress in shear, according to UR S11.5 [N/mm²]
 $\eta = 0.8$

I2.14 Stem and Stern Frames

I2.14.1 The stem and stern frame are to be designed according to the requirements of each member society. For PC6/PC7 vessels requiring 1AS/1A equivalency, the stem and stern requirements of the Finnish-Swedish Ice Class Rules may need to be additionally considered.

I2.15 Appendages

I2.15.1 All appendages are to be designed to withstand forces appropriate for the location of their attachment to the hull structure or their position within a hull area.

I2.15.2 Load definition and response criteria are to be determined by each member society.

I2.16 Local Details

I2.16.1 For the purpose of transferring ice-induced loads to supporting structure (bending moments and shear forces), local design details are to comply with the requirements of each member society.

I2.16.2 The loads carried by a member in way of cut-outs are not to cause instability. Where necessary, the structure is to be stiffened.

I2.17 Direct Calculations

I2.17.1 Direct calculations are not to be utilised as an alternative to the analytical procedures prescribed in this unified requirement.

I2.17.2 Where direct calculation is used to check the strength of structural systems, the load patch specified in I2.3 is to be applied.

I2.18 Welding

I2.18.1 All welding within ice-strengthened areas is to be of the double continuous type.

I2.18.2 Continuity of strength is to be ensured at all structural connections.

End of Document

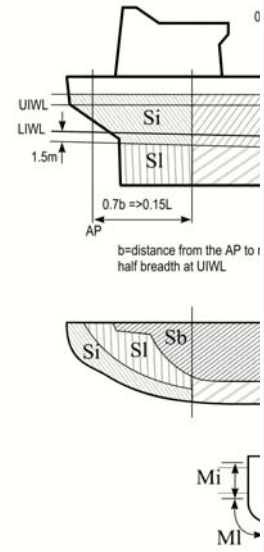
Deleted: ¶
 ¶
 Figure 1 - Hull Area Extents¶
 ¶
 <sp>
 EXTENT OF HU

 ¶
 ¶
 Page Break
 ¶
 Figure 2 - Definition of Hull
 Angles¶
 ¶
 <sp>
 ¶
 ¶
 Note: . β' = normal frame angle
 at upper ice waterline [deg]¶
 . α = upper ice waterline
 angle [deg]¶
 . γ = buttock angle at upper
 ice waterline (angle of buttock
 line measured from horizontal)
 [deg]¶
 . $\tan(\beta) = \tan(\alpha)/\tan(\gamma)$ [2]
 ¶
 Formatted: Finnish
 Deleted: ¶
 ¶
 ¶
 Formatted: Finnish
 Formatted: Finnish
 Formatted: Finnish
 Deleted: 1
 Deleted: 2007

Page 14: [1] Deleted	hay2			17/12/2009 16:47:00		
Other Areas	2.0	2.0	2.0	3.5	2.5	2.0
Page 19: [2] Deleted	hay2			28/01/2010 16:12:00		

Figure 1 - Hull Area Extents

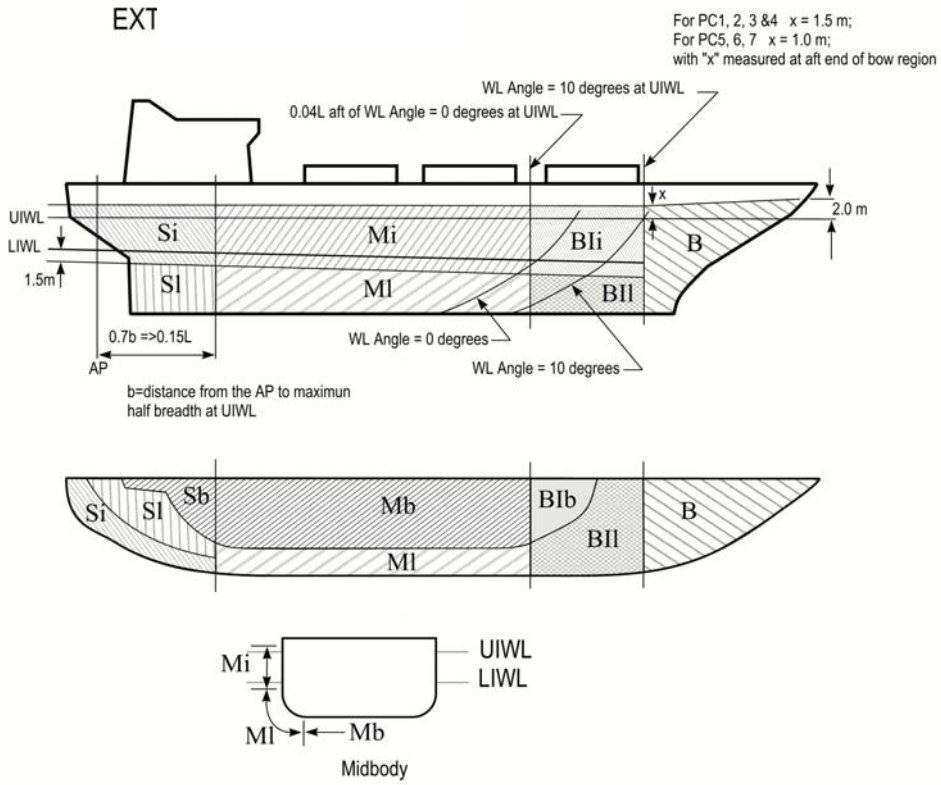
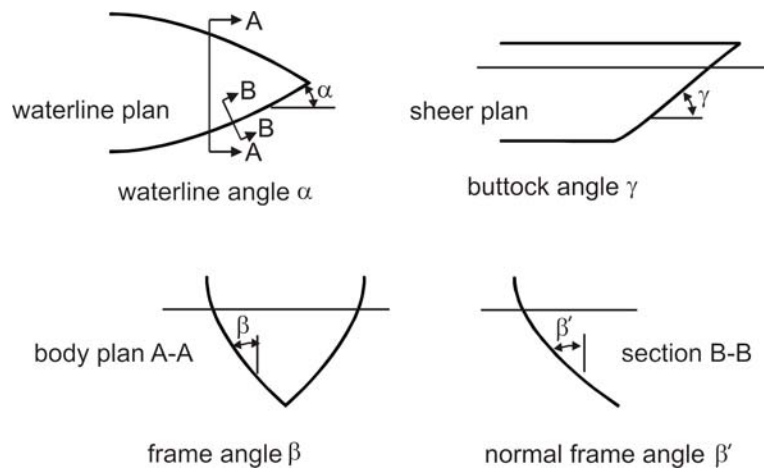

Figure 2 - Definition of Hull Angles



Note: β' = normal frame angle at upper ice waterline [deg]
 α = upper ice waterline angle [deg]
 γ = buttock angle at upper ice waterline (angle of buttock line measured from horizontal) [deg]
 $\tan(\beta) = \tan(\alpha)/\tan(\gamma)$
 $\tan(\beta') = \tan(\beta) \cos(\alpha)$

Figure 3 - Shell Framing Angle Ω

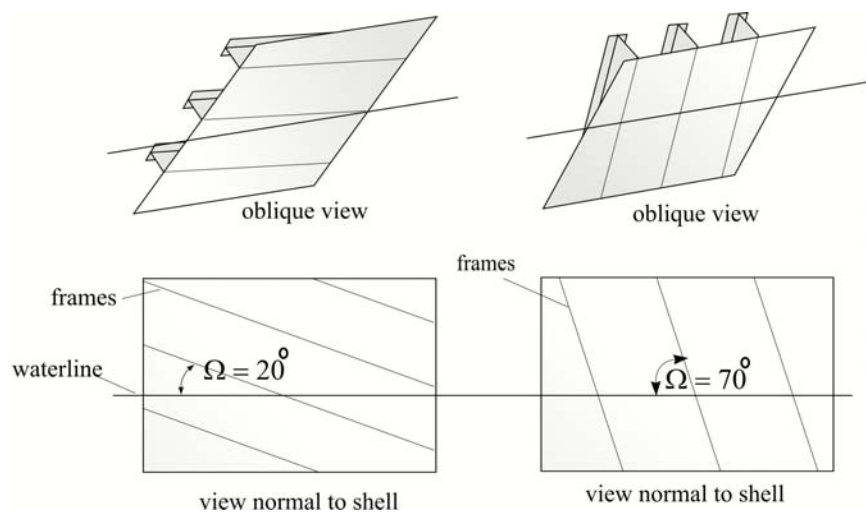

Figure 4 - Stiffener geometry

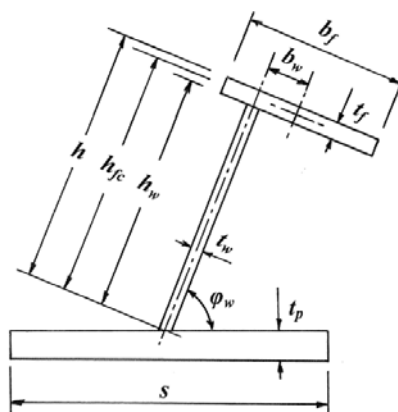

Figure 5 - Parameter Definition for Web Stiffening

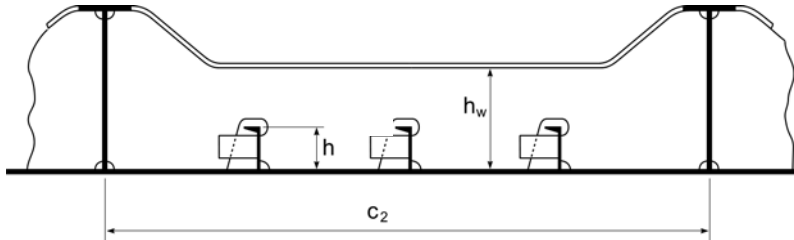

Figure 6 - Steel Grade Requirements for Submerged and Weather Exposed Shell Plating

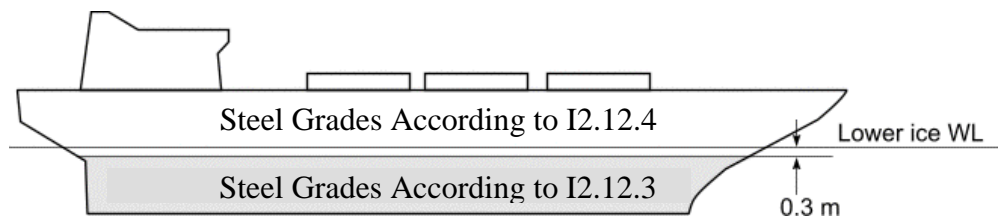

Figure 7 - Bow Shape Definition

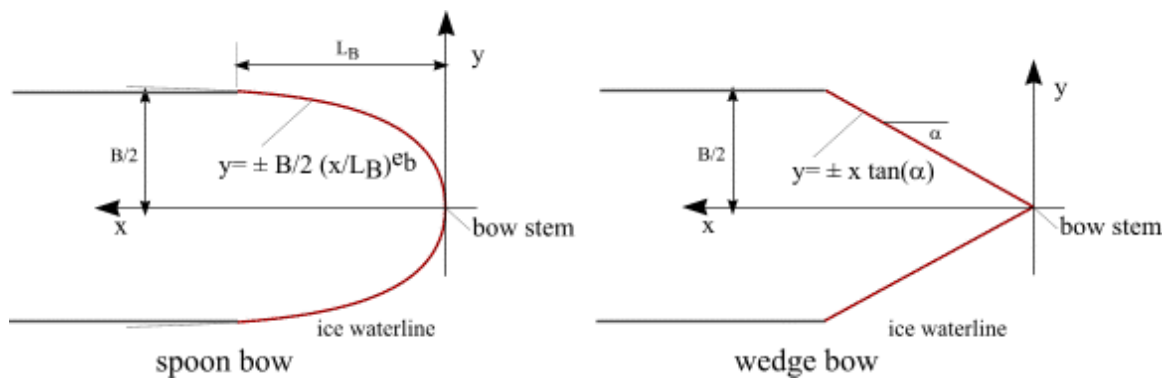

Figure 8 - Illustration of e_b Effect on the Bow Shape for $B = 20$ and $L_B = 16$

