

ANNEX 13

**RESOLUTION MEPC.411(84)
(adopted on 1 May 2026)**

**2026 GUIDELINES ON SURVEY AND CERTIFICATION OF THE ENERGY EFFICIENCY
DESIGN INDEX (EEDI)**

THE MARINE ENVIRONMENT PROTECTION COMMITTEE,

RECALLING Article 38(a) of the Convention on the International Maritime Organization concerning the functions of the Marine Environment Protection Committee conferred upon it by international conventions for the prevention and control of marine pollution from ships,

NOTING that regulation 5 (Surveys) of MARPOL Annex VI, as amended, requires that ships to which chapter 4 of that Annex applies shall also be subject to survey and certification taking into account guidelines developed by the Organization,

RECALLING that, at its seventy-ninth session, it adopted, by resolution MEPC.365(79), the *2022 Guidelines on survey and certification of the Energy Efficiency Design Index (EEDI)*,

RECALLING ALSO that, at its eightieth session, it adopted, by resolution MEPC.374(80), amendments to the *2022 Guidelines on survey and certification of the Energy Efficiency Design Index (EEDI)*,

RECALLING FURTHER that, at its eighty-third session, it adopted, by resolution MEPC.403(83), amendments to the *2022 Guidelines on survey and certification of the Energy Efficiency Design Index (EEDI)*,

HAVING CONSIDERED, at its eighty-fourth session, draft amendments to the *2022 Guidelines on survey and certification of the Energy Efficiency Design Index (EEDI)*, as amended,

1 ADOPTS the *2026 Guidelines on survey and certification of the Energy Efficiency Design Index (EEDI)* (2026 EEDI Survey and Certification Guidelines), as set out in the annex to the present resolution;

2 INVITES Administrations to implement the 2026 EEDI Survey and Certification Guidelines when developing and enacting national laws which give force to and implement provisions set forth in regulation 5 of MARPOL Annex VI, as amended;

3 REQUESTS the Parties to MARPOL Annex VI and other Member Governments to bring the annexed Guidelines to the attention of shipowners, ship operators, shipbuilders, ship designers and any other interested groups;

4 AGREES to keep these Guidelines, as amended, under review, in light of the experience gained with their application;

5 AGREES that these Guidelines supersede the *2022 Guidelines on survey and certification of the Energy Efficiency Design Index (EEDI)* (resolution MEPC.365(79), as amended by resolutions MEPC.374(80) and MEPC.403(83)).

ANNEX

**2026 GUIDELINES ON SURVEY AND CERTIFICATION OF
THE ENERGY EFFICIENCY DESIGN INDEX (EEDI)**

Table of contents

1	GENERAL
2	DEFINITIONS
3	APPLICATION
4	PROCEDURES FOR SURVEY AND CERTIFICATION
4.1	General
4.2	Preliminary verification of the attained EEDI at the design stage
4.3	Final verification of the attained EEDI at sea trial
4.4	Verification of the attained EEDI in case of major conversion
Appendix 1	Sample of EEDI Technical File
Appendix 2	Guidelines for validation of electric power tables for EEDI (EPT-EEDI)
Appendix 3	Electric power table form for EEDI (EPT-EEDI Form) and statement of validation

1 GENERAL

The purpose of these guidelines is to assist verifiers of the Energy Efficiency Design Index (EEDI) of ships in conducting the survey and certification of the EEDI, in accordance with regulations 5, 6, 7, 8 and 9 of MARPOL Annex VI, and assist shipowners, shipbuilders, manufacturers and other interested parties in understanding the procedures for the survey and certification of the EEDI.

2 DEFINITIONS¹

2.1 *Verifier* means an Administration or organization duly authorized by it which conducts the survey and certification of the EEDI in accordance with regulations 5, 6, 7, 8 and 9 of MARPOL Annex VI and these guidelines.

2.2 *Ship of the same type* means a ship the hull form (expressed in the lines such as sheer plan and body plan), excluding additional hull features such as fins, and principal particulars of which are identical to that of the base ship.

2.3 *Tank test* means model towing tests, model self-propulsion tests and model propeller open water tests. Numerical calculations may be accepted as equivalent to model propeller open water tests or used to complement the tank tests conducted (e.g. to evaluate the effect of additional hull features such as fins, etc. on ship's performance), with the approval of the verifier.

3 APPLICATION

These guidelines should be applied to new ships for which an application for an initial survey or an additional survey specified in regulation 5 of MARPOL Annex VI has been submitted to a verifier.

4 PROCEDURES FOR SURVEY AND CERTIFICATION

4.1 General

4.1.1 The attained EEDI should be calculated in accordance with regulation 22 of MARPOL Annex VI and the *2022 Guidelines on the method of calculation of the attained Energy Efficiency Design Index (EEDI) for new ships* (resolution MEPC.364(79), as amended) (EEDI Calculation Guidelines). Survey and certification of the EEDI should be conducted in two stages: preliminary verification at the design stage and final verification at the sea trial. The basic flow of the survey and certification process is presented in figure 1.

4.1.2 The information used in the verification process may contain confidential information of submitters which requires Intellectual Property Rights (IPR) protection. In the case where the submitter wants a non-disclosure agreement with the verifier, the additional information should be provided to the verifier upon mutually agreed terms and conditions.

¹ Other terms used in these guidelines have the same meaning as those defined in the *2022 Guidelines on the method of calculation of the attained EEDI for new ships* (resolution MEPC.364(79), as amended).

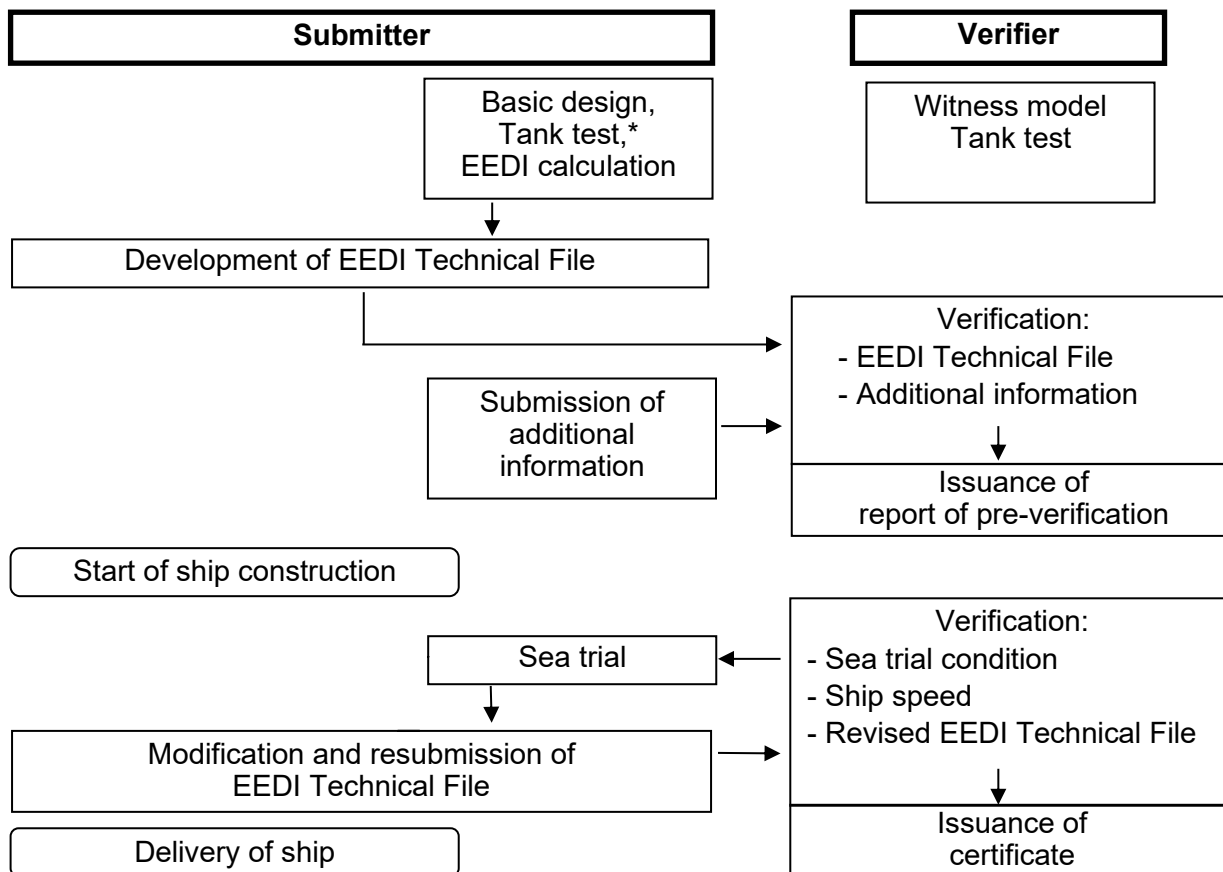

* To be conducted by a test organization or a submitter.

Figure 1: Basic flow of survey and certification process

4.2 Preliminary verification of the attained EEDI at the design stage

4.2.1 For the preliminary verification at the design stage, an application for an initial survey and an EEDI Technical File containing the necessary information for the verification and other relevant background documents should be submitted to a verifier.

4.2.2 The EEDI Technical File should be written at least in English. The EEDI Technical File should include as a minimum, but not be limited to:

- .1 deadweight (DWT) or gross tonnage (GT) for passenger and ro-ro passenger ships, the maximum continuous rating (MCR) of the main and auxiliary engines, the ship speed (V_{ref}), as specified in paragraph 2.2.2 of the EEDI Calculation Guidelines, type of fuel, the specific fuel consumption (SFC) of the main engine at 75% of MCR power, the SFC of the auxiliary engines at 50% MCR power, and the electric power table² for certain ship types, as necessary, as defined in the EEDI Calculation Guidelines;

² Electric power table should be validated separately, taking into account guidelines set out in appendix 2 to these Guidelines.

- .2 power curve(s) (kW – knot) estimated at design stage under the condition as specified in paragraph 2.2.2 of the EEDI Calculation Guidelines, and, in the event that the sea trial is carried out in a condition other than the above condition, also a power curve estimated under the sea trial condition;
- .3 principal particulars, ship type and the relevant information to classify the ship as such a ship type, classification notations and an overview of the propulsion system and electricity supply system on board;
- .4 estimation process and methodology of the power curves at design stage;
- .5 description of energy-saving equipment;
- .6 calculated value of the attained EEDI, including the calculation summary, which should contain, at a minimum, each value of the calculation parameters and the calculation process used to determine the attained EEDI;
- .7 calculated values of the attained $EEDI_{weather}$ and f_w value (not equal to 1.0), if those values are calculated, based on the EEDI Calculation Guidelines; and
- .8 for LNG carriers:
 - .1 type and outline of propulsion systems (such as direct drive diesel, diesel electric, steam turbine);
 - .2 LNG cargo tank capacity in m^3 and BOR as defined in paragraph 2.2.5.6.3 of the EEDI Calculation Guidelines;
 - .3 shaft power of the propeller shaft after transmission gear at 100% of the rated output of motor (MPP_{Motor}) and $\eta_{(i)}$ for diesel electric;
 - .4 maximum continuous rated power ($MCR_{SteamTurbine}$) for steam turbine; and
 - .5 $SFC_{SteamTurbine}$ for steam turbine, as specified in paragraph 2.2.7 of the EEDI Calculation Guidelines.

A sample of an EEDI Technical File is provided in appendix 1 to these guidelines.

4.2.3 For ships equipped with dual-fuel engine(s) using LNG and fuel oil, the C_F factor for gas (LNG) and the specific fuel consumption (SFC) of gas fuel should be used by applying the following criteria as a basis for the guidance of the Administration:³

- .1 final decision on the primary fuel rests with the Administration;
- .2 the ratio of calorific value of gas fuel (LNG) to total marine fuels (HFO/MGO), including gas fuel (LNG) at design conditions should be equal or larger than 50% in accordance with the formula below. However, the Administration can accept a lower value of the percentage taking into account the intended voyages:

³ For the purpose of this paragraph, the terms "LNG" and "gas" may be taken to include any fuel used in dual-fuel mode including liquid fuels.

$$\frac{V_{gas} \times \rho_{gas} \times LCV_{gas} \times K_{gas}}{\left(\sum_{i=1}^{nLiquid} V_{liquid(i)} \times \rho_{liquid(i)} \times LCV_{liquid(i)} \times K_{liquid(i)} \right) + V_{gas} \times \rho_{gas} \times LCV_{gas} \times K_{gas}} \geq 50\%$$

Whereby,

V_{gas} is the total net tank volume of gas fuel on board in m³;

V_{liquid} is the total net tank volume of every liquid fuel on board in m³;

ρ_{gas} is the density of gas fuel in kg/m³;

ρ_{liquid} is the density of every liquid fuel in kg/m³;

LCV_{gas} is the low calorific value of gas fuel in kJ/kg;

LCV_{liquid} is the low calorific value of liquid fuel in kJ/kg;

K_{gas} is the filling rate for gas fuel tanks;

K_{liquid} is the filling rate for liquid fuel tanks.

Normal density, Low Calorific Value and filling rate for tanks of different kinds of fuel are listed below.

Type of fuel	Density (kg/m ³)	Low Calorific Value (kJ/kg)	Filling rate for tanks
Diesel/Gas Oil	900	42,700	0.98
Heavy Fuel Oil	991	40,200	0.98
Liquefied Natural Gas (LNG)	450	48,000	0.95*

* Subject to verification of tank loading limit in the IGF and/or IGC Codes, where applicable, corresponding to the normal density used in the calculation of f_{DFgas}

Note: In case of other fuels, the low calorific value should be taken from the 2022 EEDI Calculation Guidelines (resolution MEPC.364(79), as amended), where available. If not listed, values consistent with industry standards should be applied. Density values should correspond to industry standards. Filling rate for tanks values should reflect the applicable design specifications.

- .3 in case the ship is not fully equipped with dual-fuel engines, the C_F factor for gas (LNG) should apply only for those installed engines that are of dual-fuel type and sufficient gas fuel supply should be available for such engines; and
- .4 LNG fuelling solutions with exchangeable (specialized) LNG tank-containers should also fall under the terms of LNG as primary fuel.

4.2.4 The *SFC* of the main and auxiliary engines should be quoted from the approved NO_x Technical File and should be corrected to the value corresponding to the ISO standard reference conditions using the standard lower calorific value of the fuel oil (42,700 kJ/kg), referring to ISO 15550:2002 and ISO 3046-1:2002. For the confirmation of the *SFC*, a copy of the approved NO_x Technical File and documented summary of the correction calculations

should be submitted to the verifier. In cases where the NO_x Technical File has not been approved at the time of the application for initial survey, the test reports provided by manufacturers should be used. In this case, at the time of the sea trial verification, a copy of the approved NO_x Technical File and documented summary of the correction calculations should be submitted to the verifier. In the case that gas fuel is determined as primary fuel in accordance with paragraph 4.2.3 and that installed engine(s) have no approved NO_x Technical File tested in gas mode, the *SFC* of gas mode should be submitted by the manufacturer and confirmed by the verifier.

Note: *SFC* in the NO_x Technical File are the values of a parent engine, and the use of such value of *SFC* for the EEDI calculation for member engines may have the following technical issues for further consideration:

- .1 the definition of "member engines" given in the NO_x Technical File is broad and specification of engines belonging to the same group/family may vary; and
- .2 the rate of NO_x emission of the parent engine is the highest in the group/family – i.e. CO₂ emission, which is in the trade-off relationship with NO_x emission, can be lower than the other engines in the group/family.

4.2.5 For ships to which regulation 24 of MARPOL Annex VI applies, the power curves used for the preliminary verification at the design stage should be based on reliable results of tank tests. A tank test for an individual ship may be omitted based on technical justifications such as availability of the results of tank tests for ships of the same type. In addition, the omission of tank tests is acceptable for a ship for which sea trials will be carried out under the condition as specified in paragraph 2.2.2 of the EEDI Calculation Guidelines, upon agreement of the shipowner and shipbuilder and with the approval of the verifier. To ensure the quality of tank tests, the ITTC quality system should be taken into account. Model tank tests should be witnessed by the verifier.

Note: It would be desirable in the future that an organization conducting a tank test be authorized.

4.2.6 The verifier may request further information from the submitter, in addition to that contained in the EEDI Technical File, as necessary, to examine the calculation process of the attained EEDI. For the estimation of the ship speed at the design stage much depends on each shipbuilder's experience, and it may not be practicable for any person/organization other than the shipbuilder to fully examine the technical aspects of experience-based parameters, such as the roughness coefficient and wake scaling coefficient. Therefore, the preliminary verification should focus on the calculation process of the attained EEDI to ensure that it is technically sound and reasonable and follows regulation 22 of MARPOL Annex VI and the EEDI Calculation Guidelines.

Note 1: A possible way forward for more robust verification is to establish a standard methodology of deriving the ship speed from the outcome of tank tests, by setting standard values for experience-based correction factors such as roughness coefficient and wake scaling coefficient. In this way, ship-by-ship performance comparisons could be made more objectively by excluding the possibility of arbitrary setting of experience-based parameters. If such standardization is sought, this would have an implication on how the ship speed adjustment based on sea trial results should be conducted, in accordance with paragraph 4.3.8 of these guidelines.

Note 2: A joint industry standard to support the method and role of the verifier is expected to be developed.

4.2.7 Additional information that the verifier may request the submitter to provide includes, but is not limited to:

- .1 descriptions of a tank test facility; this should include the name of the facility, the particulars of tanks and towing equipment, and the records of calibration of each monitoring equipment;
- .2 lines of a model ship and an actual ship for the verification of the appropriateness of the tank test; the lines (sheer plan, body plan and half-breadth plan) should be detailed enough to demonstrate the similarity between the model ship and the actual ship;
- .3 lightweight of the ship and displacement table for the verification of the deadweight;
- .4 detailed report on the method and results of the tank test; this should include at least the tank test results at sea trial condition and under the condition as specified in paragraph 2.2.2 of the EEDI Calculation Guidelines;
- .5 detailed calculation process of the ship speed, which should include the basis for the estimation of experience-based parameters such as roughness coefficient, and wake scaling coefficient;
- .6 reasons for exempting a tank test, if applicable; this should include lines and tank test results of ships of the same type, and the comparison of the principal particulars of such ships and the ship in question. Appropriate technical justification should be provided, explaining why the tank test is unnecessary; and
- .7 for LNG carriers, detailed calculation process of P_{AE} and $SFC_{SteamTurbine}$.

4.2.8 The verifier should issue the report on the Preliminary Verification of the EEDI after it has verified the attained EEDI at the design stage, in accordance with paragraphs 4.1 and 4.2 of these guidelines.

4.3 Final verification of the attained EEDI at sea trial

4.3.1 Sea trial conditions should be set as the conditions specified in paragraph 2.2.2 of the EEDI Calculation Guidelines, if possible.

4.3.2 Prior to the sea trial, the following documents should be submitted to the verifier: a description of the test procedure to be used for the speed trial, the final displacement table and the measured lightweight, or a copy of the survey report of deadweight, as well as a copy of the NO_x Technical File, as necessary. The test procedure should include, as a minimum, descriptions of all necessary items to be measured and corresponding measurement methods to be used for developing power curves under the sea trial condition.

4.3.3 The verifier should attend the sea trial and confirm:

- .1 propulsion and power supply system, particulars of the engines or steam turbines, and other relevant items described in the EEDI Technical File;
- .2 draught and trim;
- .3 sea conditions;

- .4 ship speed; and
- .5 shaft power and RPM.

4.3.4 Draught and trim should be confirmed by the draught measurements taken prior to the sea trial. The draught and trim should be as close as practical to those at the assumed conditions used for estimating the power curves.

4.3.5 Sea conditions should be measured in accordance with ITTC Recommended Procedure 7.5-04-01-01.1 *Preparation, Conduct and Analysis of Speed/Power Trials 2024* or ISO 15016:2025.⁴

4.3.6 Ship speed should be measured in accordance with ITTC Recommended Procedure 7.5-04-01-01.1 *Preparation, Conduct and Analysis of Speed/Power Trials 2024* or ISO 15016:2025,⁴ and at more than two points of which range includes the power of the main engine as specified in paragraph 2.2.5 of the EEDI Calculation Guidelines.

4.3.7 The main engine output, shaft power of propeller shaft (for LNG carriers having diesel electric propulsion system) or steam turbine output (for LNG carriers having steam turbine propulsion system) should be measured by shaft power meter or a method which the engine manufacturer recommends and the verifier approves. Other methods may be acceptable upon agreement of the shipowner and shipbuilder and with the approval of the verifier.

4.3.8 The submitter should develop power curves based on the measured ship speed and the measured output of the main engine at sea trial. For the development of the power curves, the submitter should calibrate the measured ship speed, if necessary, by taking into account the effects of wind, current, waves, shallow water, displacement, water temperature and water density in accordance with ITTC Recommended Procedure 7.5-04-01-01.1 *Preparation, Conduct and Analysis of Speed/Power Trials 2024* or ISO 15016:2025.⁴ Upon agreement with the shipowner, the submitter should submit a report on the speed trials including details of the power curve development to the verifier for verification.

4.3.9 The submitter should compare the power curves obtained as a result of the sea trial and the estimated power curves at the design stage. In case differences are observed, the attained EEDI should be recalculated, as necessary, in accordance with the following:

- .1 for ships for which sea trial is conducted under the condition as specified in paragraph 2.2.2 of the EEDI Calculation Guidelines: the attained EEDI should be recalculated using the measured ship speed at sea trial at the power of the main engine as specified in paragraph 2.2.5 of the EEDI Calculation Guidelines; and
- .2 for ships for which sea trial cannot be conducted under the condition as specified in paragraph 2.2.2 of the EEDI Calculation Guidelines: if the measured ship speed at the power of the main engine as specified in paragraph 2.2.5 of the EEDI Calculation Guidelines at the sea trial conditions is different from the expected ship speed on the power curve at the corresponding condition, the shipbuilder should recalculate the attained EEDI by adjusting ship speed under the condition as specified in paragraph 2.2.2 of the EEDI Calculation Guidelines by an appropriate correction method that is agreed by the verifier.

⁴ Until 1 May 2026, ISO 15016:2015 may also be used.

An example of scheme of conversion from trial condition to EEDI condition at EEDI power is given as follows:

V_{ref} is obtained from the results of the sea trials at trial condition using the speed-power curves predicted by the tank tests. The tank tests shall be carried out at both draughts: trial condition corresponding to that of the S/P trials and EEDI condition. For trial conditions the power ratio α_P between model test prediction and sea trial result is calculated for constant ship speed. Ship speed from model test prediction for EEDI condition at EEDI power multiplied with α_P is V_{ref} .

$$\alpha_P = \frac{P_{Trial,P}}{P_{Trial,S}}$$

where:

$P_{Trial,P}$: power at trial condition predicted by the tank tests

$P_{Trial,S}$: power at trial condition obtained by the S/P trials

α_P : power ratio

Figure 2 shows an example of scheme of the conversion to derive the resulting ship speed at EEDI condition (V_{ref}) at EEDI power.

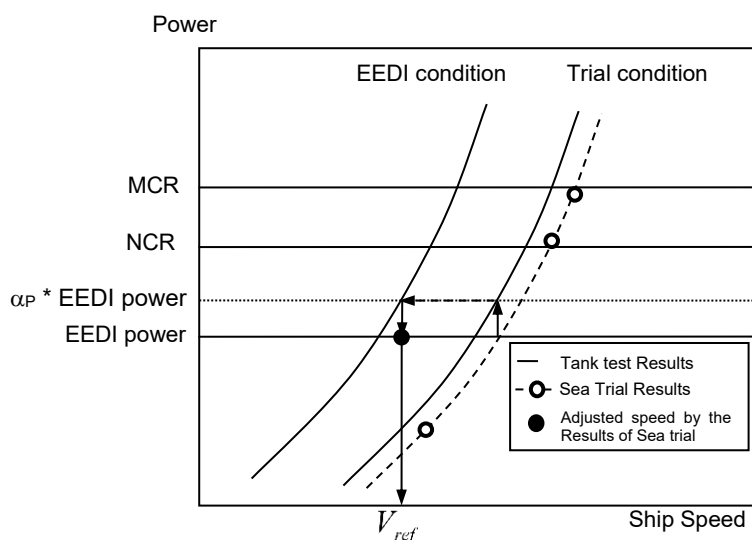

Figure 2: An example of scheme of conversion from trial condition to EEDI condition at EEDI power

Note: Further consideration would be necessary for speed adjustment methodology in paragraph 4.3.9.2 of these guidelines. One of the concerns relates to a possible situation where the power curve for sea trial condition is estimated in an excessively conservative manner (i.e. power curve is shifted in a leftward direction) with the intention to get an upward adjustment of the ship speed by making the measured ship speed at sea trial easily exceed the lower-estimated speed for sea trial condition at design stage.

4.3.10 In cases where the finally determined deadweight/gross tonnage differs from the designed deadweight/gross tonnage used in the EEDI calculation during the preliminary verification, the submitter should recalculate the attained EEDI using the finally determined deadweight/gross tonnage. The finally determined gross tonnage should be confirmed in the Tonnage Certificate of the ship.

4.3.11 The electrical efficiency $\eta_{(i)}$ should be taken as 91.3% for the purpose of calculating the attained EEDI. Alternatively, if a value of more than 91.3% is to be applied, $\eta_{(i)}$ should be obtained by measurement and verified by a method approved by the verifier.

4.3.12 In cases where the attained EEDI is calculated at the preliminary verification by using *SFC* based on the manufacturer's test report, owing to the non-availability at that time of the approved NO_x Technical File, the EEDI should be recalculated by using *SFC* in the approved NO_x Technical File. Also, for steam turbines, the EEDI should be recalculated by using *SFC* confirmed by the Administration or an organization recognized by the Administration at the sea trial.

4.3.13 The EEDI Technical File should be revised, as necessary, by taking into account the results of sea trials. Such revision should include, as applicable, the adjusted power curve based on the results of sea trials (namely, modified ship speed under the condition as specified in paragraph 2.2.2 of the EEDI Calculation Guidelines), the finally determined deadweight/gross tonnage, η for LNG carriers having diesel electric propulsion system and *SFC* described in the approved NO_x Technical File, and the recalculated attained EEDI based on these modifications.

4.3.14 The EEDI Technical File, if revised, should be submitted to the verifier for confirmation that the (revised) attained EEDI is calculated in accordance with regulation 22 of MARPOL Annex VI and the EEDI Calculation Guidelines.

4.4 Verification of the attained EEDI in case of major conversion

4.4.1 In cases of a major conversion of a ship, the shipowner should submit to a verifier an application for an Additional Survey with the EEDI Technical File duly revised, based on the conversion made and other relevant background documents.

4.4.2 The background documents should include as a minimum, but are not limited to:

- .1 details of the conversion;
- .2 EEDI parameters changed after the conversion and the technical justifications for each respective parameter;
- .3 reasons for other changes made in the EEDI Technical File, if any; and
- .4 calculated value of the attained EEDI with the calculation summary, which should contain, as a minimum, each value of the calculation parameters and the calculation process used to determine the attained EEDI after the conversion.

4.4.3 The verifier should review the revised EEDI Technical File and other documents submitted and verify the calculation process of the attained EEDI to ensure that it is technically sound and reasonable and follows regulation 22 of MARPOL Annex VI and the EEDI Calculation Guidelines.

4.4.4 For verification of the attained EEDI after a conversion, speed trials of the ship are required, as necessary.

APPENDIX 1

SAMPLE OF EEDI TECHNICAL FILE

1 Data

1.1 General information

Shipbuilder	JAPAN Shipbuilding Company
Hull no.	12345
IMO no.	941111XX
Ship type	Bulk carrier

1.2 Principal particulars

Length overall	250.0 m
Length between perpendiculars	240.0 m
Breadth, moulded	40.0 m
Depth, moulded	20.0 m
Summer load line draught, moulded	14.0 m
Deadweight at summer load line draught	150,000 tons

1.3 Main engine

Manufacturer	JAPAN Heavy Industries Ltd.
Type	6J70A
Maximum continuous rating (MCR)	15,000 kW x 80 rpm
SFC at 75% MCR	165.0 g/kWh
Number of set	1
Fuel type	Diesel Oil

1.4 Auxiliary engine

Manufacturer	JAPAN Diesel Ltd.
Type	5J-200
Maximum continuous rating (MCR)	600 kW x 900 rpm
SFC at 50% MCR	220.0 g/kWh
Number of set	3
Fuel type	Diesel Oil

1.5 Ship speed

Ship speed in deep water at summer load line draught at 75% of MCR	14.25 knots
--	-------------

2 Power curves

The power curves estimated at the design stage and modified after the speed trials are shown in figure 2.1.

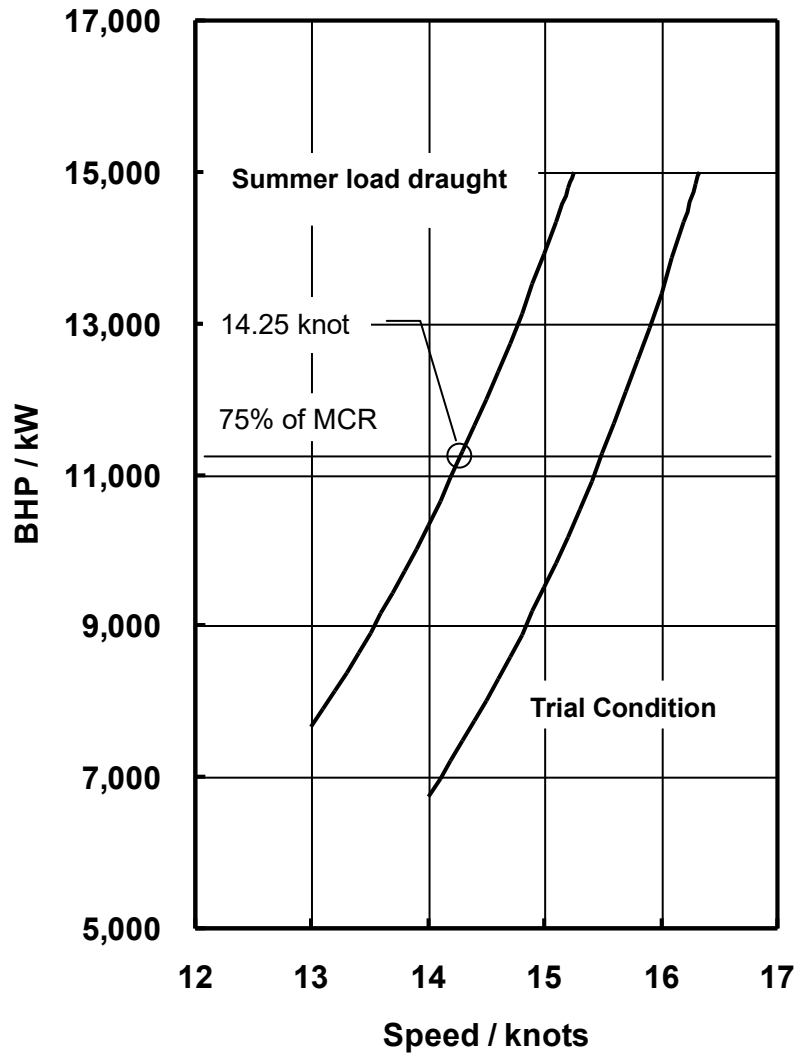

Figure 2.1: Power curves

3 Overview of propulsion system and electric power supply system

3.1 Propulsion system

3.1.1 Main engine
Refer to paragraph 1.3 of this appendix.

3.1.2 Propeller

Type	Fixed pitch propeller
Diameter	7.0 m
Number of blades	4
Number of set	1

3.2 Electric power supply system

3.2.1 Auxiliary engines
Refer to paragraph 1.4 of this appendix.

3.2.2 Main generators

Manufacturer	JAPAN Electric
Rated output	560 kW (700 kVA) x 900 rpm
Voltage	AC 450 V
Number of set	3

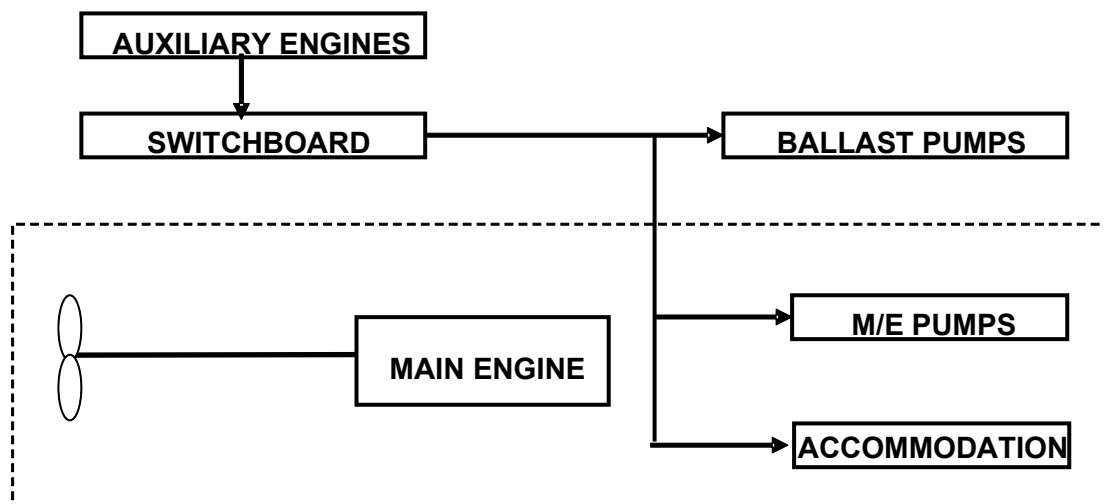

Figure 3.1: Schematic figure of propulsion and electric power supply system

4 Estimation process of power curves at design stage

Power curves are estimated based on model test results. The flow of the estimation process is shown below.

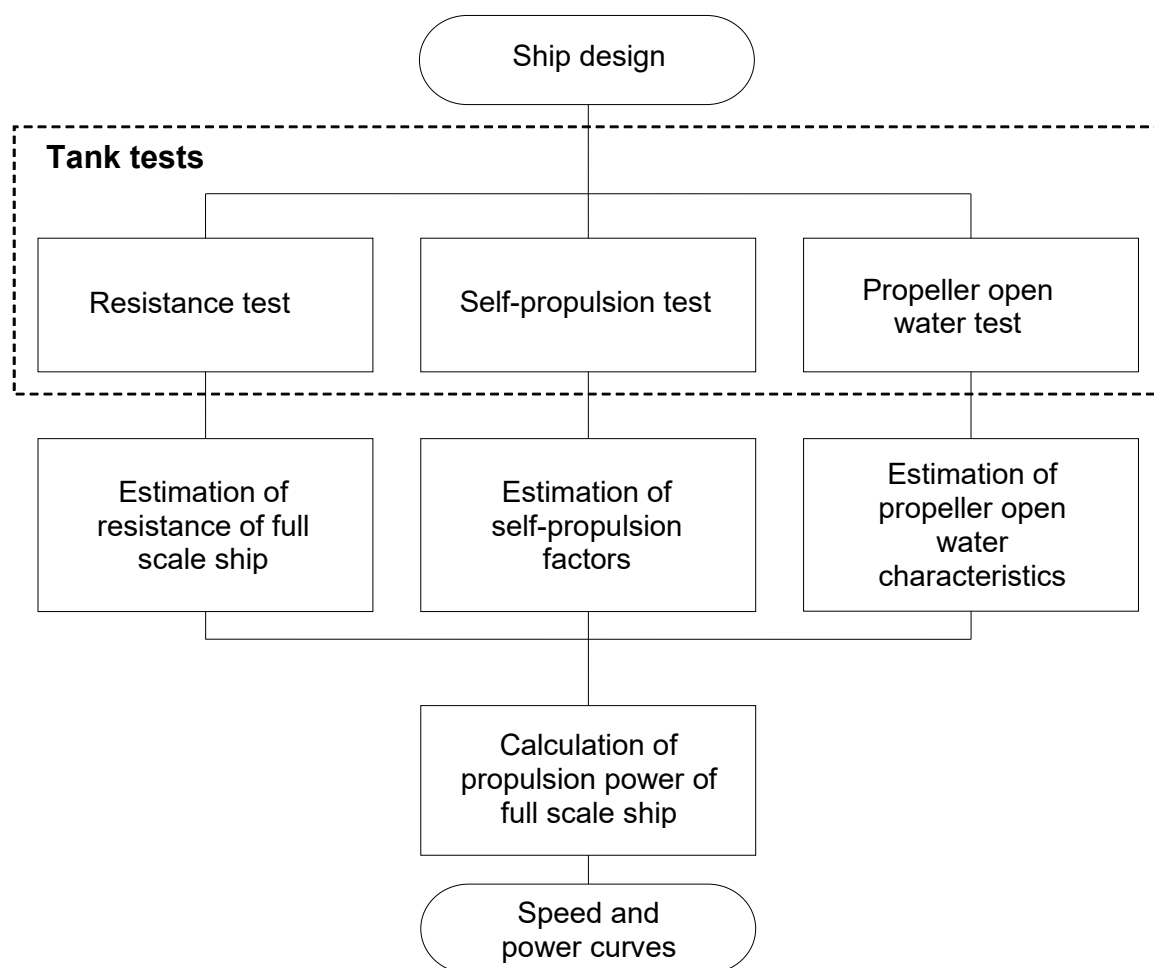

Figure 4.1: Flow chart of process for estimating power curves

5 Description of energy-saving equipment

5.1 Energy-saving equipment the effects of which are expressed as $P_{AEff(i)}$ and/or $P_{eff(i)}$ in the EEDI calculation formula

N/A

5.2 Other energy-saving equipment

(Example)

5.2.1 Rudder fins

5.2.2 Propeller boss cap fins

.....
(Specifications, schematic figures and/or photos, etc., for each piece of equipment or device should be indicated. Alternatively, attachment of a commercial catalogue may be acceptable.)

6 Calculated value of attained EEDI

6.1 Basic data

Type of ship	Capacity DWT	Speed V_{ref} (knots)
Bulk Carrier	150,000	14.25

6.2 Main engine

MCR_{ME} (kW)	Shaft gen.	P_{ME} (kW)	Type of fuel	C_{FME}	SFC_{ME} (g/kWh)
15,000	N/A	11,250	Diesel Oil	3.206	165.0

6.3 Auxiliary engines

P_{AE} (kW)	Type of fuel	C_{FAE}	SFC_{AE} (g/kWh)
625	Diesel Oil	3.206	220.0

6.4 Ice class

N/A

6.5 Innovative electrical energy-efficient technology

N/A

6.6 Innovative mechanical energy-efficient technology

N/A

6.7 Cubic capacity correction factor

N/A

6.8 Calculated value of attained EEDI

$$\begin{aligned}
 EEDI &= \frac{\left(\prod_{j=1}^M f_j \right) \left(\sum_{i=1}^{nME} P_{ME(i)} \cdot C_{FME(i)} \cdot SFC_{ME(i)} \right) + (P_{AE} \cdot C_{FAE} \cdot SFC_{AE})}{f_i \cdot f_c \cdot Capacity \cdot f_w \cdot V_{ref}} \\
 &+ \frac{\left\{ \left(\prod_{j=1}^M f_j \cdot \sum_{i=1}^{nPTI} P_{PTI(i)} - \sum_{i=1}^{neff} f_{eff(i)} \cdot P_{AEeff(i)} \right) C_{FAE} \cdot SFC_{AE} \right\} - \left(\sum_{i=1}^{neff} f_{eff(i)} \cdot P_{eff(i)} \cdot C_{FME} \cdot SFC_{ME} \right)}{f_i \cdot f_c \cdot Capacity \cdot f_w \cdot V_{ref}} \\
 &= \frac{1 \times (11250 \times 3.206 \times 165.0) + (625 \times 3.206 \times 220.0) + 0 - 0}{1 \cdot 1 \cdot 150000 \cdot 1 \cdot 14.25} \\
 &= 2.99 \quad (\text{g} - \text{CO}_2/\text{ton} \cdot \text{mile})
 \end{aligned}$$

attained EEDI: 2.99 g-CO₂/ton mile

7 Calculated value of attained EEDI_{weather}

7.1 Representative sea conditions

	Mean wind speed	Mean wind direction	Significant wave height	Mean wave period	Mean wave direction
BF6	12.6 (m/s)	0 (deg.)*	3.0 (m)	6.7 (s)	0 (deg.)*

* Heading direction of wind/wave in relation to the ship's heading, i.e. 0 (deg.) means the ship is heading directly into the wind.

7.2 Calculated weather factor, f_w

f_w	0.900
-------	-------

7.3 Calculated value of attained EEDI_{weather}

attained EEDI_{weather}: 3.32 g-CO₂/ton mile

APPENDIX 2

GUIDELINES FOR VALIDATION OF ELECTRIC POWER TABLES FOR EEDI (EPT-EEDI)

1 INTRODUCTION

The purpose of these guidelines is to assist recognized organizations in the validation of electric power tables (EPT) for the calculation of the Energy Efficiency Design Index (EEDI) for ships. As such, these guidelines support the implementation of the EEDI Calculation Guidelines and the *Guidelines on survey and certification of the Energy Efficiency Design Index (EEDI)*. These guidelines will also assist shipowners, shipbuilders, ship designers and manufacturers in relation to aspects of the development of more energy-efficient ships and also in understanding the procedures for the EPT-EEDI validation.

2 OBJECTIVES

These guidelines provide a framework for the uniform application of the EPT-EEDI validation process for ships for which required auxiliary engine power is calculated under paragraph 2.2.5.7 of the EEDI Calculation Guidelines.

3 DEFINITIONS

3.1 *Applicant* means an organization, primarily a shipbuilder or a ship designer, which requests the EPT-EEDI validation in accordance with these guidelines.

3.2 *Validator* means a recognized organization which conducts the EPT-EEDI validation in accordance with these guidelines.

3.3 *Validation* for the purpose of these Guidelines means review of submitted documents and survey during construction and sea trials.

3.4 *Standard EPT-EEDI-Form* refers to the layout given in appendix 3, containing the EPT-EEDI results that will be the subject of validation. Other supporting documents submitted for this purpose will be used as reference only and will not be subject to validation.

3.5 P_{AE} herein is defined as per the definition in paragraph 2.2.5.6 of the EEDI Calculation Guidelines.

3.6 *Ship service and engine-room loads* refer to all the load groups which are needed for the hull, deck, navigation and safety services, propulsion and auxiliary engine services, engine-room ventilation and auxiliaries and ship's general services.

3.7 *Diversity factor* is the ratio of the "total installed load power" and the "actual load power" for continuous loads and intermittent loads. This factor is equivalent to the product of service factors for load, duty and time.

4 APPLICATION

4.1 These guidelines are applicable to ships as stipulated in paragraph 2.2.5.7 of the EEDI Calculation Guidelines.

4.2 These guidelines should be applied for new ships for which an application for an EPT-EEDI validation has been submitted to a validator.

- 4.3 The steps of the validation process include:
- .1 review of documents during the design stage
 - .1 check if all relevant loads are listed in the EPT;
 - .2 check if reasonable service factors are used; and
 - .3 check the correctness of the P_{AE} calculation based on the data given in the EPT.
 - .2 survey of installed systems and components during construction stage
 - .1 check if a randomly selected set of installed systems and components are correctly listed with their characteristics in the EPT.
 - .3 survey of sea trials
 - .1 check if selected units/loads specified in EPT are observed.

5 SUPPORTING DOCUMENTS

5.1 The applicant should provide as a minimum the ship electric balance load analysis.

5.2 Such information may contain shipbuilders' confidential information. Therefore, after the validation, the validator should return all or part of such information to the applicant at the applicant's request.

5.3 A special EEDI condition during sea trials may be needed and defined for each ship and included in the sea trial schedule. For this condition, a special column should be inserted into the EPT.

6 PROCEDURES FOR VALIDATION

6.1 General

P_{AE} should be calculated in accordance with the EPT-EEDI Calculation Guidelines. EPT-EEDI validation should be conducted in two stages: preliminary validation at the design stage and final validation during sea trials. The validation process is presented in figure 1.

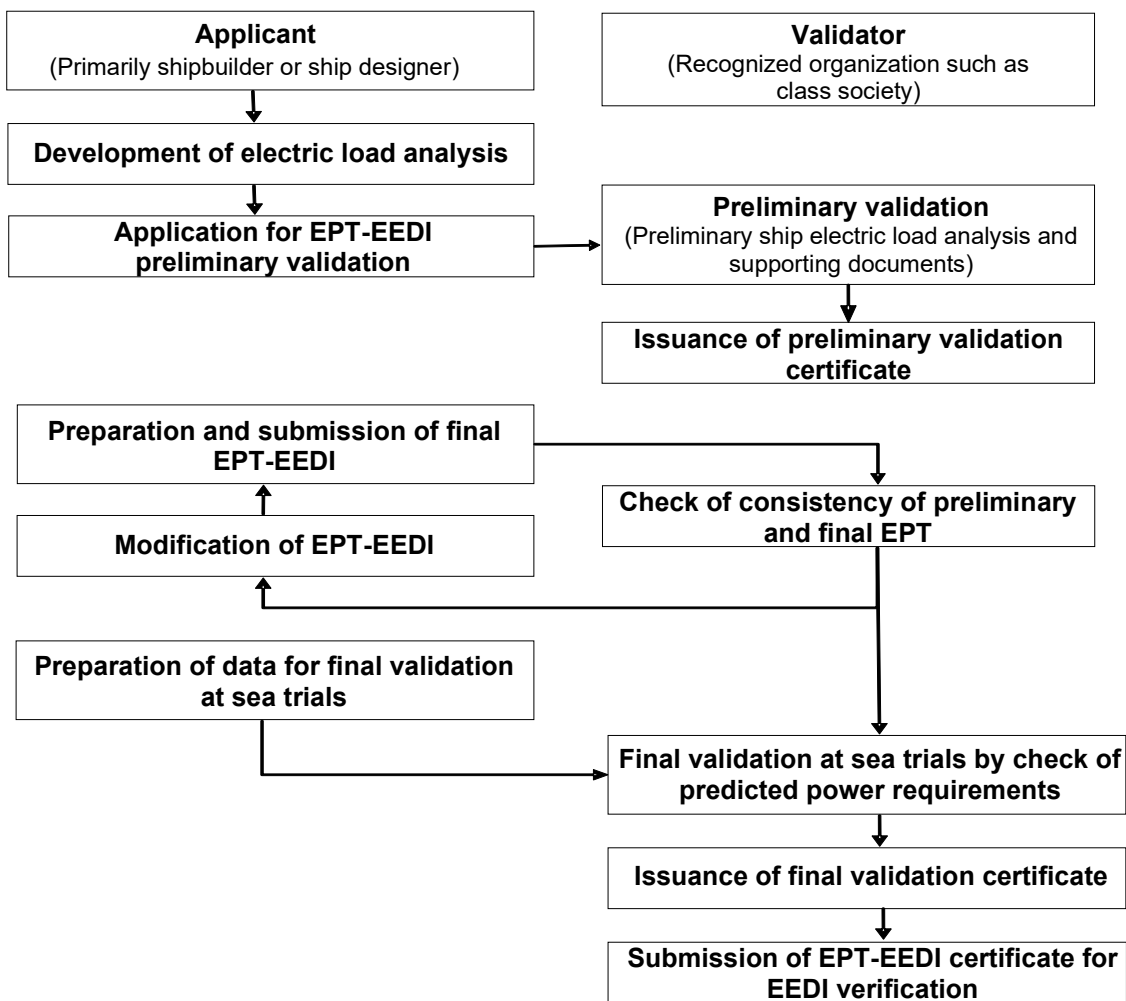

Figure 1: Basic flow of EPT-EEDI validation process

6.2 Preliminary validation at the design stage

6.2.1 For the preliminary validation at the design stage, the applicant should submit to a validator an application for the validation of EPT-EEDI, inclusive of the EPT-EEDI Form, and all the relevant and necessary information for the validation as supporting documents.

6.2.2 The applicant should supply as a minimum the supporting data and information, as specified in appendix A (to be developed).

6.2.3 The validator may request from the applicant additional information to that contained in these Guidelines, as necessary, to enable the validator to examine the calculation process of the EPT-EEDI. The estimation of the ship EPT-EEDI at the design stage depends on each applicant's experience, and it may not be practicable to fully examine the technical aspects and details of each machinery component. Therefore, the preliminary validation should focus on the calculation process of the EPT-EEDI that should follow best marine practices.

Note: A possible way forward for more robust validation is to establish a standard methodology of deriving the ship EPT by setting standard formats as agreed and used by industry.

6.3 Final validation

6.3.1 The final validation process should as a minimum include a check of the ship electric load analysis to ensure that all electric consumers are listed, and that their specific data and the calculations in the power table itself are correct and are supported by sea trial results. If necessary, additional information has to be requested.

6.3.2 For the final validation, the applicant should revise the EPT-EEDI Form and supporting documents as necessary, by taking into account the characteristics of the machinery and other electrical loads actually installed on board the ship. The EEDI condition at sea trials should be defined and the expected power requirements in these conditions documented in the EPT. Any changes within the EPT from design stage to construction stage should be highlighted by the shipyard.

6.3.3 The preparation for the final validation includes a desktop check comprising:

- .1 consistency of preliminary and final EPT;
- .2 changes of service factors (compared to the preliminary validation);
- .3 all electric consumers are listed;
- .4 their specific data and the calculations in the power table itself are correct; and
- .5 in case of doubt, component specification data is checked in addition.

6.3.4 A survey prior to sea trials is performed to ensure that machinery characteristics and data as well as other electric loads comply with those recorded in the supporting documents. This survey does not cover the complete installation but selects randomly a number of samples.

6.3.5 For the purpose of sea trial validation, the surveyor will check the data of selected systems and/or components given in the special column added to the EPT for this purpose or the predicted overall value of electric load by means of practicable measurements with the installed measurement devices.

7 ISSUANCE OF THE EPT-EEDI STATEMENT OF VALIDATION

7.1 The validator should stamp the EPT-EEDI Form as "Noted" having validated the EPT-EEDI in the preliminary validation stage, in accordance with these guidelines.

7.2 The validator should stamp the EPT-EEDI Form as "Endorsed" having validated the final EPT-EEDI in the final validation stage in accordance with these guidelines.

APPENDIX 3

**ELECTRIC POWER TABLE FORM FOR ENERGY EFFICIENCY DESIGN INDEX
(EPT-EEDI FORM) AND STATEMENT OF VALIDATION**

Ship ID:

IMO no.: _____
Ship's name: _____
Shipyard: _____
Hull no.: _____

Applicant:

Name: _____
Address: _____

Validation stage:

Preliminary validation
Final validation

Summary results of EPT-EEDI

Load group	Seagoing condition EEDI Calculation Guidelines		Remarks
	Continuous load (kW)	Intermittent load (kW)	
Ship service and engine-room loads			
Accommodation and cargo loads			
Total installed load			
Diversity factor			
Normal seagoing load			
Weighted average efficiency of generators			
P_{AE}			

Supporting documents

Title	ID or remarks

Validator details:

Organization: _____
Address: _____

This is to certify that the above-mentioned electrical loads and supporting documents have been reviewed in accordance with EPT-EEDI Validation guidelines and the review shows a reasonable confidence for use of the above P_{AE} in EEDI calculations.

Date of review: _____ Statement of validation no. _____

This statement is valid on condition that the electric power characteristics of the ship do not change.

Signature of Validator

Printed name:
