

W10 Spheroidal graphite iron castings or ductile iron castings

(1978)
(Rev.1
1995)
(Rev.2
May 2004)
(Complete
Revision,
Rev.3
Feb 2025)
(Corr.1
Sep 2025)

1 Scope

1.1 All spheroidal graphite iron castings or ductile iron castings (hereafter referred to as Spheroidal graphite iron castings), as defined in the applicable construction Rules, are to be manufactured and tested in accordance with the requirements of the following paragraphs.

1.2 These requirements are applicable to spheroidal graphite iron casting grades where the design and acceptance tests are related to mechanical properties at low or room temperature.

1.3 For castings intended for service at elevated temperature, additional test requirements may be necessary.

1.4 These requirements cover grades of ferritic-to-pearlitic and solid solution strengthened ferritic spheroidal graphite cast irons classified on the basis of mechanical properties measured on test specimens prepared from either separately cast, side-by-side cast or cast-on test blocks.

1.5 Spheroidal graphite iron castings which comply with national/ international standards or proprietary specifications may be accepted provided such specifications give reasonable equivalence to these requirements or otherwise are specially approved or required by the individual Classification Society.

1.6 Where small castings are produced in large quantities the manufacturer may adopt alternative procedures for testing and inspection subject to the approval of the individual Classification Society.

Note:

1. Rev.3 of this UR is to be uniformly implemented by IACS Societies to ships contracted for construction on or after 1 January 2027.
 2. The “contracted for construction” date means the date on which the contract to build the vessel is signed between the prospective owner and the shipbuilder. For further details regarding the date of “contract for construction”, refer to IACS Procedural Requirement (PR) No. 29.
-

2 Manufacture

2.1 Castings are to be made at foundries where the manufacturer has demonstrated to the satisfaction of the Classification Society that the necessary manufacturing and testing facilities are available and are supervised by qualified personnel. A programme of approval tests shall be required in accordance with the procedures of individual Classification Societies.

2.2 Suitable mechanical methods are to be employed for the removal of surplus material from castings in accordance with recognised good practice. Thermal cutting processes such as flame cutting, scarfing or arc-air gouging are not acceptable, except as a preliminary operation to mechanical methods.

2.3 Where castings of the same type are regularly produced in quantity, the manufacturer is to make any tests necessary to prove the quality of the prototype castings and is also to make periodical examinations to verify the continued efficiency of the manufacturing technique. The Surveyor is to be given the opportunity to witness these tests.

3 Quality of castings

3.1 Castings are to be free from surface or internal defects which would be prejudicial to their proper application in service. The surface finish is to be in accordance with good practice and any specific requirements of the approved plan.

4 Chemical composition

4.1 Unless otherwise required by the individual Classification Society for specific applications, the chemical composition of the spheroidal graphite cast iron is left to the discretion of the manufacturer, who is to ensure that it is suitable to obtain the mechanical properties specified for the casting grade. When required by individual Classification Societies the chemical composition of ladle samples is to be reported.

5 Heat treatment

5.1 Except as required by 5.3 castings may be supplied in either the as cast or heat treated condition.

5.2 The delivery condition shall meet the design and application requirements. It is the manufacturers responsibility to select the appropriate heat treatment method and cycle. The description of the entire heat treatment method and cycle is to be submitted to the Classification Society, including any surface hardening.

5.3 Castings for components such as crankshafts and engine bedplates, where dimensional stability and freedom from residual stresses are important, it may be required that castings be given a suitable tempering or stress relieving heat treatment. This is to be carried out after any refining heat treatment and before machining. The Charpy V-notch impact tested casting grades may require a ferritizing heat treatment. The manufacturer shall control the temperature in order to avoid any detrimental effects to the microstructure and mechanical properties of the casting.

5.4 Where it is proposed to locally harden the surfaces of a casting full details of the proposed manufacturing procedure and specification are to be submitted for approval by the Classification Society.

5.5 Heat treatment should be carried out in properly constructed furnaces which are efficiently maintained, subjected to regular temperature uniformity survey and have adequate

means for control and recording of temperature. The furnace dimensions are to be such as to allow the whole casting to be uniformly heated to the necessary temperature. In the case of very large castings alternative methods for heat treatment will be specially considered by the individual Classification Society.

5.6 Records of heat treatment of each batch shall be maintained by the manufacturer and are to be presented to the Surveyor on request.

6 Mechanical tests

6.1 Test material, sufficient for the required tests and for possible re-test purposes, is to be provided for each casting or batch of castings.

6.2 Separately cast or side-by-side test blocks are generally preferred and of the types detailed in either Figs. 1a, 1b or Fig.2 with a thickness of 25 mm used as the standard type. Separately cast or side-by-side test blocks of other dimensions (Fig. 2) may be specified based on the relevant wall thickness of the casting and when specially agreed between the manufacturer, the purchaser and the individual Classification Society.

6.3 When agreed between the Manufacturer and the purchaser, cast-on test blocks may be used. The dimensions of the cast-on test blocks shall be as detailed in Fig 3.

Note:

1. Separately cast blocks: Test blocks cast in a separate sand mould under representative manufacturing conditions.
2. Side-by-side (attached to the casting) cast blocks: Test blocks cast in the same mould and attached (or gated) to the casting with a common running system.
3. Cast-on test blocks: Test blocks attached directly to the casting.
4. Relevant wall thickness: Section of the casting, agreed between the manufacturer and the purchaser, to which the determined mechanical properties apply.

6.4 At least one test block is to be provided for each casting or batch of castings.

6.5 For large castings where more than one ladle of treated metal is used, additional test blocks are to be provided so as to be representative of each ladle used.

6.6 As an alternative to 6.4, a batch testing procedure may be adopted for castings with a fettled mass (castings with feeding and running systems removed) of 1,0 tonne or less. All castings in a batch are to be of similar shape and dimensions, cast from the same ladle of treated metal and, where applicable, which have been heat-treated in the same furnace batch. One separately cast test block is to be provided for each multiple of 2,0 tonnes of fettled castings in the batch. The maximum mass of one batch shall not exceed 2,0 tonnes of fettled castings.

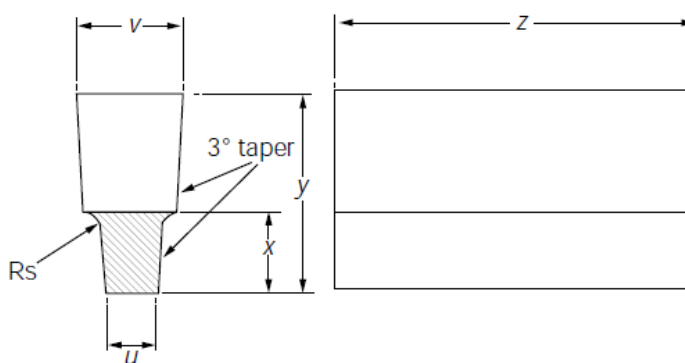

Fig. 1a Type A test blocks (U-type)

Dimensions	Standard	Alternative blocks		
	block	when specially required		
u (mm)	25	12	50	75
v (mm)	55	40	90	125
x (mm)	40	30	60	65
y (mm)	100	80	150	165
z	A function of the test specimen length			
Rs	Approximately 5mm			

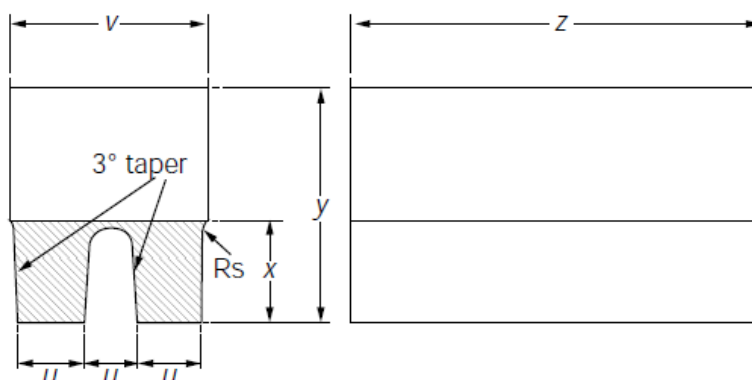

Fig. 1b Type B test blocks (double U-type)

Dimensions	Standard
	Block
u (mm)	25
v (mm)	90
x (mm)	40
y (mm)	100
z	A function of the test specimen length
Rs	Approximately 5 mm

Thickness of the sand mould surrounding the block shall be at least 40 mm.

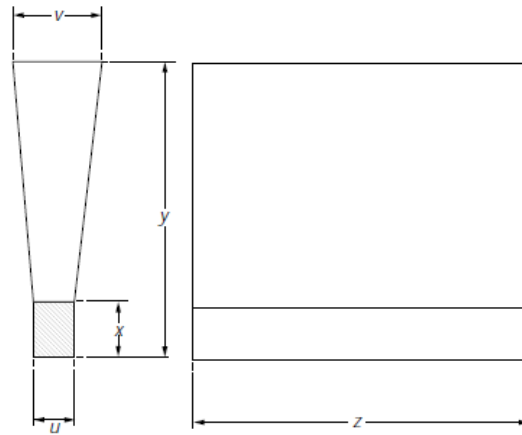

Fig2. Separately cast or side-by-side cast blocks (Y-shaped block)

Dimensions	Standard	Alternative blocks		
	block	when specially required		
u (mm)	25	12.5	50	75
v (mm)	55	40	100	125
x (mm)	40	25	50	65
y (mm)	140	135	150	175
z	A function of the test specimen length			
Thickness of Sand mould surrounding test block	40 mm min.	40 mm min.	80 mm min.	80 mm min.
Relevant wall thickness (mm)	$12.5 < t \leq 30$	$t \leq 12.5$	$30 < t \leq 60$	$60 < t \leq 200$

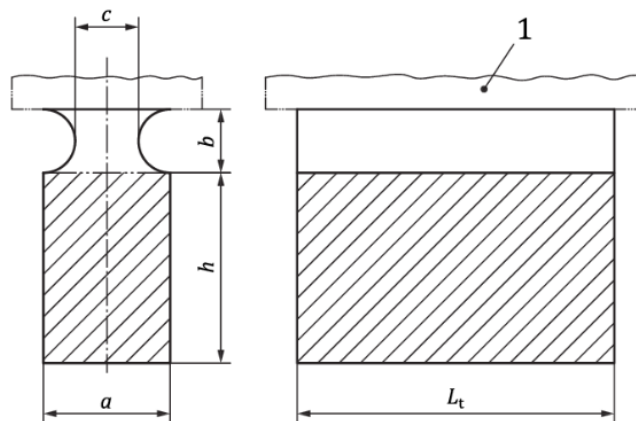

Fig 3. Cast-on test block

Key

1. Iron casting

Type	Relevant wall thickness of casting, t , mm	a (mm)	b (mm) max.	c (mm) min.	h (mm)	L_t (mm)
A	$t \leq 12.5$	15	11	7.5	20 to 30	See Note
B	$12.5 < t \leq 30$	25	19	12.5	30 to 40	
C	$30 < t \leq 60$	40	30	20	40 to 65	
D	$60 < t \leq 200$	70	52.5	35	65 to 105	

Note: A function of the test specimen length.

Thickness of the sand mould surrounding the blocks shall be at least:

- 40mm for types A and B
- 80 mm for types C and D

If smaller dimensions are agreed between the Manufacturer and the purchaser, the following relationship apply;

$$b \geq 0.75a$$

$$c \geq 0.5a$$

6.7 Where separately cast test blocks are used, they are to be cast in moulds made from the same type of material as used for the castings and are to be taken towards the end of pouring of the castings. The cast test blocks are not to be stripped from the moulds until the temperature is below 500°C.

6.8 All test blocks are to be suitably marked to identify them with the castings which they represent.

6.9 Where castings are supplied in the heat-treated condition, the test blocks are to be heat treated together with the castings which they represent.

6.10 One tensile test specimen is to be prepared from each test block and is to be machined to the dimensions given in IACS UR W2.

6.11 All tensile tests are to be carried out using test procedures in accordance with IACS UR W2. Unless otherwise agreed all tests are to be carried out in the presence of the Surveyors.

6.12 Charpy V-notch impact tests are additionally required for the low temperature (LT) and room temperature (RT) grades. Where Charpy V-notch test specimens are used, the dimensions and testing procedures are to be in accordance with IACS UR W2.

When required, Charpy V-notch impact tests are to be carried out in accordance with IACS UR W2. Unless otherwise agreed all tests are to be carried out in the presence of the Surveyors.

6.13 At the option of the manufacturer and with agreement of the Classification Society, when a casting or batch of castings has failed to meet the test requirements, it may be re-heat treated and re-submitted for acceptance tests.

7 Mechanical properties

7.1 Table 1 gives the minimum requirements for 0,2% proof stress, tensile strength, elongation and Charpy V-notch impact toughness corresponding to different grades applicable to either separately cast, side-by-side cast or cast-on test blocks of standard thickness or diameter of 25 mm.

7.2 Table 2 gives the minimum requirements for 0,2% proof stress, tensile strength, elongation and Charpy V-notch impact toughness corresponding to different grades and applicable relevant wall thicknesses for separately cast, side-by-side or cast-on test blocks of alternative dimensions, as agreed between the manufacturer and the purchaser.

7.3 Castings may be supplied to any of the grades included in Table 1 and Table 2, but subject to any additional requirements of the relevant construction Rules.

Table 1 Mechanical properties measured on test specimens machined from either separately cast, side-by-side cast or cast-on test blocks with standard thickness or diameter of 25 mm only.

Spheroidal graphite cast iron type	Grade	0,2% proof strength (min)	Tensile strength, N/mm ² (min)	Elongation on $5,65 \sqrt{S_0}$ (%) min	Average impact energy, J (min).			Recommended matrix structure
					RT (23±5) °C	LT (-20±2) °C	LT (-40±2) °C	
Ferritic-to-pearlitic	350-22-LT	220	350	22	-	-	12	Ferrite
	350-22-RT	220	350	22	17	-	-	Ferrite
	350-22	220	350	22	-	-	-	Ferrite
	400-18-LT	240	400	18	-	12	-	Ferrite
	400-18-RT	250	400	18	14	-	-	Ferrite
	400-18	250	400	18	-	-	-	Ferrite
	400-15	250	400	15	-	-	-	-
	450-10	310	450	10	-	-	-	Ferrite
	500-7	320	500	7	-	-	-	Ferrite-pearlite
	550-5	350	550	5	-	-	-	Ferrite-pearlite
	600-3	370	600	3	-	-	-	Pearlite-ferrite
	700-2	420	700	2	-	-	-	Pearlite
	800-2	480	800	2	-	-	-	Pearlite or tempered martensite
	900-2	600	900	2	-	-	-	Tempered martensite or bainite
Solid solution strength	450-18	350	450	18	-	-	-	Ferrite (See note)

ened ferritic	500-14	400	500	14	-	-	-	Ferrite (See note)
	600-10	470	600	10	-	--	-	Ferrite (See note)

LT: Low temperature, RT: Room temperature.

Note: The matrix structure should be predominantly ferrite with a maximum pearlite content of 5 %. The amount of free cementite should not exceed 1 %.

Table 2 Mechanical properties measured on test specimens machined from either separately cast (Y- shaped block), side-by-side (Y- shaped block) cast or cast-on test blocks (see Note 1&5).

Spheroidal graphite cast iron type	Grade	Relevant wall thickness, t mm (See Note 2&3)	0,2% proof strength (min)	Tensile strength, N/mm ² (min)	Elongation on 5,65 $\sqrt{S_0}$ (%) <i>m</i>	Average impact energy, J (min).			Recommended matrix structure
						RT (23±5) °C	LT (-20±2) °C	LT (-40±2) °C	
Ferritic-to-pearlitic	350-22-LT	30<t≤60 60<t≤200	210 200	330 320	18 15	- -	- -	12 10	Ferrite
	350-22-RT	30<t≤60 60<t≤200	220 210	330 320	18 15	17 15	- -	- -	Ferrite
	350-22	30<t≤60 60<t≤200	220 210	330 320	18 15	- -	- -	- -	Ferrite
	400-18-LT	30<t≤60 60<t≤200	230 220	380 360	15 12	- -	12 10	- -	Ferrite
	400-18-RT	30<t≤60 60<t≤200	250 240	390 370	15 12	14 12	- -	- -	Ferrite
	400-18	30<t≤60 60<t≤200	250 240	390 370	15 12	- -	- -	- -	Ferrite
	400-15	30<t≤60 60<t≤200	250 240	390 370	14 11	- -	- -	- -	-
	450-10	30<t≤60 60<t≤200	To be agreed upon between the Manufacturer and the purchaser			- -	- -	- -	Ferrite

	500-7	30<t≤60 60<t≤200	300 290	450 420	7 5	- -	- -	- -	Ferrite-pearlite
	550-5	30<t≤60 60<t≤200	330 320	520 500	4 3	- -	- -	- -	Ferrite-pearlite
	600-3	30<t≤60 60<t≤200	360 340	600 550	2 1	- -	- -	- -	Pearlite-ferrite
	700-2	30<t≤60 60<t≤200	400 380	700 650	2 1	- -	- -	- -	Pearlite
	800-2	30<t≤60 60<t≤200	To be agreed upon between the Manufacturer and the purchaser			- -	- -	- -	Pearlite or tempered martensite
	900-2	30<t≤60 60<t≤200	To be agreed upon between the Manufacturer and the purchaser			- -	- -	- -	Tempered martensite or bainite
Solid solution strengthened ferritic	450-18	30≤t≤60	340	430	14	-	-	-	Ferrite (See note 4)
		t>60	To be agreed upon between the Manufacturer and the purchaser			-	-	-	
	500-14	30≤t≤60	390	480	12	-	-	-	Ferrite (See note 4)
		t>60	To be agreed upon between the Manufacturer and the purchaser			-	-	-	
	600-10	30≤t≤60	450	580	8	-	-	-	Ferrite (See note 4)
		t>60	To be agreed upon between the Manufacturer and the purchaser			-	-	-	

LT: Low temperature, RT: Room temperature.

Note 1: Test block dimensions are selected on the basis of the relevant wall thickness as specified in Figures 2 or 3 as applicable.

Note 2: For relevant wall thickness $\leq 30\text{mm}$, the mechanical property requirements of table 1 are to be applied.

Note 3: For relevant wall thickness greater than 200 mm, subject to the special consideration by the individual Classification Society, the manufacturer and the purchaser shall agree on the minimum mechanical properties, the type and size of the cast block, and microstructure requirements.

Note 4: The matrix structure should be predominantly ferrite with a maximum pearlite content of 5 %. The amount of free cementite should not exceed 1 %.

Note 5. If a particular type of test block is to be specified, a "/" is added to the designation, followed by a letter indicating the type of test block:

/S = separately cast test block or side-by-side cast test block.

/U = cast-on test block.

/C = sample cut from casting.

7.4 Where Brinell hardness testing is relevant to the application, then a suitable testing method and acceptance criteria consistent with recognised national/ international standards (e.g., ISO 1083:2018 and ISO 6506-1:2014) may be considered subject to the approval of the individual Classification society.

7.5 Re-test requirements for tensile tests and Charpy V-notch impact tests are to be in accordance with IACS UR W2.

8 Inspection

8.1 All castings are to be cleaned and adequately prepared for examination; suitable methods include pickling, caustic cleaning, wire brushing, local grinding, shot or sand blasting. The surfaces are not to be hammered, peened or treated in any way which may obscure defects.

8.2 Before acceptance, all castings are to be presented to the Surveyor for visual examination. The visual examination is to include internal surfaces, where applicable. The castings shall be free from defects which are detrimental to practical use. The verification of dimensions is the responsibility of the manufacturer.

8.3 Supplementary examination of castings by suitable non-destructive testing procedures is generally not required except in circumstances where there is reason to suspect the soundness of the casting.

8.4 When required by the applicable construction Rules or design code, castings are to be pressure tested before final acceptance. The Surveyor is to be given the opportunity to witness these tests.

8.5 In the event of any casting proving defective during subsequent machining or testing, it is to be rejected notwithstanding any previous certification.

8.6 Cast crankshafts are to be subjected to a magnetic particle inspection. Crack like indications are not allowed.

9 Metallographic examination

9.1 A representative sample from each ladle of treated metal is to be prepared for metallographic examination. These samples may conveniently be taken from the tensile test specimens but alternative arrangements for the provision of the samples may be adopted provided that they are taken from the ladle towards the end of the casting period.

9.2 The method for evaluating the nodularity in spheroidal graphite iron castings shall be in accordance with recognised national/international standards such as ISO 945-4:2019. The nodularity of graphite, unless otherwise agreed with the individual classification society, shall meet the requirements of a minimum of 90% graphite in a dispersed spheroidal or nodular form. For the solid solution strengthened ferritic grades, unless otherwise agreed with the individual Classification society, the amount of free cementite shall not exceed 1%.

9.3 The graphite morphology is to be mainly of form V and VI as specified in ISO 945-1:2019.

9.4 In case of specific applications, the relative proportion of micro constituents such as ferrites, pearlites or tempered structures in the matrix of the microstructure may be specified subject to agreement between the manufacturer and the purchaser.

10 Rectification of defective castings

10.1 Subject to agreement by the individual Classification Society, small surface blemishes may be removed by local grinding.

10.2 Subject to the prior approval of the individual Classification Society, castings containing local porosity may be rectified by impregnation with a suitable plastic filler, provided that the extent of the porosity is such that it does not adversely affect the strength of the casting.

10.3 Repairs by welding are generally not permitted unless specially agreed with the individual Classification Society.

11 Identification of castings

11.1 The manufacturer is to adopt a system of identification which will enable all finished castings to be traced to the original cast and the Surveyor is to be given full facilities for so tracing the castings when required.

11.2 Before acceptance, all castings which have been tested and inspected with satisfactory results are to be clearly marked by the manufacturer. At the discretion of individual Classification Societies any of the following particulars may be required.

- (i) The material grade.
- (ii) Identification number, cast number or other marking which will enable the full history of the casting to be traced.
- (iii) Manufacturer's name or trade mark.
- (iv) The Classification Society's name, initials or symbol.
- (v) Abbreviated name of the Classification Society's local office.
- (vi) Personal stamp of Surveyor responsible for inspection.
- (vii) Where applicable, test pressure.
- (viii) Date of final inspection.

11.3 Where small castings are manufactured in large numbers, modified arrangements for identification may be specially agreed with the Classification Society.

12 Certification

12.1 The manufacturer is to provide the required type of inspection certificate giving the following particulars for each casting or batch of castings which has been accepted:

- (i) Purchaser's name and order number.
- (ii) Description of castings.
- (iii) Material grade
- (iv) Cast number or Identification number.
- (v) Results of mechanical tests.
- (vi) Where applicable, general detail of heat treatment including temperatures and holding times.
- (vii) Where specifically required, the chemical analysis of ladle samples.
- (viii) Where applicable, test pressure.
- (ix) Where applicable, results of non-destructive tests.
- (x) Where applicable, results of the metallographic examination.

End of Document
