

# W18 Anchor chain cables and accessories including chafing chain for emergency towing arrangements

(1988)  
(Rev.1  
1997)  
(Rev.2  
July 1999)  
(Rev.3  
July 2002)  
(Rev.4  
July 2003)  
(Rev.5  
May 2004)  
(Rev.6  
Sep 2021)

## W18.1 General requirements

### 1.1 Scope

These rules apply to the materials, design, manufacture and testing of stud link anchor chain cables and accessories used for ships. Where, in exceptional cases, studless short link chain cables are used with the consent of the individual Society, they must comply with recognized national or international standards. The requirements for chafing chain for Emergency Towing Arrangements (ETA) are given in the Appendix A.

### 1.2 Chain cable grades

Depending on the nominal tensile strength of the chain cable steel used for manufacture, stud link chain cables are to be subdivided into Grades 1, 2 and 3.

### 1.3 Approval of chain manufacturers

1.3.1 Anchor chain cables and accessories are to be manufactured only by works approved by the Society. For this purpose approval tests are to be carried out, the scope of which is to be agreed with the Society.

1.3.2 Applications for approval are to be made to the Society, stating the method of manufacture used, the grades of materials, the nominal dimensions and - where applicable - the material specification. A procedure test carried out on a high-strength chain cable may cover approval of lesser grades, provided that the material type, method of manufacture and the nature of the heat treatment are the same.

---

Note:

1. Changes introduced in Rev.6 are to be uniformly implemented by IACS Societies on ships contracted for construction on or after 1 January 2023, or when the application for certification of steel products is dated on or after 1 January 2023, or the application for certification of manufacturer approval is dated on or after 1 January 2023.

2. The "contracted for construction" date means the date on which the contract to build the vessel is signed between the prospective owner and the shipbuilder. For further details regarding the date of "contract for construction", refer to IACS Procedural Requirement (PR) No. 29.

# W18

(cont)

## W18.2 Materials

### 2.1 Scope

These rules apply to rolled steels, forgings and castings used for the manufacture of anchor chain cables and accessories.

### 2.2 Requirements for material manufacturers

2.2.1 All materials used for the manufacture of anchor chain cables and accessories are to be supplied by manufacturers approved by the Society. Society approval is not required for Grade 1 steel bars.

2.2.2 Materials suppliers or chain cable manufacturers are to submit specifications for Grade 3 steel bars. These specifications should contain all necessary details, such as manufacturing procedure, deoxydation practice, specified chemical composition, heat treatment, and mechanical properties.

### 2.3 Rolled steel bars

#### 2.3.1 Supply condition

Unless otherwise stipulated, the steel bars will be supplied in as rolled condition.

#### 2.3.2 Chemical composition

The chemical composition of the steel bars is to be generally within the limits given in Table 1.

**Table 1** Chemical composition of rolled steel bars

Grade	Chemical composition in maximum percent, unless specified.					
	C	Si	Mn	P	S	Al tot <sup>1)</sup> min.
1	0.20	0.15-0.35	min. 0.40	0.040	0.040	NR
2 <sup>2)</sup>	0.24	0.15-0.55	1.60	0.035	0.035	0.020
3 <sup>3)</sup>	In accordance with an approved specification					

<sup>1)</sup> Aluminum may be replaced partly by other grain refining elements.  
<sup>2)</sup> If the Society agrees, additional alloying elements may be added.  
<sup>3)</sup> To be killed and fine grain.  
 NR = Not required.

#### 2.3.3 Mechanical tests

2.3.3.1 Mechanical tests representing the steel bars are normally to be carried out by the steel mill, and the results are to meet the requirements in Table 2. The test coupons are to be in a heat treatment condition equivalent to that of the finished chain cable and accessories.

# W18

(cont)

**Table 2** Mechanical properties of rolled steel bars

Grade	R <sub>eH</sub> N/mm <sup>2</sup> min.	R <sub>m</sub> N/mm <sup>2</sup>	A <sub>5</sub> % min.	Z % min.	Charpy V-notch impact test	
					Test temp. in °C	Absorbed energy in Joules, min.
1	NR	370-490	25	NR	NR	NR
2	295	490-690	22	NR	0	27 <sup>1)</sup>
3	410	min. 690	17	40	0 <sup>2)</sup>	60
					-20	35

<sup>1)</sup> The impact test of Grade 2 materials may be waived, if the chain cable is to be supplied in a heat treated condition as per Table 6.

<sup>2)</sup> Testing is normally to be carried out at 0°C.

NR = Not required.

2.3.3.2 For performance of the mechanical tests the steel bars shall be sorted according to heats and diameters into test units not exceeding 50 tons each. From each test unit a test sample shall be taken for the tests mentioned in 2.3.3.4 and 2.3.3.5. Prior to sampling, the test samples must be subjected to the heat treatment provided for the finished chain cable; see Section 3.3. Details of the heat treatment must be indicated by the chain cable manufacturer.

2.3.3.3 Tensile and Charpy V-notch impact test specimens shall be taken from the test sample in the longitudinal direction at a distance of 1/6 diameter from the surface or as close as possible to this position, as shown in Figure 1.

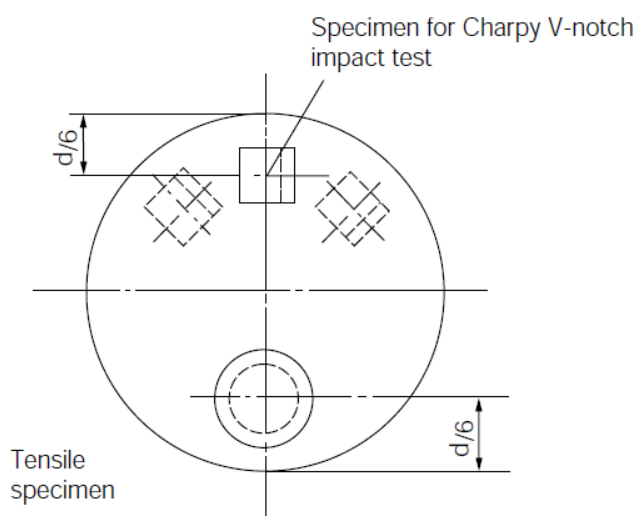

**Figure 1** Sampling Locations

## W18 (cont)

2.3.3.4 For the tensile test, one specimen shall be taken from each test unit and tested, all in accordance with UR W2.

2.3.3.5 One set of longitudinal Charpy V-notch test specimens shall be taken from each test unit and tested at the temperature prescribed in Table 2, all in accordance with UR W2. The specimen transverse axis is to be radial to the steel bar. The average value obtained from one set of three impacts specimens is to comply with the requirements given in Table 2. One individual value only may be below the specified average value provided it is not less than 70% of that value.

2.3.3.6 Re-test requirements for tensile tests are to be in accordance with UR W2 with specimens taken from the same sample. Failure to meet the specified requirements of either of both additional tests will result in rejection of the test unit represented unless it can be clearly attributable to improper simulated heat treatment; see 2.3.3.8.

2.3.3.7 Re-test requirements for Charpy impact tests are to be in accordance with UR W2. Specimens are to be selected from the same sample. Failure to meet the requirements will result in rejection of the test unit represented unless it can be clearly attributable to improper simulated heat treatment; see 2.3.3.8.

2.3.3.8 If failure to pass the tensile test or the Charpy V-notch impact test is definitely attributable to improper heat treatment of the test sample, a new test sample may be taken from the same piece and reheat treated. The complete test (both tensile and impact test) is to be repeated; and the original results obtained may be disregarded.

### 2.3.4 Dimensional tolerances

The diameter and roundness shall be within the tolerances specified in Table 3 unless otherwise agreed.

**Table 3** Dimensional tolerance of rolled steel bars

Nominal diameter mm	Tolerance on diameter mm	Tolerance on roundness ( $d_{\max} - d_{\min}$ ) mm
less than 25	-0 + 1.0	0.6
25 - 35	-0 + 1.2	0.8
36 - 50	-0 + 1.6	1.1
51 - 80	-0 + 2.0	1.5
81 - 100	-0 + 2.6	1.95
101 - 120	-0 + 3.0	2.25
121 - 160	-0 + 4.0	3.00

### 2.3.5 Freedom from defects

The materials have to be free from internal and surface defects that might impair proper workability and use. Surface defects may be repaired by grinding, provided the admissible tolerance is not exceeded.

**W18**  
(cont)

## 2.3.6 Identification of material

Manufacturers are to effectively operate an identification system ensuring traceability of the material to the original cast.

## 2.3.7 Marking

The minimum markings required for the steel bars are the manufacturers' landmark, the steel grade and an abbreviated symbol of the heat. Steel bars having diameters of up to and including 40 mm and combined into bundles, may be marked on permanently affixed labels.

## 2.3.8 Material certification

Bar material for Grade 2 or Grade 3 is to be certified by the Society. For each consignment manufacturers shall forward to the Surveyor a certificate containing at least the following data:

- manufacturer's name and/or purchaser's order No.
- number and dimensions of bars and weight of consignment
- steel specification and chain grade
- heat number
- manufacturing procedure
- chemical composition
- details of heat treatment of the test sample (where applicable)
- results of mechanical tests (where applicable)
- number of test specimens (where applicable)

**2.4 Forged steels for chain cables and accessories**

## 2.4.1 General requirements

Forged steels used for the manufacture of chain cables and accessories are to be in compliance with UR W7, Hull and machinery steel forgings, unless otherwise specified in the following paragraphs.

## 2.4.2 Chemical composition

The chemical composition is to comply with the specification approved by the Society. The steel manufacturer must determine and certify the chemical composition of every heat of material.

## 2.4.3 Heat treatment

The stock material may be supplied in the as rolled condition. Finished forgings are to be properly heat treated, i.e. normalized, normalized and tempered or quenched and tempered, whichever is specified for the relevant steel grade in Table 4.

**2.5 Cast steels for chain cables and accessories**

## 2.5.1 General requirements

Cast steels used for the manufacture of chain cables and accessories are to be in compliance with UR W8, Hull and machinery steel castings, unless otherwise specified in the following paragraphs.

## 2.5.2 Chemical composition

## W18 (cont)

The chemical composition is to comply with the specification approved by the Society. The foundry is to determine and certify the chemical composition of every heat.

### 2.5.3 Heat treatment

All castings must be properly heat treated, i.e., normalized, normalized and tempered or quenched and tempered, whichever is specified for the relevant cast steel grade in Table 4.

## 2.6 Materials for studs

The studs are to be made of steel corresponding to that of the chain cable or from rolled, cast or forged mild steels. The use of other materials, e.g. grey or nodular cast iron is not permitted.

### W18.3 Design and manufacture of chain cables and accessories

#### 3.1 Design

Chain cables must be designed according to a standard recognized by the Society, such as 1704:2008. A length of chain cable must comprise an odd number of links. Where designs do not comply with this and where accessories are of welded construction, drawings giving full details of the design, the manufacturing process and the heat treatment are to be submitted to the Society for approval.

#### 3.2 Dimensions and dimensional tolerances

3.2.1 The shape and proportions of links and accessories must conform to a recognized standard, such as ISO 1704:2008 or the designs specially approved.

3.2.2. The following tolerances are applicable to links:

a) Diameter measured at the crown (Two measurements are to be taken at the same location: one in the plane of the link{see dp in Figure 2}, and one perpendicular to the plane of the link):

up to 40mm nominal diameter	: – 1mm
over 40 up to 84mm nominal diameter	: – 2mm
over 84 up to 122mm nominal diameter	: – 3mm
over 122mm nominal diameter	: – 4mm

The plus tolerance may be up to 5% of the nominal diameter. The cross sectional area of the crown must have no negative tolerance.

b) Diameter measured at locations other than the crown:

The diameter is to have no negative tolerance. The plus tolerance may be up to 5% of the nominal diameter. The approved manufacturer's specification is applicable to the plus tolerance of the diameter at the flush-butt weld.

c) The maximum allowable tolerance on assembly measured over a length of 5 links may equal +2.5%, but may not be negative (measured with the chain under tension after proof load test).

## W18 (cont)

d) All other dimensions are subject to a manufacturing tolerance of  $\pm 2.5\%$ , provided always that all of the final link parts of the chain cable fit together properly.

e) Studs must be located in the links centrally and at right angles to the sides of the link, although the studs at each end of any length may also be located off-centre to facilitate the insertion of the joining shackle. The following tolerances are regarded as being inherent in the method of manufacture and will not be objected to provided that the stud fits snugly and its ends lie practically flush against the inside of the link.

Maximum off-centre distance "X" : 10% of the nominal diameter d

Maximum deviation " $\alpha$ " from the  $90^\circ$  - position :  $4^\circ$

The tolerances are to be measured in accordance with Figure 2.

3.2.3 The following tolerances are applicable to accessories:

nominal diameter : + 5%, -0%

other dimensions : + 2.5%

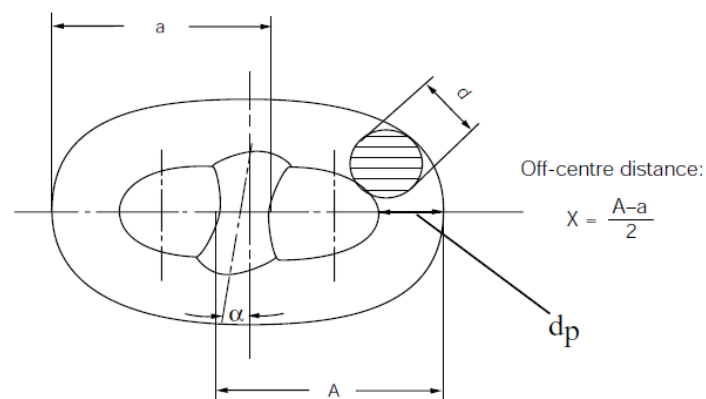

**Figure 2** Manufacturing tolerances

### 3.3 Manufacturing process

3.3.1 Stud link chain cables should preferably be manufactured by flash butt welding using Grade 1, 2 or 3 bar material. Manufacture of the links by drop forging or castings is permitted. On request, pressure butt welding may also be approved for studless, Grade 1 and 2 chain cables, provided that the nominal diameter of the chain cable does not exceed 26mm.

3.3.2 Accessories such as shackles, swivels and swivel shackles are to be forged or cast in steel of at least Grade 2. The welded construction of these parts may also be approved.

### 3.4 Welding of studs

The welding of studs is to be in accordance with an approved procedure subject to the following conditions:

- The studs must be of weldable steel; cf. 2.6.
- The studs are to be welded at one end only, i.e., opposite to the weldment of the link. The stud ends must fit the inside of the link without appreciable gap.
- The welds, preferably in the horizontal position, shall be executed by qualified welders using suitable welding consumables.
- All welds must be carried out before the final heat treatment of the chain cable.

# W18 (cont)

- e) The welds must be free from defects liable to impair the proper use of the chain. Under-cuts, end craters and similar defects shall, where necessary, be ground off.

The Society reserves the right to call for a procedure test for the welding of chain studs.

## 3.5 Heat treatment

According to the grade of steel, chain cables and accessories are to be supplied in one of the conditions specified in Table 4. The heat treatment shall in every case be performed before the proof load test, the breaking load test, and all mechanical testing.

The mechanical properties of finished chain cables and accessories are to be in accordance with Table 7.

**Table 4** Condition of supply of chain cables and accessories

Grade	Chain cables	Accessories
1	As welded or Normalized	NA
2	As welded or Normalized <sup>1)</sup>	Normalized
3	Normalized, Normalized and tempered or Quenched and tempered	Normalized, Normalized and tempered or Quench and tempered
<p><sup>1)</sup> Grade 2 chain cables made by forging or casting are to be supplied in the normalized condition.</p> <p>NA = Not Applicable.</p>		

## 3.6 Freedom from defects

3.6.1 All individual parts must have a clean surface consistent with the method of manufacture and be free from cracks, notches, inclusions and other defects impairing the performance of the product. The flashes produced by upsetting or drop forging must be properly removed.

3.6.2 Minor surface defects may be ground off so as to leave a gentle transition to the surrounding surface. Remote from the crown local grinding up to 5% of the nominal link diameter may be permitted.

## W18.4 Testing and certification of finished chain cables

### 4.1 Proof and breaking load tests

4.1.1 Finished chain cables are to be subjected to the proof load test and the breaking load test in the presence of the Surveyor, and shall not fracture or exhibit cracking. Special attention is to be given to the visual inspection of the flash-butt weld, if present. For this purpose, the chain cables must be free from paint and anti-corrosion media.

4.1.2 Each chain cable length (27.5 m) is to be subjected to a loading test at the proof load appropriate to the particular chain cable as given by Table 5 and using an approved testing machine.



**Table 5** Formulas for proof load and breaking load tests

Test	Grade 1	Grade 2	Grade 3
Proof load (kN)	$0.00686d^2(44-0.08d)$	$0.00981d^2(44-0.08d)$	$0.01373d^2(44-0.08d)$
Breaking load (kN)	$0.00981d^2(44-0.08d)$	$0.01373d^2(44-0.08d)$	$0.01961d^2(44-0.08d)$

**Note:** d = nominal diameter, in mm.

4.1.3 For the breaking load test, one sample comprising at least of three links is to be taken from every four lengths or fraction of chain cables and tested at the breaking loads given by Table 5. The breaking load is to be maintained for a minimum of 30 seconds. The links concerned shall be made in a single manufacturing cycle together with the chain cable and must be welded and heat treated together with it. Only after this may they be separated from the chain cable in the presence of the Surveyor.

4.1.4 If the tensile loading capacity of the testing machine is insufficient to apply the breaking load for chain cables of large diameter, another equivalent testing method shall be agreed with the Society.

## 4.2 Retests

4.2.1 Should a breaking load test fail, a further test specimen may be taken from the same length of chain cable and tested. The test shall be considered successful if the requirements are then satisfied.

If the retest fails, the length of chain cable concerned shall be rejected. If the manufacturer so wishes, the remaining three lengths belonging to the unit test quantity may then be individually subjected to test at the breaking load. If one such test fails to meet the requirements, the entire unit test quantity is rejected.

4.2.2 Should a proof load test fail, the defective link(s) is (are) to be replaced, a local heat treatment to be carried out on the new link(s) and the proof load test is to be repeated. In addition, an investigation is to be made to identify the cause of the failure.

## 4.3 Mechanical tests on grade 2 and 3 chain cable

4.3.1 For Grade 2 and 3 chain cables, mechanical test specimens required in Table 6 are to be taken from every four lengths in accordance with 4.3.2. For forged or cast chain cables where the batch size is less than four lengths, the sampling frequency will be by heat and heat treatment charge. Mechanical tests are to be carried out in the presence of the Surveyor. For the location of the test specimens see 2.3.3.3 and Figure 1. Testing is to follow 2.3.3.4 and 2.3.3.5. Retesting is to follow 2.3.3.6 and 2.3.3.7.

4.3.2 An additional link (or where the links are small, several links) for mechanical test specimen removal is (are) to be provided in a length of chain cable not containing the specimen for the breaking test. The specimen link must be manufactured and heat treated together with the length of chain cable.

# W18

(cont)

**Table 6** Number of mechanical test specimens for finished chain cables and accessories

Grade	Manufacturing method	Condition of supply <sup>1)</sup>	Number of test specimens		
			Tensile test for base metal	Charpy V-notch impact test	
				Base metal	Weldment
1	Flush-butt welded	AW N	NR	NR	NR
2	Flush-butt welded	AW	1	3	3
		N	NR	NR	NR
	Forged or Cast	N	1	3 <sup>2)</sup>	NA
3	Flush-butt welded	N NT QT	1	3	3
		N NT QT	1	3	NA

1) AW = As welded, N = Normalized, NT = Normalized and tempered, QT = Quenched and tempered  
 2) For chain cables, Charpy V-notch impact test is not required.  
 NR = Notrequired  
 NA = Not applicable

4.3.3 The mechanical properties must be in accordance with the values indicated in Table 7.

**Table 7** Mechanical properties of finished chain cables and accessories

Grade	ReH N/mm <sup>2</sup> min.	Rm N/mm <sup>2</sup>	A5 % min.	Z % min.	Charpy V-notch impact test		
					Test temperature, in °C	Absorbed energy, in Joules min.	
						Base metal	Weldment
1	NR	NR	NR	NR	NR	NR	
2	295	490-690	22	NR	0	27	27
3	410	690 min.	17	40	0 <sup>1)</sup>	60	50
					-20	35	27

<sup>1)</sup> Testing is normally to be carried out at 0°C.  
 NR = Not required.

## 4.4 Marking

Chain cables which meet the requirements are to be stamped at both ends of each length at least with the following marks; cf. Figure 3.

- Chain cable grade
- Certificate number
- Society's stamp

# W18

(cont)

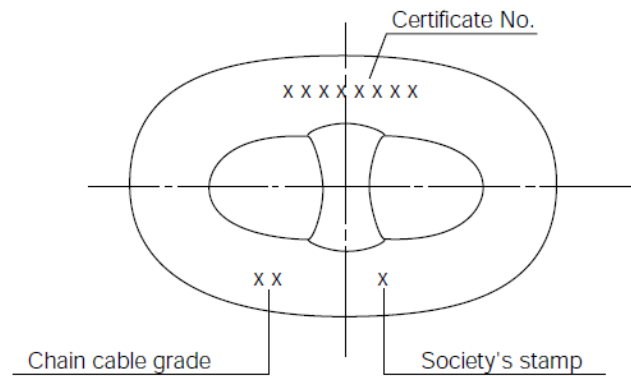

**Figure 3** Marking of chain cables

## 4.5 Certification

Chain cables which meet the requirements are to be certified by the Society at least with the following items:

- Manufacturer's name
- Grade
- Chemical composition (including total aluminum content)
- Nominal diameter/weight
- Proof/break loads
- Heat treatment
- Marks applied to chain
- Length
- Mechanical properties, where applicable

## W18.5 Testing and certification of accessories

### 5.1 Proof load test

All accessories are to be subjected to the proof load test at the proof load specified for the corresponding chain given by Table 5, and in accordance with the provisions of 4.1, as appropriate.

### 5.2 Breaking load test

5.2.1 From each manufacturing batch (same accessory type, grade, size and heat treatment charge, but not necessarily representative of each heat of steel or individual purchase order) of 25 units or less of detachable links, shackles, swivels, swivel shackles, enlarged links, and end links, and from each manufacturing batch of 50 units or less of kenter shackles, one unit is to be subjected to the breaking load test at the break load specified for the corresponding chain given by Table 5 and in accordance with the provisions of 4.1, as appropriate. Parts tested in this way may not be put to further use. Enlarged links and end links need not be tested provided that they are manufactured and heat treated together with the chain cable.

5.2.2 The Society may waive the breaking load test if:

- a) the breaking load has been demonstrated on the occasion of the approval testing of parts of the same design, and
- b) the mechanical properties of each manufacturing batch are proved, and

**W18**  
(cont)

- c) the parts are subjected to suitable non-destructive testing.

5.2.3 Notwithstanding the above, the accessories, which have been successfully tested at the prescribed breaking load appropriate to the chain, may be used in service at the discretion of the Society where the accessories are manufactured with the following:

- a) the material having higher strength characteristics than those specified for the part in question (e.g. Grade 3 material for accessories for Grade 2 chain),  
b) or alternatively, the same grade material as the chain but with increased dimensions subject to the successful procedure tests that such accessories are so designed that the breaking strength is not less than 1.4 times the prescribed breaking load of the chain for which they are intended.

### 5.3 Mechanical properties and tests

Unless otherwise specified, the forging or casting must at least comply with the mechanical properties given in Table 7, when properly heat treated. For test sampling, forgings or castings of similar dimensions originating from the same heat treatment charge and the same heat of steel are to be combined into one test unit. Mechanical tests are to be carried out in the presence of the Surveyor depending on the type and grade of material used. From each test unit, one tensile test specimen and three Charpy V-notch impact test specimens are to be taken in accordance with Table 6 and tested in accordance with UR W2. For the location of the test specimens see 2.3.3.3 and Figure 1. Testing is to follow 2.3.3.4 and 2.3.3.5. Retesting is to follow 2.3.3.6 and 2.3.3.7. Enlarged links and end links need not be tested provided that they are manufactured and heat treated together with the chain cable.

### 5.4 Marking

Accessories which meet the requirements are to be stamped as follows:

- Chain cable grade
- Certificate number
- Society's stamp

### 5.5 Certification

Chain accessories which meet the requirements are to be certified by the Society at least with the following items:

- Manufacturer's name
- Grade
- Heat Number
- Chemical composition (including total aluminum content)
- Nominal diameter/weight
- Proof/break loads
- Heat treatment
- Marks applied to accessory
- Mechanical properties, where applicable

## Appendix A

# Chafing Chain for Emergency Towing Arrangements

### 1. Scope

These requirements apply to the chafing chain for chafing gear of two types of Emergency Towing Arrangement (ETA) with specified safe working load (SWL) of 1000kN (ETA1000) and 2000kN (ETA2000). Chafing chains other than those specified can be used subject to special agreement with the Classification Society.

### 2. Approval of manufacturing

The chafing chain is to be manufactured by works approved by the Society according to W18.1.3.

### 3. Materials

The materials used for the manufacture of the chafing chain are to satisfy the requirements of W 18.2.

### 4. Design, manufacture, testing and certification of chafing chain

4.1 The chafing chain is to be designed, manufactured, tested and certified in accordance with the requirements of W18.3, W18.4 and W18.5.

4.2 The arrangement at the end connected to the strongpoint and the dimensions of the chafing chain are determined by the type of ETA. The other end of the chafing chain is to be fitted with a pear-shaped open link allowing connection to a shackle corresponding to the type of ETA and chain cable grade. A typical arrangement of this chain end is shown in Figure 1.

4.3 The common link is to be of stud link type grade 2 or 3.

4.4 The chafing chain is to be able to withstand a breaking load not less than twice the SWL. For each type of ETA, the nominal diameter of common link for chafing chains is to comply with the value indicated in Table 1.

**Table 1:** Nominal diameter of common link for chafing chains

Type of ETA	Nominal diameter of common link, d min.	
	Grade 2	Grade 3
ETA1000	62mm	52mm
ETA2000	90mm	76mm

W18  
(cont)

Figure 1: Typical outboard chafing chain end

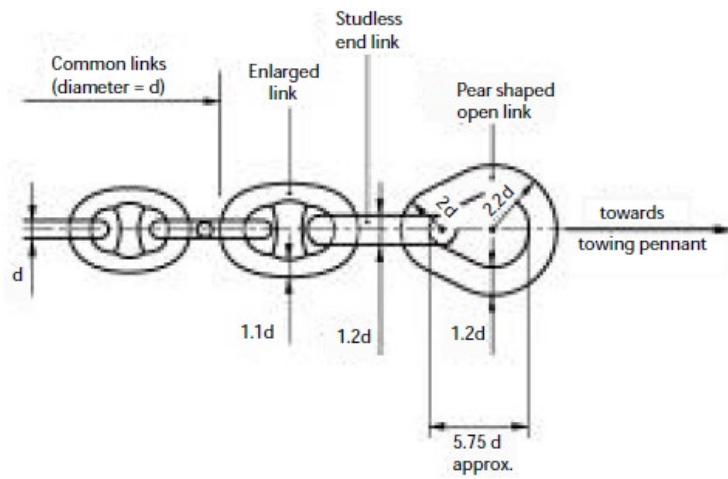

End of  
Document