

W24 Cast Copper Alloy Propellers

(1996)

(Rev.1

1997)

(Rev.2

May 2004)

(Rev.3

May 2012)

(Corr.1

Jan 2013)

(Rev.4

July 2020)

(Rev.5

Sep 2023)

1. Scope

- 1.1 These unified requirements are applicable to the manufacture, inspection and repair procedures of cast copper alloy propellers, blades and bosses.
- 1.2 Where the use of alternative alloys is proposed, particulars of chemical composition, mechanical properties and heat treatment are to be submitted for approval.
- 1.3 These requirements may also be used for the repair of propellers damaged in service, subject to prior agreement with the Classification Society.

Notes:

1. New version of this UR supersedes the IACS unified requirements nos. K1 and K2 as well as the IACS Recommendation no. 4.
2. Rev.3 of this UR is applicable to the moulding, casting, inspection and repair procedures of cast copper alloy propellers, blades and bosses from 1 July 2013.
3. Changes introduced in Rev.4 are to be uniformly implemented by IACS Societies on ships contracted for construction on or after 1 July 2021, or when the application for certification of cast copper alloy propellers is dated on or after 1 July 2021, or the application for certification of manufacturer approval is dated on or after 1 July 2021.
4. Changes introduced in Rev.5 are to be uniformly implemented by IACS Societies on ships contracted for construction on or after 1 January 2025, or when the application for certification of cast copper alloy propellers is dated on or after 1 January 2025, or the application for certification of manufacturer approval is dated on or after 1 January 2025.
5. The “contracted for construction” date means the date on which the contract to build the vessel is signed between the prospective owner and the shipbuilder. For further details regarding the date of “contract for construction”, refer to IACS Procedural Requirement (PR) No.29.

W24
(cont)**2. Foundry approval**

2.1 Approval

All propellers and propeller components are to be manufactured by foundries approved by the Classification Society. The castings are to be manufactured and tested in accordance with the requirements of these rules.

2.2 Application for approval

It is the manufacturer's responsibility to assure that effective quality, process and production controls during manufacturing are adhered to within the manufacturing specification. The manufacturing specification shall be submitted to the Classification Society at the time of initial approval, and shall at least include the following particulars: description of the foundry facilities, copper alloy material specification, runner and feeder arrangements, manufacturing procedures, non-destructive testing and repair procedures.

2.3 Scope of the approval test

The scope of the approval test is to be agreed with the Classification Society. This should include the presentation of cast test coupons of the propeller materials in question for approval testing in order to verify that the chemical composition and the mechanical properties of these materials comply with these rules.

2.4 Inspection facilities

The foundry is to have an adequately equipped laboratory, manned by experienced personnel, for the testing of moulding materials chemical analyses, mechanical testing, microstructural testing of metallic materials and non-destructive testing. Where testing activities are assigned to other companies or other laboratory, additional information required by the Society is to be included.

3. Moulding and casting

3.1 Pouring

The pouring must be carried out into dried moulds using degassed liquid metal. The pouring is to be controlled as to avoid turbulences of flow. Special devices and/or procedures must prevent slag flowing into the mould.

3.2 Stress relieving

Subsequent stress relieving heat treatment may be performed to reduce the residual stresses. For this purpose, the manufacturer shall submit a specification containing the details of the heat treatment to the Classification Society for approval. For stress relieving temperatures and holding times see tables 4 and 5.

4. Quality of castings

4.1 Freedom from defects

All castings must have a workmanlike finish and must be free from defects which would be prejudicial to their proper application in service. Minor casting defects which may still be visible after machining such as small sand and slag inclusions, small cold shuts and scabs shall be trimmed off by the manufacturer in accordance with W24.11.

W24 (cont)

4.2 Removal of defects

Casting defects which may impair the serviceability of the castings, e.g. major non-metallic inclusions, shrinkage cavities, blow holes and cracks, are not permitted. They may be removed by one of the methods described in W24.11 and repaired within the limits and restrictions for the severity zones. Full description and documentation are to be available for the surveyor.

5. Dimensions, dimensional and geometrical tolerances

5.1 The verification of dimensions, the dimensional and geometrical tolerances is the responsibility of the manufacturer.

The report on the relevant examinations is to be submitted to the Surveyor, who may require checks to be made in his presence.

5.2 Static balancing is to be carried out on all propellers in accordance with the approved drawing. Dynamic balancing is necessary for propellers running above 500 rpm.

6. Chemical composition and metallurgical characteristics

6.1 Chemical composition

Typical copper propeller alloys are grouped into the four types CU 1, CU 2, CU 3 and CU 4 depending on their chemical composition as given in table 1. Copper alloys whose chemical composition deviate from the typical values of Table 1 must be specially approved by the Classification Society.

Table 1 Typical chemical compositions of cast copper alloys for propellers

Alloy type	Cu(%)	Al(%)	Mn(%)	Zn(%)	Fe(%)	Ni(%)	Sn(%)	Pb(%)
CU1	52-62	0,5-3,0	0,5-4,0	35-40	0,5-2,5	max 1,0	max 1,5	max 0,5
CU2	50-57	0,5-2,0	1,0-4,0	33-38	0,5-2,5	3,0-8,0	max 1,5	max 0,5
CU3	77-82	7,0-11,0	0,5-4,0	max 1,0	2,0-6,0	3,0-6,0	max 0,1	max 0,03
CU4	70-80	6,5-9,0	8,0-20,0	max 6,0	2,0-5,0	1,5-3,0	max 1,0	max 0,05

The manufacturer is to maintain records of the chemical analyses of the production casts, which are to be made available to the Surveyor.

6.2 Metallurgical characteristics

Note:

"The main constituents of the microstructure in the copper-based alloys categories CU 1 and CU 2 are alpha and beta phase.

Important properties such as ductility and resistance to corrosion fatigue are strongly influenced by the relative proportion of beta phase (too high a percentage of beta phase having a negative effect on these properties). To ensure adequate cold ductility and corrosion fatigue resistance, the proportion of beta phase is to be kept low. The concept of the zinc

W24 (cont)

equivalent should be used as control since it summarizes the effect of the tendency of various chemical elements to produce beta phase in the structure."

The structure of CU 1 and CU 2 type alloys must contain an alpha phase component of at least 25 % as measured on a test bar by the manufacturer. To ensure adequate ductility and corrosion fatigue resistance, the proportion of beta phase is to be kept low. For this purpose, the zinc equivalent defined by the following formula shall not exceed a value of 45 %:

$$\text{Zinc equivalent (\%)} = 100 - \frac{100 \cdot \%Cu}{100 + A}$$

In which $A = \%Sn + 5 \times \%Al - 0,5 \times \%Mn - 0,1 \times \%Fe - 2,3 \times \%Ni$.

Note:

The negative sign in front of the elements Mn, Fe and Ni signifies that these elements tend to reduce the proportion of beta phase.

The micro structure of alloy types CU 1 and CU 2 shall be verified by determining the proportion of alpha phase. For this purpose, at least one specimen shall be taken from each heat. The proportion of alpha phase shall be determined as the average value of 5 counts.

7. Mechanical properties and tests

7.1 Standardized alloys

The mechanical properties are to comply with the values given in table 2. These values are applicable to test specimens taken from separately cast samples in accordance with Fig. 1, or with a recognized standard.

Note:

These properties are a measure of the mechanical quality of the metal in each heat; and they are generally not representative of the mechanical properties of the propeller casting itself, which may be up to 30 % lower than that of a separately cast test coupon.

For integrally cast test specimens the requirements are specially to be agreed with the Classification Society.

**Table 2 Mechanical properties of cast copper alloys for propellers
(separately cast test coupons)**

Alloy type	Proof stress $R_p 0,2$ [N/mm ²] min.	Tensile strength R_m [N/mm ²] min.	Elongation A_5 [%] min.
CU1	175	440	20
CU2	175	440	20
CU3	245	590	16
CU4	275	630	18

W24 (cont)

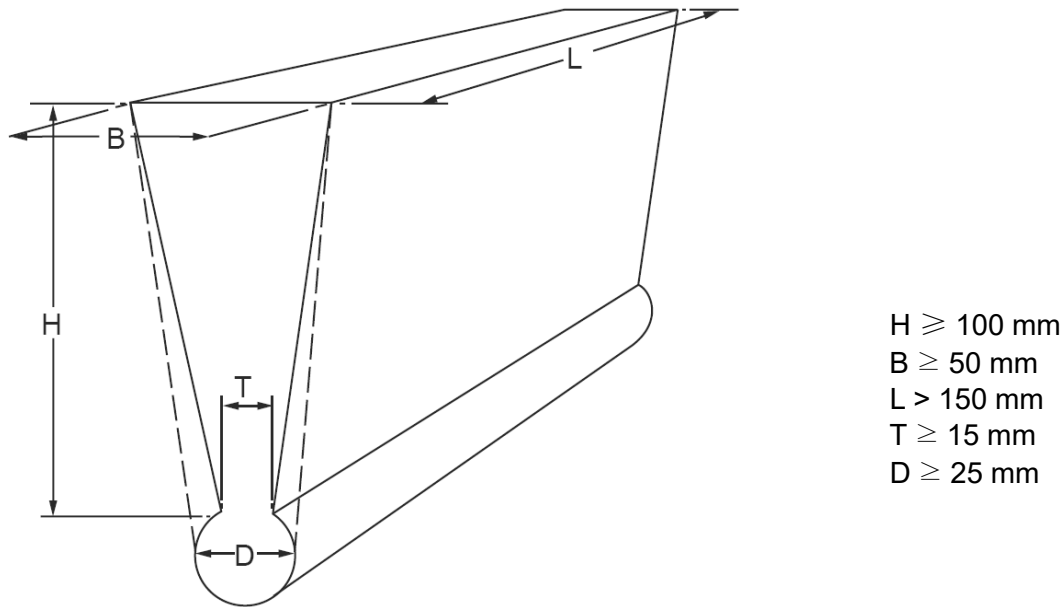

Fig.1 Test sample casting

7.2 Other alloys

The mechanical properties of alloys not meeting the minimum values of Table 2 are to comply with a specification approved by the Classification Society.

7.3 Tensile tests and specimens

Tensile tests and specimens are to be in accordance with UR W2.

Generally, the specimens shall be taken from separately cast sample pieces in accordance with W24.7.1. The test samples shall be cast in moulds made of the same material as the mould for the propeller and they must be cooled down under the same conditions as the propeller. At least one tensile test specimen shall be taken from each ladle.

If propellers are subjected to a heat treatment the test samples are to be heat treated together with them.

Where test specimens are to be taken from integrally cast test samples, this shall be the subject of special agreement with the Classification Society. Wherever possible, the test samples shall be located on the blades in an area lying between 0,5 to 0,6 R, where R is the radius of the propeller. The test sample material must be removed from the casting by non thermal procedures.

8. Definition of skew, severity zones

8.1 Definition of skew

The skew of a propeller is defined as follows:

The maximum skew angle of a propeller blade is defined as the angle, in projected view of the blade, between a line drawn through the blade tip and the shaft centreline and a second

W24 (cont)

line through the shaft centreline which acts as a tangent to the locus of the mid-points of the helical blade section, see Fig 2.

High skew propellers have a skew angle greater than 25° , low skew propellers a skew angle of up to 25° .

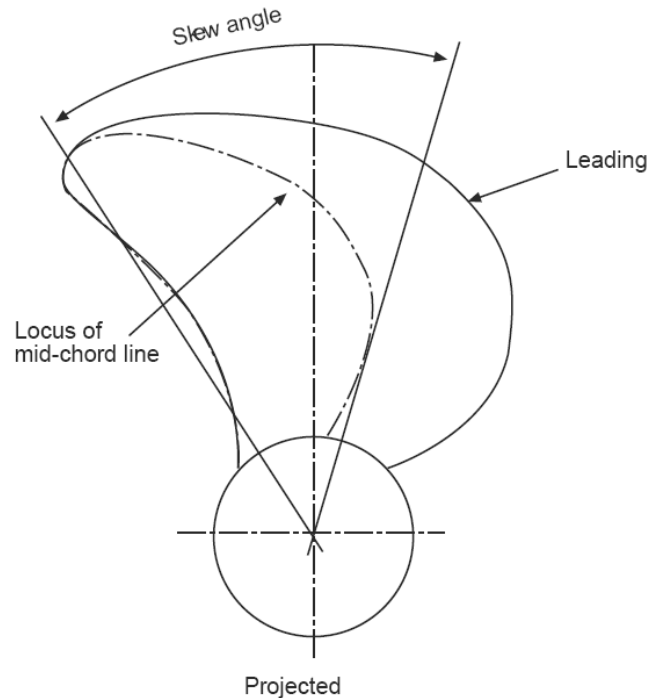

Fig.2 Definition of skew angle

8.2 Severity zones

In order to relate the degree of inspection to the criticality of defects in propeller blades and to help reduce the risk of failure by fatigue cracking after repair, propeller blades are divided into the three severity zones designated A, B and C.

Zone A is the region carrying the highest operating stresses and which, therefore, requires the highest degree of inspection. Generally, the blade thicknesses are greatest in this area giving the greatest degree of restraint in repair welds and this in turn leads to the highest residual stresses in and around any repair welds. High residual tensile stresses frequently lead to fatigue cracking during subsequent service so that relief of these stresses by heat treatment is essential for any welds made in this zone. Welding is generally not permitted in Zone A and will only be allowed after special consideration by the Classification Society. Every effort should be made to rectify a propeller which is either defective or damaged in this area without recourse to welding even to the extent of reducing the scantlings, if this is acceptable. If a repair using welding is agreed, postweld stress relief heat treatment is mandatory.

Zone B is a region where the operation stresses may be high. Welding should preferably be avoided but generally is allowed subject to prior approval from the Classification Society. Complete details of the defect / damage and the intended repair procedure are to be submitted for each instance in order to obtain such approval.

W24 (cont)

Zone C is a region in which the operation stresses are low and where the blade thicknesses are relatively small so that repair welding is safer and, if made in accordance with an approved procedure is freely permitted.

8.2.1 Low-skew propellers

Zone A is in the area on the pressure side of the blade, from and including the fillet to $0,4R$, and bounded on either side by lines at a distance $0,15$ times the chord length C_r from the leading edge and $0,2$ times C_r from the trailing edge, respectively (see Fig. 3). Where the hub radius (R_b) exceeds $0,27R$, the other boundary of zone A is to be increased to $1,5R_b$.

Zone A also includes the parts of the separate cast propeller hub which lie in the area of the windows as described in Fig. 5 and the flange and fillet area of controllable pitch and built-up propeller blades as described in Fig. 6.

Zone B is on the pressure side the remaining area up to $0,7R$ and on the suction side the area from the fillet to $0,7R$ (see Fig. 2).

Zone C is the area outside $0,7R$ on both sides of the blade. It also includes the surface of the hub of a monoblock propeller and all the surfaces of the hub of a controllable pitch propeller other than those designated Zone A above.

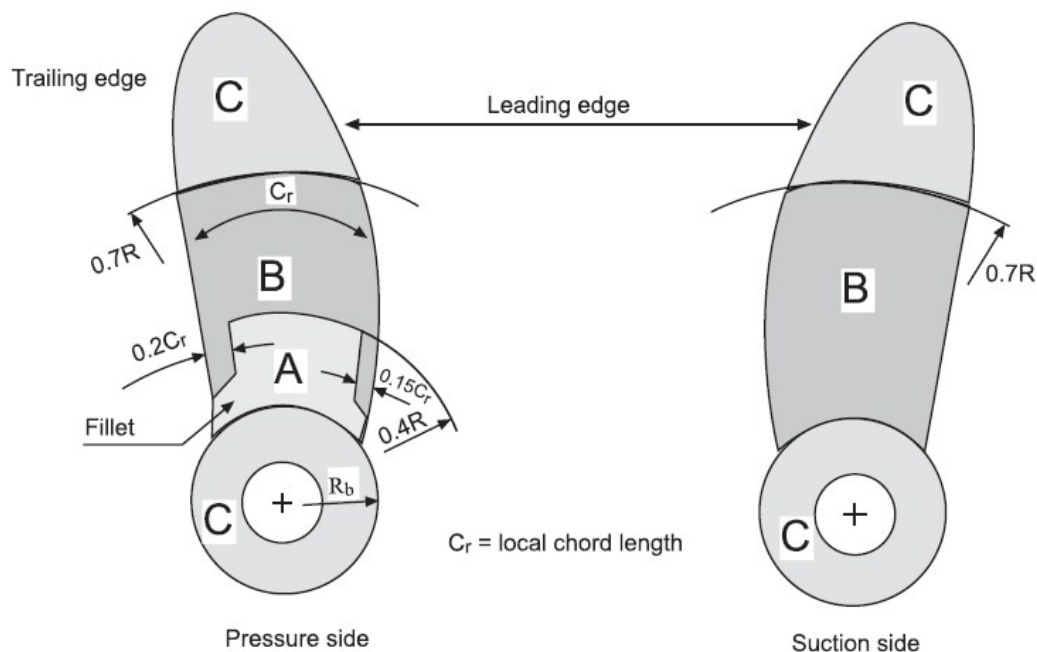

Fig.3 Severity zones for integrally cast low skew propellers

8.2.2 High-skew propellers

Zone A is the area on the pressure face contained within the blade root-fillet and a line running from the junction of the leading edge with the root fillet to the trailing edge at $0.9 R$ and at passing through the mid-point of the blade chord at $0.7 R$ and a point situated at 0.3 of the chord length from the leading edge at $0.4 R$. It also includes an area along the trailing edge on the suction side of the blade from the root to $0.9 R$ and with its inner boundary at 0.15 of the chord lengths from the trailing edge. Zone B constitutes the whole of the remaining blade surfaces. Zone A and B are illustrated in Fig. 4.

W24

(cont)

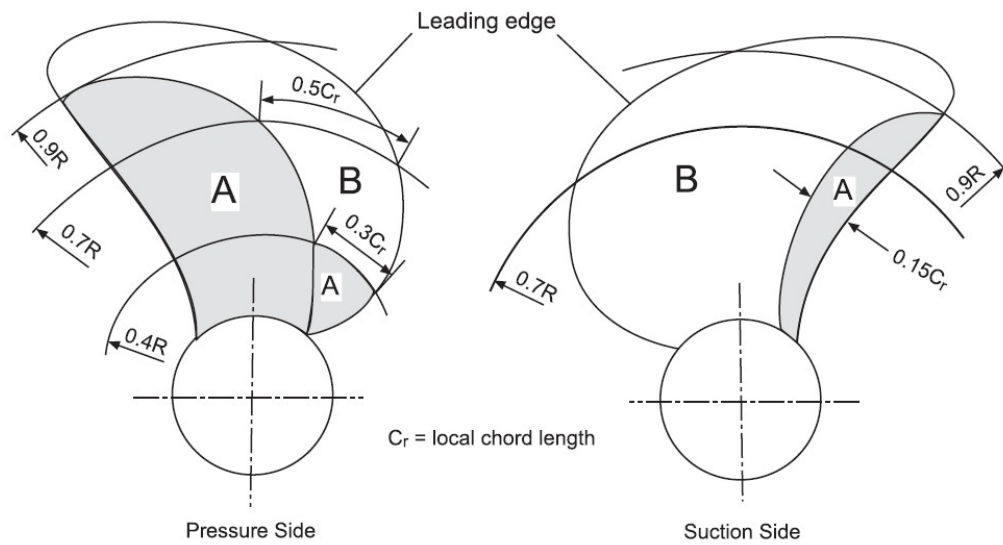

Fig.4 Severity zones in blades with skew angles greater than 25°

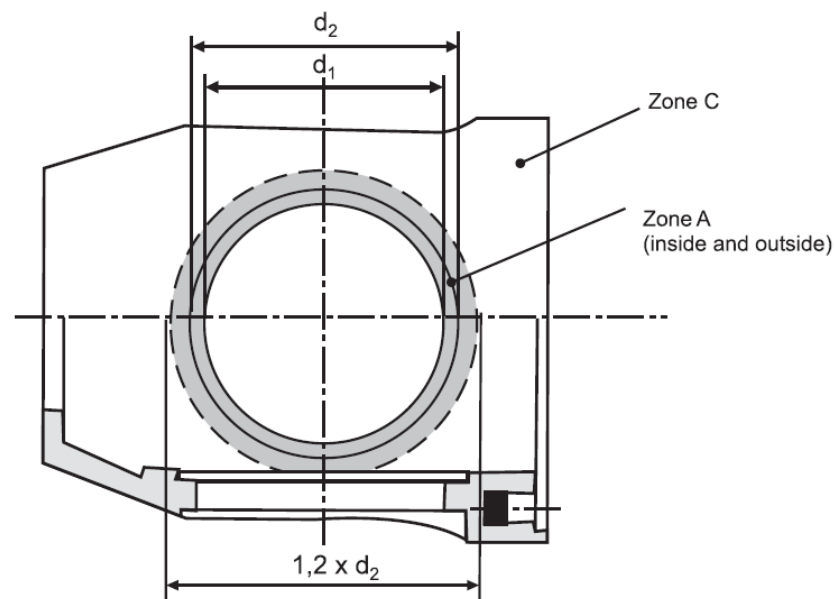

Fig.5 Severity zones for controllable pitch propeller boss

W24 (cont)

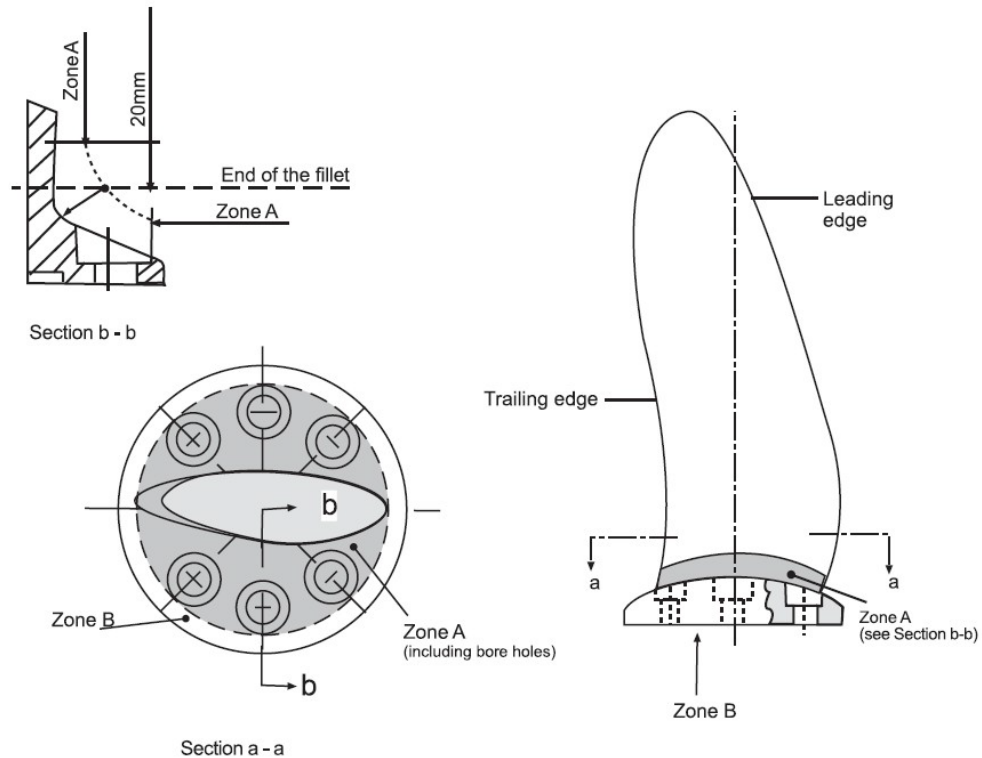

Fig.6 Severity zones for controllable pitch and built-up propeller

Note:

The remaining surface of the propeller blades is to be divided into the severity zones as given for solid cast propellers (cf. Fig. 3 and Fig. 4)

9. Non-destructive testing

9.1 Qualification of personnel involved in NDT

For the qualification of personnel refer to UR W35.

9.2 Visual testing

All finished castings are to be 100% visually inspected by the manufacturer. Castings are to be free from cracks, hot tears or other imperfections which, due to their nature, degree or extent, will interfere with the use of the castings. A general visual examination is to be carried out by the Surveyor.

9.3 Liquid penetrant testing

Liquid penetrant testing procedure is to be submitted to the Society and is to be in accordance with ISO 3452-1:2013 or a recognized standard. The acceptance criteria are specified in W24.10.

The severity zone A is to be subjected to a liquid penetrant testing in the presence of the Surveyor.

In zones B and C the liquid penetrant testing is to be performed by the manufacturer and may be witnessed by the Surveyor upon his request.

W24
(cont)

If repairs have been made either by grinding, straightening or by welding the repaired areas are additionally to be subjected to the liquid penetrant testing independent of their location and/or severity zone.

9.4 Radiographic and ultrasonic testing

When required by the Society or when deemed necessary by the manufacturer, further non-destructive testing (e.g. radiographic and/or ultrasonic testing) are to be carried out. The acceptance criteria or applied quality levels are to be agreed between the manufacturer and the Classification Society in accordance with a recognized standard.

Note: due to the attenuating effect of ultrasound within cast copper alloys, ultrasonic testing may not be practical in some cases, depending on the shape/type/thickness, and grain-growth direction of the casting.

In such cases, effective ultrasound penetration into the casting should be practically demonstrated on the item. This would normally be determined by way of back-wall reflection, and/or target features within the casting.

10. Acceptance criteria for liquid penetrant testing

10.1 Definitions of liquid penetrant indications

Indication: In the liquid penetrant testing an indication is the presence of detectable bleed-out of the penetrant liquid from the material discontinuities appearing at least 10 minutes after the developer has been applied.

Relevant indication: Only indications which have any dimension greater than 1.5mm shall be considered relevant for the categorization of indications.

Non-linear indication: indication having a length less than or equal to three times its width (i.e., $l \leq 3 w$).

Linear indication: indication having a length greater than three times its width (i.e., $l > 3 w$).

Aligned indications:

a) Non-linear indications form an alignment when the distance between indications is less than 2mm and at least three indications are aligned. An alignment of indications is considered to be a unique indication and its length is equal to the overall length of the alignment.

b) Linear indications form an alignment when the distance between two indications is smaller than the length of the longest indication.

W24

(cont)

Illustration of liquid penetrant indication is given in Fig. 7.

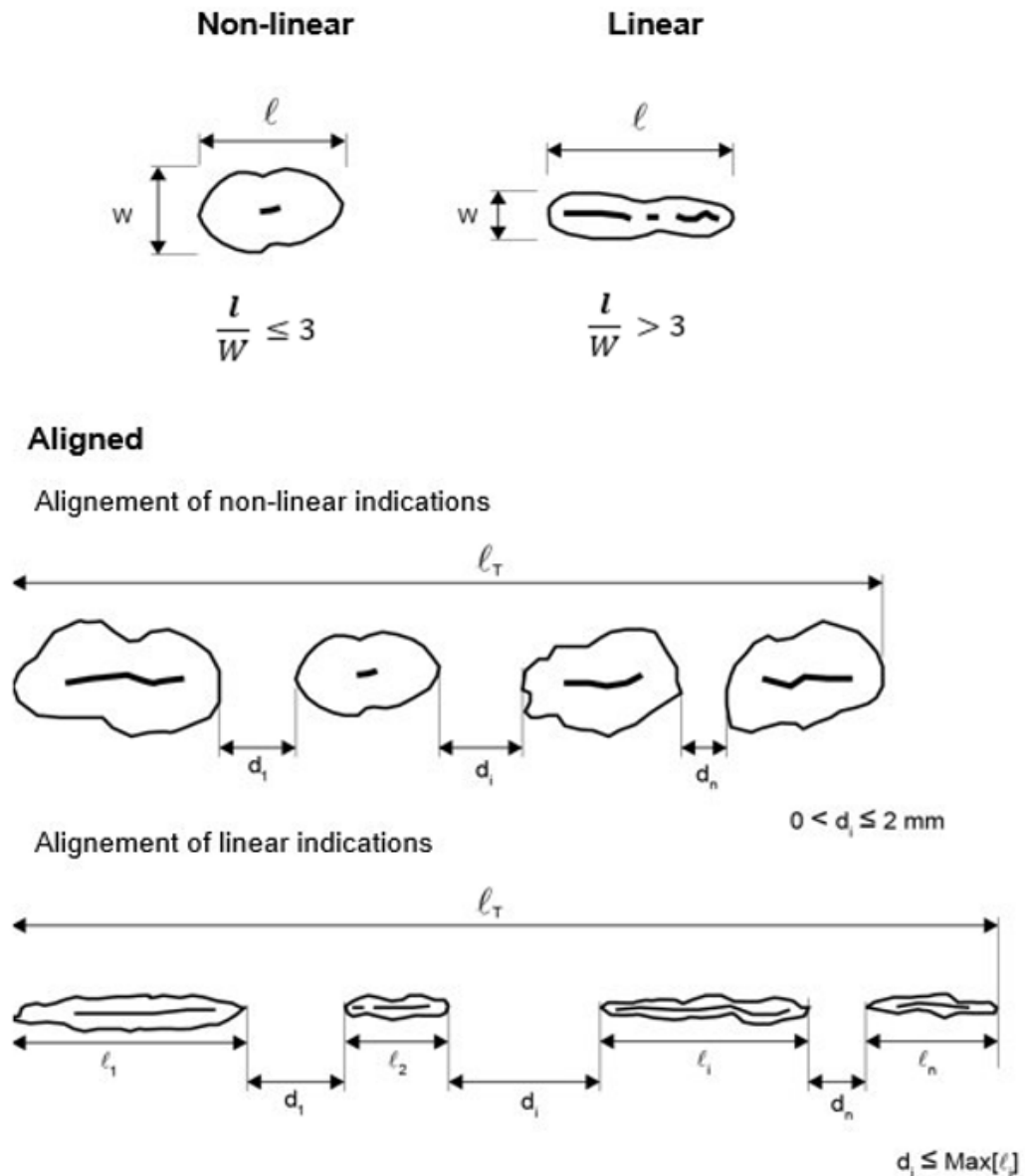

Fig.7 Shape of indications

10.2 Acceptance standard

The surface to be inspected is to be divided into reference areas of 100 cm². Each reference area may be square or rectangular with the major dimension not exceeding 250mm.

The area shall be taken in the most unfavourable location relative to the indication being evaluated.

The relevant indications detected shall, with respect to their size and number, not exceed the values given in the Table 3.

W24

(cont)

Table 3 Allowable number and size of relevant indications in a reference area of 100 cm², depending on severity zones¹⁾

Severity zones	Max. total number of indications	Type of indication	Max. number of each type ¹⁾²⁾	Max. acceptable value for "a" or "l" of indications [mm]
A	7	Non-linear	5	4
		Linear	2	3
		Aligned	2	3
B	14	Non-linear	10	6
		Linear	4	6
		Aligned	4	6
C	20	Non-linear	14	8
		Linear	6	6
		Aligned	6	6
Notes: ¹⁾ Singular non-linear indications less than 2 mm for zone A and less than 3 mm for the other zones are not considered relevant.				
²⁾ The total number of non-linear indications may be increased to the max. total number, or part thereof, represented by the absence of linear or aligned indications.				

Areas which are prepared for welding are independent of their location always to be assessed according to zone A. The same applies to the welded areas after being finished machined and/or grinded.

11. Repair of defects

11.1 Definition

Indications exceeding the acceptance standard of Table 3, cracks, shrinkage cavities, sand, slag and other non-metallic inclusions, blow holes and other discontinuities which may impair the safe service of the propeller are defined as defects and must be repaired.

11.2 Repair procedures

In general the repairs shall be carried out by mechanical means, e. g. by grinding, chipping or milling. Welding may be applied subject to the agreement of the Classification Society if the requirements of URW24.11.3, 11.4 and / or 11.5 will be complied with.

After milling or chipping grinding is to be applied for such defects which are not to be welded. Grinding is to be carried out in such a manner that the contour of the ground depression is as smooth as possible in order to avoid stress concentrations or to minimise cavitation corrosion. Complete elimination of the defective material is to be verified by liquid penetrant testing.

Welding of areas less than 5 cm² is to be avoided.

11.3 Repair of defects in zone A

In zone A, repair welding will generally not be allowed unless specially approved by the Classification Society.

W24
(cont)

Grinding may be carried out to an extent which maintains the blade thickness of the approved drawing.

The possible repair of defects which are deeper than those referred to above is to be considered by the Classification Society.

11.4 Repair of defects in zone B

Defects that are not deeper than dB (depth in zone B) = $(t/40)$ mm or 2 mm (whichever is greatest) should be removed by grinding.

Note: t = min. local thickness in mm according to the Rules of the Classification Society

Those defects that are deeper than allowable for removal by grinding may be repaired by welding.

11.5 Repair of defects in zone C

In zone C, repair welds are generally permitted.

11.6 Repair documentation

The foundry is to maintain records of inspections, welding, and any subsequent heat treatment, traceable to each casting.

Before welding is started, full details of the extent and location of the repair, the proposed welding procedure, heat treatment and subsequent inspection procedures are to be submitted to the Classification Society for approval.

12. Welding repair procedure

12.1 General

Before welding is started, manufacturer shall submit to the Classification Society a detailed welding procedure specification covering the weld preparation, welding parameters, filler metals, preheating, post weld heat treatment and inspection procedures.

All weld repairs are to be carried out in accordance with qualified procedures, and, by welders who are qualified to a recognized standard. Welding Procedure Qualification Tests are to be carried out in accordance with Appendix A and witnessed by the Surveyor.

12.2 Preparation of welding repair

Defects to be repaired by welding are to be ground to sound material according to W24.11.2.

The welding grooves are to be prepared in such a manner which will allow a good fusion of the groove bottom.

The resulting ground areas are to be examined in the presence of the Surveyor by liquid penetrant testing in order to verify the complete elimination of defective material.

W24 (cont)

12.3 Welding repair procedure

Metal arc welding is to be used for all types of welding repair on cast copper alloy propellers.

Arc welding with coated electrodes and gas-shielded metal arc process (GMAW) are generally to be applied. Argon-shielded tungsten welding (GTAW) should be used with care due to the higher specific heat input of this process. Recommended filler metals, pre-heating and stress relieving temperatures are listed in Table 4.

All propeller alloys are generally to be welded in down-hand (flat) position. Where this cannot be done, gas-shielded metal arc welding should be carried out.

The section to be welded is to be clean and dry. Flux-coated electrodes are to be dried before welding according to the maker's instructions.

To minimize distortion and the risk of cracking, interpass temperatures are to be kept low. This is especially the case with CU 3 alloys.

Slag, undercuts and other defects are to be removed before depositing the next run.

All welding work is to be carried out preferably in the shop free from draughts and influence of the weather.

With the exception of alloy CU 3 (Ni-Al-bronze) all weld repairs are to be stress relief heat treated, in order to avoid stress corrosion cracking. However, stress relief heat treatment of alloy CU 3 propeller castings may be required after major repairs in zone B (and specially approved welding in Zone A) or if a welding consumable susceptible to stress corrosion cracking is used. In such cases the propeller is to be either stress relief heat treated in the temperature 450 to 500°C or annealed in the temperature range 650-800°C, depending on the extent of repair, c. f. Table 4.

The soaking times for stress relief heat treatment of copper alloy propellers should be in accordance with Table 5. The heating and cooling is to be carried out slowly under controlled conditions. The cooling rate after any stress relieving heat treatment shall not exceed 50°C/h until the temperature of 200°C is reached.

Table 4 Recommended filler metals and heat treatments

Alloy type	Filler metal	Preheat temperature °C [min]	Interpass temperature °C [max]	Stress relief temperature °C	Hot straightening temperature °C
CU1	Al-bronze ¹⁾ Mn-bronze	150	300	350-500	500-800
CU2	Al-bronze Ni-Mn-bronze	150	300	350-550	500-800
CU3	Al-bronze Ni-Al-bronze ²⁾ Mn-Al-bronze	50	250	450-500	700-900
CU4	Mn-Al-bronze	100	300	450-600	700-850
Notes:	¹⁾ Ni-Al-bronze and Mn-Al-bronze are acceptable. ²⁾ Stress relieving not required, if filler metal Ni-Al-bronze is used.				

W24

(cont)

Table 5 Soaking times for stress relief heat treatment of copper alloy propellers

Stress relief temperature [°C]	Alloy grade CU1 and CU2		Alloy grade CU3 and CU4	
	Hours per 25 mm thickness	Max. recommended total time hours	Hours per 25 mm thickness	Max. recommended total time hours
350	5	15	-	-
400	1	5	-	-
450	1/2	2	5	15
500	1/4	1	1	5
550	1/4 ¹⁾	1/2 ¹⁾	1/2 ²⁾	2 ²⁾
600	-	-	1/4 ²⁾	1 ²⁾

Note: 1) 550°C only applicable for CU 2 alloys.
2) 550°C and 600°C only applicable for CU 4 alloys.

13. Straightening

13.1 Application of load

For hot and cold straightening purposes, static loading only is to be used.

13.2 Hot straightening

Weld repaired areas may be subject to hot straightening, provided it can be demonstrated that weld properties are not impaired by the hot straightening operations.

Straightening of a bent propeller blade or a pitch modification should be carried out after heating the bent region and approximately 500 mm wide zones on either side of it to the suggested temperature range given in Table 4.

The heating should be slow and uniform and the concentrated flames such as oxy-acetylene and oxy-propane should not be used. Sufficient time should be allowed for the temperature to become fairly uniform through the full thickness of the blade section. The temperature must be maintained within the suggested range throughout the straightening operation. A thermocouple instrument or temperature indicating crayons should be used for measuring the temperature.

13.3 Cold straightening

Cold straightening should be used for minor repairs of tips and edges only. Cold straightening on CU 1, CU 2 and CU 4 bronze should always be followed by a stress relieving heat treatment, see Table 4.

14. Identification and marking

14.1 Identifications

The manufacturer is to adopt a system for the identification of all castings, which enable the material to be traced to its original cast. The Surveyor is to be given full facilities for so tracing the castings when required.

W24
(cont)

14.2 Marking

Each finished casting propeller shall be marked by the manufacturer at least with the following particulars:

- a) Grade of cast material or corresponding abbreviated designation
- b) Manufacturer's mark
- c) Heat number, casting number or another identification mark enabling the manufacturing process to be traced back
- e) Date of final inspection
- f) Number of the Society's test-certificate
- g) Ice class symbol, where applicable
- h) Skew angle for high skew propellers.

15. Manufacturer's certificates

For each casting propeller the manufacturer is to supply to the Surveyor a certificate containing the following details:

- a) Purchaser and order number
- b) Shipbuilding project number, if known
- c) Description of the casting with drawing number
- d) Diameter, number of blades, pitch, direction of turning
- e) Grade of alloy and chemical composition of each heat
- f) Heat or casting number
- g) Final weight
- h) Results of non-destructive tests and details of test procedure where applicable
- i) Portion of alpha-structure for CU 1 and CU 2 alloys
- k) Results of the mechanical tests
- l) Casting identification No.
- m) Skew angle for high skew propellers, see W24.8.1

W24 (cont)

Appendix A: Welding procedure qualification tests for repair of cast copper alloy propeller

1. General

1.1 This document gives requirements for qualification tests of welding procedures intended for the repair of cast copper alloy propellers.

1.2 For the welding procedure approval the welding procedure qualification tests are to be carried out with satisfactory results. The qualification tests are to be carried out with the same welding process, filler metal, preheating and stress-relieving treatment as those intended applied by the actual repair work. Welding procedure specification (WPS) is to refer to the test results achieved during welding procedure qualification testing.

1.3 Welding procedures qualified at a manufacturer are valid for welding in workshops under the same technical and quality management.

2. Test piece and welding of sample

2.1 The test assembly, consisting of cast samples, is to be of a size sufficient to ensure a reasonable heat distribution and according to Fig. A.1 with the minimum dimensions:

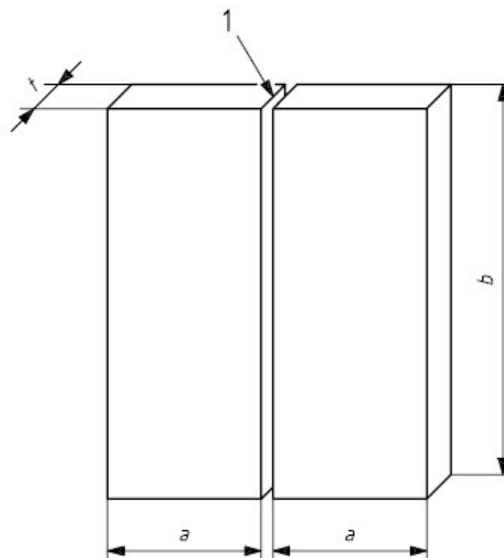

- 1: Joint preparation and fit-up as detailed in the preliminary welding procedure specification
- a: minimum value 150mm
- b: minimum value 300mm
- t: material thickness.

Fig.A.1 Test piece for welding repair procedure

A test sample of minimum 30mm thickness is to be used.

2.2 Preparation and welding of test pieces are to be carried out in accordance with the general condition of repair welding work which it represents.

2.3 Welding of the test assemblies and testing of test specimens are to be witnessed by the Surveyor.

W24

(cont)

3. Examinations and tests

3.1 Test assembly is to be examined non-destructively and destructively in accordance with the Table A.1 and Fig. A.2:

Table A.1 Type of tests and extent of testing

Type of test (1)	Extent of testing
Visual testing	100% as per article 3.2
Liquid penetrant testing	100% as per article 3.2
Transverse tensile test	Two specimens as per article 3.3
Macro examination	Three specimens as per article 3.4
Note 1: bend or fracture test are at the discretion of the Classification Society	

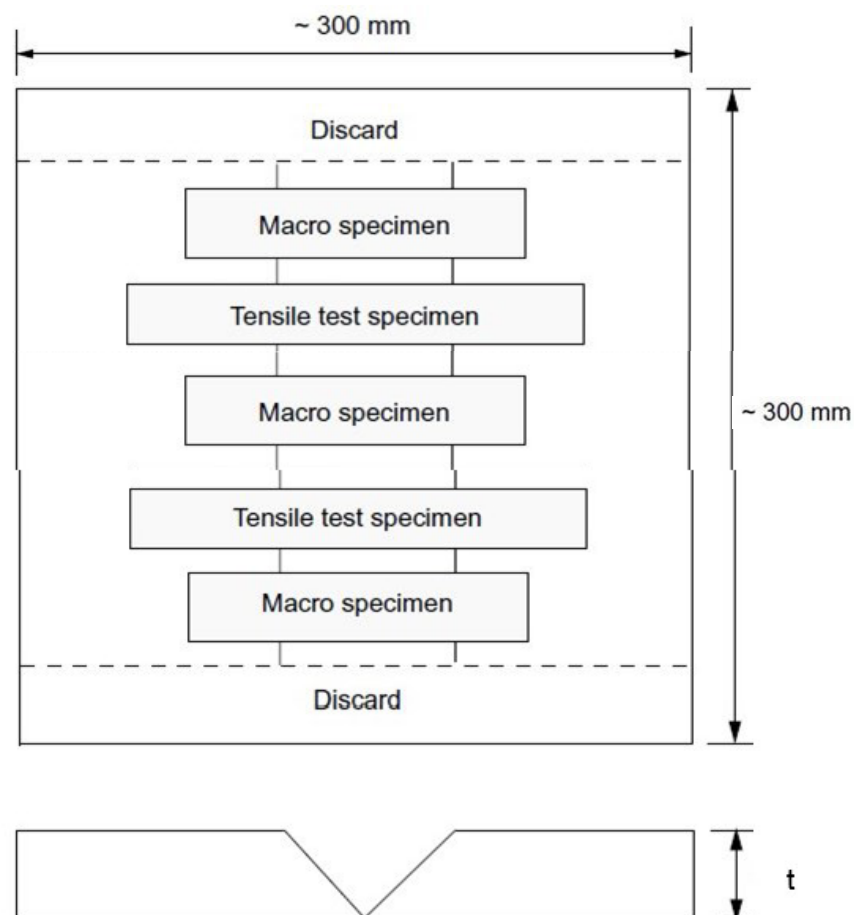

Fig.A.2 Test Specimen

3.2 Non-destructive testing

Test assembly is to be examined by visual and liquid penetrant testing prior to the cutting of test specimen. In case, that any post-weld heat treatment is required or specified, non-destructive testing is to be performed after heat treatment.

W24 (cont)

No cracks are permitted. Imperfections detected by liquid penetrant testing are to be assessed in accordance with W24.10.

3.3 Tensile test:

Two tensile tests are to be prepared as shown in UR W2 2.4.2.8 b). Alternatively tensile test specimens according to recognized standards acceptable to the Classification Society may be used. The tensile strength shall meet the values given in Table A.2.

Table A.2 Required tensile strength values

Alloy Type	Tensile Strength Rm (N/mm ²) min.
CU1	370
CU2	410
CU3	500
CU4	550

3.4 Macroscopic examination

Three test specimens are to be prepared and etched on one side to clearly reveal the weld metal, the fusion line and the heat affected zone (see Fig. 9).

A suitable etchant for this purpose is:

5 g iron (III) chloride
30 ml hydrochloric acid (cone)
100 ml water.

The test specimens are to be examined for imperfections present in the weld metal and the heat affected zone. Cracks and lack of fusion are not permitted. Imperfections such as pores, or slag inclusions, greater than 3 mm are not permitted.

3.5 Re-testing

If the test piece fails to comply with any of the requirements of this Appendix, reference is made to re-test procedures given in UR W28.

4. Test record

4.1 Welding conditions for test assemblies and test results are to be recorded in welding procedure qualification record. Forms of welding procedure qualification records can be taken from the Society's rules or from relevant standards.

4.2 A statement of the results of assessing each test piece, including repeat tests, is to be made for each welding procedure qualification records. The relevant items listed for the WPS are to be included.

W24 (cont)

4.3 The welding procedure qualification record is to be signed by the Surveyor witnessing the test and is to include the Society's identification.

5. Range of approval

5.1 General

All the conditions of validity stated below are to be met independently of each other. Changes outside of the ranges specified are to require a new welding procedure test.

A qualification of a WPS obtained by a manufacturer is valid for welding in workshops or sites under the same technical and quality control of that manufacturer.

5.2 Base metal

The range of qualification related to base metal is given in Table A.3.

Table A.3 Range of qualification for base metal

Copper alloy material grade used for qualification	Range of approval
CU1	CU1
CU2	CU1; CU2
CU3	CU3
CU4	CU4

5.3 Thickness

The qualification of a WPS carried out on a weld assembly of thickness t is valid for the thickness range given in Table A.4.

Table A.4 Range of qualification for thickness

Thickness of the test piece, t (mm)	Range of approval
$30 \leq t$	≥ 3 mm

5.4 Welding position

Approval for a test made in any position is restricted to that position.

5.5 Welding process

5.5.1 The approval is only valid for the welding process used in the welding procedure test. Single run is not qualified by multi-run butt weld test used in this UR.

W24
(cont)

5.6 Filler metal

The approval is only valid for the filler metal used in the welding procedure test.

5.7 Heat input

The upper limit of heat input approved is 25% greater than that used in welding the test piece.
The lower limit of heat input approved is 25% lower than that used in welding the test piece.

5.8 Preheating and interpass temperature

The minimum preheating temperature is not to be less than that used in the qualification test.
The maximum interpass temperature is not to be higher than that used in the qualification test.

5.9 Post-weld heat treatment

The heat treatment used in the qualification test is to be specified in pWPS. Soaking time may be adjusted as a function of thickness.

End of Document
