

Subject

Guidelines for partially weathertight hatchway covers on board containerhips (MSC/Circ.1087)

ClassNK

Technical Information

No. TEC-0555

Date 12 December 2003

To whom it may concern

Please find attached for your information guidelines approved by IMO/MSC at its 77th session.

The items included in this MSC/Circular are not, in general, mandatory requirements.

Please note, however, that the item No. 3 (STOWAGE AND SEGREGATION OF CARGO TRANSPORT UNITS CONTAINING DANGEROUS GOODS) in the guidelines is expected to become mandatory in some States or ports on or after 1 January 2004.

Items 1 and 2 have already been incorporated into the ClassNK's "Guidance for the Survey and Construction of Steel Ships" for new ships.

If you have any questions regarding the above matter, please contact:

NIPPON KAIJI KYOKAI (ClassNK)

Material and Equipment Department, Administration Center, Head Office

Address: 4-7 Kioi-cho, Chiyoda-ku, Tokyo 102-8567, Japan

Tel.: +81-3-5226-2020

Fax: +81-3-5226-2057

E-mail: eqd@classnk.or.jp

Attachment: MSC/Circ. 1087

NOTES:

- ClassNK Technical Information is provided only for the purpose of supplying current information to its readers.
- ClassNK, its officers, employees and agents or sub-contractors do not warrant the accuracy of the information contained herein and are not liable for any loss, damage or expense sustained whatsoever by any person caused by use of or reliance on this information.
- Back numbers are available on ClassNK Internet Homepage (URL: www.classnk.or.jp).

INTERNATIONAL MARITIME ORGANIZATION
4 ALBERT EMBANKMENT
LONDON SE1 7SR

Telephone: 020 7735 7611
Fax: 020 7587 3210
Telex: 23588 IMOLDN G



IMO

E

Ref. T4/4.01

MSC/Circ.1087
18 June 2003

GUIDELINES FOR PARTIALLY WEATHERTIGHT HATCHWAY COVERS ON BOARD CONTAINERSHIPS

1 The Maritime Safety Committee, at its seventy-seventh session (28 May to 6 June 2003), recognizing the need to standardize the conditions for the fitting of partially weathertight hatchway covers on containerships and to develop recommendations on installation of such covers on containerships, and having considered proposals by the forty-fifth session of the Sub-Committee on Stability and Load Lines and on Fishing Vessels Safety (SLF), the seventh session of the Sub-Committee on Dangerous Goods, Solid Cargoes and Containers (DSC) and the forty-seventh session of the Sub-Committee on Fire Protection (FP), approved the Guidelines for partially weathertight hatchway covers on board containerships, as set out in the annex.

2 Member Governments are invited to bring the annexed Guidelines to all the parties concerned for their application, as appropriate, urging them, in particular, to apply the measures for construction and equipment contained in sections 1 and 2 of the Guidelines to ships constructed on or after 1 January 2004 and to implement the operational measures contained in section 3 of the Guidelines as soon as possible for all ships.

ANNEX

**GUIDELINES FOR PARTIALLY WEATHERTIGHT
HATCHWAY COVERS ON BOARD CONTAINERSHIPS****1 LOCATION OF HATCHWAYS, HEIGHT OF COAMINGS AND WEATHERTIGHTNESS OF HATCHWAY COVERS****1.1 Introduction**

Requirements relating to the height of coamings and to the weathertightness of hatchway covers located above the superstructure deck are left to the discretion of the Administration, pursuant to regulation 14(2) of the International Convention on Load Lines (LL), 1966. This section of the Guidelines is intended to serve as a guide when decisions are made on whether to accept partially weathertight hatchway covers on board containerships, in accordance with regulation 14(2) of the 1966 LL Convention.

1.2 Design considerations and criteria

1.2.1 Coamings and hatchway covers to exposed hatchways situated above the second superstructure tier or its equivalent, or above the third tier or its equivalent, in the forward quarter of the ship's length, may be regarded as being situated above the superstructure deck, for the purpose of giving effect to regulation 14(2) of the 1966 LL Convention. Partially weathertight hatch covers fitted to hatchways situated in such locations may be accepted subject to the following conditions.

1.2.2 Coamings and hatchway covers may be fitted to hatchways located on exposed decks situated at least two standard superstructure heights above the actual freeboard deck or an assumed freeboard deck, on the basis of which a calculation of the freeboard may be made corresponding to the draught, which should be not less than that which would correspond to the freeboard actually assigned to the ship. If any part of the hatchway is forward of a point located a quarter of a ship's length (0.25L) from the forward perpendicular, this hatchway should be located on an exposed deck which is situated at least three standard superstructure heights above the actual or assumed freeboard. It should be noted that use is made of a notional freeboard deck solely for the purpose of measuring the height of the deck on which hatchways are located; it may consist of an imaginary or a virtual deck which, under such circumstances, is not used for the actual assignment of the freeboard. The freeboard of the ship should be assigned on the basis of an actual deck, referred to as the *freeboard deck*, which should be determined in accordance with the provisions of the 1966 LL Convention and of IACS Unified Interpretation LL39, as contained in LL.3/Circ.77.

1.2.3 The height of the hatchway coamings should not be less than 600 mm.

1.2.4 Non-weathertight gaps between the hatchway covers should be regarded as unprotected openings with respect to the requirements relating to intact stability and damage stability calculations. The gaps should also be as small as possible and proportional to the capacity of the bilge pumping system and the estimated amount of water penetration, as well as to the capacity and the operational efficiency of the fire-extinguishing system, and in any case should be not more than 50 mm.

1.2.5 Labyrinths, gutters or other equivalent means should be fitted close to the edges of each hatch cover at right angles with the openings in order to reduce to a minimum the quantity of water that might penetrate into the hold from the upper surface of each cover. Figures 1.2.5-1 and 1.2.5-2 are examples of labyrinth and gutter arrangements.

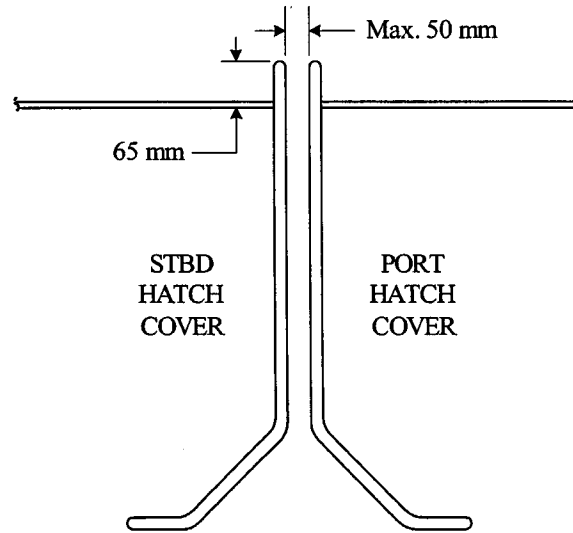

INTERFACE BETWEEN PORT AND STARBOARD HATCH COVERS
(LOOKING AFT)

Figure 1.2.5-1

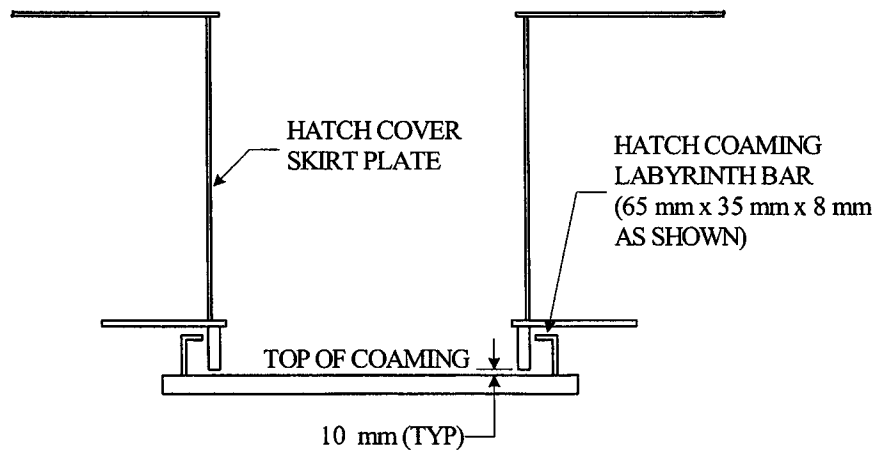

HATCH COVER INTERFACE WITH HATCH COAMING LABYRINTH BAR
(LOOKING INBOARD)

Figure 1.2.5-2

1.2.6 Scantlings for hatchway covers and the components of clamping devices used to secure the covers to the structure supporting them and the coamings, should be at the very least equivalent to those applying to weathertight hatchway covers and be in accordance with the relevant provisions of a recognized organization¹ or with the appropriate national standards established by the Administration and which provide for an equivalent level of safety.

2 INCREASE OF CARBON DIOXIDE FIRE-EXTINGUISHING MEDIA FOR FIXED GAS FIRE-EXTINGUISHING SYSTEMS

2.1 Introduction

This section of the Guidelines is intended to serve as a guide when decisions are made on whether to accept partially weathertight hatchway covers on board containerships in accordance with SOLAS regulations II-2/10.7.1.1 and II-2/20.6.1.1, and the relevant provisions of the Fire Safety Systems Code (chapter 5, paragraph 2.2.1.1), taking into account the leakage of carbon dioxide fire-extinguishing media through clear gaps between hatchway covers.

2.2 Increase of carbon dioxide fire-extinguishing media

If a container cargo hold fitted with partially weathertight hatchway covers is protected by a fixed carbon dioxide fire-extinguishing system, the amount of carbon dioxide for the cargo space should be increased in accordance with one of the following formulae, as appropriate:

$$CO_2^{INC}_{30\%} = 60 \cdot A_T \cdot \sqrt{\frac{B}{2}} \quad (2.2 - 1)$$

$$CO_2^{INC}_{45\%} = 4 \cdot A_T \cdot \sqrt{\frac{B}{2}} \quad (2.2 - 2)$$

where:

$CO_2^{INC}_{30\%}$: increase of carbon dioxide for cargo spaces not intended for carriage of motor vehicles with fuel in their tanks for their own propulsion (kg);

$CO_2^{INC}_{45\%}$: increase of carbon dioxide for cargo spaces intended for carriage of motor vehicles with fuel in their tanks for their own propulsion (kg);

A_T : total maximum area of clear gaps (m²); and

B : breadth of cargo space protected by the carbon dioxide fire-extinguishing systems (m).

¹ Recognized organization means an organization that has been recognized in accordance with SOLAS regulation XI/1.

3 STOWAGE AND SEGREGATION OF CARGO TRANSPORT UNITS CONTAINING DANGEROUS GOODS

3.1 Introduction

This section of the Guidelines is intended to serve as a guide when decisions are made on the stowage and segregation of cargo transport units (CTUs) containing dangerous goods on containerships fitted with partially weathertight hatchway covers. For the purpose of the stowage and segregation of CTUs containing dangerous goods on containerships fitted with partially weathertight hatchway covers, the effect of clear gaps, as defined below, should be taken into consideration. The effects of other structures such as labyrinths are not considered, as no clear path exists into the hold.

3.2 Definitions

For the purpose of the application of this section of the Guidelines:

- .1 "clear gap" means a clear unobstructed passage between hatchway covers that provides a path for dangerous goods to enter the cargo hold;
- .2 "effective gutterbar" means a gutterbar the height of which is not less than 50 mm and also includes labyrinth bar; and
- .3 "sensitive vertical line" means a vertical line under deck within one container space from a clear gap in athwartships direction(s) as specified by "C" in figures 3.2.3-1 and 3.2.3-2 below or equivalent.

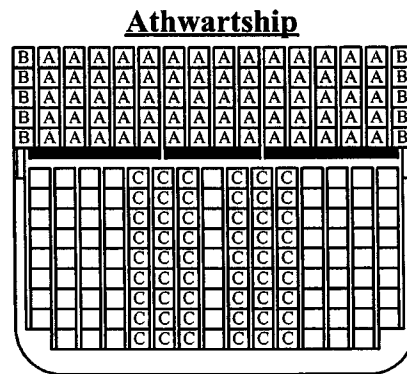
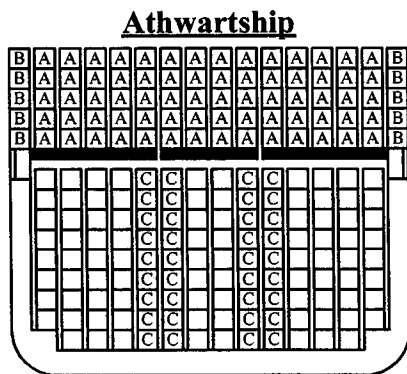

Figure 3.2.3-1-Illustration of vertical lines Figure 3.2.3-2-Illustration of vertical lines

Note: Vertical row positions "on-deck", not directly above clear gaps between hatchway covers, are specified by "A". Vertical row positions with less than 50% footing on the hatch, are specified by "B". Where containers are placed in the outermost vertical row positions with more than 50% footing on the hatch cover are deemed to qualify as position(s) "A".

3.3 Partially weathertight hatchway covers fitted with effective gutterbars

Partially weathertight hatchway covers fitted with effective gutterbars can be regarded as "resistant to fire and liquid" for the purposes of stowage and segregation of CTUs containing dangerous goods on containerhips fitted with such hatchway covers. Therefore, no special provision, other than those set out in paragraph 3.4, applies to the stowage and segregation of CTUs containing dangerous goods on or under the hatchway covers fitted with effective gutterbars. Gutterbars showing any visible structural damage, which would reduce their effectiveness, do not meet the definition in paragraph 3.2.2.

3.4 Special requirement for "on-deck" stowage

3.4.1 Prohibition of stowage directly above clear gaps

CTUs containing dangerous goods should not be stowed in the vertical lines specified by "X" in figure 3.4.1, above cargo holds fitted with partially weathertight hatchway covers having a clear gap, unless the cargo hold complies with the relevant requirements for the class and flash point of the dangerous goods in SOLAS regulation II-2/19. When "not in the same vertical line unless separated by a deck" is required in the IMDG Code and CTUs containing dangerous goods are stowed in position "X", as shown in figure 3.4.1 below, CTUs containing incompatible dangerous goods should not be stowed under deck in vertical lines indicated by "C" in figures 3.2.3-1 or 3.2.3-2.

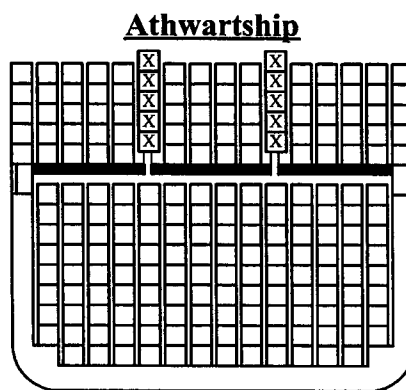

Figure 3.4.1 - Illustration of prohibited stowage of dangerous goods

3.4.2 Special requirement for on deck stowage of CTUs above hatchway covers without effective gutterbars

Where hatchway covers are not fitted with effective gutterbars, CTUs containing dangerous goods should not be stowed in the vertical lines specified by "A" in figures 3.2.3-1 and 3.2.3-2, above cargo holds fitted with partially weathertight hatchway covers, unless the cargo hold complies with the relevant requirements for the class and flash point of the dangerous goods in SOLAS regulation II-2/19.

3.4.3 *On deck stowage of CTUs above cargo hold with effective gutterbars*

Where hatchway covers are fitted with effective gutterbars, CTUs containing dangerous goods can be stowed in all vertical lines specified by "A" and "B" in figures 3.2.3-1 and 3.2.3-2 except as provided in paragraph 3.4.1, above cargo holds fitted with partially weathertight hatchway covers, regardless of whether the cargo hold under the hatchway cover complies with the relevant requirements in SOLAS regulation II-2/19.

3.5 *Special requirement for segregation*

3.5.1 *Special requirement for segregation and stowage of CTUs on partially weathertight hatchway covers without effective gutterbars*

Where "not in the same vertical line unless separated by a deck" is required in the IMDG Code, the following applies:

- .1 when the reference CTU is stowed on deck in positions specified by "A" in figures 3.2.3-1 and 3.2.3-2, CTUs containing incompatible dangerous goods should not be stowed within the relevant sensitive vertical lines under deck. Examples are illustrated in figures 3.5.1-1 and 3.5.1-2; and
- .2 when the reference CTU is stowed under deck in positions as specified by "C" in figures 3.2.3-1 and 3.2.3-2, CTUs containing incompatible dangerous goods should not be stowed on the hatches above the hold. Example is illustrated in figure 3.5.1-3.

3.5.2 *Segregation of CTUs related to hatchway covers with effective gutterbars*

Where hatchway covers are fitted with effective gutterbars, segregation of CTUs containing dangerous goods on board containerhips should be in accordance with the segregation requirements in paragraph 7.2.3.2 of the IMDG Code for containerhips.

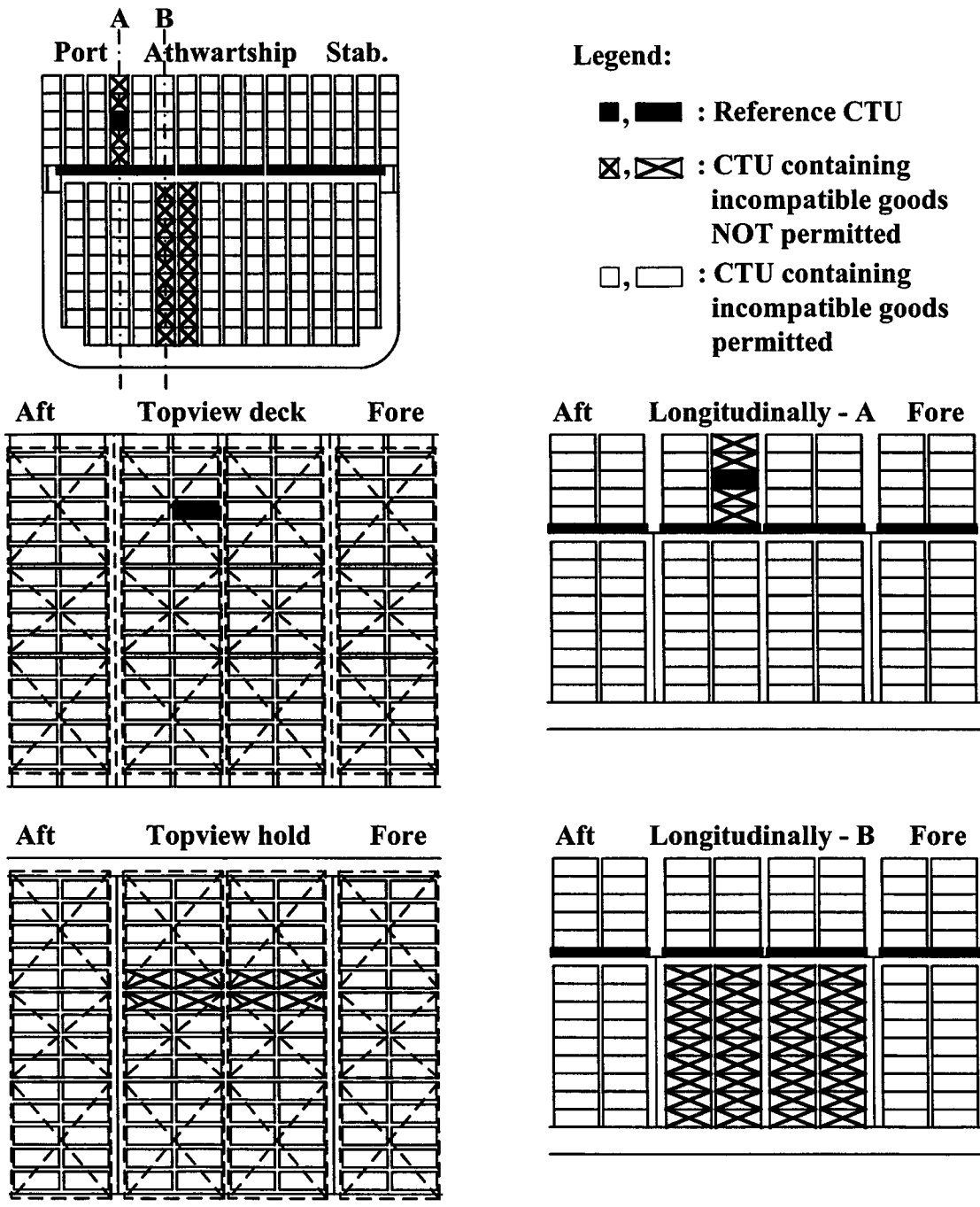
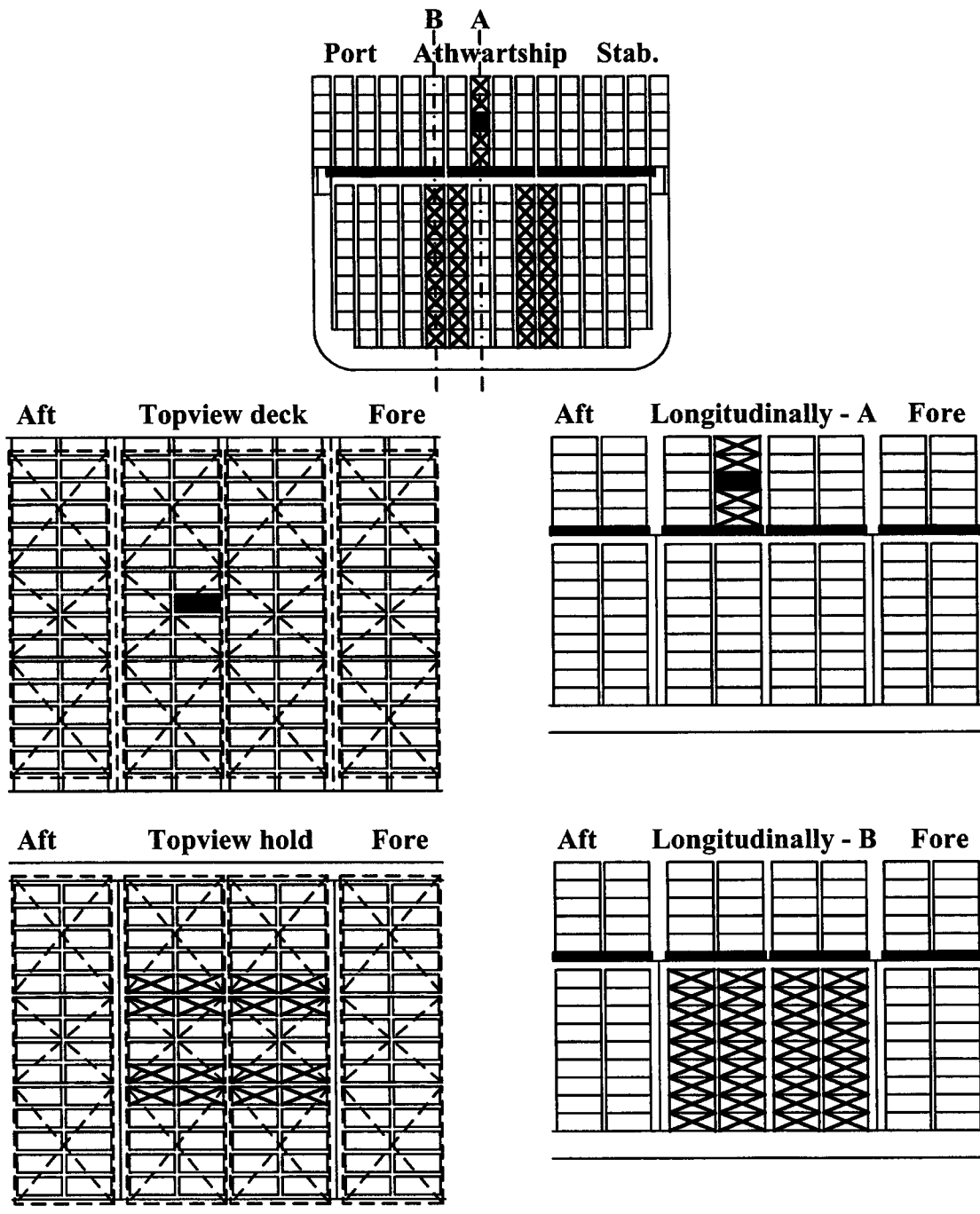

Figure 3.5.1-1 - Example of segregation within sensitive vertical lines (reference CTU is above left hatchway cover)



**Figure 3.5.1-2 - Example of segregation within sensitive vertical lines
(reference CTU is above centre hatchway covers)**

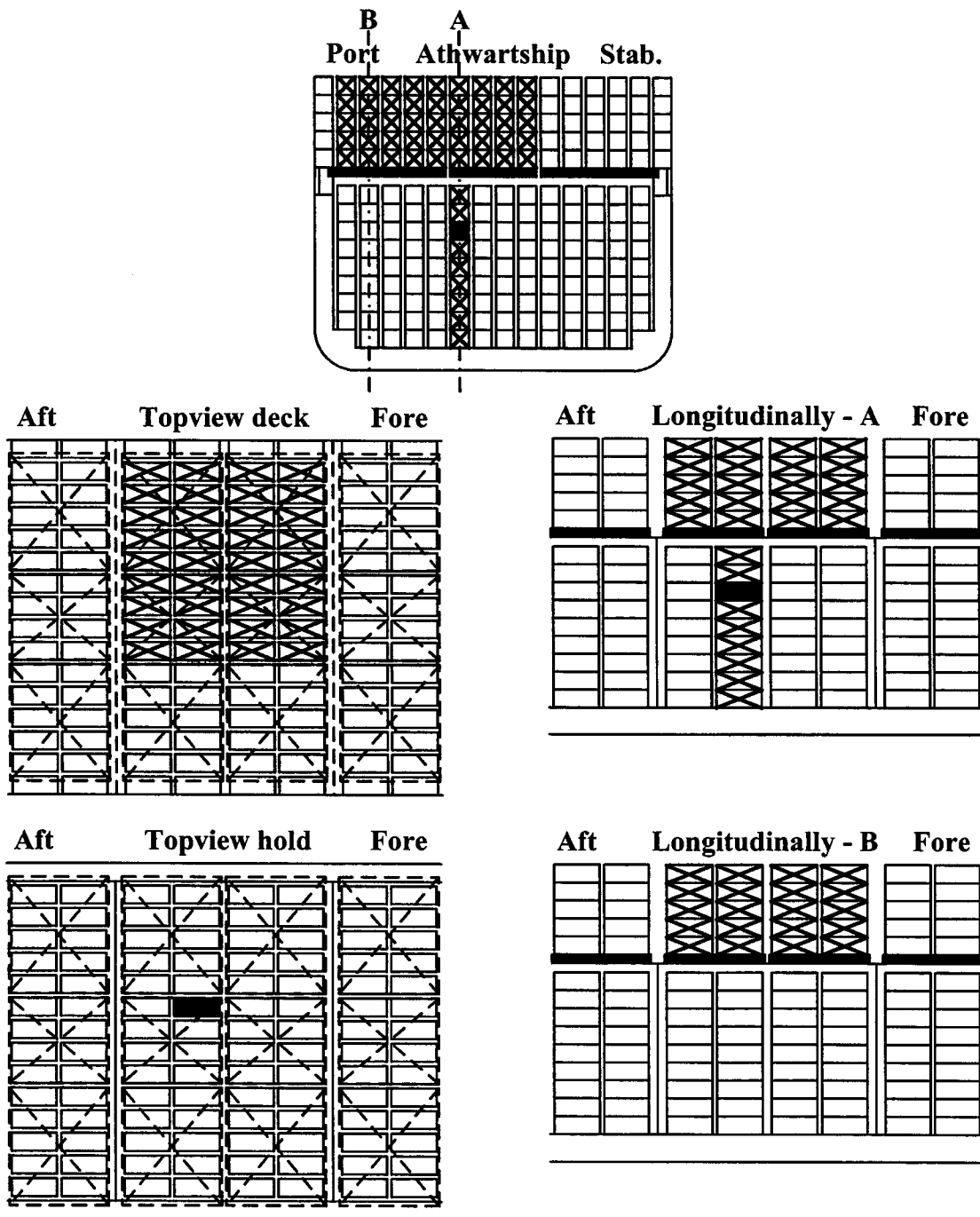

Figure 3.5.1-3 – Example of segregation within sensitive vertical lines
(reference CTU is in sensitive vertical line under deck)