

Subject

Amendments to the Finnish-Swedish Ice Class Rules

ClassNK

Technical Information

No. TEC-0701
Date 8 June 2007

To whom it may concern

Amendment to the Finnish-Swedish Ice Class Rules entered in force on 1 January 2007.

Amendments have been made in section 1 (General) and section 2 (Ice class draught). For ships assigned ice class IA, IB or IC (Class IA Super, IA, IB or IC defined in Chapter 28 of our rules) and built on or after 1 July 2007, if the summer load line in fresh water is located at a higher level than the UIWL (Upper Ice Water Line), a “warning triangle” and an “ice class draught mark” at the maximum permissible ice class draught amidships are to be provided with the ship’s sides. Ships built before 1 July 2007 shall be provided with such marking not later than the first scheduled dry docking after 1 July 2007.

This amendment was adopted on 19 December 2006 and entered in force on 1 January 2007.

For any questions about the above, please contact:

NIPPON KAIJI KYOKAI (ClassNK)
Survey Department, Administration Center, Head Office
Address: 4-7 Kioi-cho, Chiyoda-ku, Tokyo 102-8567, Japan
Tel.: +81-3-5226-2027
Fax: +81-3-5226-2029
E-mail: svd@classnk.or.jp

Attachment: Amendments to the Finnish-Swedish ice class rules

NOTES:

- ClassNK Technical Information is provided only for the purpose of supplying current information to its readers.
- ClassNK, its officers, employees and agents or sub-contractors do not warrant the accuracy of the information contained herein and are not liable for any loss, damage or expense sustained whatsoever by any person caused by use of or reliance on this information.
- Back numbers are available on ClassNK Internet Homepage (URL: www.classnk.or.jp).



AMENDMENTS TO THE FINNISH-SWEDISH ICE CLASS RULES

The Finnish Maritime Administration has, on 19 December 2006, adopted amendments to the regulations of 20 September 2002 on the structural design and engine output required of ships for navigation in ice (No. 5/30/2002).

The attached amendments to the regulations enter into force on 1 January 2007.

Amendments have been made in section 1 (General) and section 2 (Ice class draught). The descriptions of the ice classes in section 1 are amended in accordance with section 3 of the Act on the Ice Classes of Ships and Icebreaker Assistance (1121/2005). This amendment does not have any effect on the technical content of the rules.

In section 2, the ice class draughts i.e. the upper and lower ice waterlines at which the ship is to be strengthened for navigation in ice are defined. This allows a ship to be strengthened at a lower waterline than that at which the ship is allowed to sail in open water. In that case the deepest waterline at which the ship is intended to operate in ice has to be marked on the ship's sides as given in the rules. The draught of a ship must not exceed the maximum permissible ice class draught when the ship is sailing to or from a Finnish port where assistance restrictions requiring as a minimum ice class IC, IB or IA of ships are in force.

If the ship's draught exceeds the maximum permissible ice class draught when the ship is sailing to or from a Finnish port where assistance restrictions require as a minimum ice class IC, IB or IA of ships, the Finnish Maritime Administration may redetermine the ship's ice class under section 8 of the Act on the Ice Classes of Ships and Icebreaker Assistance. It is also noteworthy that a ship is overloaded when its draught exceeds the maximum permissible ice class draught, which under Chapter 20(1) of the Maritime Act (674/1994) may be liable to penalty.

Director of Maritime Safety

Paavo Wihuri

Senior Maritime Inspector

Jorma Kämäräinen

This Bulletin
supersedes Bulletin:

13/1.10.2002 in part

No. 2476/30/2006
ISSN 1455-9048

**FINNISH MARITIME
ADMINISTRATION****REGULATION****Date: 19.12.2006
No. 2476/30/2006**

- Contents: Regulations on the structural design and engine output required of ships for navigation in ice (description of ice classes, ice class draught)
- Based on: Act on the Ice Classes of Ships and Icebreaker Assistance (1121/2005), section 4(1)
- Period of validity: January 1, 2007 – until further notice
- Repeals: Finnish Maritime Administration regulations on the structural design and engine output required of ships for navigation in ice, section 1 (General) and section 2 (Ice class draught) 20.9.2002 (No. 5/30/2002)

**FINNISH MARITIME ADMINISTRATION
REGULATIONS
ON THE AMENDMENTS OF THE FINNISH MARITIME ADMINISTRATION
REGULATIONS ON THE STRUCTURAL DESIGN AND ENGINE OUTPUT REQUIRED
OF SHIPS FOR NAVIGATION IN ICE**

Adopted in Helsinki on 19 December 2006

Under section 4(1) of the Act of 22 December 2005 on the Ice Classes of Ships and Icebreaker Assistance (1121/2005) the Finnish Maritime Administration has decided the following:

Section 1

The Finnish Maritime Administration has amended section 1 (General) and section 2 (Ice class draught) in the Finnish Maritime Administration regulations of 20 September 2002 on the structural design and engine output required of ships for navigation in ice (No. 5/30/2002). The amendments are attached to this regulation.

Section 2

The draught of a ship must not exceed the maximum permissible ice class draught when the ship is sailing to or from a Finnish port where assistance restrictions requiring as a minimum ice class IC, IB or IA of the ships are in force.

Section 3

The maximum and minimum ice class draught fore, amidships and aft and the required engine output shall be indicated in the classification certificate not later than the renewal of the classification certificate on 1 July 2007 or later.

Section 4

These regulations enter into force on 1 January 2007.

These regulations repeal section 1 (General) and section 2 (Ice class draught) of the Finnish Maritime Administration regulations of 20 September 2002 on the structural design and engine output required of ships for navigation in ice (No. 5/30/2002).

These regulations apply to all ships irrespective of their year of build.

Helsinki, 19 December 2006

Director-General

Markku Mylly

Director of Maritime Safety

Paavo Wihuri

**FINNISH MARITIME ADMINISTRATION
REGULATIONS
ON THE AMENDMENT OF THE FINNISH MARITIME ADMINISTRATION
REGULATIONS ON THE STRUCTURAL DESIGN AND ENGINE OUTPUT REQUIRED
OF SHIPS FOR NAVIGATION IN ICE**

“FINNISH-SWEDISH ICE CLASS RULES”

Adopted in Helsinki on 19 December 2006 (No. 2476/30/2006)

The Finnish Maritime Administration has decided to *amend* section 1 (General) and section 2 (Ice class draught) of the Finnish Maritime Administration regulations of 20 September 2002 on the structural design and engine output required of ships for navigation in ice (No. 5/30/2002), and *add* an Annex III to section 2 (Ice class draught) as follows:

1 GENERAL

1.1 Ice classes

Under section 3 of the Act on the Ice Classes of Ships and Icebreaker Assistance (1121/2005) ships are assigned to ice classes as follows:

1. ice class IA Super; ships with such structure, engine output and other properties that they are normally capable of navigating in difficult ice conditions without the assistance of icebreakers;
2. ice class IA; ships with such structure, engine output and other properties that they are capable of navigating in difficult ice conditions, with the assistance of icebreakers when necessary;
3. ice class IB; ships with such structure, engine output and other properties that they are capable of navigating in moderate ice conditions, with the assistance of icebreakers when necessary;
4. ice class IC; ships with such structure, engine output and other properties that they are capable of navigating in light ice conditions, with the assistance of icebreakers when necessary;
5. ice class II; ships that have a steel hull and that are structurally fit for navigation in the open sea and that, despite not being strengthened for navigation in ice, are capable of navigating in very light ice conditions with their own propulsion machinery;
6. ice class III; ships that do not belong to the ice classes referred to in paragraphs 1-5.

2 ICE CLASS DRAUGHT

2.1 Upper and lower ice waterlines

The upper ice waterline (UIWL) shall be the highest waterline at which the ship is intended to operate in ice. The line may be a broken line.

The lower ice waterline (LIWL) shall be the lowest waterline at which the ship is intended to operate in ice.

2.2 Maximum and minimum draught fore and aft

The maximum and minimum ice class draughts at fore and aft perpendiculars shall be determined in accordance with the upper and lower ice waterlines.

Restrictions on draughts when operating in ice shall be documented and kept on board readily available to the master. The maximum and minimum ice class draughts fore, amidships and aft shall be indicated in the classification certificate. For ships built on or after 1 July 2007, if the summer load line in fresh water is located at a higher level than the UIWL, the ship's sides are to be provided with a warning triangle and with an ice class draught mark at the maximum permissible ice class draught amidships (see Annex III). Ships built before 1 July 2007 shall be provided with such a marking, if the UIWL is below the summer load line, not later than the first scheduled dry docking after 1 July 2007.

The draught and trim, limited by the UIWL, must not be exceeded when the ship is navigating in ice. The salinity of the sea water along the intended route shall be taken into account when loading the ship.

The ship shall always be loaded down at least to the LIWL when navigating in ice. Any ballast tank, situated above the LIWL and needed to load down the ship to this water line, shall be equipped with devices to prevent the water from freezing. In determining the LIWL, regard shall be paid to the need for ensuring a reasonable degree of ice-going capability in ballast. The propeller shall be fully submerged, if possible entirely below the ice. The forward draught shall be at least:

$$(2 + 0.00025 \Delta) h_o \text{ [m] but need not exceed } 4h_o, \text{ where}$$

Δ = displacement of the ship [t] on the maximum ice-class draught according to 2.1.

h_o = level ice thickness [m] according to 4.2.1.

Please note that the term "LWL" shall be replaced by "UIWL" also in the following sections of the Finnish-Swedish Ice Class Rules, 2002: 3.2.2, 4.1.1, 4.3.1, 4.4.1, 4.7.1, 4.7.2, 4.8.4 and in Annex I. The term "BWL" shall be replaced by "LIWL" in the following sections: 3.2.2, 4.1.1, 4.3.1 and 4.4.1.

ANNEX III

ICE CLASS DRAUGHT MARKING

Subject to section 2.2, the ship's sides are to be provided with a warning triangle and with a draught mark at the maximum permissible ice class draught amidships (see Figure 1). The purpose of the warning triangle is to provide information on the draught limitation of the vessel when it is sailing in ice for masters of icebreakers and for inspection personnel in ports.

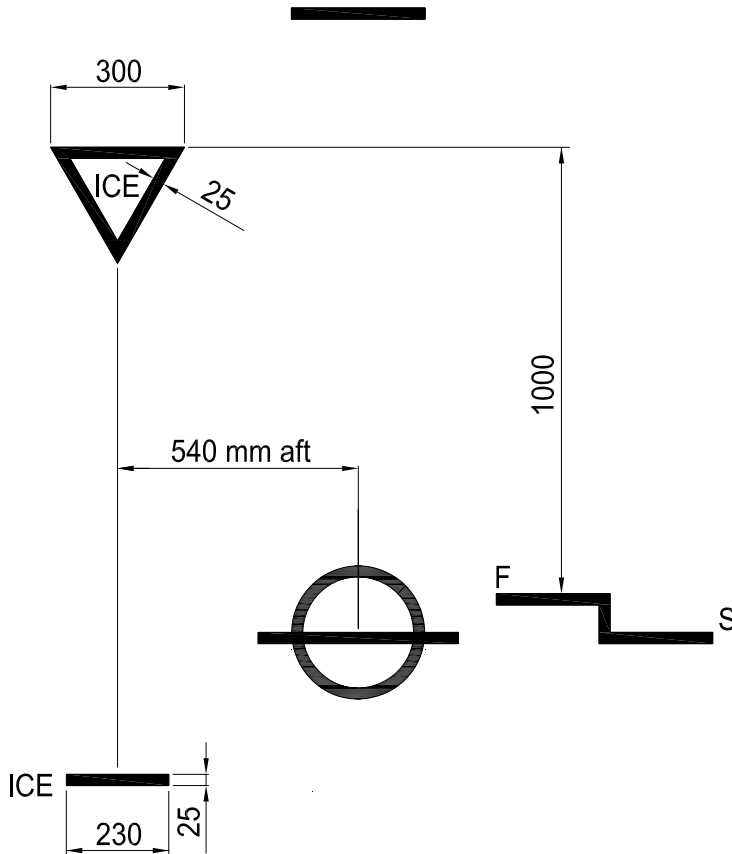

Figure 1. Ice Class Draught Marking

Notes to Figure 1

1. The upper edge of the warning triangle is to be located vertically above the "ICE" mark, 1000 mm higher than the Summer Load Line in fresh water but in no case higher than the deck line. The sides of the triangle are to be 300 mm in length.
2. The ice class draught mark is to be located 540 mm abaft the centre of the load line ring or 540 mm abaft the vertical line of the timber load line mark, if applicable.
3. The marks and figures are to be cut out of 5 - 8 mm plate and then welded to the ship's side. The marks and figures are to be painted in a red or yellow reflecting colour in order to make the marks and figures plainly visible even in ice conditions.
4. The dimensions of all figures are to be the same as those used in the load line mark.