

Subject

Load Line Mark for Vietnamese flagged vessel

ClassNK

Technical Information

No. TEC-0873

Date 11 November 2011

To whom it may concern

Vietnam Register has notified ClassNK of "Guidance for loadline mark arrangement for a Vietnamese ship whose Loadline certificate is issued by a foreign class society" as attached.

According to the Guidance, the mark of the Assigning Load Line Authority for all Vietnamese flagged vessels for which ClassNK has issued an International Load Line Certificate must be changed from "NK" to "VR and NK" by the following surveys:

1. For vessels with keels laid on or after 1 November 2011: Initial survey for International Load Line Certificate.
2. For vessels with keels laid before 1 November 2011: Periodical docking survey or first renewal survey for International Load Line Certificate after 1st November 2011, whichever occurs first.

For any questions about the above, please contact:

NIPPON KAIJI KYOKAI (ClassNK)
Hull Department, Administration Center, Head Office
Address: 4-7 Kioi-cho, Chiyoda-ku, Tokyo 102-8567, Japan
Tel.: +81-3-5226-2017 / 2018
Fax: +81-3-5226-2019
E-mail: hld@classnk.or.jp

Attachment:

1. Guidance for loadline mark arrangement for a Vietnamese ship whose Loadline certificate is issued by a foreign class society

NOTES:

- ClassNK Technical Information is provided only for the purpose of supplying current information to its readers.
- ClassNK, its officers, employees and agents or sub-contractors do not warrant the accuracy of the information contained herein and are not liable for any loss, damage or expense sustained whatsoever by any person caused by use of or reliance on this information.
- Back numbers are available on ClassNK Internet Homepage (URL: www.classnk.or.jp).



CỤC ĐĂNG KIỂM VIỆT NAM
VIETNAM REGISTER

ĐỊA CHỈ: 18 PHẠM HÙNG, HÀ NỘI
ADDRESS: 18 PHAM HUNG ROAD, HA NOI
DIỆN THOẠI/ TEL: +84 4 3 7684701
FAX: +84 4 3 7684779
EMAIL: vr-id@vr.org.vn
WEB SITE: www.vr.org.vn

THÔNG BÁO KỸ THUẬT TÀU BIỂN
TECHNICAL INFORMATION ON SEA-GOING SHIPS

Date: 25 October 2011

Ref. Number: 039TIE/11TB

Subject: VR's Letter reference number 16/DN2011/loadline/nG dated 13 October 2011 relating to "Guidance for loadline mark arrangements for a Vietnamese ship whose Loadline certificate is issued by a foreign class society".

To: Ship Builders/ Ship Repairers
Ship Design Companies
Shipping Companies
VR's Ship Survey Offices

We would like to send you attached with VR's Letter reference number 16/DN2011/loadline/nG dated 13 October 2011 relating to "Guidance for loadline mark arrangements for a Vietnamese ship whose Loadline certificate is issued by a foreign class society".

The concerned parties are kindly requested to apply the above-mentioned Guideline in the due course.

This Technical Information is available at item: *VR Notice/ Sea-going Ships Technical Information* on VR's website: <http://www.vr.org.vn>.

If you need any further information relating to the above issue, please contact:

Vietnam Register
Sea-going Ship Classification and Registry Department
Address: 18 Pham Hung Road, Tu Liem District, Ha Noi City
Tel: +84 4 37684701 (ext.: 530)
Fax: +84 4 37684722
email: bangph@vr.org.vn

Yours faithfully,

Nguyen Vu Hai
Vice General Director
For and on behalf of the General Director

From: Trinh Ngoc Giao
General Director

Sub: Guidance for loadline mark arrangements for a Vietnamese ship whose Loadline certificate is issued by a foreign class society.

Our ref: *16* /DN2011/loadline/nG

Hanoi, 13th October 2011

To Whom it may concern

This is referred to the paragraph 2.3.2-2(2), Part 11 of the “Rules for Classification and Construction of sea-going steel ships” of QCVN 21: 2010/BGTVT, on the arrangements of the loadline marks for a Vietnamese sea-going ship whose International Loadline Certificate is issued by a foreign class society on the authorization of Vietnam register (VR). In addition to the loadlines and other characters, the loadline marks consist of four letters that indicate the authority of loadlines assignment to a ship. Among the four letters, the letters of VR are affixed on the left of the circle, the other two letters which indicates the foreign class society who issues the International Loadline Certificate to the ship is affixed on the right of the circle. The four letters are on above the line, which goes transversely through the circle center point. The two letters that indicate the foreign class society are the abbreviations of the name of that society and normally affixed on the ship loadlines according to its related regulations and guidance.

The circle, loadlines and letters are to be painted white or yellow on dark ground or painted black on light ground.

For a ship of metal, the circle, loadlines and letters are to be at least 8mm in thickness. The material of the circle, loadlines and letters is to be of the same material of the ship hull and continuously welded on to each shipside.

Please, see in the Attachment the details for illustrated loadline marks arrangements.

The effective date of the above-mentioned regulation is as follows:

1/ Ship with keel laid on or after 1st November 2011: Before the related International Loadline Certificate is issued.

2/ Ship with keel laid before 1st November 2011: At the periodical docking survey or at the first International Loadline Certificate renewal survey after 1st November 2011, whichever is sooner.

Foreign class societies who are authorized by VR for the survey and issuance of the International Loadline Certificate are to be responsible for supervision of the welding of loadline marks on to shipside and any necessary changes of the International Loadline Certificate to be issued for compliance with the above-mentioned regulation. Such foreign class societies are to forward to VR a copy of the International Loadline Certificate that has been issued by them.

Please, feel free to contact the undersigned if you need any clarification.

Sincerely Yours,



Trinh Ngoc Giao
General Director

Attachment: The details for loadline marks arrangements

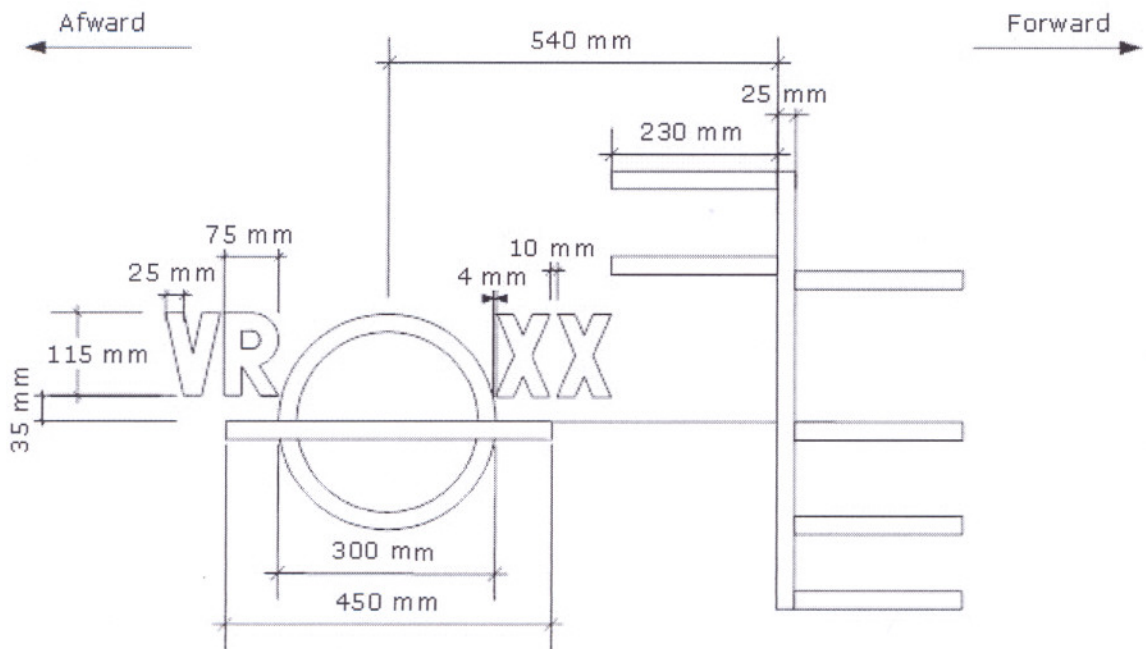

(XX: The two letters that indicate foreign class society are the abbreviations of the name of that society)