

Contents

RULES FOR THE SURVEY AND CONSTRUCTION OF STEEL SHIPS	3
Part I SHIPS OPERATING IN POLAR WATERS, POLAR CLASS SHIPS AND ICE CLASS SHIPS	3
Chapter 1 GENERAL.....	3
1.1 General.....	3
1.2 Definitions	4
1.3 Performance Standards (<i>Polar Code</i> , Part I-A, 1.4).....	7
1.4 Sources of Hazards (with reference to <i>Polar Code</i> , INTRODUCTION, 3)	7
1.5 Operational Assessment (<i>Polar Code</i> , Part I-A, 1.5).....	8
Chapter 2 POLAR WATER OPERATIONAL MANUAL (PWOM)	9
2.1 Goal (<i>Polar Code</i> , Part I-A, 2.1)	9
2.2 Functional Requirements (<i>Polar Code</i> , Part I-A, 2.2)	9
2.3 Regulations (<i>Polar Code</i> , Part I-A, 2.3).....	9
Chapter 3 SHIP STRUCTURE.....	11
3.1 Goal (<i>Polar Code</i> , Part I-A, 3.1)	11
3.2 Functional Requirements (<i>Polar Code</i> , Part I-A, 3.2)	11
3.3 Regulations (<i>Polar Code</i> , Part I-A, 3.3).....	11
Chapter 4 SUBDIVISION AND STABILITY	12
4.1 Goal (<i>Polar Code</i> , Part I-A, 4.1)	12
4.2 Functional Requirements (<i>Polar Code</i> , Part I-A, 4.2)	12
4.3 Regulations (<i>Polar Code</i> , Part I-A, 4.3).....	12
Chapter 5 WATERTIGHT AND WEATHERTIGHT INTEGRITY	13
5.1 Goal (<i>Polar Code</i> , Part I-A, 5.1)	13
5.2 Functional Requirements (<i>Polar Code</i> , Part I-A, 5.2)	13
5.3 Regulations (<i>Polar Code</i> , Part I-A, 5.3).....	13
Chapter 6 MACHINERY INSTALLATIONS	14
6.1 Goal (<i>Polar Code</i> , Part I-A, 6.1)	14
6.2 Functional Requirements (<i>Polar Code</i> , Part I-A, 6.2)	14
6.3 Regulations (<i>Polar Code</i> , Part I-A, 6.3).....	14
Chapter 7 FIRE SAFETY/PROTECTION.....	16
7.1 Goal (<i>Polar Code</i> , Part I-A, 7.1)	16
7.2 Functional Requirements (<i>Polar Code</i> , Part I-A, 7.2)	16
7.3 Regulations (<i>Polar Code</i> , Part I-A, 7.3).....	16
Chapter 8 ICE CLASS SHIPS	18
8.1 General.....	18
8.2 Design Ice Pressures	19
8.3 Hull Structures and Equipment	22
8.4 Fundamental Requirements of Machinery.....	29
8.5 Design Loads of Propulsion Units (Ice Classes <i>IA Super</i> , <i>IA</i> , <i>IB</i> and <i>IC</i>)	32

8.6	Design of Propellers and Propulsion Shafting Systems (Ice Classes <i>IA Super</i> , <i>IA</i> , <i>IB</i> and <i>IC</i>)	45
8.7	Alternative Design	53
8.8	Design of Propulsion Units (Ice Class <i>ID</i>).....	53
8.9	Miscellaneous Machinery Requirements.....	54
ANNEX 1	SPECIAL REQUIREMENTS FOR THE MATERIALS, HULL STRUCTURES, EQUIPMENT AND MACHINERY OF POLAR CLASS SHIPS	55
Chapter 1	GENERAL.....	55
1.1	General.....	55
1.2	Definitions	55
Chapter 2	MATERIALS AND WELDING	61
2.1	Material.....	61
2.2	Welding.....	65
2.3	Corrosion/Abrasion Additions.....	65
Chapter 3	HULL STRUCTURE	67
3.1	Application.....	67
3.2	Subdivision and Stability	67
3.3	Design Ice Load.....	68
3.4	Local Strength	72
3.5	Longitudinal Strength.....	79
Chapter 4	MACHINERY INSTALLATIONS	82
4.1	General.....	82
4.2	Materials	82
4.3	Definitions	83
4.4	Design Loads.....	87
4.5	Design.....	102
4.6	Prime Movers.....	114
4.7	Fastening Loading Accelerations	114
4.8	Auxiliary Systems and Piping Systems	115
4.9	Ventilation System	116
4.10	Rudders and Steering Arrangements	116
4.11	Alternative Design	117

RULES FOR THE SURVEY AND CONSTRUCTION OF STEEL SHIPS

Part I SHIPS OPERATING IN POLAR WATERS, POLAR CLASS SHIPS AND ICE CLASS SHIPS

Chapter 1 GENERAL

1.1 General

1.1.1 Application

1 The requirements in this Part apply to ships intended for navigation in polar waters or ice-infested waters.

2 The materials, hull structures, equipment, machinery, etc. of ships operating in polar waters are to be in accordance with the requirements in **Chapter 1** to **Chapter 7** of this Part in addition to those in other Parts as well as the **Rules for Marine Pollution Prevention Systems, Rules for Safety Equipment** and **Rules for Radio Installations** relevant to such ships.

3 Notwithstanding the provision in **-2** above, ships corresponding to following **(1)** or **(2)** need not comply with the requirements in **Chapter 1** and **Chapter 7** of this Part.

(1) Ships not subject to the *SOLAS* convention in accordance with *SOLAS Chapter I*; and

(2) Ships owned or operated by the flag administration and used for non-commercial purposes.

4 Ships intended for independent navigation in ice-infested polar waters (hereinafter referred to as “polar class ship” in this Part), are to comply with **Annex 1** “**Special Requirements for the Materials, Hull Structures, Equipment and Machinery of Polar Class Ships**” in addition to requirements in other parts.

5 Where a ship is intended to be registered as an ice class vessel (hereinafter referred to as “ice class ship” in this Part) for navigation of the Northern Baltic complying with the *Finnish-Swedish Ice Class Rules* or in the Canadian Arctic complying with the *Arctic Shipping Safety and Pollution Prevention Regulations*, the materials, hull structures, equipment and machinery of the ship are to be in accordance with the requirements in **Chapter 1** except for **1.3** to **1.5** and **Chapter 8** of this Part in addition to those in other Parts.

1.1.2 Documentation*

1 The polar class defined in **1.2.1(20)** or the ice class defined in **1.2.2(1)** is to be indicated in the general arrangement, midship section, arrangements to resist panting in both peaks and their vicinity, shell expansion and plan of propeller specified in **Table B2.1, Part B**.

2 For polar class ships, the upper ice waterline specified in **1.2.1(23)**, the lower ice waterline specified in **1.2.1(24)** and hull area specified in **1.2.3** of **Annex 1** “**Special Requirements for the Materials, Hull Structures, Equipment and Machinery of Polar Class Ships**” are to be indicated in the shell expansion specified in **Table B2.1, Part B**. The corrosion/abrasion additions specified in **2.3** of **Annex 1** “**Special Requirements for the Materials, Hull Structures, Equipment and Machinery of Polar Class Ships**” are to be indicated in the midship section, arrangements of both peaks and shell expansion.

3 For ice class ships, the upper ice water line specified in **1.2.1(23)**, the lower ice waterline specified in **1.2.1(24)**, hull area specified in **1.2.2(2)**, the engine output defined in **8.4.2**, the displacement defined in **8.1.2-6** and the dimensions necessary for the engine output calculation required in **8.4.2** are to be indicated in the shell expansion specified in **Table B2.1, Part B**.

1.1.3 Precautions Regarding Low Temperatures

The low temperature of the ship’s ambience is to be considered for designing structures, equipment and arrangements essential for the safety and operation of the ship, e.g. the functioning of hydraulic systems, hazard of freezing of water piping and tanks, starting of emergency reciprocating internal combustion engines, etc.

1.1.4 Equivalency

1 Alternative hull construction, equipment, etc. which does not fall under the provisions of **Chapters 3, 6 and 7** of this Part will be accepted by the Society, provided that such construction, equipment, etc. is considered to be equivalent to that required by this Part in accordance with *SOLAS Chapter XIV Regulation 4*.

2 Alternative hull construction, equipment, etc. which does not fall under the provisions of **Chapter 8** of this Part will be accepted by the Society, provided that the Society is satisfied that such construction, equipment, etc. is considered to be equivalent to that required by **Chapter 8** of this Part

1.2 Definitions

1.2.1 Terms*

The definitions of terms which appear in this Part are to be as specified in the following (1) to (27), unless specified elsewhere.

- (1) "Category A ship" is a ship designed for operation in polar waters in at least medium first-year ice, which may include old ice inclusions.
- (2) "Category B ship" is a ship not included in category A, designed for operation in polar waters in at least thin first-year ice, which may include old ice inclusions.
- (3) "Category C ship" is a ship designed to operate in open water or in ice conditions less severe than those included in categories A and B.
- (4) "First-year ice" is sea ice of not more than one winter growth developing from young ice with thickness from 0.3 m to 2.0 m.
- (5) "Ice free waters" is no ice present. If ice of any kind is present this term is not to be used.
- (6) "Ice of land origin" is ice formed on land or in an ice shelf, found floating in water.
- (7) "Medium first-year ice" is first-year ice of 70 cm to 120 cm thickness.
- (8) "Old ice" is sea ice which has survived at least one summer's melt; typical thickness up to 3 m or more. It is subdivided into residual first-year ice, second-year ice and multi-year ice.
- (9) "Open water" is a large area of freely navigable water in which sea ice is present in concentrations less than 1/10. No ice of land origin is present.
- (10) "Sea ice" is any form of ice found at sea which has originated from the freezing of sea water.
- (11) "Thin first-year ice" is first-year ice 30 cm to 70 cm thick.
- (12) "Bergy waters" is an area of freely navigable water in which ice of land origin is present in concentrations less than 1/10. There may be sea ice present, although the total concentration of all ice is not to exceed 1/10.
- (13) "Escort ship" is any ship with superior ice capability in transit with another ship.
- (14) "Escorted operation" is any operation in which a ship's movement is facilitated through the intervention of an escort.
- (15) "Habitable environment" is a ventilated environment that will protect against hypothermia.
- (16) "Icebreaker" is any ship whose operational profile may include escort or ice management functions, whose powering and dimensions allow it to undertake aggressive operations in ice-covered waters.
- (17) "Maximum expected time of rescue" is the time adopted for the design of equipment and system that provide survival support. It is never to be less than 5 days.
- (18) "Machinery Installations" are equipment and machinery and its associated piping and cabling, which is necessary for the safe operation of the ship.
- (19) "Mean Daily Low Temperature" (*MDLT*) is the mean value of the daily low temperature for each day of the year over a minimum 10 year period. A data set acceptable to the Society may be used if 10 years of data is not available.
- (20) "Polar Class" (*PC*) is class notation for the ship designed to operate in ice-infested waters in accordance with **Annex 1 "Special Requirements for the Materials, Hull Structures, Equipment and Machinery of Polar Class Ships"**.
- (21) "Polar Service Temperature" (*PST*) is a temperature specified for a ship which is intended to operate in low air temperature, which is to be set at least 10°C below the lowest *MDLT* for the intended area and season of operation in polar waters.
- (22) "Ship intended to operate in low air temperature" is a ship which is intended to undertake voyages to or through areas where the lowest *MDLT* is below -10°C.
- (23) "Upper ice waterline" (*UIWL*) is defined by the maximum draughts fore, amidships and aft when sailing in ice covered waters.

- (24) “Lower ice waterline” (*LIWL*) is defined by the minimum draughts fore, amidships and aft when sailing in ice covered waters. The *LIWL* is determined with due regard to the vessel’s ice-going capability in ballast loading conditions. The propeller is to be fully submerged at the lower ice waterline.
- (25) “Polar waters” is Arctic waters and/or the Antarctic area.
- (26) “Antarctic area” is the sea area south of latitude 60° S. (see [Fig. 11.1](#))
- (27) “Arctic waters” is those waters which are located north of a line from the latitude 58°00′.0 N and longitude 042°00′.0 W to latitude 64°37′.0 N, longitude 035°27′.0 W and thence by a rhumb line to latitude 67°03′.9 N, longitude 026°33′.4 W and thence by a rhumb line to the latitude 70°49′.56 N and longitude 008°59′.61 W (Sørkapp, Jan Mayen) and by the southern shore of Jan Mayen to 73°31′.6 N and 019°01′.0 E by the Island of Bjørnøya, and thence by a great circle line to the latitude 68°38′.29 N and longitude 043°23′.08 E (Cap Kanin Nos) and hence by the northern shore of the Asian Continent eastward to the Bering Strait and thence from the Bering Strait westward to latitude 60° N as far as Il'pyskiy and following the 60th North parallel eastward as far as and including Etolin Strait and thence by the northern shore of the North American continent as far south as latitude 60° N and thence eastward along parallel of latitude 60° N, to longitude 056°37′.1 W and thence to the latitude 58°00′.0 N, longitude 042°00′.0 W. (see [Fig. 11.2](#))

Fig. 11.1 Maximum extent of Antarctic area application

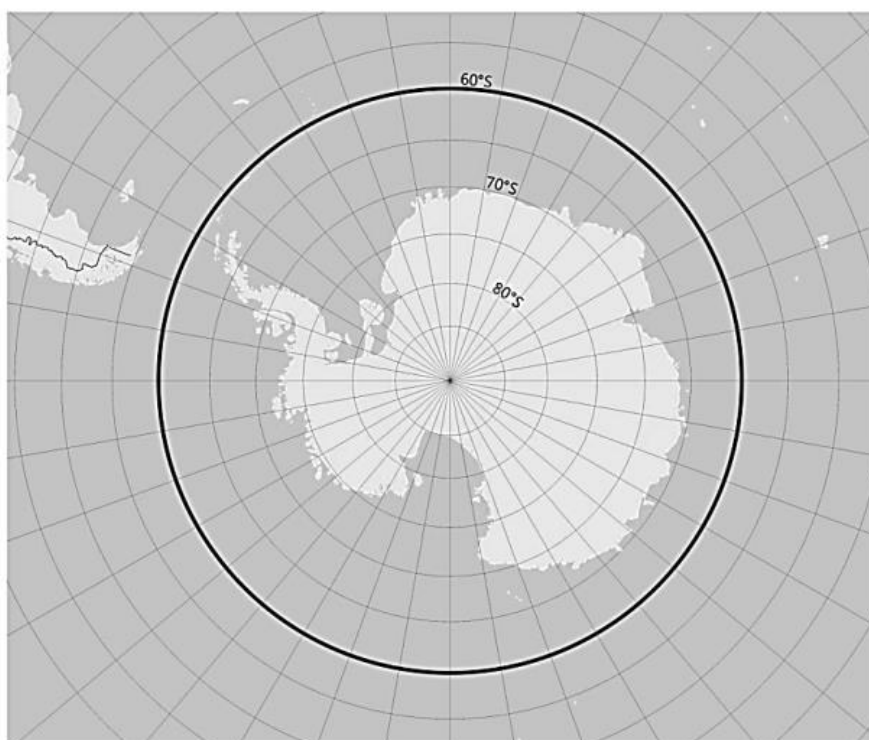

Fig. 11.2 Maximum extent of Arctic waters application



1.2.2 Ice Class Ships*

When the requirements in **Chapter 8** of this Part are applied, the definitions of terms and symbols which appear in this Part are to be as specified in the following **(1)** to **(4)**, unless specified elsewhere.

(1) Ice Class

Ice Class is classified into the following five classes. It is the responsibility of the Owner to determine which class is most suitable for his requirements.

- (a) *IA Super*
- (b) *IA*
- (c) *IB*
- (d) *IC*
- (e) *ID*

(2) Hull areas

The bow, midbody and stern regions in way of hull part are defined for *IA Super*, *IA*, *IB* and *IC* ice class ships and the bow region is defined for *ID* ice class ships as follows:

(a) Bow region

From the stem to a line parallel to and $0.04L$ aft of the forward border line of the part of the hull where the waterlines run parallel to the centerline. For *IA Super* and *IA* ice class ships the overlap over the border line need not exceed 6 metres, and for *IB*, *IC* and *ID* ice class ships this overlap need not exceed 5 metres.

(b) Midbody region

From the aft boundary of the bow region to a line parallel to and $0.04L$ aft of the aft borderline of the part of the hull where the waterlines run parallel to the centreline. For *IA Super* and *IA* ice class ships the overlap over the borderline need not exceed 6 metres, and for *IB* and *IC* ice class ships this overlap need not exceed 5 metres.

(c) Stern region

From the aft boundary of the midbody region to the stern

- #### (3) The engine output (H) is the total Maximum Continuous output of the engine. If the output of the propulsion machinery is restricted by technical means or by any regulations applicable to the ship, H is to be taken as the restricted output. If additional power sources are available for propulsion power (e.g. shaft motors), in addition to the power of the main engine(s), they are also to be included in the total engine output.

(4) Blade order

Product of number of rotations multiplied by number of blades

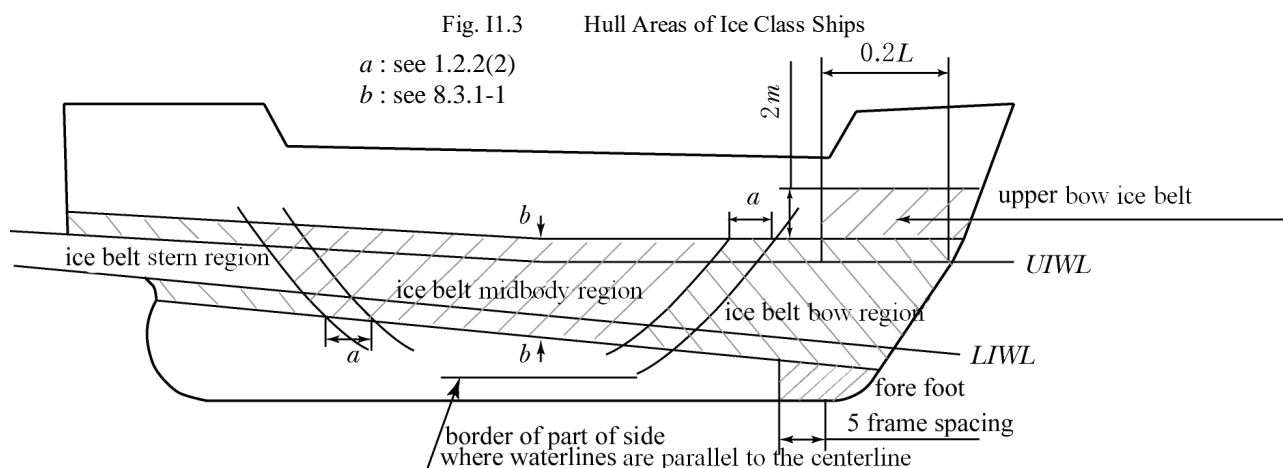

1.3 Performance Standards (*Polar Code*, Part I-A, 1.4)

1.3.1 General*

Unless expressly provided otherwise, ship systems and equipment addressed in [Chapter 2](#) to [Chapter 7](#) of this Part, [Rules for Safety Equipment](#) and [Rules for Radio Installations](#) are to satisfy at least the same performance standards referred to [Rules for the Survey and Construction of Steel Ships](#), [Rules for Safety Equipment](#) and [Rules for Radio Installations](#).

1.3.2 Ships Operating in Low Air Temperature

1 For ships operating in low air temperature, a polar service temperature (*PST*) is to be specified. *PST* is to be at least 10C below the lowest *MDLT* for the intended area and season of operation in polar waters. Systems and equipment required by [Chapter 2](#) to [Chapter 7](#) of this Part, [Rules for Safety Equipment](#) and [Rules for Radio Installations](#) are to be fully functional at the polar service temperature.

2 For ships operating in low air temperature, survival systems and equipment required by *Polar Code*, Part I-A, Chapter 8 are to be fully operational at the polar service temperature during the maximum expected rescue time.

1.4 Sources of Hazards (with reference to *Polar Code*, INTRODUCTION, 3)

1.4.1 Sources of Hazards

1 The provision of [Chapter 2](#) to [Chapter 7](#) of this Part, [Rules for Marine Pollution Prevention Systems](#), [Rules for Safety Equipment](#) and [Rules for Radio Installations](#) considers hazards specified in the following (1) to (10) which may lead to elevated levels of risk due to increased probability of occurrence, more severe consequences, or both:

- (1) Ice, as it may affect hull structure, stability characteristics, machinery systems, navigation, the outdoor working environment, maintenance and emergency preparedness tasks and malfunction of safety equipment and systems;
- (2) experiencing topside icing, with potential reduction of stability and equipment functionality;
- (3) low temperature, as it affects the working environment and human performance, maintenance and emergency preparedness tasks, material properties and equipment efficiency, survival time and performance of safety equipment and systems;
- (4) extended periods of darkness or daylight as it may affect navigation and human performance;
- (5) high latitude, as it affects navigation systems, communication systems and the quality of ice imagery information;
- (6) remoteness and possible lack of accurate and complete hydrographic data and information, reduced availability of navigational aids and seamarks with increased potential for groundings compounded by remoteness, limited readily deployable SAR facilities, delays in emergency response and limited communications capability, with the potential to affect incident response;
- (7) potential lack of ship crew experience in polar operations, with potential for human error;

- (8) potential lack of suitable emergency response equipment, with the potential for limiting the effectiveness of mitigation measures;
- (9) rapidly changing and severe weather conditions, with the potential for escalation of incidents; and
- (10) the environment with respect to sensitivity to harmful substances and other environmental impacts and its need for longer restoration.

2 The risk level within polar waters may differ depending on the geographical location, time of the year with respect to daylight, ice-coverage, etc. Thus, the mitigating measures required to address the hazards specified in **-1(1)** to **(10)** above may vary within polar waters and may be different in Arctic and Antarctic waters.

1.5 Operational Assessment (*Polar Code, Part I-A, 1.5*)

1.5.1 Operational Assessment*

In order to establish procedures or operational limitations, an assessment of the ship and its equipment is to be carried out, taking into consideration the following **(1)** to **(3)**. The Society may require submission of data regarding the assessment.

- (1) The anticipated range of operating and environmental conditions, such as following **(a)** to **(d)**.
 - (a) Operation in low air temperature
 - (b) Operation in ice
 - (c) Operation in high latitude
 - (d) Potential for abandonment onto ice or land
- (2) Hazards, as listed in **1.4.1**, as applicable
- (3) Additional hazards, if identified

Chapter 2 POLAR WATER OPERATIONAL MANUAL (PWOM)

2.1 Goal (*Polar Code, Part I-A, 2.1*)

The goal of this chapter is to provide the owner, operator, master and crew with sufficient information regarding the ship's operational capabilities and limitations in order to support their decision-making process.

2.2 Functional Requirements (*Polar Code, Part I-A, 2.2*)

2.2.1 Functional Requirements

In order to achieve the goal set out in 2.1 above, the following functional requirements are embodied in the regulations of this chapter.

- (1) The Manual is to include information on the ship-specific capabilities and limitations in relation to the assessment required under 1.5.
- (2) The Manual is to include or refer to specific procedures to be followed in normal operations and in order to avoid encountering conditions that exceed the ship's capabilities.
- (3) The Manual is to include or refer to specific procedures to be followed in the event of incidents in polar waters.
- (4) The Manual is to include or refer to specific procedures to be followed in the event that conditions are encountered which exceed the ship's specific capabilities and limitations in (1).
- (5) The Manual is to include or refer to procedures to be followed when using icebreaker assistance, as applicable.

2.3 Regulations (*Polar Code, Part I-A, 2.3*)

2.3.1 Polar Water Operational Manual*

In order to comply with the functional requirements of 2.2.1, the Manual is to be carried on board.

2.3.2 Operational Assessment

In order to comply with the functional requirements of 2.2.1(1), the Manual is to contain, where applicable, the methodology used to determine capabilities and limitations in ice.

2.3.3 Procedures for Normal Operations

In order to comply with the functional requirements of 2.2.1(2), the Manual is to include risk-based procedures for the following:

- (1) voyage planning to avoid ice and/or temperatures that exceed the ship's design capabilities or limitations;
- (2) arrangements for receiving forecasts of the environmental conditions;
- (3) means of addressing any limitations of the hydrographic, meteorological and navigational information available;
- (4) operation of equipment required under other chapters of this Code; and
- (5) implementation of special measures to maintain equipment and system functionality under low temperatures, topside icing and the presence of sea ice, as applicable.

2.3.4 Procedures for Incidents in Polar Waters*

In order to comply with the functional requirements of 2.2.1(3), the Manual is to include risk-based procedures to be followed for:

- (1) contacting emergency response providers for salvage, search and rescue (*SAR*), spill response, etc., as applicable; and
- (2) in the case of ships ice strengthened in accordance with Chapter 3, procedures for maintaining life support and ship integrity in the event of prolonged entrapment by ice.

2.3.5 Procedures for Conditions Exceeding Ship Design Capabilities and Limitations

In order to comply with the functional requirements of 2.2.1(4), the Manual is to include risk-based procedures to be followed for measures to be taken in the event of encountering ice and/or temperatures which exceed the ship's design capabilities or limitations.

2.3.6 Procedures for Icebreaker Assistance*

In order to comply with the functional requirements of [2.2.1\(5\)](#), the Manual is to include risk-based procedures for monitoring and maintaining safety during operations in ice, as applicable, including any requirements for escort operations or icebreaker assistance. Different operational limitations may apply depending on whether the ship is operating independently or with icebreaker escort. Where appropriate, the *PWOM* is to specify both options.

Chapter 3 SHIP STRUCTURE

3.1 Goal (*Polar Code, Part I-A, 3.1*)

The goal of this chapter is to provide that the material and scantlings of the structure retain their structural integrity based on global and local response due to environmental loads and conditions.

3.2 Functional Requirements (*Polar Code, Part I-A, 3.2*)

3.2.1 Functional Requirements

In order to achieve the goal set out in **3.1** above, the following functional requirements are embodied in the regulations of this chapter:

- (1) for ships intended to operate in low air temperature, materials used are to be suitable for operation at the ships polar service temperature; and
- (2) in ice strengthened ships, the structure of the ship is to be designed to resist both global and local structural loads anticipated under the foreseen ice conditions.

3.3 Regulations (*Polar Code, Part I-A, 3.3*)

3.3.1 Materials of Structures*

In order to comply with the functional requirements of **3.2.1(1)** above, materials of exposed structures in ships are to be approved by the Society taking into account **Annex 1 “Special Requirements for the Materials, Hull Structures, Equipment and Machinery of Polar Class Ships”**, **3.2.2.2, Part 1, Part C** or other standards offering an equivalent level of safety based on the polar service temperature.

3.3.2 Hull Structures*

In order to comply with the functional requirements of **3.2.1(2)** above, the following apply:

- (1) Scantlings of category *A* ships are to comply with the following **(a)** or **(b)**.
 - (a) The scantlings are to comply with the requirements regarding to hull structures for any polar class *PC1* to *PC5* and be approved by the Society.
 - (b) The scantlings are to comply with other standards offering an equivalent level of safety and be approved by the Society.
- (2) Scantlings of category *B* ships are to comply with the following **(a)** or **(b)**.
 - (a) The scantlings are to comply with the requirements regarding to hull structures for polar class *PC6* or *PC7* and be approved by the Society.
 - (b) The scantlings are to comply with other standards offering an equivalent level of safety and be approved by the Society.
- (3) Scantlings of ice strengthened category *C* ships are to be approved by the Society, taking into account acceptable standards adequate for the ice types and concentrations encountered in the area of operation; and
- (4) A category *C* ship need not be ice strengthened if, in the opinion of the Society, the ship’s structure is adequate for its intended operation.

Chapter 4 SUBDIVISION AND STABILITY

4.1 Goal (*Polar Code, Part I-A, 4.1*)

The goal of this chapter is to ensure adequate subdivision and stability in both intact and damaged conditions.

4.2 Functional Requirements (*Polar Code, Part I-A, 4.2*)

4.2.1 Functional Requirements

In order to achieve the goal set out in 4.1 above, the following functional requirements are embodied in the regulations of this chapter:

- (1) Ships are to have sufficient stability in intact conditions when subject to ice accretion; and
- (2) Ships of category *A* and *B*, constructed on or after 1 January 2017, are to have sufficient residual stability to sustain ice-related damages.

4.3 Regulations (*Polar Code, Part I-A, 4.3*)

4.3.1 Stability in Intact Conditions

In order to comply with the functional requirement of 4.2.1(1), the following apply.

- (1) For ships operating in areas and during periods where ice accretion is likely to occur, the following icing allowance is to be made in the stability calculations:
 - (a) 30 kg/m² on exposed weather decks and gangways;
 - (b) 7.5 kg/m² for the projected lateral area of each side of the ship above the water plane; and the projected lateral area of discontinuous surfaces of rail, sundry booms, spars (except masts) and rigging of ships having no sails and the projected lateral area of other small objects is to be computed by increasing the total projected area of continuous surfaces by 5% and the static moments of this area by 10%.
- (2) Ships operating in areas and during periods where ice accretion is likely to occur are to be:
 - (a) designed to minimize the accretion of ice; and
 - (b) equipped with such means for removing ice as the Society may require; for example, electrical and pneumatic devices, and/or special tools such as axes or wooden clubs for removing ice from bulwarks, rails and erections.
- (3) Information on the icing allowance included in the stability calculations is to be given in the *PWOM*.
- (4) Ice accretion is to be monitored and appropriate measures taken to ensure that the ice accretion does not exceed the values given in the *PWOM*.

4.3.2 Stability in Damaged Conditions

In order to comply with the functional requirements of 4.2.1(2), ships of categories *A* and *B*, constructed on or after 1 January 2017, are to be able to withstand flooding resulting from hull penetration due to ice impact, of which the damage extent is to be in accordance with the following (1) to (3). The residual stability following ice damage is to be such that the factor s_i , as defined in 2.3.2.3, Part 1, Part C or 4.2.3-1, Part CS, is equal to one for all loading conditions used to calculate the attained subdivision index *A* in 2.3.2.1, Part 1, Part C or 4.2.1-2, Part CS. However, for cargo ships that comply with subdivision and damage stability regulations, the residual stability criteria of that instrument is to be met for each loading condition.

- (1) the longitudinal extent is 0.045 times the upper ice waterline length if centred forward of the maximum breadth on the upper ice waterline, and 0.015 times the upper ice waterline length otherwise, and are to be assumed at any longitudinal position along the ship's length;
- (2) the transverse penetration extent is 760 mm, measured normal to the shell over the full extent of the damage; and
- (3) the vertical extent is the lesser of 0.2 times the upper ice waterline draught or the longitudinal extent, and is to be assumed at any vertical position between the keel and 1.2 times the upper ice waterline draught.

Chapter 5 WATERTIGHT AND WEATHERTIGHT INTEGRITY

5.1 Goal (*Polar Code, Part I-A, 5.1*)

The goal of this chapter is to provide measures to maintain watertight and weathertight integrity.

5.2 Functional Requirements (*Polar Code, Part I-A, 5.2*)

5.2.1 Functional Requirements

In order to achieve the goal set out in [5.1](#) above, all closing appliances and doors relevant to watertight and weathertight integrity of the ship is to be operable.

5.3 Regulations (*Polar Code, Part I-A, 5.3*)

5.3.1 General

In order to comply with the functional requirements of [5.2.1](#) above, the following apply:

- (1) for ships operating in areas and during periods where ice accretion is likely to occur, means are to be provided to remove or prevent ice and snow accretion around hatches and doors; and
- (2) in addition to (1) above, for ships intended to operate in low air temperature the following apply:
 - (a) if the hatches or doors are hydraulically operated, means are to be provided to prevent freezing or excessive viscosity of liquids; and
 - (b) watertight and weathertight doors, hatches and closing devices which are not within an habitable environment and require access while at sea are to be designed to be operated by personnel wearing heavy winter clothing including thick mittens.

Chapter 6 MACHINERY INSTALLATIONS

6.1 Goal (*Polar Code, Part I-A, 6.1*)

The goal of this chapter is to ensure that, machinery installations are capable of delivering the required functionality necessary for safe operation of ships.

6.2 Functional Requirements (*Polar Code, Part I-A, 6.2*)

6.2.1 Functional Requirements

In order to achieve the goal set out in 6.1, the following (1) to (3) are to be complied with.

- (1) Machinery installations are to provide functionality under the anticipated environmental conditions, taking into account the following (a) to (e):
 - (a) Ice accretion and/or snow accumulation;
 - (b) Ice ingestion from seawater;
 - (c) Freezing and increased viscosity of liquids;
 - (d) Seawater intake temperature; and
 - (e) Snow ingestion.
- (2) In addition to (1) above, for ships intended to operate in low air temperatures the following (a) and (b) are to be complied with.
 - (a) Machinery installations are to provide functionality under the anticipated environmental conditions, also taking into account the following i) and ii):
 - i) cold and dense inlet air; and
 - ii) loss of performance of battery or other stored energy device.
 - (b) Materials used are to be suitable for operation at the ships polar service temperature.
- (3) In addition to (1) and (2) above, for ships ice strengthened in accordance with Chapter 3 of this Part, machinery installations are to provide functionality under the anticipated environmental conditions, taking into account loads imposed directly by ice interaction.

6.3 Regulations (*Polar Code, Part I-A, 6.3*)

6.3.1 General*

In order to comply with the functional requirement of 6.2.1(1), taking into account the anticipated environmental conditions, the following (1) to (3) are to apply.

- (1) Machinery installations and associated equipment are to be protected against the effect of ice accretion and/or snow accumulation, ice ingestion from sea water, freezing and increased viscosity of liquids, seawater intake temperature and snow ingestion.
- (2) Working liquids are to be maintained in a viscosity range that ensures operation of the machinery.
- (3) Seawater supplies for machinery systems are to be designed to prevent ingestion of ice or otherwise arranged to ensure functionality.

6.3.2 Ships intended to Operate in Low Air Temperatures*

In addition to 6.3.1, for ships intended to operate in low air temperatures, the following (1) to (3) are to apply:

- (1) In order to comply with 6.2.1(2), exposed machinery and electrical installation and appliances are to function at the polar service temperature;
- (2) In order to comply with 6.2.1(2)(a), means are to be provided to ensure that combustion air for internal combustion engines

driving essential machinery is maintained at a temperature in compliance with the criteria provided by the engine manufacturer; and

- (3) In order to comply with **6.2.1(2)(b)**, materials of exposed machinery and foundations are to be either of the following **(a)** or **(b)**:
- (a) Those complying the requirements specified in **Annex 1 “Special Requirements for the Materials, Hull Structures, Equipment and Machinery of Polar Class Ships”** applicable to materials of machinery installations and approved by the Society; or
 - (b) Those complying with other standards offering an equivalent level of safety based on the polar service temperature and approved by the Administration.

6.3.3 Ice Strengthened Ships*

In addition to **6.3.1** and **6.3.2**, for ships ice strengthened in accordance with **Chapter 3** of this Part, in order to comply with **6.2.1(3)**, the following **(1)** to **(3)** are to apply.

- (1) Scantlings of propeller blades, propulsion line, steering equipment and other appendages of category *A* ships are to be either of the following **(a)** or **(b)**:
 - (a) Those complying with the requirements specified in **Annex 1 “Special Requirements for the Materials, Hull Structures, Equipment and Machinery of Polar Class Ships”** applicable to scantlings of propeller blades, propulsion line, steering equipment and other appendages and approved by the Society; or
 - (b) Those complying with other standards offering an equivalent level of safety and approved by the Administration.
- (2) Scantlings of propeller blades, propulsion line, steering equipment and other appendages of category *B* ships are to be either of the following **(a)** or **(b)**:
 - (a) Those complying with the requirements specified in **Annex 1 “Special Requirements for the Materials, Hull Structures, Equipment and Machinery of Polar Class Ships”** applicable to scantlings of propeller blades, propulsion line, steering equipment and other appendages and approved by the Society; or
 - (b) Those complying with other standards offering an equivalent level of safety and approved by the Administration.
- (3) Scantlings of propeller blades, propulsion line, steering equipment and other appendages of ice-strengthened category *C* ships are to be approved by the Administration or Society taking into account acceptable standards adequate with the ice types and concentration encountered in the area of operation.

Chapter 7 FIRE SAFETY/PROTECTION

7.1 Goal (*Polar Code, Part I-A, 7.1*)

The goal of this chapter is to ensure that fire safety systems and appliances are effective and operable, and that means of escape remain available so that persons on board can safely and swiftly escape to the lifeboat and liferaft embarkation deck under the expected environmental conditions.

7.2 Functional Requirements (*Polar Code, Part I-A, 7.2*)

7.2.1 Functional Requirements

In order to achieve the goal set out in 7.1, the following (1) to (5) are to be complied with:

- (1) All components of fire safety systems and appliances if installed in exposed positions are to be protected from ice accretion and snow accumulation;
- (2) Local equipment and machinery controls are to be arranged so as to avoid freezing, snow accumulation and ice accretion and their location to remain accessible at all time;
- (3) The design of fire safety systems and appliances are to take into consideration the need for persons to wear bulky and cumbersome cold weather gear, where appropriate;
- (4) Means are to be provided to remove or prevent ice and snow accretion from accesses; and
- (5) Extinguishing media are to be suitable for intended operation.

7.2.2 Ships intended to Operate in Low Air Temperature

In addition to 7.2.1, for ships intended to operate in low air temperature, the following (1) and (2) are to be complied with:

- (1) All components of fire safety systems and appliances are to be designed to ensure availability and effectiveness under the polar service temperature; and
- (2) Materials used in exposed fire safety systems are to be suitable for operation at the polar service temperature.

7.3 Regulations (*Polar Code, Part I-A, 7.3*)

7.3.1 Fire Safety Systems and Appliances Installed in Exposed Positions

In order to comply with the requirement of 7.2.1(1), the following (1) and (2) are to apply:

- (1) Isolating and pressure/vacuum valves in exposed locations are to be protected from ice accretion and remain accessible at all time; and
- (2) All two-way portable radio communication equipment is to be operable at the polar service temperature.

7.3.2 Local Equipment and Machinery Controls

In order to comply with the requirement of 7.2.1(2), the following (1) to (4) are to apply:

- (1) Fire pumps including emergency fire pumps, water mist and water spray pumps are to be located in compartments maintained above freezing;
- (2) The fire main is to be arranged so that exposed sections can be isolated and means of draining of exposed sections are to be provided. Fire hoses and nozzles need not be connected to the fire main at all times, and may be stored in protected locations near the hydrants;
- (3) Firefighter's outfits are to be stored in warm locations on the ship; and
- (4) Where fixed water-based firefighting systems are located in a space separate from the main fire pumps and use their own independent sea suction, this sea suction is to be also capable of being cleared of ice accumulation.

7.3.3 Ships Intended to Operate in Low Air Temperatures*

In addition to 7.3.1 and 7.3.2, for ships intended to operate in low air temperature, the following (1) and (2) are to apply:

- (1) In order to comply with the requirement of 7.2.2(1), portable and semi-portable extinguishers are to be located in positions

protected from freezing temperatures, as far as practical. Locations subject to freezing are to be provided with extinguishers capable of operation under the polar service temperature.

- (2) In order to comply with the functional requirements of [7.2.2\(2\)](#), materials of exposed fire safety systems are to be acceptable to the Society.

Chapter 8 ICE CLASS SHIPS

8.1 General

8.1.1 Application*

- 1 The requirements in this Chapter apply to hull structure, equipment and machinery, etc. of ice class ships.
- 2 The requirements in this Chapter are framed for the ice strengthening of ships which are intended to navigate in the Northern Baltic complying with the *Finnish-Swedish Ice Class Rules* or in the Canadian Arctic complying with the *Arctic Shipping Safety and Pollution Prevention Regulations*.

8.1.2 Maximum and Minimum Draught

- 1 The maximum and minimum ice draughts at fore and aft perpendicular are to be determined in accordance with the upper and lower ice waterlines.
- 2 Restrictions on draughts when operating in ice are to be documented and kept on board readily available to the master.
- 3 If the summer load line in fresh water is anywhere located at a higher level than the *UIWL*, the ship's side is to be provided with a warning triangle and with an ice class draught mark at the maximum permissible ice class draught amidships. (see [Fig. 18.1](#))
- 4 Any ballast tank, situated above the *LIWL* and needed to load down the ship to this water line is to be equipped with proper devices to prevent the water from freezing.
- 5 The propeller is to be fully submerged, if possible entirely below the ice.
- 6 The minimum forward draught is not to be less than that obtained from the following formula.

$$(2.0 + 0.00025\Delta)h_0(m) \quad \text{but need not exceed } 4h_0$$

where

Δ : The displacement of the ship (t) determined from the waterline on the *UIWL*. Where multiple waterlines are used for determining the *UIWL*, the displacement is to be determined from the waterline corresponding to the greatest displacement.

h_0 : Constant given in [Table 18.1](#) according to the respective ice class

Table 18.1 Value of Constant h_0

Ice Class	h_0
<i>IA Super</i>	1.0
<i>IA</i>	0.8
<i>IB</i>	0.6
<i>IC</i>	0.4
<i>ID</i>	0.4

Fig. I8.1 Ice Class Draught Marking

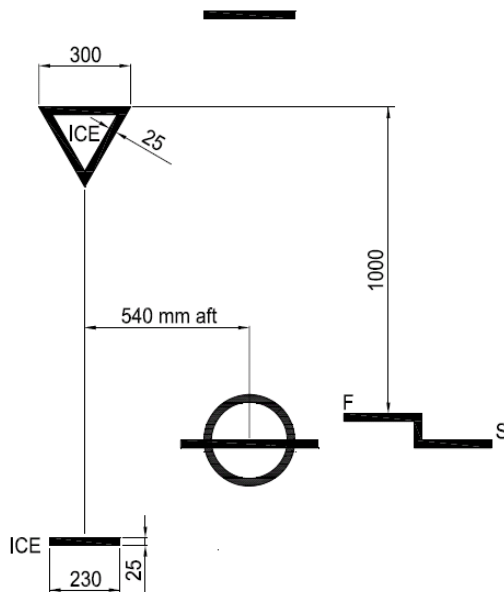

Notes:

1. The upper edge of the warning triangle is to be located vertically above the Ice mark, 1,000mm higher than the Summer Load Line in fresh water but in no case higher than the deck line. The sides of the triangle are to be 300mm in length.
2. The ice class draught mark is to be located 540mm abaft the centre of the load line ring or 540mm abaft the vertical line of the timber load line mark, if applicable.
3. The marks and figures are to be cut out of 5mm - 8mm plate and then welded to the ship's side. The marks and figures are to be painted in a red or yellow reflecting colour in order to make the marks and figures plainly visible even in ice conditions.
4. The dimensions of all figures are to be the same as those used in the load line mark.

8.2 Design Ice Pressures

8.2.1 Design Ice Pressures

1 Design ice pressure (P) is not to be less than that obtained from the following formula:

$$C_d C_p C_a p_0 \text{ (MPa)}$$

where

C_d : As given by the following formula. However, C_d needs not to exceed 1.0.

$$C_d = \frac{ak + b}{1000}$$

$$k = \frac{\sqrt{\Delta H}}{1000}$$

Δ : Displacement (t) of the ship on the maximum draught specified in 8.1.2-6

H : Engine output (kW)

a and b : As given in Table 18.2 according to the region under consideration and the value of k .

C_p : As given in Table 18.3 according to the ice class and the region under consideration.

p_0 : The nominal ice pressure; the value 5.6 MPa is to be used.

C_a : As given by the following formula. However, C_a is not to be less than 0.35 but need not to exceed 1.0.

$$\sqrt{\frac{0.6}{l_a}}$$

l_a : To be taken as specified in Table 18.4 according to the structural member under consideration.

Table I8.2 Value of a and b

	Bow region		Midbody & Stern regions	
	$k \leq 12$	$k > 12$	$k \leq 12$	$k > 12$
a	30	6	8	2
b	230	518	214	286

 Table I8.3 Coefficient C_p

Ice Class	Bow region	Midbody region	Stern region
<i>IA Super</i>	1.00	1.00	0.75
<i>IA</i>	1.00	0.85	0.65
<i>IB</i>	1.00	0.70	0.45
<i>IC</i>	1.00	0.50	0.25
<i>ID</i>	1.00	-	-

 Table I8.4 Value of l_a

Structural member	Type of framing	l_a (m)
Shell	Transverse	Frame spacing
	Longitudinal	1.7-spacing of frame
Frames	Transverse	Frame spacing
	Longitudinal	Span of frame
Ice stringer	-	Span of stringer
Web frame	-	2-spacing of web frame

Note:

The frame spacing and spans are normally assumed to be measured along the plate and perpendicular to the axis of the stiffener for plates, along the flange for members with a flange, and along the free edge for flat bar stiffeners. For curved members, the span or spacing is defined as the chord length between the span or spacing points. The span points are defined by the intersection between the flange or upper edge of the member and the supporting structural element. (See Fig. I8.2)

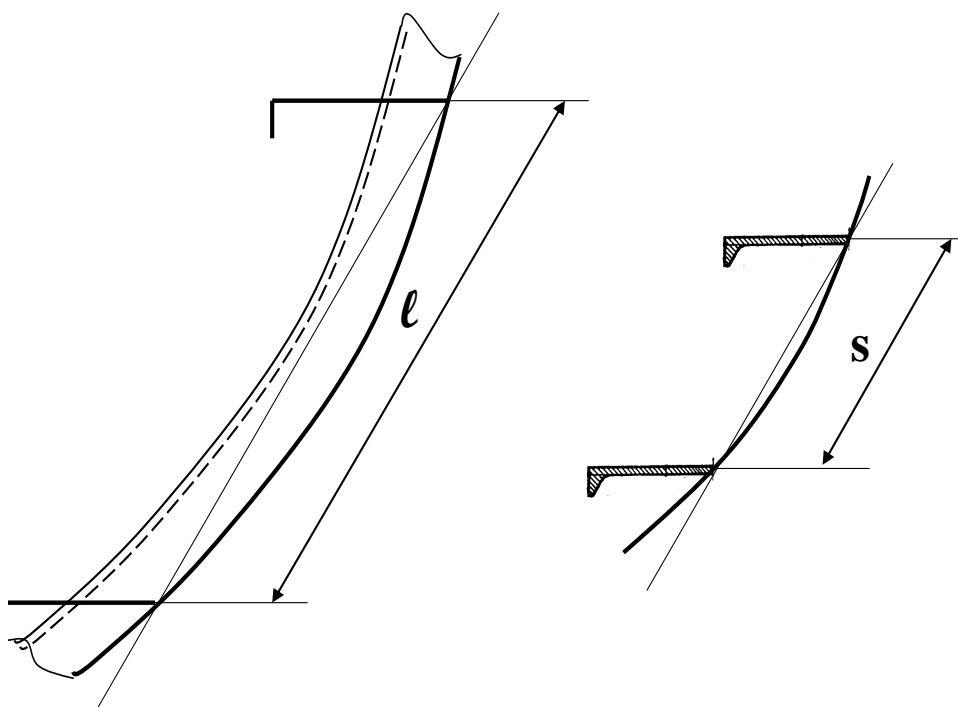
 Fig. I8.2 Definition of the Frame Span l and Frame Spacing s for Curved Members

- 2 h is the height of the area under the ice pressure (P) specified in -1. and is to be as given in [Table 18.5](#) according to the ice class.

Table I8.5 Value of h

Ice Class	h (m)
<i>IA Super</i>	0.35
<i>IA</i>	0.30
<i>IB</i>	0.25
<i>IC</i>	0.22
<i>ID</i>	0.22

8.3 Hull Structures and Equipment

8.3.1 Shell Plating

1 The vertical extension of the ice belt is to be as given in [Table I8.6](#) according to the ice class and is to comply with the following requirements.

(1) Fore foot

For *IA Super* ice class ships with the shell plating below the ice belt from the stem to a position five main frame spaces abaft the point where the bow profile departs from the keel line is to be ice-strengthened in the same way as the bow region.

(2) Upper bow ice belt

For *IA Super* and *IA* ice class ships with an open water service speed equal to or exceeding 18 *knots*, the shell plate from the upper limit of the ice belt to 2m above it and from the stem to a position at least 0.2L abaft the forward perpendicular, is to be ice-strengthened in the same way as the midbody region. A similar strengthening of the bow region is to apply to a ship with lower service speed, when it is, e.g. on the basis of the model tests, evident that the ship will have a high bow wave.

(3) Side scuttles are not to be situated in the ice belt.

(4) If the weather deck in any part of the ship is situated below the upper limit of the ice belt, the bulwark and the construction of the freeing ports are to be given at least the same strength as is required for the shell in the ice belt.

Table I8.6 Vertical Extension of the Ice Belt

Ice Class	Hull region	Above the <i>UIWL</i>	Below the <i>LIWL</i>
<i>IA Super</i>	Bow	0.6m	1.20m
	Midbody		
	Stern		1.0m
<i>IA</i>	Bow	0.5m	0.90m
	Midbody		0.75m
	Stern		
<i>IB</i>	Bow	0.4m	0.70m
	Midbody		0.60m
Stern			
<i>ID</i>	Bow	0.4m	0.70m

2 The thickness of shell plating in the ice belt is not to be less than that obtained from the following formula according to the type of framing.

$$\text{For the transverse framing: } 667s \sqrt{\frac{f_1 p P L}{\sigma_y}} + t_c \text{ (mm)}$$

$$\text{For the longitudinal framing: } 667s \sqrt{\frac{p}{f_2 \sigma_y}} + t_c \text{ (mm)}$$

where

s : Frame spacing (m)

- p_{PL} : 0.75*p* (MPa)
 p : As specified in **8.2.1-1**
 f_1 : As given in the following formula. Where, however, f_1 is greater than 1.0, f_1 is to be taken as 1.0.

$$1.3 - \frac{4.2}{(h/s + 1.8)^2}$$
 f_2 : As given in the following formula depending on the value of h/s
 where $h/s < 1.0$: $0.6 + \frac{0.4}{h/s}$
 where $1.0 \leq h/s < 1.8$: $1.4 - 0.4(h/s)$
 h : As specified in **8.2.1-2**
 σ_y : Yield stress of the materials (N/mm^2),
 for which the following values are to be used
 235 N/mm^2 for normal-strength hull structural steel
 315 N/mm^2 for high-strength hull structural steel
 However, if steels with different yield stresses than those given above are used, the value is to be at the discretion of the Society.
 t_c : 2mm: If special surface coating, by experience shown capable to withstand the abrasion by ice, is applied and maintained, lower values may be approved.

8.3.2 General Requirements for Frames*

1 The vertical extension of the ice strengthening of the framing is to be at least as given in **Table 18.7** according to the respective ice classes and regions. Where an upper bow ice belt is required in **8.3.1-1**, the ice strengthening part of the framing is to be extended at least to the top of this ice belt. Where the ice strengthening would go beyond a deck, the top or bottom plating of a tank or tank top by no more than 250mm, it can be terminated at that deck, top or bottom plating of the tank or tank top.

2 Within the ice strengthening area all frames are to be effectively attached to all the supporting structures. A longitudinal frame is to be attached to all the supporting web frames and bulkheads by brackets at both ends. When a transverse frame terminates at a stringer or deck, a bracket or similar construction is to be fitted. When a frame is running through the supporting structure, both sides of the web plate of the frame are to be connected to the structure by direct welding, collar plate or lug. When a bracket is installed, it is to have at least the same thickness as the web plate of the frame and the edge is to be appropriately stiffened against buckling.

3 The following are to apply to support of frames against instability, in particular tripping:

- (1) The frames are to be attached to the shell by double continuous welds. No scalloping is allowed except when crossing shell plate butts.
- (2) The web thickness of the frames is not to be less than the greatest of the following (a) to (c).

(a)
$$\frac{h_w \sqrt{\sigma_y}}{C}$$

h_w : web height (mm)

C : 805 for profiles

282 for flat bars

σ_y : As specified in **8.3.1-2**

- (b) Half of the net thickness of the shell plating $t - t_c$. For the purpose of calculating the minimum web thickness of frames, the required thickness of the shell plating is to be calculated according to **8.3.1-2** using the yield strength σ_y of the frames
- (c) 9 mm
- (3) Where there is a deck, top or bottom plating of a tank, tank top or bulkhead in lieu of a frame, the plate thickness of this is to be as per the preceding (2), to a depth corresponding to the height of adjacent frames. In such a case, the material properties of the deck, top or bottom plating of the tank, tank top or bulkhead and the frame height h_w of the adjacent frames are to be used in the calculations, and the constant C is to be 805.
- (4) Asymmetrical frames and frames which are not at right angles to the shell (web less than 90 degrees to the shell) are to be supported against tripping by brackets, intercoastals, stringers or similar, at a distance not exceeding 1,300 mm. For frames with spans greater than 4 m, the extent of antitripping supports is to be applied to all regions and for all ice classes. For frames with spans less than or equal to 4 m, the extent of antitripping supports is to be applied to all regions for ice class *IA Super*, to the

bow and midbody regions for ice class *IA*, and to the bow region for ice classes *IB* and *IC*. Direct calculation methods may be applied to demonstrate the equivalent level of support provided by alternative arrangements.

Table 18.7 Vertical Extension of the Ice Strengthening of Framing

Ice Class	Hull region	Above the <i>UIWL</i>	Below the <i>LIWL</i>
<i>IA Super</i>	Bow	1.2 m	Down to tank top or below top of the floors
	Midbody		2.0m
	Stern		1.6m
<i>IA</i> <i>IB</i> <i>IC</i>	Bow	1.0 m	1.6m
	Midbody		1.3m
	Stern		1.0m
<i>ID</i>	Bow	1.0 m	1.6m

8.3.3 Transverse Frames

1 The section modulus and the effective shear area of a main or intermediate transverse frame specified in 8.3.2-1 are to be not less than that obtained from the following formula:

$$\text{Section modulus: } \frac{pshl}{m_t \sigma_y} \times 10^6 \text{ (cm}^3\text{)}$$

$$\text{Effective shear area: } \frac{\sqrt{3} f_3 phs}{2 \sigma_y} \times 10^4 \text{ (cm}^2\text{)}$$

where

p : As specified in 8.2.1-1

s : Frame spacing (m) (See the note to Table 18.4)

h : As specified in 8.2.1-2

l : Span of the frame (m) (See the note to Table 18.4)

m_t : As given by the following formula



$$\frac{7m_0}{7 - 5h/l}$$

m_0 : As specified in Table 18.8

f_3 : Factor which takes into account the maximum shear force versus the load location and the shear stress distribution, taken as 1.2

σ_y : As specified in 8.3.1-2.

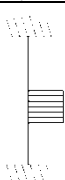
Table I8.8 Value of m_0

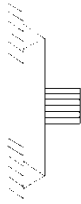
Boundary condition	m_0	Example
	7.0	Frames in a bulk carrier with top side tanks
	6.0	Frames extending from the tank top to the upper deck of a single decked ship
	5.7	Continuous frames between several decks or stringers
	5.0	Frames extending between two decks only

Note:

The boundary conditions are those for the main and intermediate frames. Load is applied at mid span.

2 Notwithstanding the -1 above, where less than 15% of the span, l , of the frame is situated within the ice strengthening zone for frames, ordinary frame scantlings may be used.

3 The upper end of the strengthening part of a main frame and of an intermediate frame are to be attached to a deck, top or bottom plating of a tank or an ice stringer as specified in 8.3.5. Where a frame terminates above a deck or a stringer (hereinafter, referred to as the lower deck in this section) which is situated at or above the upper limit of the ice belt, the part of the frame above the lower deck is to be in accordance with the followings:

- (1) the part of the main frame and the intermediate frame may have the scantlings required by the ordinary frame; and
- (2) the upper end of the main frame and the intermediate frame is to be connected to a deck which situated above the lower deck (hereinafter, referred to as the higher deck in this section). However, the upper end of the intermediate frame may be connected to the adjacent main frames by a horizontal stiffener having the same scantlings as the main frame.

4 The lower end of the strengthened part of a main frame and of an intermediate ice frame is to be attached to a deck, top or bottom plating of a tank, tank top or ice stringer specified in 8.3.5. Where an intermediate frame terminates below a deck, top or bottom plating of a tank, tank top or ice stringer which is situated at or below the lower limit of the ice belt, the lower end may be connected to the adjacent main frames by a horizontal member of the same scantlings as the frames.

8.3.4 Longitudinal Frames*

1 The section modulus and effective shear area of a longitudinal frame in the extension specified in 8.3.2-1 are not to be less than those obtained by the following formulae. However, in calculating the actual shear area of the frames, the area of the brackets is not to be taken into account:

$$\text{Section modulus : } \frac{f_4 p h l^2}{m \sigma_y} \times 10^6 \text{ (cm}^3\text{)}$$

$$\text{Effective shear area : } \frac{\sqrt{3} f_4 f_5 p h l}{2 \sigma_y} \times 10^4 \text{ (cm}^2\text{)}$$

- f_4 : Factor which takes account of the load distribution to adjacent frames as given by the following formula.
 $(1 - 0.2h/s)$
- f_5 : Factor which takes into account the pressure definition and maximum shear force versus load location and also the shear stress distribution, taken as 2.16
- h : As specified in **8.2.1-2**
- s : Frame spacing (m) (See the note to **Table I8.4**)
- p : As specified in **8.2.1-1**
- l : Span of the longitudinal frame (m) (See the note to **Table I8.4**)
- m : Boundary condition factor is to be taken as 13.3 for a continuous beam with brackets. Where the boundary conditions deviate significantly from those of a continuous beam with brackets, a smaller boundary factor is to be adapted.
- σ_y : As specified in **8.3.1-2**

8.3.5 Ice Stringers*

1 The section modulus and effective shear area of a stringer situated within the ice belt are not to be less than those obtained by the following formulae:

$$\text{Section modulus : } \frac{f_6 f_7 p h l^2}{m \sigma_y} \times 10^6 \text{ (cm}^3\text{)}$$

$$\text{Effective shear area : } \frac{\sqrt{3} f_6 f_7 f_8 p h l}{2 \sigma_y} \times 10^4 \text{ (cm}^2\text{)}$$

- f_6 : Factor which takes account of the distribution of load to the transverse frames is to be taken as 0.9.
- f_7 : Safety factor of stringers is to be taken as 1.8.
- f_8 : Factor which takes into account the maximum shear force versus load location and the shear stress distribution, taken as 1.2.
- p : As specified in **8.2.1-1**
- h : As specified in **8.2.1-2**
- However, the product of p and h is not to be taken as less than 0.15
- l : Span of the stringer (m)
- m : Boundary condition factor as defined in **8.3.4-1**
- σ_y : As specified in **8.3.1-2**

2 The section modulus and effective shear area of a stringer situated outside the ice belt but supporting ice strengthened frames are not to be less than those obtained by the following formulae:

$$\text{Section modulus : } \frac{f_9 f_{10} p h l^2}{m \sigma_y} (1 - h_s/l_s) \times 10^6 \text{ (cm}^3\text{)}$$

$$\text{Effective shear area : } \frac{\sqrt{3} f_9 f_{10} f_{11} p h l}{2 \sigma_y} (1 - h_s/l_s) \times 10^4 \text{ (cm}^2\text{)}$$

- f_9 : Factor which takes account of load to the transverse frames is to be taken as 0.8.
- f_{10} : Safety factor of stringers is to be taken as 1.8.
- f_{11} : Factor which takes into account the maximum shear force versus load location and the shear stress distribution, taken as 1.2.
- p : As specified in **8.2.1-1**
- h : As specified in **8.2.1-2**
- However, the product of p and h is not to be taken as less than 0.15
- l : Span (m) of the stringer
- h_s : The distance to the ice belt
- l_s : The distance (m) to the adjacent ice stringer (m)
- m : Boundary condition factor as defined in **8.3.4-1**
- σ_y : As specified in **8.3.1-2**

3 Narrow deck strips abreast of hatches and serving as ice stringers are to comply with the section modulus and shear area

requirements in the preceding -1 and -2 respectively. In the case of very long hatches, the product p and h may be taken as less than 0.15 but in no case less than 0.10. Regard is to be paid to the deflection of the ship's sides due to ice pressure with respect to very long hatch openings, when designing weather deck, hatch covers and their fittings.

8.3.6 Web Frames

1 The load F transferred to a web frame from an ice stringer or from longitudinal framing is not to be less than that obtained by the following formula:

$$f_{12}phS \text{ (MN)}$$

f_{12} : Safety factor of web frames is to be taken as 1.8.

p : Ice pressure (MPa) as specified in 8.2.1-1, in calculating C_a however, l_a is to be taken as $2S$.

h : As specified in 8.2.1-2

However, the product of p and h is not to be taken as less than 0.15

S : Distance (m) between web frames

2 Notwithstanding the provisions specified in -1 above, in case the supported stringer is outside the ice belt, the force F may be reduced to that obtained by the following formula:

$$f_{12}phS(1 - h_s/l_s) \text{ (MN)}$$

h_s and l_s : As specified in 8.3.5-2

3 The section modulus and effective shear area are to be calculated by the following formulae:

$$\text{Effective shear area} : \frac{\sqrt{3}\alpha f_{13} Q}{\sigma_y} \times 10^4 \text{ (cm}^2\text{)}$$

$$\text{Section modulus} : \frac{M}{\sigma_y} \sqrt{\frac{1}{1 - (\gamma A/A_a)^2}} \times 10^6 \text{ (cm}^3\text{)}$$

f_{13} : Factor which takes into account the shear force distribution is to be taken as 1.1.

Q : Maximum calculated shear force under the load F transferred to a web frame from an ice stringer or from longitudinal framing as specified in -1 or -2, as given in the following formula:

$$Q = F$$

M : Maximum calculated bending moment under the load F transferred to a web frame from an ice stringer or from longitudinal framing as specified in -1 or -2, as given in the following formula:

$$M = 0.193Fl$$

l : Span (m) of the web frame

α and γ : As given in Table 18.9. For intermediate values of A_f/A_w is to be obtained by linear interpolation.

A : Required shear area (cm²)

A_a : Actual cross sectional area (cm²) of the web frame, as given in the following formula:

$$A_a = A_f + A_w$$

A_f : Actual cross sectional area (cm²) of free flange

A_w : Actual effective cross sectional area (cm²) of web plate

σ_y : As specified in 8.3.1-2

Table 18.9 Value of α and γ

A_f/A_w	0.00	0.20	0.40	0.60	0.80	1.00	1.20	1.40	1.60	1.80	2.00
α	1.50	1.23	1.16	1.11	1.09	1.07	1.06	1.05	1.05	1.04	1.04
γ	0.00	0.44	0.62	0.71	0.76	0.80	0.83	0.85	0.87	0.88	0.89

4 The scantlings of web frames may be calculated by direct analysis where deemed appropriate by the Society. In this case, the following are to be complied with:

- (1) The pressure to be used is $1.8p$ (MPa) where p is determined according to 8.2.1-1, and the load patch is to be applied at locations where the capacity of the structure under the combined effects of bending and shear are minimized.
- (2) The structure is to be checked with load centred at the $UIWL$, $0.5 h_0$ (m) below the $LIWL$, and positioned several vertical

locations in between. Several horizontal locations which are the locations centred at the mid-span or spacing are to be checked. If the load length l_a cannot be determined directly from the arrangement of the structure, several values of l_a may be checked using corresponding values for C_a .

- (3) Acceptance criterion for designs is that the combined stresses from bending and shear, using the von Mises yield criterion, is to be lower than the σ_y as specified in 8.3.1-2. When the direct analysis is using beam theory, the allowable shear stress is not to be greater than $0.9\tau_y$, where $\tau_y = \sigma_y/\sqrt{3}$

8.3.7 Stem

- 1 A stem is recommended to be similar to the structure shown in Fig. I8.3.
- 2 The plate thickness of a shaped plate stem and in the case of a blunt bow, any part of the shell where angle α and ψ as specified in 8.4.2-1 are respectively not less than 30 degrees and 75 degrees, is to be obtained from the formula in 8.3.1-2

where

s : Spacing (m) of elements supporting the plate

p_{PL} : Ice pressure (MPa) as specified in 8.2.1-1

l_a : Spacing (m) of vertical supporting elements

- 3 The stem and the part of a blunt bow specified in the preceding -2 is to be supported by floors or brackets spaced not more than 0.6m apart and having a thickness of at least half the plate thickness.
- 4 The reinforcement of the stem is to be extended from the keel to a point 0.75m above ULWL or, in case an upper bow ice belt is required in 8.3.1-1 to the upper limit of this.

Fig. I8.3 Examples of Suitable Stems

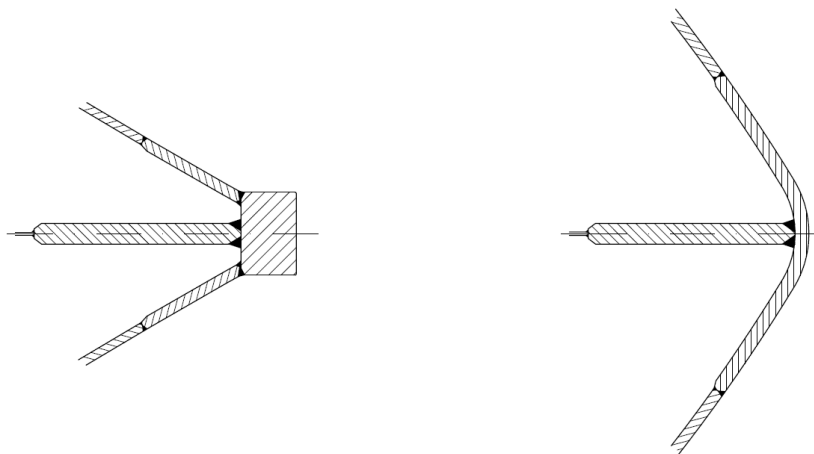

8.3.8 Arrangements for Towing*

Special consideration is to be given to the strength and installation of towing arrangements.

8.3.9 Stern*

- 1 The clearance between the propeller blade tip and hull, including the stern frame, is not to be less than h_0 as specified in 8.1.2-6 to prevent from occurring high loads on the blade tip.
- 2 On twin and triple screw ships, the ice strengthening of the shell and framing are to be extended to the tank top for 1.5 metres forward and aft of the side propellers.
- 3 On twin and triple screw ships, the shafting and stern tubes of side propellers are to be normally enclosed within plated bossings. If detached struts are used, their design, strength and attachment to the hull is to be duly considered.
- 4 The introduction of new propulsion arrangements with azimuthing thrusters, which provide an improved maneuverability, will result in increased ice loading of the stern region and the stern area. This fact is to be considered in the design of the aft/stern structure.

8.3.10 Bilge Keel*

Special consideration is to be given to the design of bilge keels.

8.4 Fundamental Requirements of Machinery

8.4.1 Materials

1 Materials for Machinery Parts exposed to Seawater

Materials exposed to seawater, such as propeller blades, propeller hub and blade bolts are to have an elongation of not less than 15% for the *U14A* test specimens given in **Part K**. Materials other than bronze and austenitic steel are to have an average impact energy value of 20 *J* at -10°C for the *U4* test specimens given in **Part K**. For nodular cast iron, average impact energy of 10 *J* at -10°C is required accordingly.

2 Materials for Machinery Parts exposed to Seawater Temperatures

Materials exposed to seawater temperatures are to be of steel or other ductile material approved by the Society. The materials are to have an average impact energy value of 20 *J* at -10°C for the *U4* test specimens given in **Part K**. The nodular cast iron of a ferrite structure type may be used for relevant parts other than bolts. The average impact energy for nodular cast iron is to be a minimum of 10 *J* at -10°C.

8.4.2 Engine Output

1 The engine output (*H*) is not to be less than the greater of two outputs determined by the following formula for the maximum draught amidships referred to as the *UIWL* and the minimum draught referred to as the *LIWL*, and in no case less than 1,000*kW* for ice class ships with *IA*, *IB*, *IC* and *ID*, and not less than 2,800*kW* for ice class ships with *IA Super*.

$$H = K_e \frac{(R_{CH}/1000)^{3/2}}{D_p}$$

H : Engine output (*kW*)

K_e : Constant given in **Table 18.10**

Table 18.10 Value of Constant *K_e*

Propeller type or machinery	CPP or Electric or Hydraulic propulsion machinery	FPP
1 Propeller	2.03	2.26
2 Propellers	1.44	1.60
3 Propellers	1.18	1.31

D_p : Diameter (*m*) of the propeller

R_{CH} : The resistance (*N*) of the ship in a channel with brash ice and a consolidated layer

$$R_{CH} = C_1 + C_2 + C_3 C_\mu (H_F + H_M)^2 (B + C_\psi H_F) + C_4 L_{PAR} H_F^2 + C_5 (LT/B^2)^3 (A_{wf}/L)$$

L : Length (*m*) of the ship between the perpendiculars on the *UIWL*

B : Maximum breadth (*m*) of the ship on the *UIWL*

T : Actual ice class draughts (*m*) of the ship, in general being a draught amidships of length *L_f* corresponding to the *UIWL* according to **1.2.1(23)** and a draught amidships of length *L_f* corresponding to the *LIWL* according to **1.2.1(24)**.

If the value of the term $(LT/B^2)^3$ is less than 5, the value 5 is to be used and if the value of the term is more than 20, the value 20 is to be used.

L_{PAR} : Length (*m*) of the parallel midship body, measured horizontally between the fore and aft ends of the flat side on the waterline at the actual ice class draught, see **Fig. 18.4**

L_{BOW} : Length (*m*) of the bow, measured horizontally between the fore end of the flat side on the waterline at the actual ice class draught and the fore perpendicular at the *UIWL*, see **Fig. 18.4**.

A_{wf} : Area (*m*²) of the waterline of the bow at the actual ice class draught, see **Fig. 18.4**.

$\psi = \arctan(\tan \varphi_2 / \sin \alpha)$ (*deg*)

$\varphi_1, \varphi_2, \alpha$: The angle (*deg*) between the ship and the water plane at the actual ice class draught, see **Fig. 18.4**.
If the ship has a bulbous bow then φ_1 is taken as 90 *degrees*.

C₁ and *C₂* : Coefficient taken into account a consolidated upper layer of the brash ice and are to be taken as the followings.

(1) For *IA Super* ice class ships

$$C_1 = f_1 B L_{PAR} / (2T/B + 1) + (1 + 0.021\phi_1)(f_2 B + f_3 L_{BOW} + f_4 B L_{BOW})$$

$$C_2 = (1 + 0.063\phi_1)(g_1 + g_2 B) + g_3(1 + 1.2T/B)B^2/\sqrt{L}$$

(2) For IA, IB, IC and ID ice class ships

$$C_1 = 0$$

$$C_2 = 0$$

C_3, C_4 and C_5 : Value given in **Table I8.11**

C_μ : Value given by the following formula, but in no case less than 0.45

$$C_\mu = 0.15\cos\phi_2 + \sin\psi\sin\alpha$$

C_ψ : Value given by the following formula, but taken as 0 where $\psi \leq 45^\circ$

$$C_\psi = 0.047\psi - 2.115$$

$f_1, f_2, f_3, f_4, g_1, g_2$ and g_3 : Value given in **Table I8.11**

H_M : Thickness (m) of the brash ice in a channel as given by the followings.

(1) For IA Super and IA ice class ships $H_M = 1.0$

(2) For IB ice class ships $H_M = 0.8$

(3) For IC ice class ships $H_M = 0.6$

(4) For ID ice class ships $H_M = 0.5$

H_F : Thickness (m) of the brash ice layer displaced by the bow as given by the following formula.

$$H_F = 0.26 + (H_M B)^{0.5}$$

Fig. I8.4 Dimensions

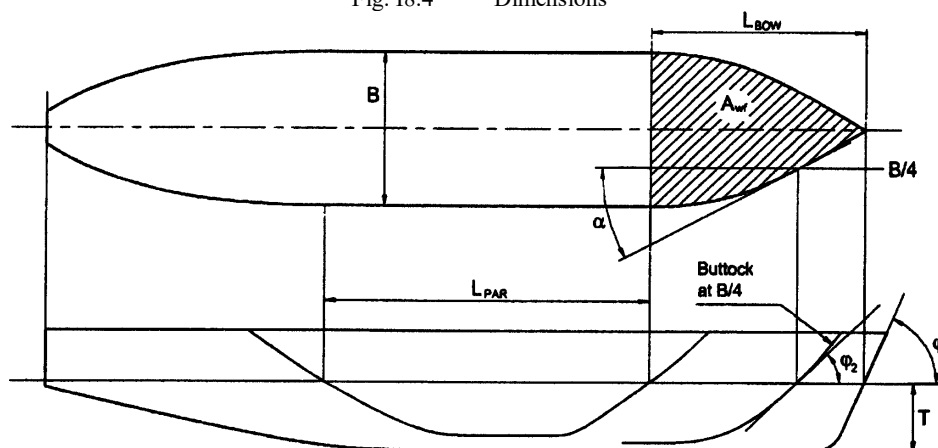

Table I8.11 Value of $f_1, f_2, f_3, f_4, g_1, g_2, g_3, C_3, C_4, C_5$

f_1 :	23.0 (N/m ²)	g_1 :	1,530 (N)	C_3 :	845 (N/m ³)
f_2 :	45.8 (N/m)	g_2 :	170 (N/m)	C_4 :	42 (N/m ³)
f_3 :	14.7 (N/m)	g_3 :	400 (N/m ^{1.5})	C_5 :	825 (N/m)
f_4 :	29.0 (N/m ²)				

2 Special Requirements for Existing Ships

For IA Super and IA ice class ships which are at beginning stage of construction before 1 September 2003, the engine output (H) is to comply with the requirements specified in -1 above or equivalent requirements by 1 January in the year when 20 years have elapsed since the year the ship was delivered. If the ship does not comply with the requirements specified in -1 on the date given above, the highest lower ice class for which the engine output is sufficient can be confirmed for the ship. When, for an existing ship, values for some of the hull form parameters required for the calculation method specified in -1 above are difficult to obtain, the following alternative formulae may be used. The dimensions of the ship, defined below, are measured on the *UIWL* as defined in **1.2.1(23)**.

$$H = K_e \frac{(R_{CH}/1000)^{3/2}}{D_p}$$

H : Engine output (kW)

K_e : Constant given in **Table 18.10**

D_P : Diameter of the propeller (m)

R_{CH} : The resistance of the ship in a channel with brash ice and a consolidated layer (N)

$$R_{CH} = C_1 + C_2 + C_3(H_F + H_M)^2(B + 0.658H_F) + C_4LH_F^2 + C_5(LT/B^2)^3(B/4)$$

L : Length (m) of the ship between the perpendiculars

B : Maximum breadth (m) of the ship

T : Actual ice class draught (m) of the ship

If the value of the term $(LT/B^2)^3$ is less than 5, the value 5 is to be used and if the value of the term is more than 20, the value 20 is to be used.

C_1 and C_2 : Coefficient taken into account a consolidated upper layer of the brash ice and are to be taken as the followings.

- (1) For *IA Super* ice class ships and ice class ships with a bulbous bow

$$C_1 = f_1BL/(2T/B + 1) + 2.89(f_2B + f_3L + f_4BL)$$

$$C_2 = 6.67(g_1 + g_2B) + g_3(1 + 1.2T/B)B^2/\sqrt{L}$$

- (2) For *IA Super* ice class ships and ice class ships without a bulbous bow

$$C_1 = f_1BL/(2T/B + 1) + 1.84(f_2B + f_3L + f_4BL)$$

$$C_2 = 3.52(g_1 + g_2B) + g_3(1 + 1.2T/B)B^2/\sqrt{L}$$

- (3) For *IA* ice class ships

$$C_1 = 0 \text{ and } C_2 = 0$$

$f_1, f_2, f_3, f_4, g_1, g_2, g_3, C_3, C_4,$ and C_5 : Value given in **Table 18.12**

H_M : Thickness (m) of the brash ice in a channel as given by the followings.

$$H_M = 1.0$$

H_F : Thickness (m) of the brash ice layer displaced by the bow as given by the following formula.

$$H_F = 0.26 + (H_MB)^{0.5}$$

Table 18.12 Value of $f_1, f_2, f_3, f_4, g_1, g_2, g_3, C_3, C_4, C_5$

f_1 :	10.3 (N/m^2)	g_1 :	1,530 (N)	C_3 :	460 (N/m^3)
f_2 :	45.8 (N/m)	g_2 :	170 (N/m)	C_4 :	18.7 (N/m^3)
f_3 :	2.94 (N/m)	g_3 :	400 ($N/m^{1.5}$)	C_5 :	825 (N/m)
f_4 :	5.8 (N/m^2)				

3 For ships having features of which, there is ground to assume that they will improve the performance of the ship when navigation in ice, the values for K_e or R_{CH} defined in **-1** and **-2** above may be obtained from detailed calculations or model tests provided that it gives a minimum speed of 5 *knots* in brash ice channels as specified in the following **(1)** to **(5)**:

- (1) For *IA Super* ice class ships: 1.0m of the brash ice and a 0.1m thick consolidated layer of ice
- (2) For *IA* ice class ships: 1.0m of the brash ice
- (3) For *IB* ice class ships: 0.8m of the brash ice
- (4) For *IC* ice class ships: 0.6m of the brash ice
- (5) For *ID* ice class ships: 0.5m of the brash ice

8.4.3 Rudders and Steering Arrangements*

1 The rudder scantlings of rudder post, rudder stock, pintles, steering gear, etc. are to comply with the requirements in **Chapter 13, Part 1, Part C** and **Chapter 15, Part D**. However, for *IA Super*, *IA*, *IB* and *IC* ice class ships, the maximum service speed of the ship to be used in these calculations is not to be taken less than that given in the **Table 18.13**.

2 For *IA Super*, *IA*, *IB* and *IC* ice class ships, the local scantlings of rudders are to be determined assuming that the whole rudder belongs to the ice belt. The rudder plating and frames are to be designed using the ice pressure for the plating and frames in the midbody region.

3 For *IA Super* and *IA* ice class ships, the rudder stock and the upper part of the rudder are to be protected from direct contact with intact ice by either an ice knife that extends below the *LIWL* or by equivalent means. Special consideration is to be given to the design of the rudder and the ice knife for ships with flap-type rudders.

4 For *IA Super* and *IA* ice class ships, the rudders and steering arrangements are to be designed as follows to endure the loads that work on the rudders by the ice when backing into an ice ridge.

- (1) Relief valves for hydraulic pressure are to be installed.
- (2) The components of the steering gear (e.g. rudder stock, rudder coupling, rudder horn etc.) are to be dimensioned to withstand loads causing yield stresses within the required diameter of the rudder stock.
- (3) Suitable arrangements such as rudder stoppers are to be installed.

Class	Speed (<i>kt</i>)
<i>IA Super</i>	20
<i>IA</i>	18
<i>IB</i>	16
<i>IC</i>	14

8.5 Design Loads of Propulsion Units (Ice Classes *IA Super*, *IA*, *IB* and *IC*)

8.5.1 General

1 The requirements in 8.5 apply to *IA Super*, *IA*, *IB* and *IC* ice class ships.

2 In the design of the propeller, propulsion shafting system and power transmission system, the following are to be taken into account.

- (1) Maximum backward blade force
- (2) Maximum forward blade force
- (3) Maximum blade spindle torque
- (4) Maximum propeller ice torque
- (5) Maximum propeller ice thrust
- (6) Design torque on propulsion shafting system
- (7) Maximum thrust on propulsion shafting system
- (8) Blade failure load

3 The loads specified in -2 above are to comply with the following:

- (1) The ice loads cover open and ducted-type propellers with a controllable pitch or fixed pitch blades (including propellers of azimuthing thrusters). However, the load models of these loads do not include propeller/ice interaction loads when ice enters the propeller of a turned azimuthing thruster from the side (radially).
- (2) The given loads in this chapter are expected, single occurrence, maximum values for the whole ships service life for normal operation conditions. The loads do not cover off-design operational conditions, for example when a stopped propeller is dragged through ice.
- (3) The loads are total loads (unless otherwise stated) during interaction and are to be applied separately (unless otherwise stated) and are intended for component strength calculations only.

4 Design Loads of Propellers

- (1) The loads given are intended for component strength calculations only and are total loads including ice-induced loads and hydrodynamic loads during propeller/ice interaction. The presented maximum loads are based on a worst case scenario that occurs once during the service life of the ship.
- (2) The F_b and F_f specified in 8.5.2 and 8.5.3 originate from different propeller/ice interaction phenomena, and do not occur simultaneously. Hence, they are to be applied separately to one blade.
- (3) If the highest point of the propeller is not at a depth of at least h_0 below the water surface when the ship is in the ballast condition, the propulsion system is to be designed according to Ice Class *IA* for Ice Classes *IB* and *IC*.

5 The local strength of the thruster (azimuthing and fixed) body are to be sufficient to withstand local ice pressure when the thruster body is designed for extreme loads.

8.5.2 Maximum Backward Blade Force

1 The maximum backward blade force which bends a propeller blade backwards when a propeller mills an ice block while rotating ahead is to be given by the following formulae:

(1) For open propellers:

when $D \leq D_{limit} = 0.85(H_{ice})^{1.4}(m)$

$$F_b = 27 \left(\frac{n}{60} D \right)^{0.7} \left(\frac{EAR}{Z} \right)^{0.3} D^2 \text{ (kN)}$$

when $D > D_{limit} = 0.85(H_{ice})^{1.4}(m)$

$$F_b = 23(H_{ice})^{1.4} \left(\frac{n}{60} D \right)^{0.7} \left(\frac{EAR}{Z} \right)^{0.3} D \text{ (kN)}$$

(2) For ducted propellers:

when $D \leq D_{limit} = 4H_{ice}(m)$

$$F_b = 9.5 \left(\frac{n}{60} D \right)^{0.7} \left(\frac{EAR}{Z} \right)^{0.3} D^2 \text{ (kN)}$$

when $D > D_{limit} = 4H_{ice}(m)$

$$F_b = 66(H_{ice})^{1.4} \left(\frac{n}{60} D \right)^{0.7} \left(\frac{EAR}{Z} \right)^{0.3} D^{0.6} \text{ (kN)}$$

where

F_b : Maximum backward blade force for the ship's service life (kN)

Direction of the backward blade force resultant taken perpendicular to chord line at radius $0.7R$. (See [Fig. 18.5](#))

H_{ice} : Ice thickness (m) specified in [Table 18.14](#).

D : Propeller diameter (m)

EAR : Expanded blade area ratio

d : external diameter of propeller hub (at propeller plane) (m)

Z : number of propeller blades

n : Nominal rotational propeller speed (rpm) at maximum continuous revolutions in free running condition for controllable pitch propellers and 85% of the nominal rotational propeller speed at maximum continuous revolutions in free running condition for fixed pitch propellers

Table 18.14 The Thickness of the Ice Block H_{ice}

	LA Super	LA	IB	IC
Thickness of the design maximum ice block entering the propeller H_{ice} (m)	1.75	1.5	1.2	1.0

2 The maximum backward blade force F_b is to be applied as a uniform pressure distribution to an area of the blade for the following load cases:

(1) In the case of open propellers:

(a) The F_b specified in **-1(1)** above is to be applied to an area from $0.6R$ to the tip and from the blade leading edge to a value 0.2 of the chord length. (See Load Case 1 in [Table 4.2.2-2](#) of [Chapter 4](#) of [Annex 1](#) "Special Requirements for the Materials, Hull Structures, Equipment and Machinery of Polar Class Ships")

(b) A load equal to 50% of the F_b specified in **-1(1)** above is to be applied to the propeller tip area outside of $0.9R$. (See Load Case 2 in [Table 4.2.2-2](#) of [Chapter 4](#) of [Annex 1](#) "Special Requirements for the Materials, Hull Structures, Equipment and Machinery of Polar Class Ships")

(c) In the case of reversible propellers, a load equal to 60% of the F_b specified in **-1(1)** above is to be applied to an area from $0.6R$ to the tip and from the blade trailing edge to a value 0.2 of the chord length. (See load case 5 in [Table 4.2.2-2](#) of

Chapter 4 of Annex 1 “Special Requirements for the Materials, Hull Structures, Equipment and Machinery of Polar Class Ships”)

- (2) In the case of ducted propellers:
- (a) The F_b specified in -1(2) above is to be applied to an area from $0.6R$ to the tip and from the blade leading edge to a value 0.2 of the chord length. (See Load Case 1 in Table 4.2.2-3 of Chapter 4 of Annex 1 “Special Requirements for the Materials, Hull Structures, Equipment and Machinery of Polar Class Ships”)
- (b) In the case of reversible propellers, a load equal to 60% of the F_b specified in -1(2) above is to be applied to an area from $0.6R$ to the tip and from the blade trailing edge to a value 0.2 of the chord length. (See load case 5 in Table 4.2.2-3 of Chapter 4 of Annex 1 “Special Requirements for the Materials, Hull Structures, Equipment and Machinery of Polar Class Ships”)

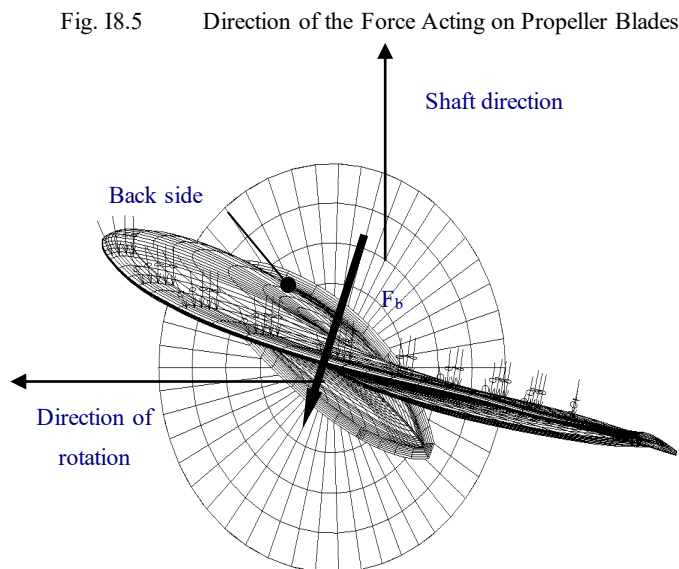

8.5.3 Maximum Forward Blade Force

1 The maximum forward blade force which bends a propeller blade forwards when a propeller interacts with an ice block while rotating ahead is to be given by the following formulae:

- (1) For open propellers:

$$\text{when } D \leq D_{\text{limit}} = \frac{2}{(1-d/D)} H_{\text{ice}} \text{ (m)}$$

$$F_f = 250 \left(\frac{EAR}{Z} \right) D^2 \text{ (kN)}$$

$$\text{when } D > D_{\text{limit}} = \frac{2}{(1-d/D)} H_{\text{ice}} \text{ (m)}$$

$$F_f = 500 H_{\text{ice}} \left(\frac{EAR}{Z} \right) \left(\frac{1}{1-d/D} \right) D \text{ (kN)}$$

- (2) For ducted propellers:

$$\text{when } D \leq D_{\text{limit}} = \frac{2}{(1-d/D)} H_{\text{ice}} \text{ (m)}$$

$$F_f = 250 \left(\frac{EAR}{Z} \right) D^2 \text{ (kN)}$$

$$\text{when } D > D_{\text{limit}} = \frac{2}{(1-d/D)} H_{\text{ice}} \text{ (m)}$$

$$F_f = 500 H_{\text{ice}} \left(\frac{EAR}{Z} \right) \left(\frac{1}{1-d/D} \right) D \text{ (kN)}$$

where

F_f : The maximum forward blade force for the ship's service life (kN)

Direction of the forward blade force resultant taken perpendicular to chord line at radius $0.7R$.

H_{ice} , D , EAR , d and Z : As specified in **8.5.2**

2 The maximum forward blade force F_f is to be applied as a uniform pressure distribution to an area of the blade for the following load cases:

- (1) In the case of open propellers:
 - (a) The F_f specified in **-1(1)** above is to be applied to an area from $0.6R$ to the tip and from the blade leading edge to a value 0.2 of the chord length. (See Load Case 3 in **Table 4.2.2-2** of **Chapter 4** of **Annex 1** “Special Requirements for the Materials, Hull Structures, Equipment and Machinery of Polar Class Ships”)
 - (b) A load equal to 50% of the F_f specified in **-1(1)** above is to be applied to the propeller tip area outside of $0.9R$. (See Load Case 4 in **Table 4.2.2-2** of **Chapter 4** of **Annex 1** “Special Requirements for the Materials, Hull Structures, Equipment and Machinery of Polar Class Ships”)
 - (c) In the case of reversible propellers, a load equal to 60% of the F_f specified in **-1(1)** above is to be applied to an area from $0.6R$ to the tip and from the blade trailing edge to a value 0.2 of the chord length. (See Load Case 5 in **Table 4.2.2-2** of **Chapter 4** of **Annex 1** “Special Requirements for the Materials, Hull Structures, Equipment and Machinery of Polar Class Ships”)
- (2) In the case of ducted propellers:
 - (a) The F_f specified in **-1(2)** above is to be applied to an area from $0.6R$ to the tip and from the blade leading edge to a value 0.5 of the chord length. (See Load Case 3 in **Table 4.2.2-3** of **Chapter 4** of **Annex 1** “Special Requirements for the Materials, Hull Structures, Equipment and Machinery of Polar Class Ships”)
 - (b) In the case of reversible propellers, a load equal to 60% of the F_f specified in **-1(2)** above is to be applied to an area from $0.6R$ to the tip and from the blade trailing edge to a value 0.2 of the chord length. (See Load Case 5 in **Table 4.2.2-3** of **Chapter 4** of **Annex 1** “Special Requirements for the Materials, Hull Structures, Equipment and Machinery of Polar Class Ships”)

8.5.4 Maximum Blade Spindle Torque

The spindle torque around the spindle axis of the blade fitting is to be calculated both for the load cases specified in **8.5.2** and **8.5.3** for F_b and F_f . In cases where these spindle torque values are less than the default value obtained from the following formula, the default value is to be used.

$$Q_{smax} = 0.25FC_{0.7} \text{ (kNm)}$$

where

$C_{0.7}$: Length (m) of the blade chord at radius $0.7R$

F : Either F_b determined in **8.5.2-1** or F_f determined in **8.5.3-1**, whichever has the greater absolute value (kN).

8.5.5 Frequent Distributions for Propellers Blade Loads

1 A Weibull-type distribution (probability that F_{ice} exceeds $(F_{ice})_{max}$), as given in **Fig. 18.6**, is to be used for the fatigue design of blades.

$$P\left(\frac{F_{ice}}{(F_{ice})_{max}} \geq \frac{F}{(F_{ice})_{max}}\right) = \exp\left(-\left(\frac{F}{(F_{ice})_{max}}\right)^k \ln(N_{ice})\right)$$

where

F_{ice} : Random variable for ice loads (kN) on the blade, and meet the requirements $0 \leq F_{ice} \leq (F_{ice})_{max}$

$(F_{ice})_{max}$: Maximum ice load for the ship's service life (kN)

k : Shape parameter for Weibull-type distribution The following definitions apply:

Open propeller: $k=0.75$

Ducted propeller: $k=1.0$

N_{ice} : Total number of ice loads on a propeller blade for the ship's service life

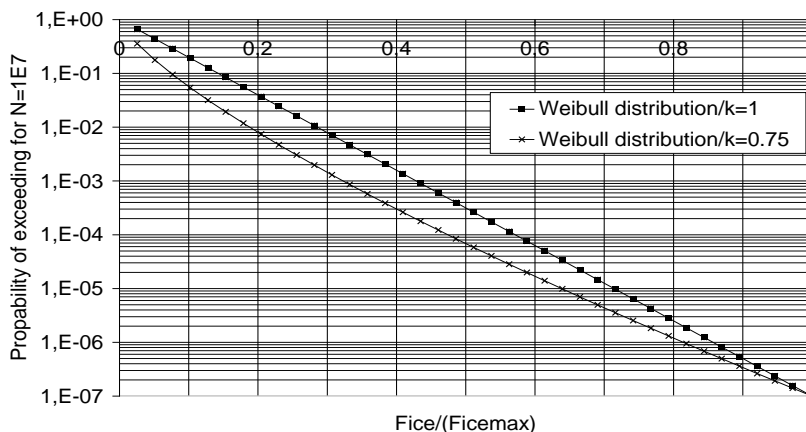
Fig. I8.6 The Weibull-type Distribution (probability that F_{ice} exceeds $(F_{ice})_{max}$) that is Used for Fatigue Designs

2 Number of ice loads

- (1) The number of load cycles per propeller blade in the load spectrum is to be determined according to the formula:

$$N_{ice} = k_1 k_2 k_3 N_{class} \frac{n_n}{60}$$

where

N_{class} : Reference number of loads for ice classes, as specified in [Table I8.15](#)

n_n : Nominal propeller rotational speed at maximum continuous revolutions in free running condition (*rpm*)

k_1 : Propeller location factor, as specified in [Table I8.16](#)

k_2 : The submersion factor k_2 is determined from the equation.

$$0.8 - f \quad : f < 0$$

$$k_2 = 0.8 - 0.4f \quad : 0 \leq f \leq 1$$

$$0.6 - 0.2f \quad : 1 < f \leq 2.5$$

$$0.1 \quad : f > 2.5$$

where

$$f = \frac{h_a - H_{ice}}{D/2} - 1$$

k_3 : The propulsion machinery type factor k_3 is as follows.

Fixed propulsor: $k_3 = 1$

Azimuthing propulsor: $k_3 = 1.2$

h_a : The depth of the propeller centreline at the lower ice waterline (*LIWL*) of the ship (*m*)

H_{ice} and D : As specified in [8.5.2](#)

- (2) In the case of components that are subject to loads resulting from propeller/ice interaction with all of the propeller blades, the number of load cycles (N_{ice}) is to be multiplied by the number of propeller blades (Z).

 Table I8.15 Reference Number of Loads for Ice Classes N_{class}

Class	IA Super	IA	IB	IC
impacts in life / ($n_n/60$)	$9 \cdot 10^6$	$6 \cdot 10^6$	$3.4 \cdot 10^6$	$2.1 \cdot 10^6$

 Table I8.16 Propeller Location Factor k_l

factor	Centre propeller Bow first operation	Wing propeller Bow first operation	Pulling propeller (wing and centre) Bow propeller or Stern first operation
k_l	1	2	3

8.5.6 Maximum Propeller Ice Thrust

The maximum propeller ice thrust applied to a propeller is to be given by the following formulae:

- (1) Maximum backward propeller ice thrust

$$T_b = 1.1 F_b \text{ (kN)}$$

- (2) Maximum forward propeller ice thrust

$$T_f = 1.1 F_f \text{ (kN)}$$

where

F_b : Maximum backward blade force for the ship's service life, as specified in [8.5.2-1](#)

F_f : Maximum forward blade force for the ship's service life, as specified in [8.5.3-1](#)

T_b : Maximum backward propeller ice thrust (kN)

T_f : Maximum forward propeller ice thrust (kN)

8.5.7 Design Thrust along Propulsion Shaft Lines

The design thrust along the propeller shaft line is to be given by the following formulae:

- (1) Maximum shaft thrust forwards:

$$T_r = T + 2.2T_f \text{ (kN)}$$

- (2) Maximum shaft thrust backwards:

$$T_r = 1.5T_b \text{ (kN)}$$

where:

T_b and T_f : Maximum propeller ice thrust (kN) determined in [8.5.6](#)

T : Propeller bollard thrust (kN). If not known, T is to be taken as specified in [Table I8.17](#)

Table I8.17 Value of T

Propeller type	T
Controllable pitch propellers (open)	$1.25 T_n$
Controllable pitch propellers (ducted)	$1.1 T_n$
Fixed pitch propellers driven by turbine or electric motor	T_n
Fixed pitch propellers driven by diesel engine (open)	$0.85 T_n$
Fixed pitch propellers driven by diesel engine (ducted)	$0.75 T_n$

Note:

T_n : Nominal propeller thrust (kN) at maximum continuous revolutions in free running open water conditions

8.5.8 Maximum Propeller Ice Torque

The maximum propeller ice torque applied to the propeller during the service life of the ship is to be given by the following formulae:

- (1) For open propellers:

when $D \leq D_{\text{limit}} = 1.8H_{\text{ice}}$ (m)

$$Q_{\text{max}} = 10.9 \left(1 - \frac{d}{D}\right) \left(\frac{P_{0.7}}{D}\right)^{0.16} \left(\frac{n}{60}D\right)^{0.17} D^3 \text{ (kNm)}$$

when $D > D_{\text{limit}} = 1.8H_{\text{ice}}$ (m)

$$Q_{\text{max}} = 20.7(H_{\text{ice}})^{1.1} \left(1 - \frac{d}{D}\right) \left(\frac{P_{0.7}}{D}\right)^{0.16} \left(\frac{n}{60}D\right)^{0.17} D^{1.9} \text{ (kNm)}$$

- (2) For ducted propellers:

when $D \leq D_{\text{limit}} = 1.8H_{\text{ice}}$ (m)

$$Q_{\text{max}} = 7.7 \left(1 - \frac{d}{D}\right) \left(\frac{P_{0.7}}{D}\right)^{0.16} \left(\frac{n}{60}D\right)^{0.17} D^3 \text{ (kNm)}$$

when $D > D_{\text{limit}} = 1.8H_{\text{ice}}$ (m)

$$Q_{\text{max}} = 14.6(H_{\text{ice}})^{1.1} \left(1 - \frac{d}{D}\right) \left(\frac{P_{0.7}}{D}\right)^{0.16} \left(\frac{n}{60}D\right)^{0.17} D^{1.9} \text{ (kNm)}$$

where:

H_{ice} , D and d : As specified in **8.5.2**

$P_{0.7}$: Propeller pitch (m) at $0.7R$

In the case of controllable pitch propellers, $P_{0.7}$ is to correspond to maximum continuous revolutions at the bollard condition. If not known, $P_{0.7}$ is to be taken as $0.7 P_{0.7n}$, where $P_{0.7n}$ is the propeller pitch at maximum continuous revolutions at a free running condition.

n : Rotational propeller speed (rpm) at maximum continuous revolutions in the bollard condition

If not known, n is to be taken as specified in **Table 18.18**.

Table 18.18 Rotational Propeller Speed n

Propeller type	n
Controllable pitch propellers	n_n
Fixed pitch propellers driven by turbine or electric motor	n_n
Fixed pitch propellers driven by diesel engine	$0.85n_n$

Note:

In **Table 18.18**, n_n is nominal rotational speed (rpm) at maximum continuous revolutions at the free running open water condition.

8.5.9 Design Torque on Propulsion Shafting System

1 Design torque along propeller shaft line

- (1) If there is not a predominant torsional resonance in the operational speed range or in the range 20% above and 20% below the maximum operating speed (bollard condition), the following estimation of the maximum torque can be used:

Directly coupled two stroke diesel engines without flexible coupling

$$Q_{peak} = Q_{emax} + Q_{vib} + Q_{max} \frac{I_e}{I_t} \quad (kNm)$$

and other plants

$$Q_{peak} = Q_{emax} + Q_{max} \frac{I_e}{I_t} \quad (kNm)$$

Q_{peak} : maximum response torque (kNm)

Q_{emax} : maximum engine torque (kNm)

If the maximum torque, Q_{emax} , is not known, it is to be taken as specified in **Table 18.19**

Q_{vib} : vibratory torque at considered component, taken from frequency domain open water torque vibration calculation (TVC)

I_e : equivalent mass moment of inertia of all parts on the engine side of the component under consideration (kgm^2)

I_t : equivalent mass moment of inertia of the whole propulsion system (kgm^2)

- (2) If there is first blade order torsional resonance in the operational speed range or in the range 20% above and 20% below the maximum operating speed (bollard condition), the design torque (Q_{peak}) of the shaft component is to be determined by means of torsional vibration analysis of the propulsion line. There are two alternative ways of performing the dynamic analysis as the following **(a)** and **(b)**.

- (a) Time domain calculation for estimated milling sequence excitation (**8.5.9-2.**)
 (b) Frequency domain calculation for blade orders sinusoidal excitation (**8.5.9-3.**)

Table I8.19 Maximum Engine Torque Q_{emax}

Propeller type	Q_{emax}
Propellers driven by electric motor	Q_{motor}
CP propellers not driven by electric motor	Q_n
FP propellers driven by turbine	Q_n
FP propellers driven by diesel engine	$0.75 Q_n$

Notes:

Q_{motor} : Electric motor peak torque (kNm)

Q_n : Nominal torque at maximum continuous revolutions in free running condition (kNm)

2 Time domain calculation

Time domain calculations are to be calculated for the maximum continuous revolutions condition, maximum continuous revolutions bollard conditions and for blade order resonant rotational speeds so that the resonant vibration responses can be obtained. The load sequence given in the following, for a case where a propeller is milling an ice block, are to be used for the strength evaluation of the propulsion line. (The given load sequence is not intended for propulsion system stalling analyses.)

- (1) Diesel engine plants without an elastic coupling are to be calculated at the least favourable phase angle for ice versus engine excitation, when calculated in the time domain.
- (2) The engine firing pulses are to be included in the calculations and their standard steady state harmonics can be used.
- (3) If there is a blade order resonance just above the maximum continuous revolutions speed, calculations are to cover rotational speeds up to 105% of the maximum continuous revolutions speed.
- (4) The propeller ice excitation torque for shaft line transient dynamic analysis in the time domain is to comply with the following requirements:

- (a) The excitation torque is defined as a sequence of blade impacts which are of half sine shape and occur at the blade. The excitation frequency is to follow the propeller rotational speed during the ice interaction sequence. The total ice torque is to be obtained by summing the torques of single ice blade ice impacts taking into account the phase shift. The single ice blade impact is given by the following formulae:

- i) when $0 \leq \varphi - 360x \leq \alpha_i$ (deg)

$$Q(\varphi) = C_q Q_{max} \sin(\varphi(180/\alpha_i))$$

- ii) when $\alpha_i \leq \varphi - 360x \leq 360$ (deg)

$$Q(\varphi) = 0$$

where

φ : Rotation angle from when the first impact occurs

x : Integer revolutions from the time of first impact

Q_{max} : Maximum torque on the propeller as specified in 8.5.8. Q_{max} may be taken as a constant value in the complete speed range. When considerations at specific shaft speeds are performed, a relevant Q_{max} may be calculated using the relevant speed according to 8.5.8 and 8.5.9.

C_q : As specified in Table I8.20

α_i : Duration of propeller blade/ice interaction expressed in rotation angle as specified in Table I8.20

(See Fig. I8.7)

- (b) The number of propeller revolutions and the number of impacts during the milling sequence are to be given by the following formulae. For bow propellers, the number of propeller revolutions and the number of impacts during the milling sequence are subject to special consideration.

- i) The number of propeller revolutions:

$$N_Q = 2H_{ice}$$

- ii) The number of impacts:

$$ZN_Q$$

Where

H_{ice} : As specified in Table I8.15

Z : Number of propeller blades

An illustration of all excitation cases for different numbers of blades is given in [Fig. 18.8](#) and [Fig. 18.9](#).

- (c) A dynamic simulation is to be performed for all excitation cases at the operational rotational speed range. For a fixed pitch propeller propulsion plant, a dynamic simulation is also to cover the bollard pull condition with a corresponding rotational speed assuming the maximum possible output of the engine.
- (d) For the consideration of loads, the maximum occurring torque during the speed drop process is to be used.
- (e) For the time domain calculation, the simulated response torque typically includes the engine mean torque and the propeller mean torque. If this is not the case, the response torques are to be obtained using the following formula:

$$Q_{peak} = Q_{emax} + Q_{rtd}$$

Where

Q_{rtd} : Maximum simulated torque obtained from the time domain analysis

Fig. 18.7 Schematic ice torque due to a single blade ice impact as a function of the propeller rotation angle

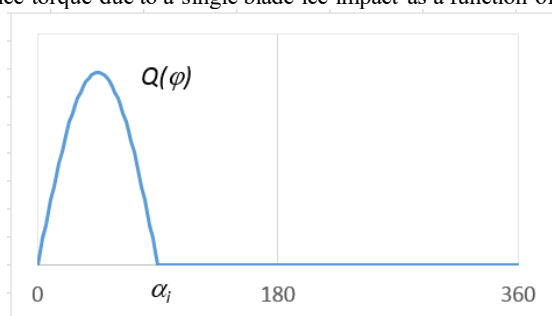

Table I8.20 Values of C_q and a_i

Torque excitation	Propeller-ice interaction	C_q	a_i (deg)			
			$Z=3$	$Z=4$	$Z=5$	$Z=6$
Case 1	Single ice block	0.75	90	90	72	60
Case 2	Single ice block	1.0	135	135	135	135
Case 3	Two ice blocks (phase shift $360/(2 \cdot Z)$ deg.)	0.5	45	45	36	30
Case 4	Single ice block	0.5	45	45	36	30

Note:

Total ice torque is obtained by summing the torque of single blades, while taking account of the phase shift $360\text{deg./}Z$ (See [Fig. 18.8](#) and [Fig. 18.9](#)). At the beginning and end of the milling sequence (within the calculated duration), linear ramp functions are to be used to increase C_q to its maximum value within one propeller revolution and vice versa to decrease it to zero (see the examples of different Z numbers in [Fig. 18.8](#) and [Fig. 18.9](#)).

Fig. I8.8 Example of the Shape of the Propeller Ice Torque Excitation (three and four bladed propeller)

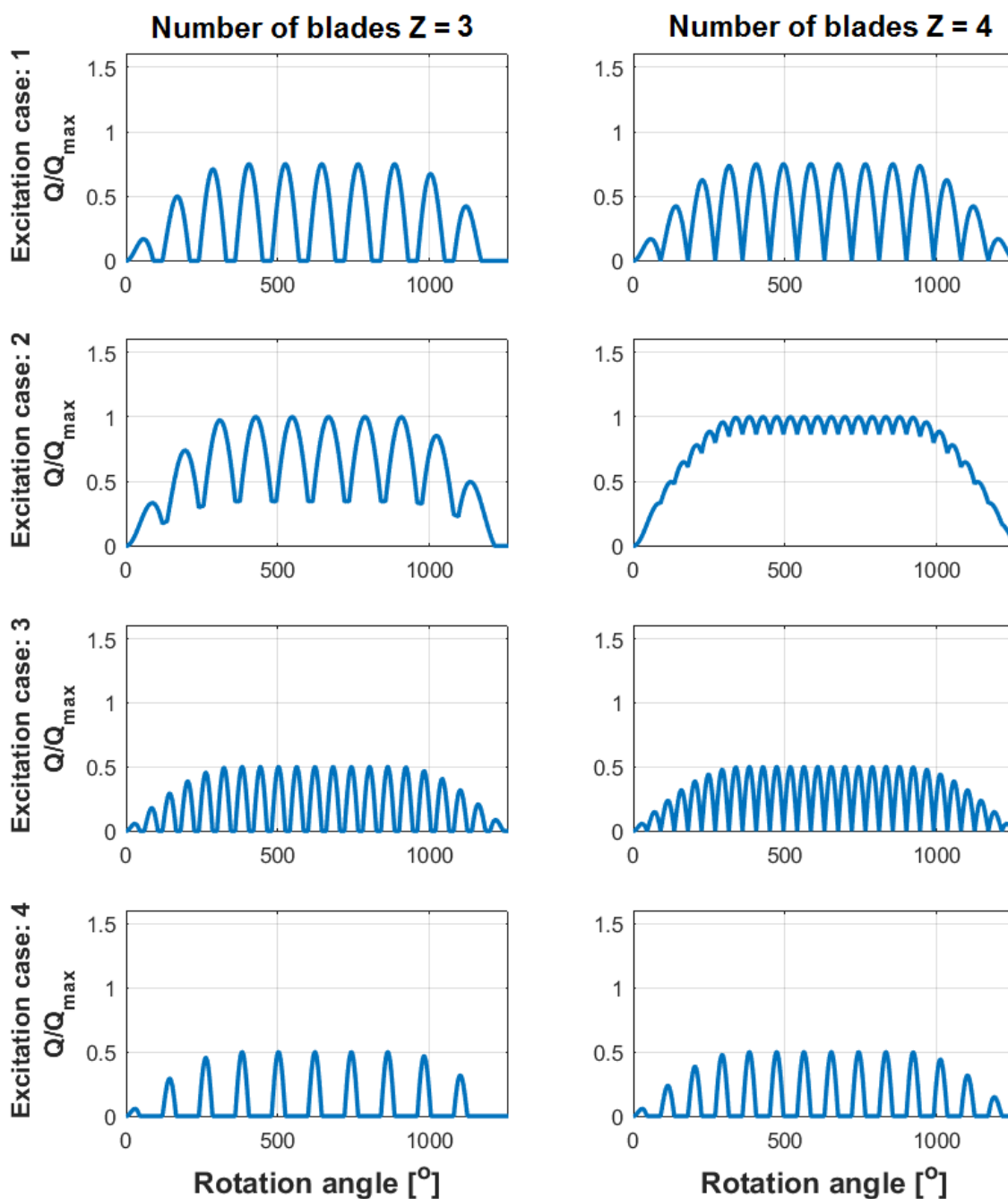
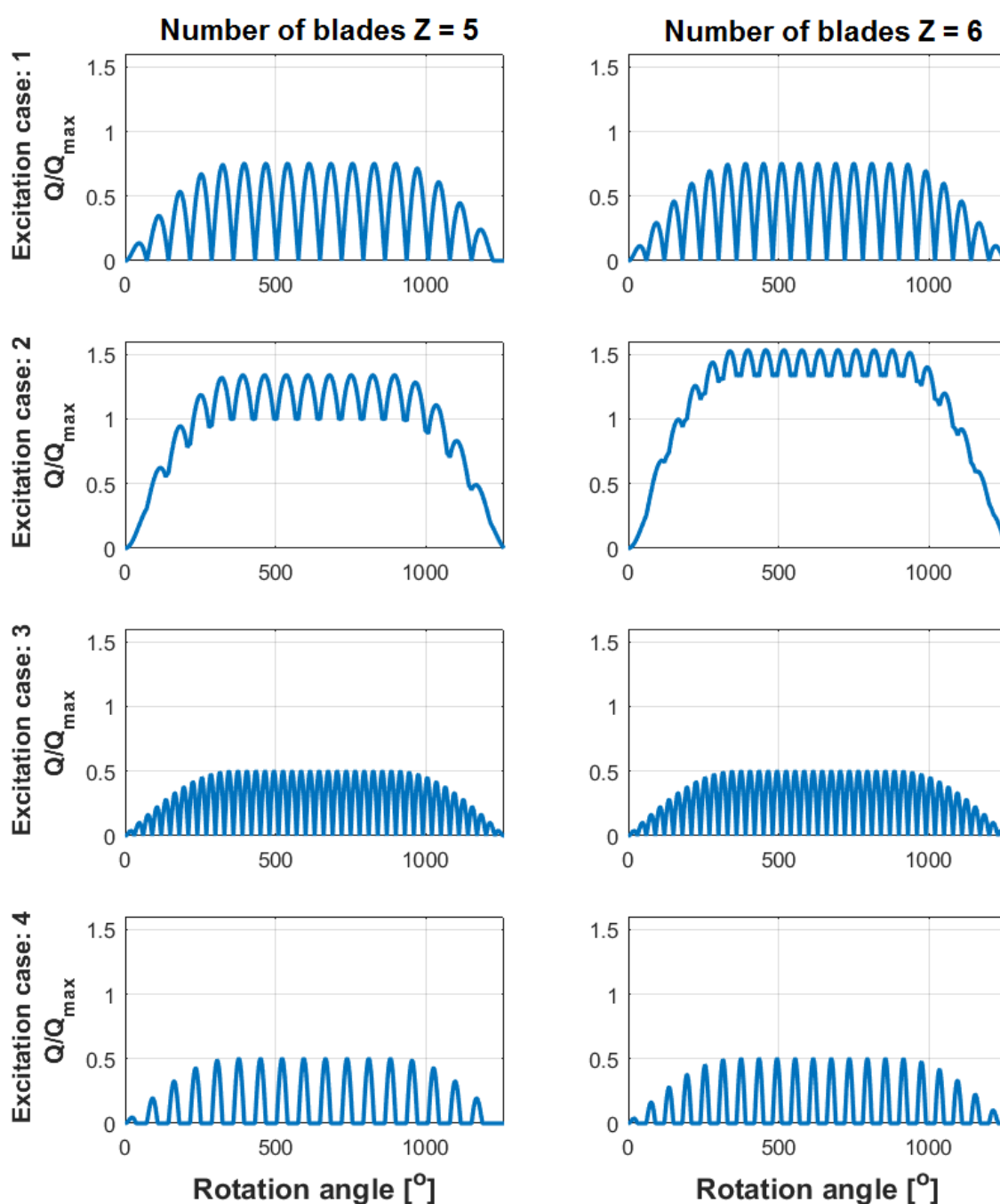

Fig. I8.9 Example of the Shape of the Propeller Ice Torque Excitation (five and six bladed propeller)



3 Frequency domain calculation

For frequency domain calculations, blade order and twice-the-blade-order excitation may be used. The amplitudes for the blade order and twice-the-blade-order sinusoidal excitation have been derived based on the assumption that the time domain half sine impact sequences were continuous, and the Fourier series components for blade order and twice-the-blade-order components have been derived.

The propeller ice torque is then:

$$Q_F(\varphi) = Q_{max}(C_{q0} + C_{q1}\sin(ZE_0\varphi + \alpha_1) + C_{q2}\sin(2ZE_0\varphi + \alpha_2)) \quad (kNm)$$

where

C_{q0} : Mean torque parameter, as specified in [Table I8.21](#)

C_{q1} : First blade order excitation parameter, as specified in [Table I8.21](#)

C_{q2} : Second blade order excitation parameter, as specified in [Table I8.21](#)

α_1, α_2 : Phase angles of the excitation component, as specified in [Table 18.21](#)

φ : Angle of rotation

E_0 : Number of ice blocks in contact, as specified in [Table 18.21](#)

Z : Number of propeller blades

The design torque for the frequency domain excitation case is to be obtained using the formula:

$$Q_{peak} = Q_{emax} + Q_{vib} + (Q_{max}^n C_{q0}) \frac{I_e}{I_t} + Q_{rf1} + Q_{rf2}$$

where

Q_{vib} : Vibratory torque at considered component, taken from frequency domain open water torque vibration calculation (TVC)

Q_{max}^n : Maximum propeller ice torque at the operation speed in consideration

C_{q0} : Value given in [Table 18.21](#)

Q_{rf1} : Blade order torsional response from the frequency domain analysis

Q_{rf2} : Second order blade torsional response from the frequency domain analysis

If the maximum engine torque, Q_{emax} , is not known, it is to be taken as given in [Table 18.19](#). All the torque values have to be scaled to the shaft revolutions for the component in question. The calculation should cover the entire relevant rpm range and the simulation of responses at torsional vibration resonances.

Table 18.21 Values of $C_{q0}, C_{q1}, \alpha_1, C_{q2}, \alpha_2$, and E_0

Number of propeller blades: Z	Torque excitation	C_{q0}	C_{q1}	α_1	C_{q2}	α_2	E_0
3	Case 1	0.375	0.36	-90	0	0	1
	Case 2	0.7	0.33	-90	0.05	-45	1
	Case 3	0.25	0.25	-90	0		2
	Case 4	0.2	0.25	0	0.05	-90	1
4	Case 1	0.45	0.36	-90	0.06	-90	1
	Case 2	0.9375	0	-90	0.0625	-90	1
	Case 3	0.25	0.25	-90	0	0	2
	Case 4	0.2	0.25	0	0.05	-90	1
5	Case 1	0.45	0.36	-90	0.06	-90	1
	Case 2	1.19	0.17	-90	0.02	-90	1
	Case 3	0.3	0.25	-90	0.048	-90	2
	Case 4	0.2	0.25	0	0.05	-90	1
6	Case 1	0.45	0.36	-90	0.05	-90	1
	Case 2	1.435	0.1	-90	0	0	1
	Case 3	0.3	0.25	-90	0.048	-90	2
	Case 4	0.2	0.25	0	0.05	-90	1

4 For time domain calculation specified in -2 and frequency domain calculation specified in -3, further the requirements given in the following (1) and (2) are also to be complied with.

- (1) The aim of time domain torsional vibration simulations is to estimate the extreme torsional load for the ship's lifespan. The simulation model can be taken from the normal lumped mass elastic torsional vibration model, including damping. For a time domain analysis, the model should include the ice excitation at the propeller, other relevant excitations and the mean torques provided by the prime mover and hydrodynamic mean torque in the propeller. The calculations should cover variation of phase between the ice excitation and prime mover excitation. This is extremely relevant to propulsion lines with directly driven combustion engines. Time domain calculations are to be calculated for the maximum continuous revolutions condition, maximum continuous revolutions bollard conditions and for resonant speed, so that the resonant vibration responses can be obtained.

- (2) For frequency domain calculations, the load should be estimated as a Fourier component analysis of the continuous sequence of half sine load sequences. First and second order blade components should be used for excitation.

8.5.10 Blade Failure Loads

1 The blade failure load is to be given by the following formula or alternatively by means of an appropriate stress analysis, reflecting the non-linear plastic material behaviour of the actual blade. In such a case, the blade failure area may be outside the root section. A blade is regarded as having failed if the tip is bent into an offset position by more than 10% of propeller diameter D .

$$F_{ex} = \frac{300ct^2\sigma_{ref1}}{0.8D-2r} \text{ (kN)}$$

where

σ_{ref1} : The reference strength is to be given by the following formula:

$$\sigma_{ref1} = 0.6\sigma_{0.2} + 0.4\sigma_u \text{ (MPa)}$$

where

σ_u : Minimum ultimate tensile strength of blade material (MPa)

$\sigma_{0.2}$: Minimum yield or 0.2% proof strength of blade material (MPa)

c : Chord length of blade section (m)

F_{ex} : ultimate blade load resulting from blade loss through plastic bending (kN)

r : blade section radius (m)

t : Maximum blade section thickness (m)

- 2 The force specified in -1. above is to be acting at $0.8R$ in the weakest direction of the blade.

3 Spindle torque

The maximum spindle torque due to a blade failure load acting at $0.8R$ is to be determined. The force that causes blade failure typically reduces when moving from the propeller centre towards the leading and trailing edges. At a certain distance from the blade centre of rotation, the maximum spindle torque will occur. This maximum spindle torque is to be defined by an appropriate stress analysis or using the equation given below.

$$Q_{sex} = \max(C_{LE0.8}; 0.8C_{TE0.8})C_{spex}F_{ex} \text{ (kNm)}$$

where

$$C_{spex} = C_{sp}C_{fex} = 0.7 \left(1 - \left(\frac{4EAR}{Z} \right)^3 \right)$$

C_{sp} : Non-dimensional parameter taking account of the spindle arm

C_{fex} : Non-dimensional parameter taking account of the reduction of the blade failure force at the location of the maximum spindle torque

$C_{LE0.8}$: Leading edge portion of the chord length at $0.8R$

$C_{TE0.8}$: Trailing edge portion of the chord length at $0.8R$

If C_{spex} is below 0.3, a value of 0.3 is to be used for C_{spex} .

Fig. 18.10 illustrates the spindle torque values due to blade failure loads across the entire chord length.

Fig. 18.10 Schematic figure showing a blade failure load and the related spindle torque when the force acts at a different location on the chord line at radius 0.8R

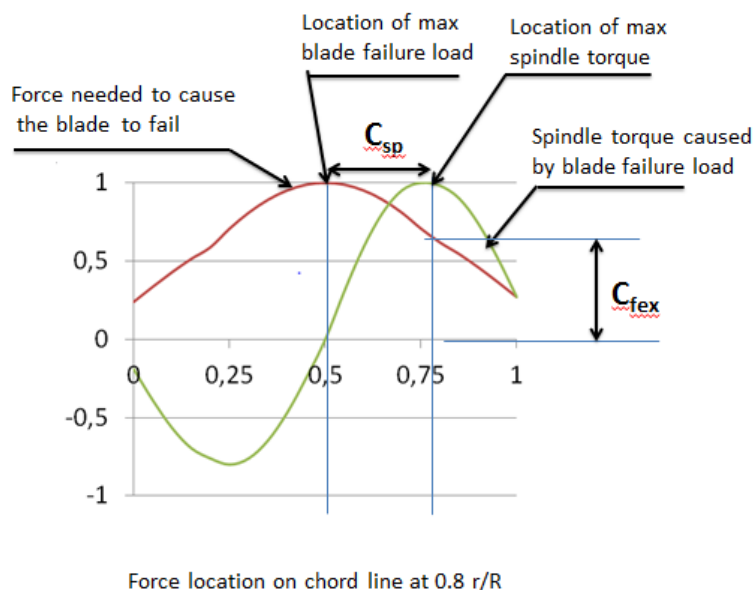

8.6 Design of Propellers and Propulsion Shafting Systems (Ice Classes *IA Super*, *IA*, *IB* and *IC*)

8.6.1 General

- 1 The requirements in 8.6 apply to *IA Super*, *IA*, *IB* and *IC* ice class ships.
- 2 With respect to the design of the propeller and the propulsion shafting system, the following are to be taken into account:
 - (1) Propeller and propulsion shafting systems are to have sufficient strength for the loads specified in 8.5.
 - (2) The blade failure load given in 8.5.10 is not to damage the propulsion shafting system other than the propeller blade itself.
 - (3) Propeller and propulsion shafting systems are to have sufficient fatigue strength.

8.6.2 Propeller Blade Stresses

1 Propeller blade stresses are to be calculated for the design loads given in 8.5.2 and 8.5.3 using Finite Element Analysis. In the case of a relative radius $r/R < 0.5$, the blade stresses for all propellers at their root areas may be calculated by the formula given below. Root area dimensions based on this formula can be accepted even if FEM analysis shows greater stresses at the root area.

$$\sigma_{st} = C_1 \frac{M_{BL}}{100ct^2} \text{ (MPa)}$$

where

$$C_1: \frac{\text{stress obtained with FEM analysis result}}{\text{stress obtained with beam equation}}$$

If the actual value is not available, C_1 should have a value of 1.6.

where

M_{BL} : Blade bending moment (kNm), in the case of a relative radius $r/R < 0.5$, the following:

$$M_{BL} = (0.75 - r/R)RF$$

F : Force F_b or F_f , whichever has greater absolute value.

- 2 The calculated blade stress σ_{st} specified in -1 above is to comply with the following:

$$\frac{\sigma_{ref2}}{\sigma_{st}} \geq 1.3$$

where

σ_{st} : Maximum stress resulting from F_b or F_f (MPa)

σ_u : Ultimate tensile strength of blade material (MPa)

σ_{ref2} : Reference strength (MPa), whichever is lower

$$\sigma_{ref2} = 0.7\sigma_u, \text{ or } \sigma_{ref2} = 0.6\sigma_{0.2} + 0.4\sigma_u$$

3 Fatigue design of propeller blades

- (1) The fatigue design of a propeller blade is based on the estimated load distribution for the service life of the ship and the S-N curve for the blade material. An equivalent stress that produces the same fatigue damage as the expected load distribution is to be calculated and the acceptability criterion for fatigue is to be fulfilled as given in -4-. The equivalent stress is normalised for 10^8 cycles. For materials with a two-slope S-N curve (See Fig. 18.11), the fatigue calculations specified in this section are not required if the following criterion is fulfilled.

$$\sigma_{\text{exp}} \geq B_1 \sigma_{\text{ref}}^{B_2} \log(N_{\text{ice}})^{B_3}$$

where

The coefficients B_1 , B_2 and B_3 are as given in the Table 18.22.

- (2) For the calculation of equivalent stress, two types of S-N curves are to be used.
- Two-slope S-N curve (slopes 4.5 and 10), see Fig. 18.11.
 - One-slope S-N curve (the slope can be chosen), see Fig. 18.12.
- (3) The type of the S-N curve is to be selected to correspond with the material properties of the blade. If the S-N curve is unknown, a two-slope S-N curve is to be used.
- (4) The equivalent fatigue stress for 10^8 stress cycles which produces the same fatigue damage as the load distribution for the service life of the ship, is:

$$\sigma_{\text{fat}} = \rho(\sigma_{\text{ice}})_{\text{max}}$$

where

ρ : Depending on the applicable S-N curve, ρ is to be given by either (5) or (6).

$$(\sigma_{\text{ice}})_{\text{max}} = 0.5((\sigma_{\text{ice}})_{\text{fmax}} - (\sigma_{\text{ice}})_{\text{bmax}})$$

$(\sigma_{\text{ice}})_{\text{max}}$: The mean value of the principal stress amplitudes resulting from forward and backward blade forces at the location being studied.

$(\sigma_{\text{ice}})_{\text{fmax}}$: The principal stress resulting from forward load

$(\sigma_{\text{ice}})_{\text{bmax}}$: The principal stress resulting from backward load

- (5) The calculation of the parameter ρ for a two-slope S-N curve is as follows:

Parameter ρ relates the maximum ice load to the distribution of ice loads according to the following regression formulae:

$$\rho = C_1(\sigma_{\text{ice}})_{\text{max}}^{C_2} \sigma_{\text{fl}}^{C_3} \log(N_{\text{ice}})^{C_4}$$

where

$$\sigma_{\text{fl}} = \gamma_{\varepsilon 1} \gamma_{\varepsilon 2} \gamma_v \gamma_m \sigma_{\text{exp}}$$

σ_{fl} : Characteristic fatigue strength for blade material (MPa)

$\gamma_{\varepsilon 1}$: The reduction factor due to scatter (equal to one standard deviation)

$\gamma_{\varepsilon 2}$: The reduction factor for test specimen size effect

γ_v : The reduction factor for variable amplitude loading

γ_m : The reduction factor for mean stress

σ_{exp} : The mean fatigue strength of the blade material at 10^8 cycles to failure in seawater (MPa)

The following values are to be used as reduction factors if actual values are unavailable:

$$\gamma_{\varepsilon} = \gamma_{\varepsilon 1} \gamma_{\varepsilon 2} = 0.67, \gamma_v = 0.75, \gamma_m = 0.75$$

The coefficients C_1 , C_2 , C_3 , and C_4 are given in Table 18.23. The applicable range of N_{ice} for calculating ρ is $5 \times 10^6 \leq N_{\text{ice}} \leq 10^8$.

- (6) The calculation of the parameter for a constant-slope S-N curve

In the case of materials with a constant-slope S-N curve - see Fig. 18.12 - the ρ factor is to be calculated using the following formula:

$$\rho = \left(G \frac{N_{\text{ice}}}{N_R} \right)^{1/m} (\ln(N_{\text{ice}}))^{-1/k}$$

where

k is the shape parameter of the Weibull distribution, it is as follows:

- $k = 1.0$ for ducted propellers

(b) $k = 0.75$ for open propellers

N_R : The reference number of load cycles ($= 10^8$)

The applicable range of N_{ice} for calculating ρ is $5 \times 10^6 \leq N_{ice} \leq 10^8$.

m : slope for S-N curve in log/log scale

G : Values for the parameter G are given in [Table 18.24](#). Linear interpolation may be used to calculate the G value of m/k ratios other than those given in [Table 18.24](#).

Table 18.22 The Coefficients B_1 , B_2 and B_3

Coefficients	Open propeller	Ducted propeller
B_1	0.00328	0.00223
B_2	1.0076	1.0071
B_3	2.101	2.471

Fig. 18.12 Constant-slope S-N Curve

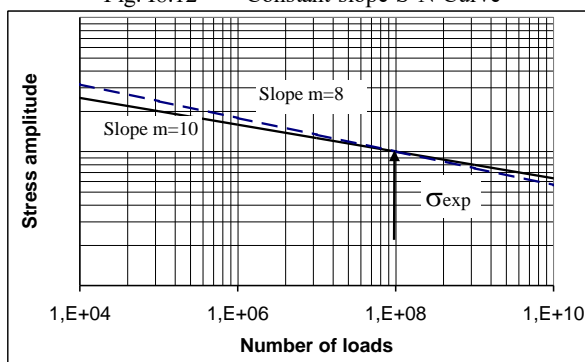

Fig. 18.11 Two-slope S-N Curve

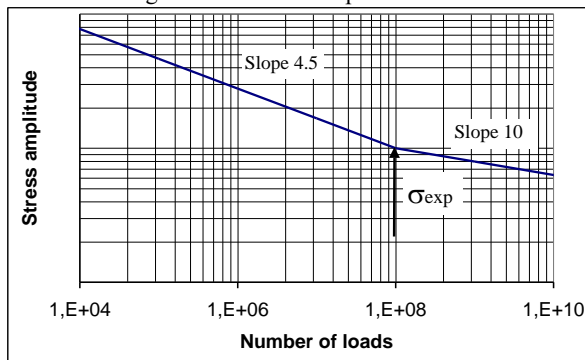

Table 18.23 The Coefficients C_1 , C_2 , C_3 and C_4

Coefficients	Open propeller	Ducted propeller
C_1	0.000747	0.000534
C_2	0.0645	0.0533
C_3	-0.0565	-0.0459
C_4	2.220	2.584

Table I8.24 Value for the G Parameter for Different m/k Ratios

m/k	G
3	6
3.5	11.6
4	24
4.5	52.3
5	120

m/k	G
5.5	287.9
6	720
6.5	1871
7	5040
7.5	14034

m/k	G
8	40320
8.5	119292
9	362880
9.5	1.133E6
10	3.629E6

m/k	G
10.5	11.899E6
11	39.917E6
11.5	136.843E6
12	479.002E6

4 Acceptability criterion for fatigue

The equivalent fatigue stress at all locations on a blade has to fulfill the following acceptability criterion:

$$\frac{\sigma_{fl}}{\sigma_{fat}} \geq 1.5$$

8.6.3 Propeller Bossing and CP Mechanism*

1 The blade bolts, the CP mechanism, the propeller boss, and the fitting of the propeller to the propeller shaft are to be designed to withstand maximum and fatigue design loads, as defined in 8.5. The safety factor is as follows.

- (1) The safety factor against yielding is to be greater than 1.3
- (2) The safety factor against fatigue is to be greater than 1.5

2 The safety factor for loads resulting from loss of a propeller blade through plastic bending as defined in 8.5.10 is to be greater than 1.0 against yielding.

8.6.4 Propulsion Shaft Line

1 The shafts and shafting components, such as the thrust and stern tube bearings, couplings, flanges and sealings, are to be designed to withstand the propeller/ice interaction axial, bending and torsion loads. The safety factor is to be at least 1.3 against yielding for extreme operational loads, 1.5 for fatigue loads and 1.0 against yielding for the blade failure load.

2 The blade failure load as defined in Section 8.5.10 is not to cause yielding in shafts and shaft components. The loading is to consist of the combined axial, bending, and torsion loads, wherever this is significant. The minimum safety factor against yielding is to be 1.0 for bending and torsional stresses.

8.6.5 Azimuthing Main Propulsors

With respect to azimuthing main propulsor, the followings are to be complied with in addition to the requirements specified in 8.6.1:

(1) Design principle

(a) Azimuthing thrusters are to be designed for thruster body/ice interaction loads. Load formulae specified in this 8.6.5 are given for estimating once in a lifetime extreme loads on the thruster body, based on the estimated ice condition and ship operational parameters. In this 8.6.5, the following load scenario types are considered:

- i) Ice block impact on the thruster body or propeller hub (See Fig. I8.13)
- ii) Thruster penetration into an ice ridge that has a thick consolidated layer (See Fig. I8.13)
- iii) Vibratory response of the thruster at blade order frequency

(b) The steering mechanism, the fitting of the unit and body of the thruster are to be designed to withstand the plastic bending of a blade without damage.

(c) The loss of a blade is to be taken into account for the propeller blade position, which causes the maximum load on the considered component.

(2) Extreme ice impact loads

(a) The thruster is to withstand the loads occurring when the design ice block defined in Table I8.14 impacts on the thruster body when the ship is sailing at a typical ice operating speed. Load cases for impact loads are given in Table I8.25. The contact geometry is estimated to be hemispherical in shape. If the actual contact geometry differs from the shape of the hemisphere, a sphere radius is to be estimated so that the growth of the contact area as a function of penetration of ice corresponds as closely as possible to the actual geometrical shape penetration.

(b) The ice impact contact load F_{ti} is to be calculated using the following formula. The related parameter values are given in

Table 18.26. The design operation speed in ice can be derived from **Table 18.27** and **Table 18.28**, or the ship in question's actual design operation speed in ice can be used. For the pulling propeller configuration, the longitudinal impact speed is used for load case T2 (See **Table 18.25**), impact on hub; and for the pushing propeller unit, the longitudinal impact speed is used for load case T1 (See **Table 18.25**), impact on thruster end cap. For the opposite direction, the impact speed for transversal impact is applied.

$$F_{ti} = C_{DMI} 34.5 R_c^{0.5} (m_{ice} v_s^2)^{0.333} \text{ (kN)}$$

where

R_c : Impacting part sphere radius (See **Fig. 18.14**)

m_{ice} : Ice block mass (kg)

v_s : Ship speed at the time of contact (m/s)

C_{DMI} : Dynamic magnification factor for impact loads. If unknown, C_{DMI} is to be taken from **Table 18.26**.

For impacts on non-hemispherical areas, such as the impact on the nozzle, the equivalent impact sphere radius R_{ceq} instead of R_c is to be used, where R_{ceq} is estimated using the equation below.

$$R_{ceq} = \sqrt{\frac{A}{\pi}} \text{ (m)}$$

where

A : The max contact area that the ice block can have. When determining A , the dimensions of the relevant part of the thruster as well as the size of the ice block need to be considered.

If the $2R_{ceq}$ is greater than the ice block thickness, R_{ceq} is set to half of the ice block thickness. This limitation is not valid for the impact on the propeller hub or thruster end cap (load case T1a and T2a). For the impact on the thruster side, the pod body diameter can be used as a basis for determining the radius. For the impact on the propeller hub, the hub diameter can be used as a basis for the radius.

(3) Extreme ice loads on thruster hull when penetrating an ice ridge

The maximum load on thruster hull when penetrating an ice ridge (F_{tr}) is to be estimated for the load cases shown in **Table 18.29**, using the following equation. The parameter values for calculations are given in **Table 18.30** and **Table 18.31**. The loads are to be applied as uniform distributed load or uniform pressure over the thruster surface. The design operation speed in ice can be derived from **Table 18.30** or **Table 18.31**. Alternatively, the actual design operation speed in ice of the ship in question can be used.

$$F_{tr} = 32 v_s^{0.66} H_r^{0.9} A_t^{0.74} \text{ (kN)}$$

where

v_s : Ship speed (m/s)

H_r : Design ridge thickness (m) (the thickness of the consolidated layer is 18% of the total ridge thickness)

A_t : Projected area of the thruster (m^2)

When calculating the contact area for thruster-ridge interaction, the loaded area in the vertical direction is limited to the ice ridge thickness, as shown in **Fig. 18.15**.

(4) The stresses on the thruster are to be calculated for the extreme once-in-a-lifetime loads described in this **8.6.5**. The nominal von Mises stresses on the thruster body are to have a safety margin of 1.3 against the yielding strength of the material. At areas of local stress concentrations, stresses are to have a safety margin of 1.0 against yielding. The slewing bearing, bolt connections and other components are to be able to maintain operability without incurring damage that requires repair when subject to the loads given in (2) and (3) multiplied by a safety factor of 1.3.

(5) The global vibratory behavior of the thruster body is to be evaluated, when considering cases where first blade order excitations are in the same frequency range with the thruster global modes of vibration, which occur when the propeller rotational speeds are in the high power range of the propulsion line. Based upon this evaluation, the following (a) or (b) is to be shown. When estimating thruster global natural frequencies in the longitudinal and transverse direction, the damping and added mass due to water are to be taken into account. In addition to this, the effect of ship attachment stiffness is to be modelled.

(a) There is either no global first blade order resonance at high operational propeller speeds (above 50% of maximum power).

(b) The structure is designed to withstand vibratory loads during resonance above 50% of maximum power.

Fig. I8.13 Examples of load scenario types

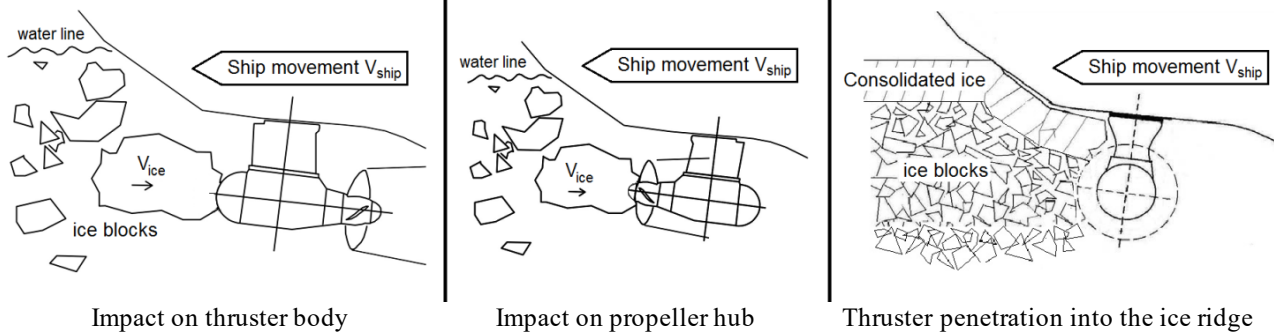
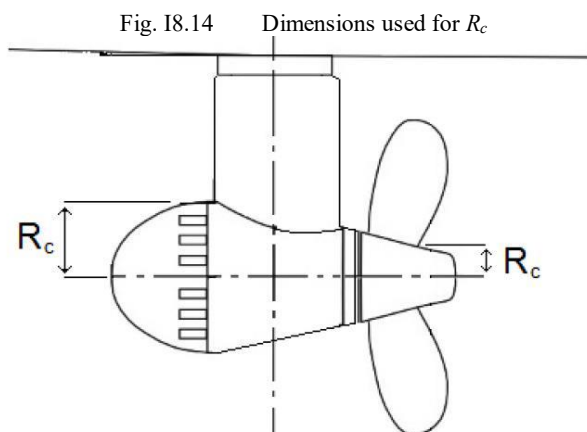

Table I8.25 Load cases for azimuthing thruster ice impact loads

	Force	Loaded area	
Load case T1a Symmetric longitudinal ice impact on thruster	F_{ti}	Uniform distributed load or uniform pressure, which are applied symmetrically on the impact area.	
Load case T1b Non-symmetric longitudinal ice impact on thruster	50% of F_{ti}	Uniform distributed load or uniform pressure, which are applied on the other half of the impact area.	
Load case T1c Non-symmetric longitudinal ice impact on nozzle	F_{ti}	Uniform distributed load or uniform pressure, which are applied on the impact area. Contact area is equal to the nozzle thickness (H_{nz}) x the contact height (H_{ice}).	
Load case T2a Symmetric longitudinal ice impact on propeller hub	F_{ti}	Uniform distributed load or uniform pressure, which are applied symmetrically on the impact area.	
Load case T2b Non-symmetric longitudinal ice impact on propeller hub	50% of F_{ti}	Uniform distributed load or uniform pressure, which are applied on the other half of the impact area.	
Load case T3a Symmetric lateral ice impact on thruster body	F_{ti}	Uniform distributed load or uniform pressure, which are applied symmetrically on the impact area.	

	Force	Loaded area	
Load case T3b Non-symmetric lateral ice impact on thruster body or nozzle	F_{ti}	Uniform distributed load or uniform pressure, which are applied on the impact area. Nozzle contact radius R to be taken from the nozzle length (L_{nz}).	

 Table I8.26 Value of H_{ice} , m_{ice} , C_{DMI}

	IA Super	IA	IB	IC
Thickness of the design ice block impacting thruster: $2/3H_{ice}$ (m)	1.17	1.0	0.8	0.67
Extreme ice block mass: m_{ice} (kg)	8670	5460	2800	1600
C_{DMI} (if not known)	1.3	1.2	1.1	1

Table I8.27 Impact speeds for aft centerline thruster

	IA Super	IA	IB	IC
Longitudinal impact in main operational direction (m/s)	6	5	5	5
Longitudinal impact in reversing direction (m/s) (pushing unit propeller hub or pulling unit cover end cap impact)	4	3	3	3
Transversal impact in bow first operation (m/s)	3	2	2	2
Transversal impact in stern first operation (double acting ship) (m/s)	4	3	3	3

Table I8.28 Impact speeds for aft wing, bow centerline and bow wing thrusters

	IA Super	IA	IB	IC
Longitudinal impact in main operational direction (<i>m/s</i>)	6	5	5	5
Longitudinal impact in reversing direction (<i>m/s</i>) (pushing unit propeller hub or pulling unit cover end cap impact)	4	3	3	3
Transversal impact (<i>m/s</i>)	4	3	3	3

Table I8.29 Load cases for azimuthing thruster ridge ice loads

	Force	Loaded area	
Load case T4a Symmetric longitudinal ridge penetration loads	F_{tr}	Uniform distributed load or uniform pressure, which are applied symmetrically on the impact area.	
Load case T4b Non-symmetric longitudinal ridge penetration loads	50% of F_{tr}	Uniform distributed load or uniform pressure, which are applied on the other half of the contact area.	
Load case T5a Symmetric lateral ridge penetration loads for ducted azimuthing unit and pushing open propeller unit	F_{tr}	Uniform distributed load or uniform pressure, which are applied symmetrically on the contact area.	
Load case T5b Non-symmetric lateral ridge penetration loads for all azimuthing units	50% of F_{tr}	Uniform distributed load or uniform pressure, which are applied on the other half of the contact area.	

Fig. I8.15 Schematic figure showing the reduction of the contact area by the maximum ridge thickness

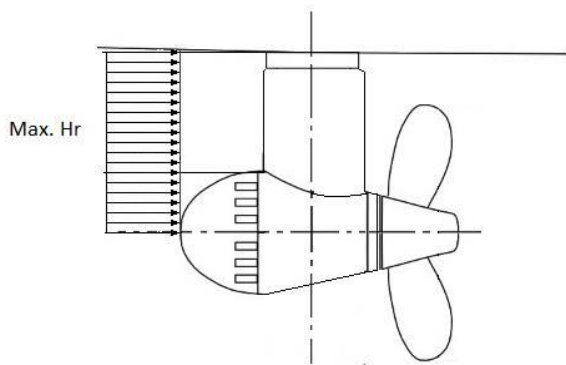

Table I8.30 Parameters for calculating maximum loads when the thruster penetrates an ice ridge (Aft thrusters, Bow first operation)

	<i>IA Super</i>	<i>IA</i>	<i>IB</i>	<i>IC</i>
Thickness of the design ridge consolidated layer (<i>m</i>)	1.5	1.5	1.2	1.0
Total thickness of the design ridge H_r (<i>m</i>)	8	8	6.5	5
Initial ridge penetration speed (longitudinal loads) (<i>m/s</i>)	4	2	2	2
Initial ridge penetration speed (transversal loads) (<i>m/s</i>)	2	1	1	1

Table I8.31 Parameters for calculating maximum loads when the thruster penetrates an ice ridge (Thruster first mode such as double acting ships)

	<i>IA Super</i>	<i>IA</i>	<i>IB</i>	<i>IC</i>
Thickness of the design ridge consolidated layer (<i>m</i>)	1.5	1.5	1.2	1.0
Total thickness of the design ridge H_r (<i>m</i>)	8	8	6.5	5
Initial ridge penetration speed (longitudinal loads) (<i>m/s</i>)	6	4	4	4
Initial ridge penetration speed (transversal loads) (<i>m/s</i>)	3	2	2	2

8.7 Alternative Design

8.7.1 Alternative Design*

As an alternative to 8.5 and 8.6, a comprehensive design study may be carried out.

8.8 Design of Propulsion Units (Ice Class *ID*)

8.8.1 General

For *ID* ice class ships, the design of the ship is to satisfy the requirements in 8.8.2, 8.8.3 and 8.8.4. However, all or part of such designs may be in accordance with the requirements in 8.6 for *IC* ice class ships instead.

8.8.2 Propeller Shafts

The diameter of propeller shafts is to be increased by 5% against the value obtained by 6.2.4, Part D.

8.8.3 Thickness of Propeller Blades

- 1 The thickness of propeller blades is to be increased by 8% against the value obtained by 7.2.1, Part D.
- 2 The thickness of the tip of propeller blades (at a radius of $0.95R$) is not to be less than the value obtained by the following formula:

$$t = 0.14(T + 57) \sqrt[3]{\frac{430}{\sigma_b}}$$

- t : Thickness of the tip of propeller blade (at a radius of $0.95R$) (mm)
 T : Thickness of the root of the propeller blade specified in 8.8.3-1 (i.e., the thickness of blade at a radius of $0.25R$ for solid propellers and the thickness of blade at a radius of $0.35R$ for controllable pitch propellers) (mm)
 σ_b : Specified tensile strength of propeller material (N/mm^2)

8.8.4 Force Fitting of Propellers

Where the propeller is force-fitted on the propeller shaft without a key, the lower limit of pull-up length is to be determined according to 7.3.1-1, Part D of the Rules, substituting F_V'' given by following formula for F_V :

$$F_V'' = F_V + \frac{9.55H}{N_0 R_0} \times 10^4 \times 0.15 \text{ (N)}$$

where

- H : Maximum continuous output of main propulsion machinery (kW)
 N_0 : Number of maximum continuous revolutions per minute divided by 100 ($rpm / 100$)
 R_0 : Radius (mm) of the propeller shaft cone part at the mid-length
 F_V : Tangential force (N) acting on contact surface specified in 7.3.1-1, Part D of the Rules.

8.9 Miscellaneous Machinery Requirements

8.9.1 Starting Arrangements

- 1 The capacity of air reservoirs is to be sufficient to provide, without reloading, not less than 12 consecutive starts of the propulsion engines if these have to be reversed for going astern, or 6 consecutive starts if such propulsion engines do not have to be reversed for going astern.
- 2 If the air reservoirs serve any other purposes than starting propulsion engines, they are to have additional capacity sufficient for such purposes.
- 3 The capacity of air compressors is to be sufficient for charging the air reservoirs from atmospheric to full pressure in one hour. In the case of *IA Super* ice class ships that require their propulsion engines to be reversed for going astern, the compressors are to be able to charge the air reservoirs in half an hour.

8.9.2 Sea Inlet and Cooling Water Systems

- 1 Cooling water systems are to be designed to secure the supply of cooling water when navigating in ice.
- 2 To satisfy -1 above, at least one cooling sea water inlet chest is to be arranged as follows. However, *ID* ice class ships may not comply with the requirements given in (2), (3) and (5):
 - (1) Sea inlets are to be situated near the centre line of ships and well aft if possible.
 - (2) As guidance for design, the volume of sea chests is to be about $1m^3$ for every $750kW$ of engine output of ships including the output of auxiliary engines necessary for the ship service.
 - (3) Sea chests are to be sufficiently high to allow ice to accumulate above inlet pipes.
 - (4) Pipes for discharging cooling water, allowing full capacity discharge, are to be connected to sea chests.
 - (5) Areas through grating holes are not to be less than 4 times inlet pipe sectional areas.
- 3 In cases where more than two sea chests are arranged, it is not necessary to satisfy the requirements given in -2(2) and (3) above. In such cases, except for *ID* ice class ships, sea chests are to be arranged for alternating the intake and discharge of cooling water as well as complying with the requirements given -2(1), (4) and (5) above.
- 4 Heating coils may be installed in the upper parts of sea chests.
- 5 Arrangements for using ballast water for cooling purposes may be useful as a reserve in terms of ballast, but cannot be accepted as a substitute for the inlet chests described above.

ANNEX 1 SPECIAL REQUIREMENTS FOR THE MATERIALS, HULL STRUCTURES, EQUIPMENT AND MACHINERY OF POLAR CLASS SHIPS

Chapter 1 GENERAL

1.1 General

1.1.1 Application

1 This Annex are to be applied to materials, constructions, equipment and machineries of polar class ships in accordance with [1.1.1-4](#) and [3.3, Part I of the Rules](#) and [I7.3.3, Part I of the Guidance](#).

2 For polar class ships, the hull form and propulsion power are to be such that the ship can operate independently and at continuous speed in a representative ice condition, as defined in [Table 1.2.2-1](#) for the corresponding Polar Class. In cases where this Annex applies to ships and ship-shaped units which are intentionally not designed to operate independently in ice, such operational intent or limitations are to be explicitly stated in the Certificate of Classification.

3 For *PC1* through *PC5* polar class ships, bows with vertical sides and bulbous bows are generally to be avoided. Bow angles are to, in general, be within the range specified in [3.1.1-1](#).

4 For *PC6* and *PC7* polar class ships designed with a bow with vertical sides or bulbous bows, operational limitations (restricted from intentional ramming, refer to [3.1.2-2](#)) in design conditions are to be stated in the Certificate of Classification.

1.2 Definitions

1.2.1 Application

The definitions of terms and symbols which appear in this Annex are to be as specified in this section and [1.2.1, Part I of the Rules](#), unless specified elsewhere.

1.2.2 Polar Classes

1 Polar Class is classified into the seven classes given in [Table 1.2.2-1](#). It is the responsibility of the Owner to determine which class in [Table 1.2.2-1](#) is most suitable for his requirement.

2 If the hull and machinery are constructed such as to comply with the requirements of different polar classes, then both the hull and machinery are to be assigned the lower of these classes in the classification certificate. Compliance of the hull or machinery with the requirements of a higher polar class is also to be indicated in the Certificate of Classification.

3 Polar class ships having powering and dimensions that allow it to undertake aggressive operations in ice-covered waters and complying with the relevant requirements of this annex are given the additional notation “*Icebreaker*” (abbreviated to *ICB*) to Polar Class notation.

Table 1.2.2-1 Polar Classes

Polar Class	Symbol	Ice description
Polar Class 1	PC1	Year-round operation in all Polar waters
Polar Class 2	PC2	Year-round operation in moderate multi-year ice condition
Polar Class 3	PC3	Year-round operation in second-year ice which may include multi-year ice inclusion
Polar Class 4	PC4	Year-round operation in thick first-year ice which may include multi-year and/or second-year ice inclusion
Polar Class 5	PC5	Year-round operation in medium first-year ice which may include multi-year and/or second-year ice inclusion
Polar Class 6	PC6	Summer/autumn operation in medium first-year ice which may include multi-year and/or second-year ice inclusions
Polar Class 7	PC7	Summer/autumn operation in thin first-year ice which may include multi-year and/or second-year ice inclusions

Notes:

Multi-year ice, second-year ice and first-year ice are based on WMO (World Meteorological Organization) Sea Ice Nomenclature.

- Multi-year ice: old ice which has survived at least two summer's melt
- Second-year ice: Sea ice which has survived only one summer's melt
- First-year ice: Sea ice of not more than one winter's growth, developing from young ice
- Thick first-year ice: first-year ice of about 120-250 *cm* in thickness and which has a high strength. Only when strong pressure is received, this ice forms an ice hill of about 150-250 *cm* in height.
- Medium first-year ice: first-year ice of about 70-120 *cm* in thickness. In the ice water regions other than Polar Regions, this kind of one-year ice is a limit stage of growth, and it is formed in the severest winter. In this kind of ice, there might be a lot of intersecting ice hills, and the height of the ice hill reaches 170 *cm*. This kind of ice melts in summer and disappears almost completely.
- Thin first-year ice: first-year ice of about 30-70 *cm* in thickness. In this kind of ice, there might be straight ice hills, and the height of the ice hill reaches 30-75 *cm* on the average. Thin first-year ice may be subdivided to the thin first-year in the first stage (30-50 *cm* in thickness) and second stages (50-70 *cm* in thickness).

1.2.3 Hull Areas

The hull areas are defined as areas reflecting the magnitude of the loads that are expected to act upon them, and divided into the following (see Fig. 1.2.3-1). If a polar class ship that installed special icebreaking stern structure and propulsion unit intended to operate astern in ice regions, the hull area of the ship is to refer to Fig. 1.2.3-2.

(1) Bow area

(a) Bow area of PC1, PC2, PC3 and PC4 polar class ships

“Bow area” is defined as the hull area which is located forward of the intersection point of the *UIWL* and the line with a waterline angle (as defined in 1.2.4) of 10 degrees at the *UIWL* (hereinafter referred to as “the aft boundary of the Bow area”), and below the line connecting the point 1.5 *m* above the *UIWL* at the aft boundary of the Bow area and the point 2.0 *m* above the *UIWL* at the stem.

(b) Bow area of PC5, PC6 and PC7 polar class ships

“Bow area” is defined as the hull area which is located forward of the intersection point of the *UIWL* and the line with a waterline angle (as defined in 1.2.4) of 10 degrees at the *UIWL*, and below the line connecting the point 1.0 *m* above the *UIWL* at the aft boundary of the Bow area and the point 2.0 *m* above the *UIWL* at the stem.

Notwithstanding the provision in (a) and (b), the aft boundary of the Bow area is not to be forward of the intersection point of the extended line of the stem frame and the baseline of the ship. In addition, the aft boundary of the Bow area need not be more than 0.45 times L_{UI} aft of the fore side of the stem at the intersection with the *UIWL*.

(2) Bow Intermediate area

- (a) Bow Intermediate area of *PC1*, *PC2*, *PC3* and *PC4* polar class ships with
 “Bow Intermediate area” is defined as the hull area which is located aft of the aft boundary of the Bow area, and forward of the vertical line $0.04L_{UI}$ aft of the point on the *UIWL* where the waterline angle is 0 degrees (hereinafter referred to as “the aft boundary of the Bow Intermediate area”), and below the line 1.5 m above the *UIWL*.
- (b) Bow Intermediate area of *PC5*, *PC6* and *PC7* polar class ships with
 “Bow Intermediate area” is defined as the hull area which is located aft of the aft boundary of the Bow area, and forward of the vertical line $0.04L_{UI}$ aft of the point on the *UIWL* where the waterline angle is 0 degrees, and below the line 1.0 m above the *UIWL*.
- (3) Stern area
- (a) Stern area of *PC1*, *PC2*, *PC3* and *PC4* polar class ships with
 “Stern area” is defined as the hull area aft of the *A.P.* to the vertical line located 70% of the distance from the *A.P.* forward the maximum breadth point at the *UIWL* (hereinafter referred to as “the fore boundary of the Stern area”), and below the line 1.5 m above the *UIWL*.
- (b) Stern area of *PC5*, *PC6* and *PC7* polar class ships
 “Stern area” is defined as the hull area aft of the *A.P.* to the vertical line located 70% of the distance from the *A.P.* forward the maximum breadth point at the *UIWL*, and below the line 1.0m above the *UIWL*.
- However, the distance from the *A.P.* to the fore boundary of the Stern area is not to be less than 0.15 times L_{UI} . If the ship is assigned the additional notation “*Icebreaker*” (abbreviated to *ICB*), the forward boundary of the stern region is to be at least $0.04L_{UI}$ forward of the section where the parallel ship side at the *UIWL* ends.
- (4) Midbody area
- (a) Midbody area of *PC1*, *PC2*, *PC3* and *PC4* polar class ships with
 “Midbody area” is defined as the hull area which is located aft of the aft boundary of the Bow Intermediate area, and forward of the fore boundary of the Stern area, and below the line 1.5 m above the *UIWL*.
- (b) Midbody area of *PC5*, *PC6* and *PC7* polar class ships
 “Midbody area” is defined as the hull area which is located aft of the aft boundary of the Bow Intermediate area, and forward of the fore boundary of the Stern area, and below the line 1.0 m above the *UIWL*.
- (5) Bottom area
 “Bottom area” is defined as the hull area which is located inside the line circumscribed by the points where the bottom shell is inclined 7 degrees from horizontal (hereinafter referred to as “the upper boundary of the Bottom area”) in the Bow Intermediate area, the Midbody area and the Stern area.
- (6) Lower area
 “Lower area” is defined as the hull area which is located upside of the upper boundary of the Bottom area, and below the line 1.5m below the *LIWL* (hereinafter referred to as “the upper boundary of the Lower area”) in the Bow Intermediate area, the Midbody area and the Stern area.
- (7) Icebelt area
 For *PC1*, *PC2*, *PC3* and *PC4* polar class ships, “Icebelt area” is defined as the hull area which is located upside of the upper boundary of the Lower area, and below the line 1.5m above the *LIWL* in the Bow Intermediate area, the Midbody area and the Stern area.
 For *PC5*, *PC6* and *PC7* polar class ships, “Icebelt area” is defined as the hull area which is located upside of the upper boundary of the Lower area, and below the line 1.0m above the *LIWL* in the Bow Intermediate area, the Midbody area and the Stern area.

Fig. 1.2.3-1 Hull Areas of Polar Class Ship

For PC1, 2, 3 & 4 $x = 1.5$ m;
 For PC5, 6, 7 $x = 1.0$ m;
 with "x" measured at aft end of bow region

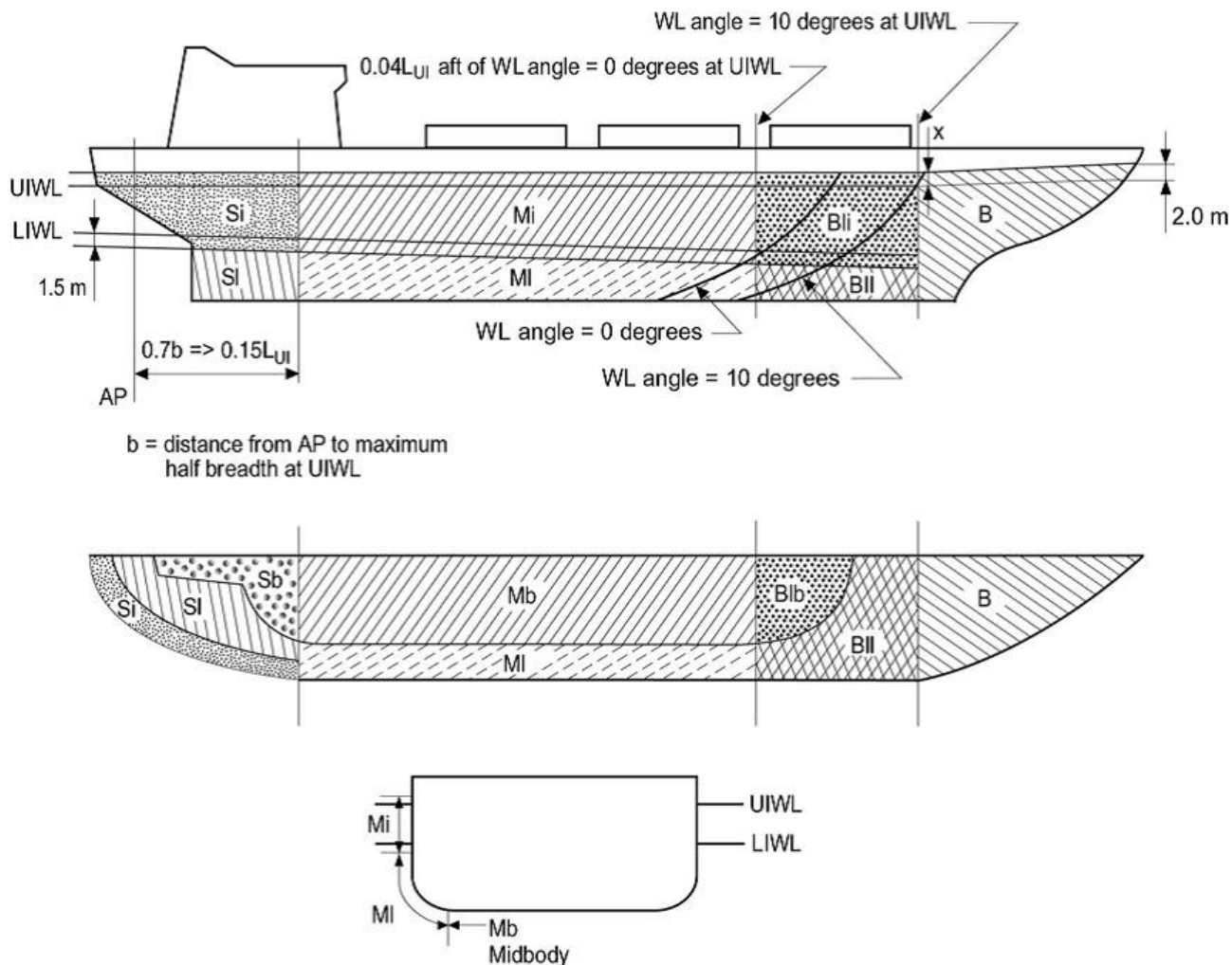

Notes:

Notation in the figure are as follows:

- B: Bow area
- BI: Bow Intermediate Icebelt area
- BII: Bow Intermediate Lower area
- Bib: Bow Intermediate Bottom area
- Mi: Midbody Icebelt area
- MI: Midbody Lower area
- Mb: Midbody Bottom area
- Si: Stern Icebelt area
- SII: Stern Lower area
- Sb: Stern Bottom area

Fig. 1.2.3-2 Hull Area for polar class ship intended to operate astern in ice regions

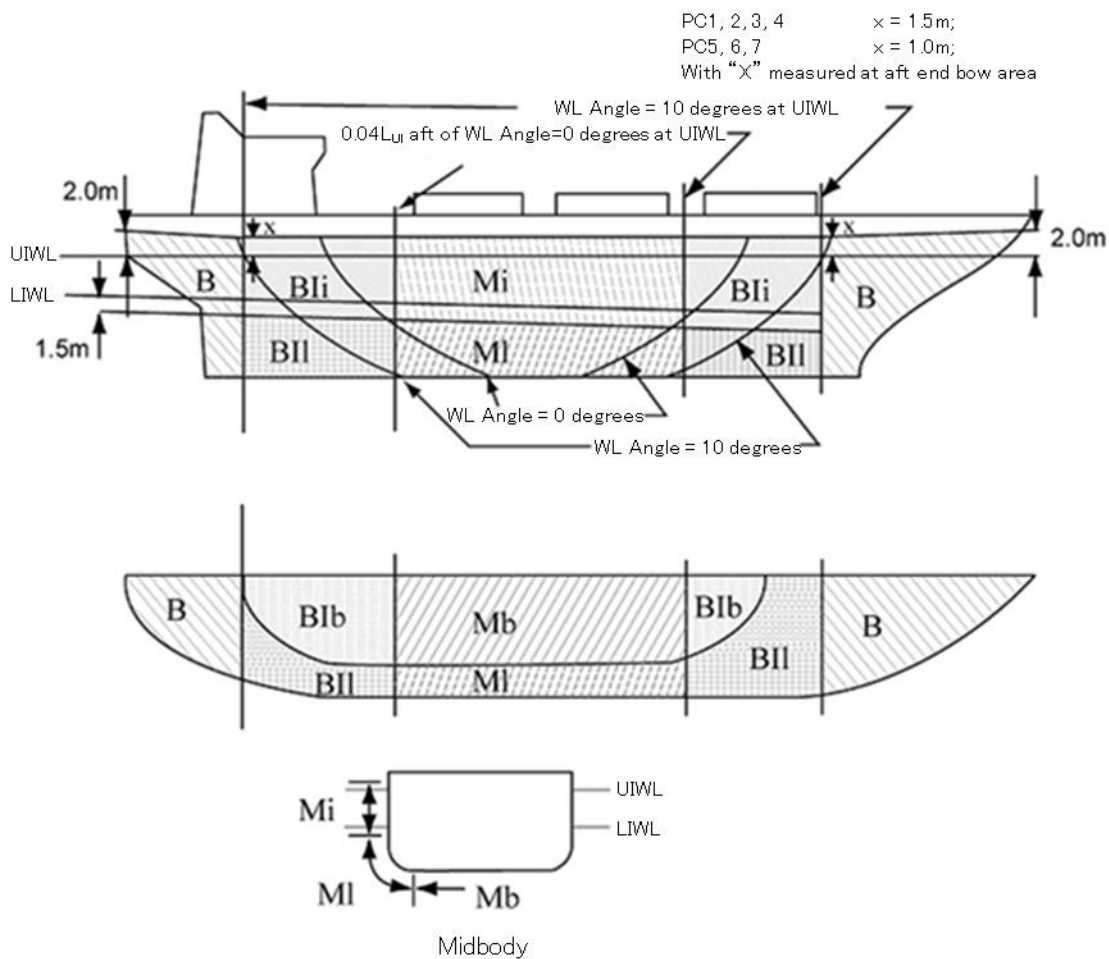

Notes:

Symbols in the figure are as follows:

B: Bow Area

Bli: Bow Intermediate Icebelt Area

BIl: Bow Intermediate Lower Area

BIb: Bow Intermediate Bottom Area

Mi: Midbody Icebelt Area

MI: Midbody Lower Area

Mb: Midbody Bottom

1.2.4 Terms

1 Waterline angle is defined as the angle between the tangential line of side shell and the line of longitudinal direction of a ship at water line. (See Fig. 1.2.4-1)

Fig. 1.2.4-1 Waterline Angle α

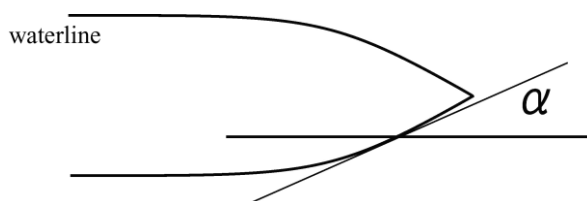

2 The length L_{UI} is the distance, in m, measured horizontally from the fore side of the stem at the intersection with the $UIWL$ to the after side of the rudder post or the centre of the rudder stock if there is no rudder post. L_{UI} is not to be less than 96 %, and need not be greater than 97 %, of the extreme length of the $UIWL$ measured horizontally from the fore side of the stem. In ships with unusual stern and bow arrangement the length L_{UI} will be specially considered.

3 The ship displacement D_{UI} is the displacement, in kt , of the ship corresponding to the $UIWL$. Where multiple waterlines are used for determining the $UIWL$, the displacement is to be determined from the waterline corresponding to the greatest displacement.

Chapter 2 MATERIALS AND WELDING

2.1 Material

2.1.1 Materials for Hull Structures

Materials such as rolled steels, steel castings, steel forgings, etc. used for hull structures are to comply with the requirements of **Chapter 3, Part K of the Rules**.

2.1.2 Material Classes and Grades*

- 1 Material classes and grades used for the hull structure are given in **Table 2.1.2-1** to **Table 2.1.2-4**.
- 2 In addition, material classes for weather and sea exposed structural members and for members attached to the weather and sea exposed shell plating of polar class ships are given in **Table 2.1.2-5**.
- 3 For polar class ships designed base on a designated design temperature, the steels used for hull structures are to comply with the requirements in **3.2.2.2, Part 1, Part C**. However, regardless of the design temperature, the steel grades are not to be of lower than the steel grade provided in **Part I of the Rules**.
- 4 The steel grade of rolled steels with a thickness of 50 mm or more and/or a minimum upper yield stress of 390 N/mm² or more is deemed appropriate by the Society.
- 5 Where stainless clad steel is used for hull structure, **Table 2.1.3-1** and **Table 2.1.3-2** are to apply according to thickness of the base metal in lieu of thickness of the plates.

Table 2.1.2-1 Material Classes for Structural Members in general

Structural Member Category	Material Class/Grade
SECONDARY: A1. Longitudinal bulkhead strakes, other than that belonging to the Primary category A2. Deck plating exposed to weather, other than that belonging to the Primary or Special category A3. Side plating	-Class I within 0.4L amidships -Grade A/AH ⁽³⁾ outside 0.4L amidships
PRIMARY: B1. Bottom plating, including keel plate B2. Strength deck plating, excluding that belonging to the Special category B3. Continuous longitudinal members above strength deck, excluding hatch coamings B4. Uppermost strake in longitudinal bulkhead B5. Vertical strake (hatch side girder) and uppermost sloped strake in top wing tank	-Class II within 0.4L amidships -Grade A/AH ⁽³⁾ outside 0.4L amidships
SPECIAL C1. Sheer strake at strength deck ⁽²⁾ C2. Stringer plate in strength deck ⁽²⁾ C3. Deck strake at longitudinal bulkhead, excluding deck plating in way of inner-skin bulkhead of double-hull ships ⁽²⁾	-Class III within 0.4L amidships -Class II outside 0.4L amidships -Class I outside 0.6L amidships
C4. Strength deck plating at outboard corners of cargo hatch openings in container carriers and other ships with similar hatch opening configuration	-Class III within 0.4L amidships -Class II outside 0.4L amidships -Class I outside 0.6L amidships -Min. Class III within cargo region
C5. Strength deck plating at corners of cargo hatch openings in bulk carriers, ore carriers, combination carriers and other ships with similar hatch opening configuration	-Class III within 0.6L amidships -Class II within rest of cargo region
C6. Bilge strake in ships with double bottom over the full breadth and length less than 150 m ⁽²⁾	-Class II within 0.6L amidships -Class I outside 0.6L amidships
C7. Bilge strake in other ships ⁽²⁾	-Class III within 0.4L amidships -Class II outside 0.4L amidships -Class I outside 0.6L amidships
C8. Longitudinal hatch coamings of length greater than 0.15L C9. End brackets and deck house transition of longitudinal cargo hatch openings	-Class III within 0.4L amidships -Class II outside 0.4L amidships -Class I outside 0.6L amidships -Not to be less than Grade D/DH ⁽⁴⁾

Notes:

- (1) Shell strakes in way of hull areas specified in 1.2.3 for plates are not to be less than Grade B/AH.
- (2) Single strakes required to be of class III within 0.4L amidships are to have breadths not less than 5L+800 mm, need not be greater than 1,800 mm, unless limited by the geometry of the ship's design.
- (3) A means KA, AH means KA32, KA36 or KA40
- (4) D means KD, DH means KD32, KD36 or KD40

Table 2.1.2-2 Minimum Material Grades for ships with length exceeding 150 m
and single strength deck

Structural Member Category	Material Grade
Longitudinal strength members of strength deck plating	Grade <i>B/AH</i> ⁽¹⁾ within 0.4 <i>L</i> amidships
Continuous longitudinal strength members above strength deck	Grade <i>B/AH</i> ⁽¹⁾ within 0.4 <i>L</i> amidships
Single side strakes for ships without inner continuous longitudinal bulkhead(s) between bottom and the strength deck	Grade <i>B/AH</i> ⁽¹⁾ within cargo region

Note:

- (1) *B* means *KB*, *AH* means *KA32*, *KA36* or *KA40*

Table 2.1.2-3 Minimum Material Grades for ships with length exceeding 250 m

Structural Member Category	Material Grade
Sheer strake at strength deck ⁽¹⁾	Grade <i>E/EH</i> ⁽²⁾ within 0.4 <i>L</i> amidships
Stringer plate in strength deck ⁽¹⁾	Grade <i>E/EH</i> ⁽²⁾ within 0.4 <i>L</i> amidships
Bilge strake ⁽¹⁾	Grade <i>D/DH</i> ⁽³⁾ within 0.4 <i>L</i> amidships

Notes:

- (1) Single strakes required to be of Grade *D/DH* or Grade *E/EH* as shown in the above table and within 0.4*L* amidships are to have breadths not less than $5L + 800$ mm, need not be greater than 1,800 mm, unless limited by the geometry of the ship's design.
- (2) *E* means *KE*, *EH* means *KE32*, *KE36* or *KE40*
- (3) *D* means *KD*, *DH* means *KD32*, *KD36* or *KD40*

 Table 2.1.2-4 Minimum Material Grades for ships of *BC-A* and *BC-B*

Structural Member Category	Material Grade
Lower bracket of ordinary side frame ⁽¹⁾⁽²⁾	Grade <i>D/DH</i> ⁽³⁾
Side shell strakes included totally or partially between the two points located to 0.125 <i>l</i> above and below the intersection of side shell and bilge hopper sloping plate or inner bottom plate ⁽²⁾	Grade <i>D/DH</i> ⁽³⁾

Notes:

- (1) The term "lower bracket" means webs of lower brackets and webs of the lower part of side frames up to the point of 0.125*l* above the intersection of side shell and bilge hopper sloping plate or inner bottom plate.
- (2) The span of the side frame, *l*, is defined as the distance between the supporting structures.
- (3) *D* means *KD*, *DH* means *KD32*, *KD36* or *KD40*

Table 2.1.2-5 Material Classes for Structural Members of Polar Class Ships

Structural Members	Material Class
Shell plating within the Bow and Bow Intermediate Icebelt hull areas (<i>B</i> , <i>B_{II}</i>)	II
All weather and sea exposed Secondary and Primary, as defined in Table 2.1.2-1 , structural members outside 0.4 <i>L_{UL}</i> amidships	I
Plating materials for stem and stern frames, rudder hone, rudder, propeller nozzle, shaft brackets, ice skeg, ice knife and other appendages subject to ice impact loads	II
All inboard framing members attached to the weather and sea-exposed plating including any contiguous inboard member within 600 mm of the plating	I
Weather-exposed plating and attached framing in cargo holds of ships which by nature of their trade have their cargo hold hatches open during cold weather operations	I
All weather and sea exposed Special, as defined in Table 2.1.2-1 , structural members within 0.2 <i>L_{UL}</i> from <i>FP</i>	II

2.1.3 Steel Grade

1 Steel grades for all plating and attached framing of hull structures and appendages situated below the level of 0.3 m below the *LIWL*, are to be obtained from **Table 2.1.3-1** based on the Material Classes for Structural members in **Table 2.1.2-1** to **Table 2.1.2-5** above, regardless of polar classes.

2 Steel grades for all weather exposed plating of hull structures and appendages situated above the level of 0.3 m below the *LIWL* are to be not less than that given in **Table 2.1.3-2** based on the Material Class for Structural Members in **Table 2.1.2-1** to **Table 2.1.2-5** above, regardless of polar class.

Table 2.1.3-1 Steel Grades for Plating and attached Framing below the Level of 0.3m below the *LIWL*

Thickness <i>t</i> (mm)	Material Class I		Material Class II		Material Class III	
	<i>MS</i>	<i>HT</i>	<i>MS</i>	<i>HT</i>	<i>MS</i>	<i>HT</i>
$t \leq 15$	<i>A</i>	<i>AH</i>	<i>A</i>	<i>AH</i>	<i>A</i>	<i>AH</i>
$15 < t \leq 20$	<i>A</i>	<i>AH</i>	<i>A</i>	<i>AH</i>	<i>B</i>	<i>AH</i>
$20 < t \leq 25$	<i>A</i>	<i>AH</i>	<i>B</i>	<i>AH</i>	<i>D</i>	<i>DH</i>
$25 < t \leq 30$	<i>A</i>	<i>AH</i>	<i>D</i>	<i>DH</i>	<i>D</i>	<i>DH</i>
$30 < t \leq 35$	<i>B</i>	<i>AH</i>	<i>D</i>	<i>DH</i>	<i>E</i>	<i>EH</i>
$35 < t \leq 40$	<i>B</i>	<i>AH</i>	<i>D</i>	<i>DH</i>	<i>E</i>	<i>EH</i>
$40 < t \leq 50$	<i>D</i>	<i>DH</i>	<i>E</i>	<i>EH</i>	<i>E</i>	<i>EH</i>

Notes:

(1) Shell strakes in way of hull areas specified in **1.2.3** for plates are not to be less than Grade *B/AH*.

(2) *A, B, D, E, AH, DH* and *EH* mean following steel grades;

A: *KA*

B: *KB*

D: *KD*

E: *KE*

AH: *KA32, KA36* or *KA40*

DH: *KD32, KD36* or *KD40*

EH: *KE32, KE36* or *KE40*

Table 2.1.3-2 Steel Grades for Weather Exposed Plating

Thickness, <i>t</i> (mm)	Material Class I				Material Class II				Material Class III					
	<i>PC1-5</i>		<i>PC6&7</i>		<i>PC1-5</i>		<i>PC6&7</i>		<i>PC1-3</i>		<i>PC4&5</i>		<i>PC6&7</i>	
	<i>MS</i>	<i>HT</i>	<i>MS</i>	<i>HT</i>	<i>MS</i>	<i>HT</i>	<i>MS</i>	<i>HT</i>	<i>MS</i>	<i>HT</i>	<i>MS</i>	<i>HT</i>	<i>MS</i>	<i>HT</i>
$t \leq 10$	<i>B</i>	<i>AH</i>	<i>B</i>	<i>AH</i>	<i>B</i>	<i>AH</i>	<i>B</i>	<i>AH</i>	<i>E</i>	<i>EH</i>	<i>E</i>	<i>EH</i>	<i>B</i>	<i>AH</i>
$10 < t \leq 15$	<i>B</i>	<i>AH</i>	<i>B</i>	<i>AH</i>	<i>D</i>	<i>DH</i>	<i>B</i>	<i>AH</i>	<i>E</i>	<i>EH</i>	<i>E</i>	<i>EH</i>	<i>D</i>	<i>DH</i>
$15 < t \leq 20$	<i>D</i>	<i>DH</i>	<i>B</i>	<i>AH</i>	<i>D</i>	<i>DH</i>	<i>B</i>	<i>AH</i>	<i>E</i>	<i>EH</i>	<i>E</i>	<i>EH</i>	<i>D</i>	<i>DH</i>
$20 < t \leq 25$	<i>D</i>	<i>DH</i>	<i>B</i>	<i>AH</i>	<i>D</i>	<i>DH</i>	<i>B</i>	<i>AH</i>	<i>E</i>	<i>EH</i>	<i>E</i>	<i>EH</i>	<i>D</i>	<i>DH</i>
$25 < t \leq 30$	<i>D</i>	<i>DH</i>	<i>B</i>	<i>AH</i>	<i>E</i>	<i>EH</i> ⁽¹⁾	<i>D</i>	<i>DH</i>	<i>E</i>	<i>EH</i>	<i>E</i>	<i>EH</i>	<i>E</i>	<i>EH</i>
$30 < t \leq 35$	<i>D</i>	<i>DH</i>	<i>B</i>	<i>AH</i>	<i>E</i>	<i>EH</i>	<i>D</i>	<i>DH</i>	<i>E</i>	<i>EH</i>	<i>E</i>	<i>EH</i>	<i>E</i>	<i>EH</i>
$35 < t \leq 40$	<i>D</i>	<i>DH</i>	<i>D</i>	<i>DH</i>	<i>E</i>	<i>EH</i>	<i>D</i>	<i>DH</i>	⁽²⁾	<i>FH</i>	<i>E</i>	<i>EH</i>	<i>E</i>	<i>EH</i>
$40 < t \leq 45$	<i>E</i>	<i>EH</i>	<i>D</i>	<i>DH</i>	<i>E</i>	<i>EH</i>	<i>D</i>	<i>DH</i>	⁽²⁾	<i>FH</i>	<i>E</i>	<i>EH</i>	<i>E</i>	<i>EH</i>
$45 < t \leq 50$	<i>E</i>	<i>EH</i>	<i>D</i>	<i>DH</i>	<i>E</i>	<i>EH</i>	<i>D</i>	<i>DH</i>	⁽²⁾	<i>FH</i>	⁽²⁾	<i>FH</i>	<i>E</i>	<i>EH</i>

Notes:

(1) Grades *D, DH* are allowed for a single strake of side shell plating not more than 1.8 m wide from 0.3 m below the lowest ice waterline.

(2) *MS* is not to be used.

(3) *B, D, E, AH, DH, EH* and *FH* mean following steel grades;

B: KB

D: KD

E: KE

AH: KA32, KA36 or KA40

DH: KD32, KD36 or KD40

EH: KE32, KE36 or KE40

FH: KF32, KF36 or KF40

2.1.4 Materials other than Rolled Steel Plate

Materials other than rolled steel plate are to be of appropriate chemical composition for the expected service temperature.

2.1.5 Materials for Machinery Parts Exposed to Sea Water

1 Materials exposed to sea water, such as propeller blades, propeller hub and cast thruster bodies are to have an elongation of not less than 15% for the *U14A* test specimen in **Part K of the Rules**.

2 Materials other than bronze and austenitic steel are to have an average impact energy value of 20 *J* at -10 °C for the *U4* test specimen in **Part K of the Rules**.

3 Materials are also to be in accordance with the requirement in **Chapter 5** and **Chapter 6, Part K of the Rules** that apply to ice class ships.

2.1.6 Materials for Machinery Parts Exposed to Sea Water Temperatures

1 Except for bronze and austenitic steel, materials exposed to sea water temperatures are to have an average impact energy value of 20 *J* at -10°C for the *U4* test specimen in **Part K of the Rules**. Materials are also to be in accordance with requirements in **Chapter 5** and **Chapter 6, Part K of the Rules** that apply to ice class ships.

2 This **2.1.6** applies to components such as but not limited to blade bolts, controllable pitch mechanisms, shaft bolts, propeller shafts and strut-pod connecting bolts.

3 This **2.1.6** does not apply to surface hardened components, such as bearings and gear teeth or sea water cooling lines (heat exchangers, pipes, valves, fittings etc.).

4 Definitions for structural boundaries exposed to sea water temperatures are the level of 0.3 *m* below the *LIWL* as specified in **2.1.3**.

2.1.7 Materials for Machinery Parts Exposed to Low Air Temperatures

1 Except for bronze and austenitic steel, materials of machinery and foundations exposed to low air temperatures are to be of steel or other ductile materials approved by the Society. The materials are to have an average impact energy value of 20 *J* obtained at 10°C below the lowest design temperature for the *U4* test specimen in **Part K of the Rules**.

2 This **2.1.7** does not apply to surface hardened components, such as bearings and gear teeth. In addition, definitions for structural boundaries exposed to low air temperatures are the level of 0.3 *m* below the *LIWL* as specified in **2.1.3**.

2.2 Welding

2.2.1 General

1 Welding is to comply with the requirements of **Part M of the Rules**.

2 All fillet welding within ice-strengthened areas are to be of the double continuous type and their sizes are to be of *F2* or more as specified in **Table 12.2.1-1, Part 1, Part C**.

3 Continuity of strength is to be ensured at all structural connections, especially at the boundary between the ice-strengthened area and other areas.

2.3 Corrosion/Abrasion Additions

2.3.1 Protection of Shell Plating

Effective protection against corrosion and ice-induced abrasion is recommended for all external surfaces of the shell plating for all polar class ships.

2.3.2 Corrosion/Abrasion Additions

The values of corrosion/abrasion additions, t_s , to be used in determining the shell plate thickness for each Polar Class are listed in [Table 2.3.2-1](#).

2.3.3 Corrosion/Abrasion addition of Internal Structures

Polar class ships are to have a minimum corrosion/abrasion addition of $t_s = 1.0 \text{ mm}$ applied to all internal structures within the ice-strengthened hull areas, including plated members adjacent to the shell, as well as stiffener webs and flanges.

Table 2.3.2-1 Corrosion/Abrasion Additions for Shell Plating

Hull Area	Additional Thickness t_s (mm)					
	With Effective Protection ⁽¹⁾			Without Effective Protection		
	PC1-3	PC4&5	PC6&7	PC1-3	PC4&5	PC6&7
Bow area, Bow Intermediate Icebelt area	3.5	2.5	2.0	7.0	5.0	4.0
Bow Intermediate Lower area, Midbody Icebelt area, Stern Icebelt area	2.5	2.0	2.0	5.0	4.0	3.0
Midbody Lower area, Stern Lower area, Bottom area	2.0	2.0	2.0	4.0	3.0	2.5

Notes:

- (1) "With Effective Protection" refers to coating the ship with paints such as ice strengthening paint that takes into account use in polar waters or equivalent measures which are deemed appropriate by the Society.
- (2) Steel renewal for ice strengthened structures is required when the gauged thickness is less than $t_{\text{net}} + 0.5 \text{ mm}$.

Chapter 3 HULL STRUCTURE

3.1 Application

3.1.1 General

1 Design ice forces calculated according to **3.3.1-1(3)** are applicable for bow forms where the buttock angle γ at the stem is positive and less than 80 degrees, and the normal frame angle β' at the centre of the foremost sub-region, as defined in **Fig. 3.3.2-1**, is greater than 10 degrees.

2 Design ice forces calculated according to **3.3.1-1(4)** are applicable for *PC6* or *PC7* polar class ships having a bow form with vertical sides. This includes bows where the normal frame angles β' at the considered sub-regions, as defined in **Fig. 3.3.2-1**, are between 0 and 10 degrees.

3 For *PC6* or *PC7* polar class ships equipped with bulbous bows, the design ice forces on the bow are to be determined according to **3.3.1-1(4)**. In addition, the design forces are not to be taken less than those given in **3.3.1-1(3)**, assuming $fa = 0.6$ and $AR = 1.3$.

4 For ships with bow forms other than those defined in **-1** to **-3** above, design forces are to be specially considered by the Society.

3.1.2 Load Scenario

1 The design ice load provided in **3.3** is based on the collision load scenario, i.e., a glancing impact on the bow and determined in consideration of the following **(1)** to **(4)**.

- (1) The design ice load is characterized by an average pressure P_{avg} uniformly distributed over a rectangular load patch of height b and width w .
- (2) Within the Bow area of all polar classes, and within the Bow Intermediate Icebelt area of *PC6* and *PC7* polar class ships, the ice load parameters are functions of the actual bow shape. To determine the ice load parameters (P_{avg} , b and w), it is required to calculate the following ice load characteristics for sub-regions of the bow area; shape coefficient fa_i , total glancing impact force F_i , line load Q_i and pressure P_i .
- (3) In other ice-strengthened areas (within Midbody and Stern, Bow Intermediate Lower and Bow Intermediate Bottom areas of all polar classes, and within the Bow Intermediate Icebelt area of *PC1*, *PC2*, *PC3*, *PC4* and *PC5* polar class ships), the ice load parameters (P_{avg} , b_{NonBow} and w_{NonBow}) are determined independently of the hull shape and based on a fixed load patch aspect ratio, $AR = 3.6$.
- (4) Ship structures that are not directly subjected to ice loads may still experience inertial loads of stowed cargo and equipment resulting from ship/ice interaction. These inertial loads, based on accelerations determined by each member society, are to be considered in the design of these structures.

2 The longitudinal strength requirements given in **3.5** are based upon a ramming scenario. Intentional ramming is not considered as a design scenario for ships which are designed with vertical or bulbous bows, see **1.1.1-4**. Hence the longitudinal strength requirements given in **3.5** are not to be applied to ships with stem angle γ stem equal to or larger than 80 degrees.

3.2 Subdivision and Stability

3.2.1 Intact Stability*

Ships are to have sufficient stability in intact conditions when subject to ice accretion. Accordingly, the following **(1)** and **(2)** are to apply:

- (1) For ships operating in areas and during periods where ice accretion is likely to occur, the following icing allowance is to be made in the stability calculations:
 - (a) 30 kg/m^2 on exposed weather decks and gangways;
 - (b) 7.5 kg/m^2 for the projected lateral area of each side of the ship above the water plane; and the projected lateral area of discontinuous surfaces of rail, sundry booms, spars (except masts) and rigging of ships having no sails and the projected lateral area of other small objects is to be computed by increasing the total projected area of continuous surfaces by 5% and the static moments of this area by 10%.

- (2) Ships operating in areas and during periods where ice accretion is likely to occur are to be:
- designed to minimize the accretion of ice; and
 - equipped with such means for removing ice as the Society may require; for example, electrical and pneumatic devices, and/or special tools such as axes or wooden clubs for removing ice from bulwarks, rails and erections.

3.2.2 Stability in Damaged Condition

Ships are to be able to withstand flooding resulting from hull penetration due to ice impact, of which the damage extent is to be in accordance with the following (1) to (3). The residual stability following ice damage is to be such that the factor s_i , as defined in 2.3.2.3-1, Part 1, Part C or 4.2.3-1, Part CS, is equal to one for all loading conditions used to calculate the attained subdivision index A in 2.3.2.1-2, Part 1, Part C or 4.2.1-2, Part CS. However, for cargo ships that comply with subdivision and damage stability regulations, the residual stability criteria of that instrument is to be met for each loading condition.

- the longitudinal extent is 0.045 times L_{UI} if centred forward of the maximum breadth on the upper ice waterline, and 0.015 times L_{UI} otherwise, and are to be assumed at any longitudinal position along the ship's length;
- the transverse penetration extent is 760 mm, measured normal to the shell over the full extent of the damage; and
- the vertical extent is the lesser of 0.2 times the upper ice waterline draught or the longitudinal extent, and is to be assumed at any vertical position between the keel and 1.2 times the upper ice waterline draught.

3.3 Design Ice Load

3.3.1 Glancing Impact Load Characteristics

1 Bow area

- In the Bow area, the force F , line load Q , pressure P and load patch aspect ratio AR associated with the glancing impact load scenario are functions of the hull angles measured at the $UIWL$. The influence of the hull angles is captured through calculation of a bow shape coefficient f_a . The hull angles are defined in Fig. 3.3.2-1.
- The waterline length of the bow region is generally to be divided into 4 sub-regions of equal length. The force F , line load Q , pressure P and load patch aspect ratio AR are to be calculated with respect to the mid-length position of each sub-region (each maximum of F , Q and P is to be used in the calculation of the ice load parameters P_{avg} , b and w).
- The Bow area load characteristics for bow forms defined in 3.1.1-1 are determined as follows:
 - Shape coefficient f_{a_i} is to be taken as the minimum value obtained from the following two formulas. However, when the shape coefficient f_{a_i} is 0.6 or more, it is taken to be 0.6.

$$f_{a_{i,1}} = \left\{ 0.097 - 0.68 \left(\frac{x}{L_{UI}} - 0.15 \right)^2 \right\} \frac{\alpha_i}{\sqrt{\beta'_i}}$$

$$f_{a_{i,2}} = \frac{1.2CF_F}{\sin(\beta'_i)CF_C \left(\frac{\Delta_{UI}}{1000} \right)^{0.64}}$$

- Force F is to be obtained from the following formula.

$$F_i = f_{a_i}CF_C \left(\frac{\Delta_{UI}}{1000} \right)^{0.64} \times 1000 \text{ (kN)}$$

- Load patch aspect ratio AR_i is to be obtained from the following formula, however, when load patch aspect ratio AR_i is less than 1.3, it is taken to be 1.3.

$$AR_i = 7.46 \sin(\beta'_i)$$

- Line load Q is to be obtained from the following formula.

$$Q_i = \left(\frac{F_i}{1000} \right)^{0.61} \frac{CF_D}{AR_i^{0.35}} \times 1000 \text{ (kN/m)}$$

- Pressure P is to be obtained from the following formula:

$$P_i = \left(\frac{F_i}{1000} \right)^{0.22} CF_D^2 AR_i^{0.3} \times 1000 \text{ (kN/m}^2\text{)}$$

where

i : sub-region considered

L_{UI} : ship length (m) as defined in 1.2.4-2

x : distance (m) from the fore side of the stem at the intersection with the $UIWL$ to station under consideration

- α : waterline angle (*deg*), see [Fig. 3.3.2-1](#)
 β' : normal frame angle (*deg*), see [Fig. 3.3.2-1](#)
 Δ_{UI} : ship displacement (*t*) as defined in [1.2.4-3](#), not to be taken as less than 5,000 *t*
 CF_C : Crushing failure Class Factor from [Table 3.3.1-1](#)
 CF_F : Flexural failure Class Factor from [Table 3.3.1-1](#)
 CF_D : Load patch dimensions Class Factor from [Table 3.3.1-1](#)

(4) The Bow area load characteristics for bow forms defined in [3.1.1-2](#) are determined as follows:

(a) Shape coefficient, $f a_i$, is to be taken as

$$f a_i = \frac{\alpha_i}{30}$$

(b) Force, F_i :

$$F_i = f a_i C F_{CV} \left(\frac{\Delta_{UI}}{1000} \right)^{0.64} \times 1000 \text{ (kN)}$$

(c) Line load, Q_i :

$$Q_i = \left(\frac{F_i}{1000} \right)^{0.22} C F_{QV} \times 1000 \text{ (kN/m)}$$

(d) Pressure, P_i :

$$P_i = \left(\frac{F_i}{1000} \right)^{0.56} C F_{PV} \times 1000 \text{ (kN/m}^2\text{)}$$

where

- i : sub-region considered
 α : waterline angle (*deg*), see [Fig. 3.3.2-1](#)
 Δ_{UI} : ship displacement (*t*) as defined in [1.2.4-3](#), not to be taken as less than 5,000 *t*
 CF_{CV} : Crushing failure Class Factor from [Table 3.3.1-2](#)
 CF_{QV} : Line load Class Factor from [Table 3.3.1-2](#)
 CF_{PV} : Pressure Class Factor from [Table 3.3.1-2](#)

Fig. 3.3.2-1 Definition of Hull Angles

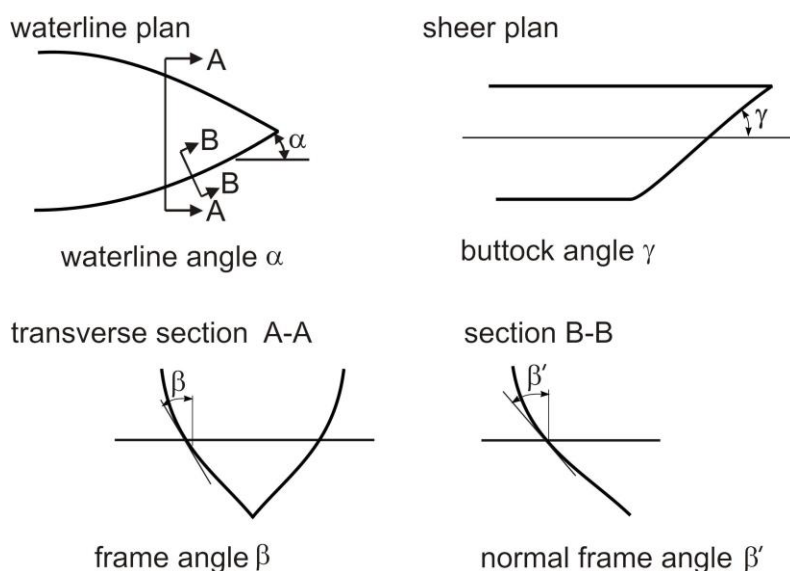

Notes :

- β' : normal frame angle (*deg*) at the *UIWL*
 α : upper ice waterline angle (*deg*)
 γ : buttock angle (*deg*) at the *UIWL* (angle of buttock line measured from horizontal)
 $\tan(\beta) = \tan(\alpha)/\tan(\gamma)$
 $\tan(\beta') = \tan(\beta) \cos(\alpha)$

Table 3.3.1-1 Class Factors

Polar Class	Crushing failure Class Factor (CF_C)	Flexural failure Class Factor (CF_F)	Load patch dimensions Class Factor (CF_D)	Displacement Class Factor (CF_{DIS})	Longitudinal strength Class Factor (CF_L)
PC1	17.69	68.60	2.01	250	7.46
PC2	9.89	46.80	1.75	210	5.46
PC3	6.06	21.17	1.53	180	4.17
PC4	4.50	13.48	1.42	130	3.15
PC5	3.10	9.00	1.31	70	2.50
PC6	2.40	5.49	1.17	40	2.37
PC7	1.80	4.06	1.11	22	1.81

Table 3.3.1-2 Class Factors

Polar Class	Crushing failure Class Factor (CF_{CV})	Line load Class Factor (CF_{QV})	Pressure Class Factor (CF_{PV})
PC6	3.43	2.82	0.65
PC7	2.60	2.33	0.65

2 Hull Areas other than the Bow

(1) In the hull areas other than the bow, the force F_{NonBow} and line load Q_{NonBow} used in the determination of the load patch dimensions (b_{NonBow} , w_{NonBow}) and design pressure P_{avg} are determined as follows:

(a) Force, F_{NonBow}

$$F_{NonBow} = 0.36CF_C DF \times 1000 \text{ (kN)}$$

(b) Line load Q_{NonBow}

$$Q_{NonBow} = 0.639 \left(\frac{F_{NonBow}}{1000} \right)^{0.61} CF_D \times 1000 \text{ (kN/m)}$$

where

CF_C : Crushing failure Class Factor from [Table 3.3.1-1](#)

DF : ship displacement factor, obtained from the following formula.

$$DF = \left(\frac{\Delta_{UI}}{1000} \right)^{0.64} \text{ if } \frac{\Delta_{UI}}{1000} \leq CF_{DIS}$$

$$DF = CF_{DIS}^{0.64} + 0.10 \left(\frac{\Delta_{UI}}{1000} - CF_{DIS} \right) \text{ if } \frac{\Delta_{UI}}{1000} > CF_{DIS}$$

where

Δ_{UI} : ship displacement (t) as defined in [1.2.4-3](#), not to be taken as less than 10,000 t

CF_{DIS} : Displacement Class Factor from [Table 3.3.1-1](#)

CF_D : Load patch dimensions Class Factor from [Table 3.3.1-1](#)

3.3.2 Design Load Patch

1 In the Bow area, and the Bow Intermediate Icebelt area for PC6 and PC7 polar class ships, the design load patch has dimensions of width, w_{Bow} , and height, b_{Bow} , defined as follows:

$$w_{Bow} = F_{Bow} / Q_{Bow} \text{ (m)}$$

$$b_{Bow} = Q_{Bow} / P_{Bow} \text{ (m)}$$

where

F_{Bow} : maximum force F_i (kN) in the Bow area

Q_{Bow} : maximum line load Q_i (kN/m) in the Bow area

P_{Bow} : maximum pressure P_i (kN/m²) in the Bow area

2 In hull areas other than those covered by -1 above, the design load patch has dimensions of width, w_{NonBow} , and height, b_{NonBow} ,

defined as follows:

$$w_{NonBow} = F_{NonBow} / Q_{NonBow} \quad (m)$$

$$b_{NonBow} = w_{NonBow} / 3.6 \quad (m)$$

where

F_{NonBow} : force (kN) as defined in 3.3.1-2(1)(a)

Q_{NonBow} : line load (kN/m) as defined in 3.3.1-2(1)(b)

3.3.3 Average Pressure

The average pressure, P_{avg} , within a design load patch is determined as follows:

$$P_{avg} = F / (b w) \quad (kN/m^2)$$

where

$F = F_{Bow}$ or F_{NonBow} as appropriate for the hull area under consideration (kN)

$b = b_{Bow}$ or b_{NonBow} as appropriate for the hull area under consideration (m)

$w = w_{Bow}$ or w_{NonBow} as appropriate for the hull area under consideration (m)

3.3.4 Peak Pressure

Areas of higher, concentrated pressure exist within the load patch. In general, smaller areas have higher local pressures. Accordingly, the peak pressure factors listed in [Table 3.3.4-1](#) are used to account for the pressure concentration on localized structural members.

Table 3.3.4-1 Peak Pressure Factors

Structural member		Peak Pressure Factor (PPF_i)
Plating	Transversely framed	$PPF_p = (1.8 - s)$, not to be less than 1.2
	Longitudinally framed	$PPF_p = (2.2 - 1.2s)$, not to be less than 1.5
Frames in transverse framing systems	With load distributing stringers	$PPF_t = (1.6 - s)$, not to be less than 1.0
	With no load distributing stringers	$PPF_t = (1.8 - s)$, not to be less than 1.2
Frames in bottom structures		$PPF_s = 1.0$
Load carrying stringers		$PPF_s = 1.0$, if $S_w \geq 0.5w$ $PPF_s = 2.0 - 2.0S_w / w$, if $S_w < 0.5w$
Side and Bottom longitudinals		
Web frames		
where	s = frame or longitudinal (m) S_w = web frame spacing (m) w = ice load patch width (m)	

3.3.5 Hull Area Factors

1 Associated with each hull area is an Area Factor that reflects the relative magnitude of the load expected in that area. The Area Factor AF for each hull area is listed in [Table 3.3.5-1](#). However, for ships assigned the additional notation “Icebreaker” (abbreviated to *ICB*), the Area Factor AF for each hull area is listed in [Table 3.3.5-2](#) instead of [Table 3.3.5-1](#).

2 In the event that a structural member spans across the boundary of a hull area, the largest hull area factor is to be used in the scantling determination of the member.

3 Due to their increased manoeuvrability, ships having propulsion arrangements with azimuthing thruster(s) or “podded” propellers are to have specially considered the Stern Icebelt S_i and the Stern Lower S_l hull area factors.

Table 3.3.5-1 Hull Area Factors AF

Hull Area		Area	Polar Class						
			$PC1$	$PC2$	$PC3$	$PC4$	$PC5$	$PC6$	$PC7$
Bow (B)	All	B	1.00	1.00	1.00	1.00	1.00	1.00	1.00
Bow Intermediate (BI)	Icebelt	BI_i	0.90	0.85	0.85	0.80	0.80	1.00*	1.00*
	Lower	BI_l	0.70	0.65	0.65	0.60	0.55	0.55	0.50
	Bottom	BI_b	0.55	0.50	0.45	0.40	0.35	0.30	0.25
Midbody (M)	Icebelt	M_i	0.70	0.65	0.55	0.55	0.50	0.45	0.45
	Lower	M_l	0.50	0.45	0.40	0.35	0.30	0.25	0.25
	Bottom	M_b	0.30	0.30	0.25	**	**	**	**
Stern (S)	Icebelt	S_i	0.75	0.70	0.65	0.60	0.50	0.40	0.35
	Lower	S_l	0.45	0.40	0.35	0.30	0.25	0.25	0.25
	Bottom	S_b	0.35	0.30	0.30	0.25	0.15	**	**

Notes :

* See 3.1.2-1(2)

** Indicates that strengthening for ice loads is not necessary.

 Table 3.3.5-2 Hull Area Factors AF for ships with additional notation “Icebreaker”
(abbreviated to ICB)

Hull Area		Area	Polar Class						
			$PC1$	$PC2$	$PC3$	$PC4$	$PC5$	$PC6$	$PC7$
Bow (B)	All	B	1.00	1.00	1.00	1.00	1.00	1.00	1.00
Bow Intermediate (BI)	Icebelt	BI_i	0.90	0.85	0.85	0.85	0.85	1.00	1.00
	Lower	BI_l	0.70	0.65	0.65	0.65	0.65	0.65	0.65
	Bottom	BI_b	0.55	0.50	0.45	0.45	0.45	0.45	0.45
Midbody (M)	Icebelt	M_i	0.70	0.65	0.55	0.55	0.55	0.55	0.55
	Lower	M_l	0.50	0.45	0.40	0.40	0.40	0.40	0.40
	Bottom	M_b	0.30	0.30	0.25	0.25	0.25	0.25	0.25
Stern (S)	Icebelt	S_i	0.95	0.90	0.80	0.80	0.80	0.80	0.80
	Lower	S_l	0.55	0.50	0.45	0.45	0.45	0.45	0.45
	Bottom	S_b	0.35	0.30	0.30	0.30	0.30	0.30	0.30

3.4 Local Strength

3.4.1 Shell Plate Requirements

1 The required minimum shell plate thickness, t , is given by:

$$t = t_{net} + t_s \text{ (mm)}$$

where

t_{net} : plate thickness (mm) required to resist ice loads according to -2

t_s : corrosion and abrasion allowance (mm) according to 2.3.2

2 The thickness of shell plating required to resist the design ice load, t_{net} , depends on the orientation of the framing.

(1) In the case of transversely-framed plating ($\Omega \geq 70$ deg):

$$t_{net} = 500s \times \sqrt{\frac{AF \times PPF_P \left(\frac{P_{avg}}{1000} \right)}{\sigma_y}} \frac{1}{1 + \frac{s}{2b}} \text{ (mm)}$$

(2) In the case of longitudinally-framed plating ($\Omega \leq 20 \text{ deg}$):

$$t_{net} = 500s \times \sqrt{\frac{AF \times PPF_p \left(\frac{P_{avg}}{1000} \right)}{\sigma_y}} \frac{1}{1 + \frac{s}{2l}} \text{ (mm), if } b \geq s$$

$$t_{net} = 500s \times \sqrt{\frac{AF \times PPF_p \left(\frac{P_{avg}}{1000} \right)}{\sigma_y}} \frac{1}{\sqrt{s - \left(\frac{b}{s} \right)^2}} \frac{1}{1 + \frac{s}{2l}} \text{ (mm), if } b < s$$

where

Ω : smallest angle (*deg*) between the chord of the waterline and the line of the first level framing as illustrated in **Fig. 3.4.1-1**

s : transverse frame spacing (*m*) in transversely-framed ships or longitudinal frame spacing (*m*) in longitudinally-framed ships

AF : Hull Area Factor from **Table 3.3.5-1** or **Table 3.3.5-2**

PPF_p : Peak Pressure Factor from **Table 3.3.4-1**

P_{avg} : average patch pressure (*kN/m²*) according to **3.3.3**

σ_y : minimum upper yield stress of the material (*N/mm²*)

b : height (*m*) of design load patch, where $b \leq (l - s/4)$ in the case of transversely-framed plating

l : distance (*m*) between frame supports, i.e. equal to the frame span as given in **3.4.2-5**, but not reduced for any fitted end brackets. When a load-distributing stringer is fitted, the length l need not be taken larger than the distance from the stringer to the most distant frame support.

(3) In the case of obliquely-framed plating ($70 \text{ deg} > \Omega > 20 \text{ deg}$), linear interpolation is to be used.

Fig. 3.4.1-1 Shell Framing Angle Ω

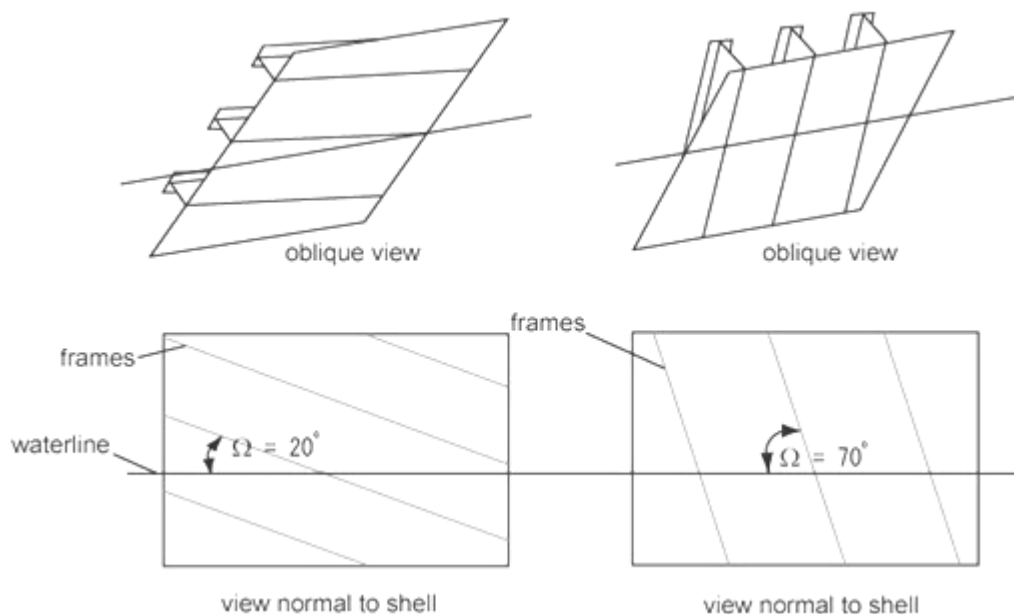

3.4.2 Framing - General

1 Framing members of polar class ships are to be designed to withstand the ice loads defined in **3.3**.

2 The term “framing member” refers to transverse and longitudinal local frames, load-carrying stringers and web frames in the areas of the hull exposed to ice pressure, see **Fig. 1.2.3-1** and **Fig. 1.2.3-2**. Where load-distributing stringers have been fitted, the arrangement and scantlings of these are to be as deemed appropriate by the Society.

3 Fixity can be assumed where framing members are either continuous through the support or attached to a supporting section with a connection bracket. In other cases, simple support is to be assumed unless the connection can be demonstrated to provide

significant rotational restraint. Fixity is to be ensured at the support of any framing which terminates within an ice-strengthened area.

4 The details of framing member intersection with other framing members, including plated structures, as well as the details for securing the ends of framing members at supporting sections, are to be in accordance with the relevant requirements of other Parts.

5 The design effective span of a framing member is to be determined on the basis of its moulded length. If brackets are fitted, the design effective span may be reduced as deemed appropriate by the Society. Brackets are to be configured to ensure stability in the elastic and post-yield response regions.

6 When calculating the section modulus and shear area of a framing member, net thicknesses of the web, flange (if fitted) and attached shell plating are to be used. The shear area of a framing member may include that material contained over the full depth of the member, i.e. web area including portion of flange, if fitted, but excluding attached shell plating.

7 The actual net effective shear area, A_w , of a transverse or longitudinal local frame is given by:

$$A_w = \frac{ht_{wn}\sin\varphi_w}{100} \text{ (cm}^2\text{)}$$

where

h : height of stiffener (mm), see [Fig. 3.4.2-1](#)

t_{wn} : net web thickness (mm), $t_{wn} = t_w - t_c$

t_w : as built web thickness (mm), see [Fig. 3.4.2-1](#)

t_c : corrosion deduction (mm) to be subtracted from the web and flange thickness (as specified by other Parts, but not less than t_s as required by [2.3.3](#)).

φ_w : smallest angle (deg) between shell plate and stiffener web, measured at the mid-span of the stiffener, see [Fig. 3.4.2-1](#). The angle φ_w may be taken as 90 degrees provided the smallest angle is not less than 75 degrees.

8 The actual net effective plastic section modulus of a transverse or longitudinal local frame is given by following (1) or (2).

(1) When the cross-sectional area of the attached plate flange exceeds the cross-sectional area of the local frame, the actual net effective plastic section modulus, Z_p , is given by:

$$Z_p = \frac{A_{pn}t_{pn}}{20} + \frac{h_w^2 t_{wn} \sin\varphi_w}{2000} + \frac{A_{fn}(h_{fc} \sin\varphi_w - b_w \cos\varphi_w)}{10} \text{ (cm}^3\text{)}$$

where

h , t_{wn} , t_c and φ_w : as given in -7 above

A_{pn} : net cross-sectional area (cm^2) of the local frame

t_{pn} : fitted net shell plate thickness (mm) (is to comply with t_{net} as required by [3.4.1-2](#))

h_w : height (mm) of local frame web, see [Fig. 3.4.2-1](#)

A_{fn} : net cross-sectional area (cm^2) of local frame flange

h_{fc} : height (mm) of local frame measured to centre of the flange area, see [Fig. 3.4.2-1](#)

b_w : distance (mm) from mid thickness plane of local frame web to the centre of the flange area, see [Fig. 3.4.2-1](#)

1

(2) When the cross-sectional area of the local frame exceeds the cross-sectional area of the attached plate flange, the plastic neutral axis is located a distance z_{na} above the attached shell plate, given by:

$$Z_{na} = \frac{100A_{fn} + h_w t_{wn} - 1000 t_{pn} s}{2t_{wn}} \text{ (mm)}$$

where

s : frame spacing (m)

The net effective plastic section modulus, Z_p , is given by:

$$Z_p = t_{pn} s \left(z_{na} + \frac{t_{pn}}{2} \right) \sin\varphi_w + \left(\frac{\left((h_w - z_{na})^2 + z_{na}^2 \right) t_{wn} \sin\varphi_w}{2000} + \frac{A_{fn} \left((h_{fc} - z_{na}) \sin\varphi_w - b_w \cos\varphi_w \right)}{10} \right) \text{ (cm}^3\text{)}$$

9 In the case of oblique framing arrangement ($70 \text{ deg} > \Omega > 20 \text{ deg}$, where Ω is defined as given in [3.4.1](#)), linear interpolation is to be used.

Fig. 3.4.2-1 Stiffener Geometry

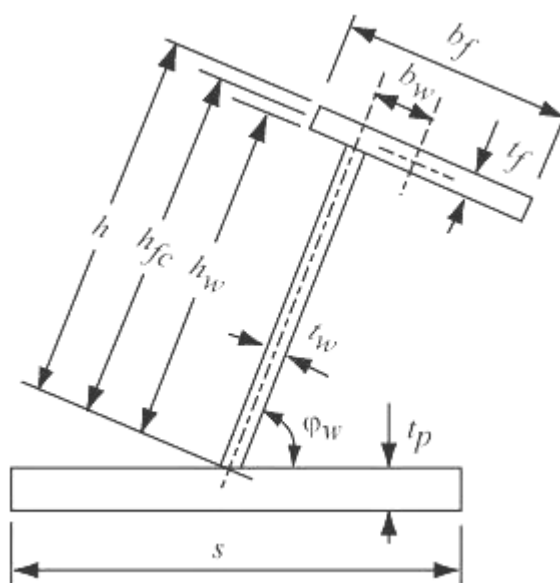

3.4.3 Framing - Local Frames in Bottom Structures and Transverse Local Frames in Side Structures

1 The local frames in bottom structures (i.e. hull areas Blb, Mb and Sb) and transverse local frames in side structures are to be dimensioned such that the combined effects of shear and bending do not exceed the plastic strength of the member. The plastic strength is defined by the magnitude of mid-span load that causes the development of a plastic collapse mechanism. For bottom structure the patch load shall be applied with the dimension, b , parallel with the frame direction.

2 The actual net effective shear area of the frame, A_w , as defined in 3.4.2-7 is to be not less than A_t determined as follows:

$$A_t = \frac{100^2 \times 0.5LLsAF \times PPF \frac{P_{avg}}{1000}}{0.577\sigma_y} \text{ (cm}^2\text{)}$$

where

LL : length of loaded portion of span (m), taken equal to lesser of a and b

a : local frame span as defined in 3.4.2-5 (m)

b : height (m) of design ice load patch as defined in 3.3.2-1 or 3.3.2-2

s : spacing of local frame (m)

AF : Hull Area Factor from Table 3.3.5-1 or Table 3.3.5-2

PPF : Peak Pressure Factor, PPF_t or PPF_s as appropriate from Table 3.3.4-1

P_{avg} : Average pressure (kN/m^2) within load patch as defined in 3.3.3

σ_y : Minimum upper yield stress of the material (N/mm^2)

3 The actual net effective plastic section modulus of the plate/stiffener combination Z_p as defined in 3.4.2-8 is to be not less than Z_{pt} determined as follows:

$$Z_{pt} = \frac{100^3 \times LL \times YsAF \times PPF \frac{P_{avg}}{1000} aA_1}{4\sigma_y} \text{ (cm}^3\text{)}$$

where

AF , PPF_t , P_{avg} , LL , b , s , a and σ_y are as given in 3.4.3-2.

$Y = 1 - 0.5(LL/a)$

A_1 : taken equal to the greater of following (a) and (b)

(a) When ice load acting at the mid-span of the local frame

$$A_1 = \frac{1}{1 + \frac{j}{2} + \frac{k_w j (\sqrt{1 - a_1^2} - 1)}{2}}$$

(b) When ice load acting near a support

$$A_1 = \frac{1 - \frac{1}{2a_1 Y}}{0.275 + 1.44k_z^{0.7}}$$

$j = 1$ for a local frame with one simple support outside the ice-strengthened areas

$j = 2$ for a local frame without any simple supports

$$a_l = A_l / A_w$$

A_l : Minimum shear area (cm^2) of the local frame as given in [3.4.3-2](#)

A_w : Effective net shear area (cm^2) of the local frame (calculated according to [3.4.2-7](#))

$k_w = 1 / (1 + 2A_{fn} / A_w)$ with A_{fn} as given in [3.4.2-8](#)

k_z : Section modulus ratio

$$k_z = z_p / Z_p \text{ in general}$$

$k_z = 0.0$ when the frame is arranged with end bracket

z_p : Sum of individual plastic section modulus (cm^3) of flange and shell plate as fitted

$$z_p = (b_f t_{fn}^2 / 4 + b_{eff} t_{pn}^2 / 4) / 1000$$

b_f : Flange breadth (mm), see [Fig. 3.4.2-1](#)

t_{fn} : net flange thickness (mm)

$$t_{fn} = t_f - t_c \text{ (} t_c \text{ as given in } [3.4.2-7](#)\text{)}$$

t_f : As-built flange thickness (mm), see [Fig. 3.4.2-1](#)

t_{pn} : The fitted net shell plate thickness (mm), not to be less than t_{net} as given in [3.4.1](#).

b_{eff} : Effective width (mm) of shell plate flange

$$b_{eff} = 500 s$$

Z_p : Net effective plastic section modulus (cm^3) of the local frame (calculated according to [3.4.2-8](#))

3.4.4 Framing - Longitudinal Local Frames in Side Structures

1 Longitudinal local frames in side structures are to be dimensioned such that the combined effects of shear and bending do not exceed the plastic strength of the member. The plastic strength is defined by the magnitude of mid-span load that causes the development of a plastic collapse mechanism.

2 The actual net effective shear area of the frame, A_w , as defined in [3.4.2-7](#) is to be not less than A_L determined as follows:

$$A_L = \frac{100^2 \left(AF \times PPF_s \frac{P_{avg}}{1000} \right) \times 0.5 b_1 a}{0.577 \varphi_y} \text{ (} cm^2 \text{)}$$

where

AF : Hull Area Factor from [Table 3.3.5-1](#) or [Table 3.3.5-2](#)

PPF_s : Peak Pressure Factor from [Table 3.3.4-1](#)

P_{avg} : Average pressure (kN/m^2) within load patch as defined in [3.3.3](#)

$$b_1 = k_o b_2 \text{ (} m \text{)}$$

$$k_o = 1 - 0.3 / b'$$

$$b' = b / s$$

b : Height (m) of design ice load patch as defined in [3.3.2-1](#) or [3.3.2-2](#)

s : Spacing (m) of longitudinal frames

b_2 : as given by

$$b_2 = b (1 - 0.25 b') \text{ (} m \text{)}, \text{ if } b' < 2$$

$$b_2 = s \text{ (} m \text{)}, \text{ if } b' \geq 2$$

a : Effective span (m) of longitudinal local frame as given in [3.4.2-5](#)

σ_y : Minimum upper yield stress of the material (N/mm^2)

3 The actual net effective plastic section modulus of the plate/stiffener combination Z_p as defined in [3.4.2-8](#) is to be not less than Z_{pL} determined as follows:

$$Z_{pL} = \frac{100^3 \left(AF \times PPF_s \frac{P_{avg}}{1000} \right) b_1 a^2 A_4}{8 \sigma_y} \text{ (} cm^3 \text{)}$$

where

AF , PPF_s , P_{avg} , b_l , a and σ_y are as given in 3.4.4-2.

$$A_4 = \frac{1}{2 + k_{wl}(\sqrt{1 - a_4^2} - 1)}$$

$$a_4 = A_L / A_w$$

A_L : Minimum shear area (cm^2) for longitudinal as given in 3.4.4-2

A_w : Net effective shear area (cm^2) of longitudinal (calculated according to 3.4.2-7)

$k_{wl} = 1 / (1 + 2 A_{fl} / A_w)$ with A_{fl} as given in 3.4.2-8

3.4.5 Framing - Web Frame and Load Carrying Stringers

1 Web frames and load-carrying stringers are to be designed to withstand the ice load patch as defined in 3.3. The load patch is to be applied at locations where the capacity of these members under the combined effects of bending and shear is minimised.

2 Web frames and load-carrying stringers are to be dimensioned such that the combined effects of shear and bending do not exceed the plastic strength of the structural members. Where the structural configuration is such that members do not form part of a grillage system, the appropriate peak pressure factor PPF from Table 3.3.4-1 is to be used, and the requirements specified in 3.4.2 to 3.4.4 are to be applied to the members.

3 Special attention is to be paid to the shear capacity in way of lightening holes and cut-outs in way of intersecting members.

4 For determination of scantlings of load carrying stringers, web frames supporting local frames, or web frames supporting load carrying stringers forming part of a structural grillage system, appropriate methods as outlined in 3.4.12 are normally to be used.

3.4.6 Framing - Structural Stability

1 To prevent local buckling in the web, the ratio of web height h_w to net web thickness t_{wn} of any framing member is not to exceed:

$$\text{For flat bar sections: } \frac{h_w}{t_{wn}} \leq \frac{282}{\sqrt{\sigma_y}}$$

$$\text{For bulb, tee and angle sections: } \frac{h_w}{t_{wn}} \leq \frac{805}{\sqrt{\sigma_y}}$$

where

h_w : web height (mm)

t_{wn} : net web thickness (mm)

σ_y : minimum upper yield stress of the material (N/mm^2)

2 Framing members for which it is not practicable to meet the requirements of 3.4.6-1 (e.g. load carrying stringers or deep web frames) are required to have their webs effectively stiffened. The scantlings of the web stiffeners are to ensure the structural stability of the framing member. The minimum net web thickness for these framing members is not to be less than of the maximum value obtained from following (a) and (b):

$$(a) \quad t_{wn} = 2.63 \times 10^{-3} \times c_1 \sqrt{\frac{\sigma_y}{5.34 + 4(c_1/c_2)^2}} \quad (mm)$$

where

$$c_1 = h_w - 0.8h \quad (mm)$$

h_w : web height (mm) of stringer / web frame, see Fig. 3.4.6-1.

h : height (mm) of framing member penetrating the member under consideration, 0 if no such framing member, see Fig. 3.4.6-1.

c_2 : spacing (mm) between supporting structure oriented perpendicular to the member under consideration, see Fig. 3.4.6-1.

σ_y : minimum upper yield stress of the material (N/mm^2)

$$(b) \quad t_{wn} = 0.35 t_{pn} \sqrt{\frac{\sigma_y}{235}} \quad (mm)$$

where

σ_y : minimum upper yield stress of the shell plate in way of the framing member (N/mm^2)

t_{wn} : net thickness (mm) of the web

t_{pn} : net thickness (mm) of the shell plate in way of the framing member

Fig. 3.4.6-1 Parameter Definition for Web Stiffening

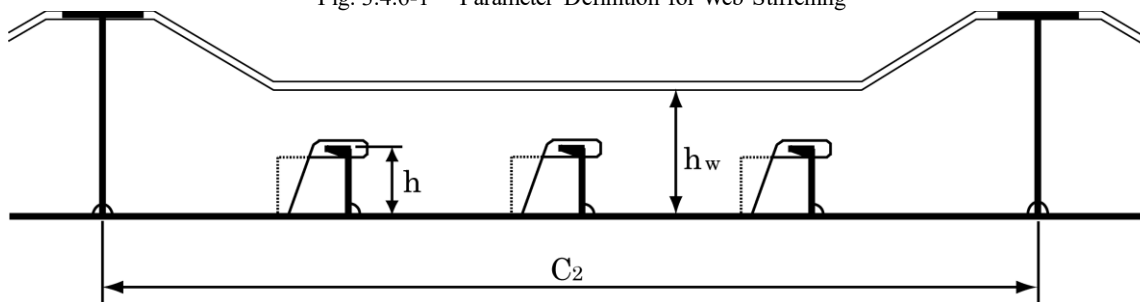

3 To prevent local flange buckling of welded profiles, the following (1) and (2) are to be satisfied:

- (1) The flange width, b_f (mm) is not to be less than five times the net thickness of the web, t_{wn} .
- (2) The flange outstand, b_{out} (mm) is to meet the following requirement:

$$\frac{b_{out}}{t_{fn}} \leq \frac{155}{\sqrt{\sigma_y}}$$

where

t_{fn} : net thickness (mm) of flange

σ_y : minimum upper yield stress of the material (N/mm^2)

3.4.7 Plated Structures

1 Plated structures are those stiffened plate elements in contact with the hull and subject to ice loads. These requirements are applicable to an inboard extent which is the lesser of:

- (1) web height of adjacent parallel web frame or stringer; or
- (2) 2.5 times the depth of framing that intersects the plated structure

2 The thickness of the plating and the scantlings of attached stiffeners are to be such that the degree of end fixity necessary for the shell framing is ensured.

3 The stability of the plated structure is to adequately withstand the ice loads defined in 3.3.

3.4.8 Stem and Stern Frames

The stem and stern frame are to be designed according to the requirements deemed appropriate by the Society. For PC6 and PC7 polar class ships, the stem and stern requirements of Chapter 8, Part I of the Rules may need to be additionally considered.

3.4.9 Bilge Keel

1 The connection of bilge keels to the hull is to be so designed, that the risk of the hull, in case a bilge keel is ripped off, is minimized.

2 It is recommended that bilge keels are cut up into several shorter independent lengths.

3.4.10 Appendages

1 All appendages are to be designed to withstand forces appropriate for the location of their attachment to the hull structure or their position within a hull area.

2 Load definition and response criteria are deemed appropriately by the Society.

3.4.11 Local Details

1 Local design details are to comply with the requirements deemed appropriate by the Society.

2 The collar plate is to be fitted in way of the cut-out for longitudinal penetration in the ice reinforcement region in principle.

3 The loads carried by a member in way of cut-outs are not to cause instability. Where necessary, the structure is to be stiffened.

3.4.12 Direct Calculations

1 Direct calculations are to not to be utilised as an alternative to the analytical procedures prescribed for the shell plating and local frame requirements given in 3.4.1, 3.4.3, and 3.4.4.

2 Direct calculations are to be used for load carrying stringers and web frames forming part of a grillage system.

3 Where direct calculation is used to check the strength of structural systems, the load patch specified in 3.3 is to be applied, without being combined with any other loads. The load patch is to be applied at locations where the capacity of these members under the combined effects of bending and shear is minimised. Special attention is to be paid to the shear capacity in way of lightening holes and cut-outs in way of intersecting members.

4 The strength evaluation of web frames and stringers may be performed based on linear or non-linear analysis. Recognized structural idealisation and calculation methods are to be applied, but the detailed requirements are to be as deemed appropriate by the Society. In the strength evaluation, the guidance given in -5 and -6 may generally be considered.

5 If the structure is evaluated based on linear calculation methods, the following are to be considered:

- (1) Web plates and flange elements in compression and shear to fulfil relevant buckling criteria as deemed appropriate by the Society
- (2) Nominal shear stresses in member web plates to be less than $\sigma_y/\sqrt{3}$
- (3) Nominal von Mises stresses in member flanges to be less than $1.15\sigma_y$

6 If the structure is evaluated based on non-linear calculation methods, the following are to be considered:

- (1) The analysis is to reliably capture buckling and plastic deformation of the structure
- (2) The acceptance criteria are to ensure a suitable margin against fracture and major buckling and yielding causing significant loss of stiffness
- (3) Permanent lateral and out-of plane deformation of considered member are to be minor relative to the relevant structural dimensions
- (4) Detailed acceptance criteria to be as deemed appropriate by the Society

3.4.13 Rudders

The scantlings of rudders are to be determined in consideration of the loads generated by the impact of ice on the rudders.

3.5 Longitudinal Strength

3.5.1 General

1 Ice loads for examination of longitudinal strength in navigating ice-infested polar waters are only to be combined with still water loads.

2 The combined stresses are to be compared against permissible bending and shear stresses at different locations along the ship's length.

3 In addition, sufficient local buckling strength is also to be verified.

3.5.2 Design Vertical Ice Force at the Bow

The design vertical ice force at the bow F_{IB} is to be taken the minimum value of following $F_{IB,1}$ and $F_{IB,2}$.

$$F_{IB,1} = 1000 \times 0.534 K_I^{0.15} \sin^{0.2}(\gamma_{stem}) \sqrt{\frac{\Delta_{UI}}{1000} \frac{K_h}{1000}} C F_L \quad (kN)$$

$$F_{IB,2} = 1000 \times 1.20 C F_F \quad (kN)$$

where

$$K_I: \text{indentation parameter, } K_I = 1000 \frac{K_f}{K_h}$$

where

(a) for the case of a blunt bow form

$$K_f = \left(\frac{2CB_{UI}^{1-e_b}}{1+e_b} \right)^{0.9} \tan(\gamma_{stem})^{-0.9(1+e_b)}$$

(b) for the case of wedge bow form ($\alpha_{stem} < 80 \text{ deg}$), $e_b = 1$ and above simplifies to:

$$K_f = \left(\frac{\tan(\alpha_{stem})}{\tan^2(\gamma_{stem})} \right)^{0.9}$$

$$K_h = 10A_{WP} \quad (kN/m)$$

$C F_L$: Longitudinal Strength Class Factor from [Table 3.3.1-1](#)

e_b : bow shape exponent which best describes the waterplane, see [Fig. 3.5.2-1](#) and [Fig. 3.5.2-2](#)

$e_b = 1.0$ for a simple wedge bow form

$e_b = 0.4$ to 0.6 for a spoon bow form

$e_b = 0$ for a landing craft bow form

An approximate e_b determined by a simple fit is acceptable

γ_{stem} : stem angle (deg) to be measured between the horizontal axis and the stem tangent at the UIWL (buttock angle (deg) as per Fig. 3.3.2-1 measured on the centreline)

α_{stem} : waterline angle (deg) measured in way of the stem at the UIWL, see Fig. 3.5.2-1

$$C = \frac{1}{2 \left(\frac{L_B}{B_{UI}} \right)^{e_b}}$$

B : ship moulded breadth (m) at the UIWL

L_B : bow length (m), see Fig. 3.5.2-1 and Fig. 3.5.2-2.

Δ_{UI} : ship displacement (t) as defined in 1.2.4-3, not to be taken less than 10,000t

A_{wp} : ship waterplane area (m²) at the UIWL

CF_F : Flexural failure class factor from Table 3.3.1-1

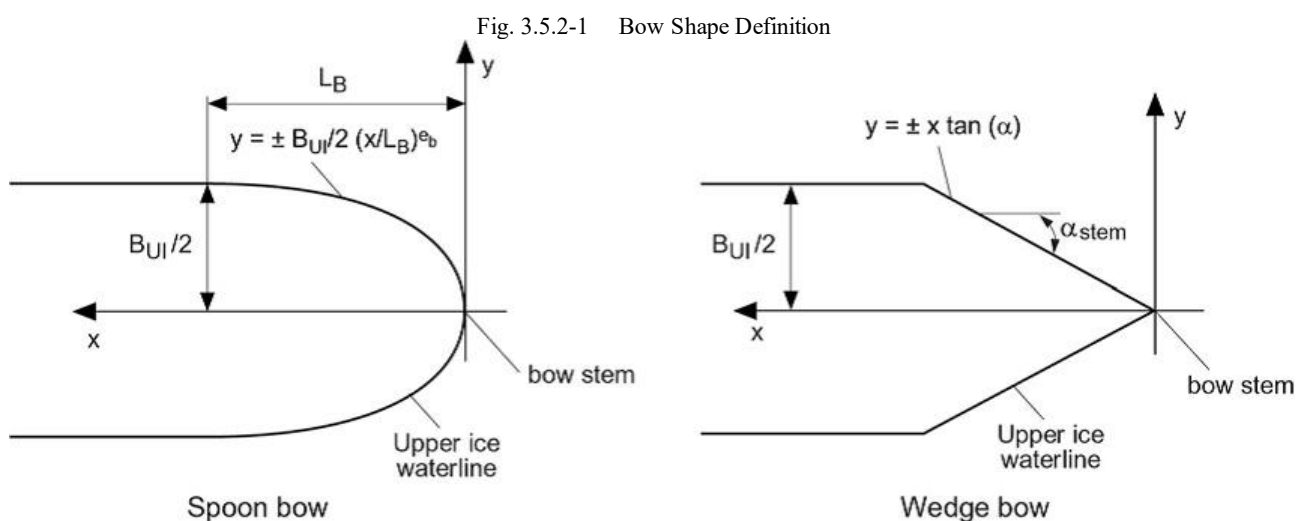
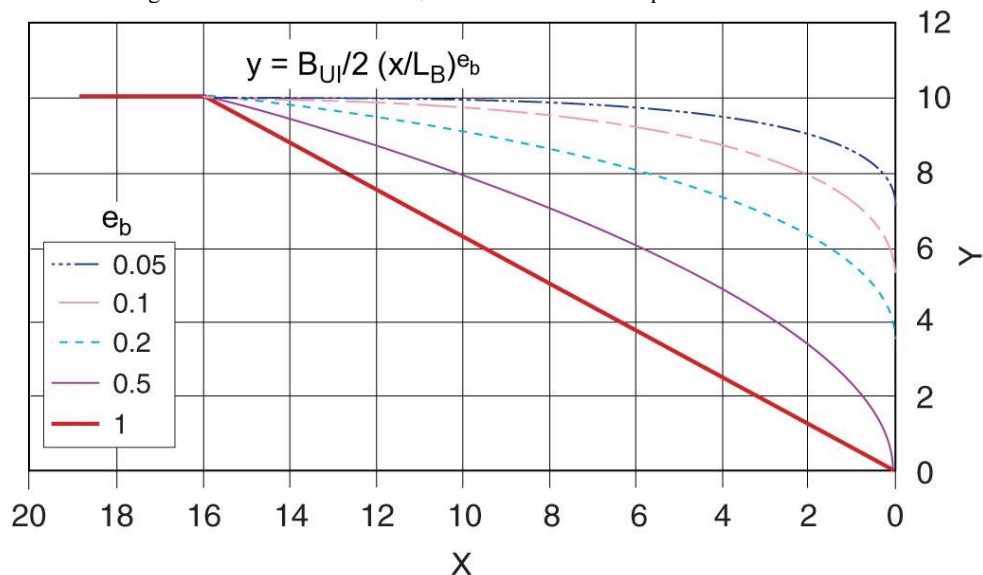

Fig. 3.5.2-2 Illustration of e_b Effect on the Bow Shape for $B=20$ and $L_B=16$



3.5.3 Design Vertical Shear Force

1 The design vertical ice shear force F_I along the hull girder is to be taken as:

$$F_I = C_f F_{IB} \text{ (kN)}$$

where

C_f = longitudinal distribution factor to be taken as follows:

(a) Positive share force

 $C_f = 0.0$ between the aft end of L_{UI} and $0.6L_{UI}$ from aft

 $C_f = 1.0$ between $0.9L_{UI}$ from aft and the forward end of L_{UI}

(b) Negative share force

 $C_f = 0.0$ at the aft end of L_{UI}
 $C_f = -0.5$ between $0.2L_{UI}$ and $0.6L_{UI}$ from aft

 $C_f = 0.0$ between $0.8L_{UI}$ from aft and the forward end of L_{UI}

Intermediate values are to be determined by linear interpolation

2 The applied vertical shear stress τ_a is to be determined along the hull girder in a similar manner as in **5.2.2.2, Part 1, Part C** by substituting the design vertical ice shear force for the design vertical wave shear force.

3.5.4 Design Vertical Ice Bending Moment

1 The design vertical ice bending moment M_I along the hull girder is to be taken as:

$$M_I = 0.1 C_m L_{UI} \sin^{-0.2}(\gamma_{stem}) F_{IB} \quad (kNm)$$

where

 L_{UI} : as given in **1.2.4-2**.

 γ_{stem} : as given in **3.5.2**
 F_{IB} : design vertical ice force (kN) at the bow, see **3.5.2**
 C_m : longitudinal distribution factor for design vertical ice bending moment to be taken as follows:

 $C_m = 0.0$ at the aft end of L
 $C_m = 1.0$ between $0.5L$ and $0.7L$ from aft

 $C_m = 0.3$ at $0.95L$ from aft

 $C_m = 0.0$ at the forward end of L

Intermediate values are to be determined by linear interpolation.

2 The applied vertical bending stress σ_a is to be determined along the hull girder in a similar manner as in **5.2.1.2, Part 1, Part C**, by substituting the design vertical ice bending moment for the design vertical wave bending moment. The ship still water bending moment is to be taken as the permissible still water bending moment in the sagging condition.

3.5.5 Longitudinal Strength Criteria

The strength criteria provided in **Table 3.5.5-1** are to be satisfied. The design stress is not to exceed the permissible stress.

Table 3.5.5-1 Longitudinal Strength Criteria

Failure Mode	Applied Stress	Permissible Stress when	
		$\sigma_y / \sigma_u \leq 0.7$	$\sigma_y / \sigma_u > 0.7$
Tension	σ_a	$\eta \sigma_y$	$\eta \times 0.41 (\sigma_u + \sigma_y)$
Shear	τ_a	$\eta \sigma_y / \sqrt{3}$	$\eta \times 0.41 (\sigma_u + \sigma_y) / \sqrt{3}$
Buckling	σ_a	σ_c for plating and for web plating of stiffeners $\sigma_c / 1.1$ for stiffeners	
	τ_a	τ_c	

Notes:

 σ_a : applied vertical bending stress (N/mm^2)

 τ_a : applied vertical shear stress (N/mm^2)

 σ_y : minimum upper yield stress of the material (N/mm^2)

 σ_u : ultimate tensile strength of material (N/mm^2)

 σ_c : critical buckling stress (N/mm^2) in compression, according to **5.3.3.1(1), Part 1, Part C**
 τ_c : critical buckling stress (N/mm^2) in shear, according to **5.3.3.1(2), Part 1, Part C**
 $\eta = 0.8$. However, for ships which are assigned the additional notation "Icebreaker" (abbreviated to ICB), $\eta = 0.6$.

Chapter 4 MACHINERY INSTALLATIONS

4.1 General

4.1.1 Scope

1 The requirements of this chapter apply to main propulsion, steering gear, emergency and essential auxiliary systems essential for the safety of the ship and survivability of the crew.

2 Ship operating conditions are to be in accordance with [Chapter 1](#).

3 This **chapter** applies in addition to requirements applicable to ships operating in open water.

4.1.2 Drawings and Data

Drawings and data to be submitted in this chapter are as follows:

- (1) Details of the intended environmental operational conditions and the required polar class for the machinery, if different from the polar class of hull structure
- (2) Detailed drawings and descriptions of the main propulsion, steering, emergency and auxiliary systems (including information on essential main propulsion load control functions)
- (3) Operational limitations of the main propulsion, steering, emergency and auxiliaries
- (4) Descriptions detailing where main, emergency and auxiliary systems are located and how they are protected to prevent problems from freezing, ice and snow accumulation
- (5) Evidence of their capability to operate in intended environmental conditions
- (6) Calculations and documentation indicating compliance with the requirements of this chapter
- (7) Drawings and data which are deemed necessary by the Society

4.1.3 System Design

1 Additional fire safety measures are to be arranged in accordance with the requirements in [5.2.3](#), [7.4](#), [10.2.1-2](#), [10.5.3-1](#) and [10.5.5-2](#), **Part R of the Rules**.

2 Any automation plant (control, alarm, safety and indication systems) for essential systems installed is to be maintained in accordance with the requirements in [Chapter 4 of the Rules for Automatic and Remote Control Systems](#).

3 Systems subject to damage by freezing are to be drainable.

4 Polar class ships classed *PC1* to *PC5* are to have means provided to ensure sufficient vessel operation in the case of propeller damage including a controllable pitch mechanism.

5 “Sufficient vessel operation” means that vessels are to be able to reach safe haven (i.e. a safe location) where repairs can be undertaken. This may be achieved either by temporary repairs at sea or by towing, assuming either is available under conditions approved by the Society.

6 Means are to be provided to free stuck propellers by turning in the reverse direction. This is to also be possible for propulsion plants intended for unidirectional rotation.

7 Propellers are to be fully submerged at the *LIWL*.

4.2 Materials

4.2.1 General

1 Materials for machinery parts are to be in accordance with [2.1.5](#), [2.1.6](#) and [2.1.7](#).

2 Materials for machinery parts are to be ductile material approved by the Society.

3 Ferritic nodular cast iron may be used for machinery parts other than bolts. In such cases, the values of average absorbed energy at the testing temperatures specified in [2.1.5](#), [2.1.6](#) and [2.1.7](#) are to be applied at 10 *J*.

4.3 Definitions

4.3.1 Definition of Symbols

Symbols are as defined in [Table 4.3.1-1](#).

Table 4.3.1-1 Definition of Symbols

Symbol	Unit	Definition
c	m	chord length of blade section
$c_{0.7}$	m	chord length of blade section at $0.7R$ propeller radius
D	m	propeller diameter
d	m	external diameter of propeller hub (at propeller plane)
d_{pin}	mm	diameter of shear pin
D_{limit}	m	limit value for propeller diameter
EAR	-	expanded blade area ratio
F_b	kN	maximum backward blade force for the ship's service life (negative value)
F_{ex}	kN	ultimate blade load resulting from blade failure through plastic bending
F_f	kN	maximum forward blade force for the ship's service life (positive value)
F_{ice}	kN	ice load on propeller blade
$(F_{ice})_{max}$	kN	maximum ice load for the ship's service life
h_0	m	depth of the propeller centreline from lower ice waterline ($LIWL$)
(H_{ice})	m	ice block dimension for propeller load definition
I	kgm^2	equivalent mass moment of inertia of all parts on engine side of component under consideration
I_t	kgm^2	equivalent mass moment of inertia of the whole propulsion system
k	-	shape parameter for Weibull distribution
m	-	slope for S-N curve in log/log scale
M_{BL}	kNm	blade bending moment
MCR	-	maximum continuous rating
N	-	number of ice load cycles
n	rpm	propeller rotational speed
n_n	rpm	nominal propeller rotational speed at MCR in free running condition
N_{class}	-	reference number of ice impacts per propeller revolution per ice class
N_{ice}	-	total number of ice load cycles on propeller blade for the ship's service life
N_R	-	reference number of ice load cycles for equivalent fatigue stress (10^8 cycles)
N_Q	-	number of propeller revolutions during a milling sequence

$P_{0.7}$	m	propeller pitch at $0.7R$ radius
$P_{0.7n}$	m	propeller pitch at $0.7R$ radius at MCR in free running open water condition
$P_{0.7b}$	m	propeller pitch at $0.7R$ radius at MCR in bollard condition
PCD	m	pitch circle diameter
$Q(\varphi)$	kNm	Torque
Q_{Amax}	kNm	maximum response torque amplitude as a simulation result
Q_{emax}	kNm	maximum engine torque
$Q_F(\varphi)$	kNm	Ice torque excitation for frequency domain calculations
Q_{fr}	kNm	friction torque in pitching mechanism; reduction of spindle torque
Q_{max}	kNm	maximum torque on the propeller resulting from propeller/ice interaction
Q_{motor}	kNm	electric motor peak torque
Q_n	kNm	nominal torque at MCR in free running open water condition
$Q_r(t)$	kNm	response torque along the propeller shaft line
Q_{peak}	kNm	maximum of the response torque $Q_r(t)$
Q_{smax}	kNm	maximum spindle torque of the blade for the ship's service life
Q_{sex}	kNm	extreme spindle torque corresponding to the blade failure load F_{ex}
Q_{vib}	kNm	Vibratory torque at considered component, taken from frequency domain open water Torsional Vibration Calculation (TVC)
R	m	propeller radius
S	-	safety factor
S_{fat}	-	safety factor for fatigue
S_{ice}	-	ice strength index for blade ice force
r	m	blade section radius
T	kN	hydrodynamic propeller thrust in bollard condition
T_b	kN	maximum backward propeller ice thrust for the ship's service life
T_f	kN	maximum forward propeller ice thrust for the ship's service life
T_n	kN	propeller thrust at MCR in free running condition
T_r	kN	maximum response thrust along the shaft line
T_{kmax}	kNm	maximum torque capacity of flexible coupling
T_{kmax2}	kNm	T_{kmax} at $N = 1$ load cycle
T_{max1}	kNm	T_{kmax} at $N = 5 \times 10^4$ load cycle
T_{kv}	kNm	vibratory torque amplitude at $N = 10^6$ load cycles
ΔT_{kmax}	kNm	maximum range of T_{kmax} at $N = 5 \times 10^4$ load

		cycles
t	m	maximum blade section thickness
z	-	number of propeller blades
z_{pin}	-	number of shear pins
α_i	deg	duration of propeller blade/ice interaction expressed in rotation angle
γ_ε	-	the reduction factor for fatigue; scatter and test specimen size effect
γ_v	-	the reduction factor for fatigue; variable amplitude loading effect
γ_m	-	the reduction factor for fatigue; mean stress effect
ρ	-	a reduction factor for fatigue correlating the maximum stress amplitude to the equivalent fatigue stress for 10^8 stress cycles
$\sigma_{0.2}$	MPa	proof yield strength (at 0.2 % plastic strain) of material
σ_{exp}	MPa	mean fatigue strength of blade material at 10^8 cycles to failure in sea water
σ_{fat}	MPa	equivalent fatigue ice load stress amplitude for 10^8 stress cycles
σ_{fl}	MPa	characteristic fatigue strength for blade material
σ_{ref1}	MPa	reference stress $\sigma_{ref1} = 0.6\sigma_{0.2} + 0.4\sigma_u$
σ_{ref2}	MPa	reference stress whichever is less $\sigma_{ref2} = 0.7\sigma_u$ or $\sigma_{ref2} = 0.6\sigma_{0.2} + 0.4\sigma_u$
σ_{st}	MPa	maximum stress resulting from F_b or F_f
σ_u	MPa	ultimate tensile strength of blade material
$(\sigma_{ice})_{bmax}$	MPa	principal stress caused by the maximum backward propeller ice load
$(\sigma_{ice})_{fmax}$	MPa	principal stress caused by the maximum forward propeller ice load
σ_{mean}	MPa	mean stress
$(\sigma_{ice})_A(N)$	MPa	blade stress amplitude distribution

4.3.2 Definition of Loads

Loads are as defined in [Table 4.3.2-1](#).

Fig. 4.3.2-1 Direction of the Backward Blade Force resultant taken Perpendicular to the Chord Line at Radius 0.7R. (Ice contact pressure at leading edge is shown with small arrows.)

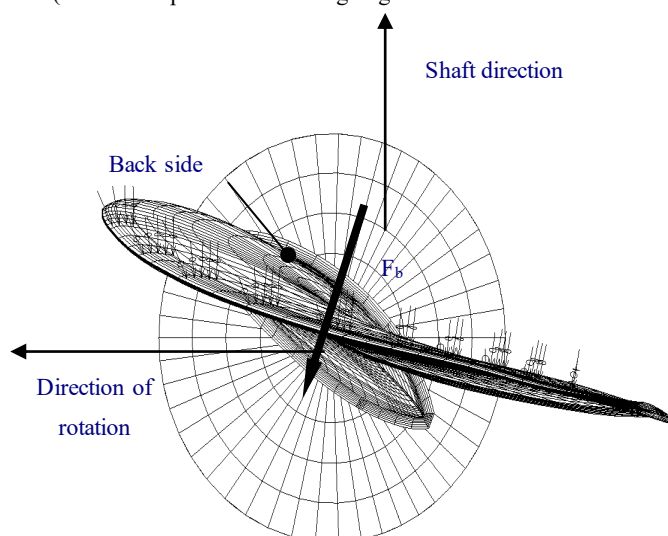

Table 4.3.2-1 Definition of Loads

	Definition	Use of the load in design process
F_b	The maximum lifetime backward force on a propeller blade resulting from propeller/ice interaction, including hydrodynamic loads on that blade. The direction of the force is perpendicular to 0.7R chord line. (See Fig. 4.3.2-1)	Design force for strength calculation of the propeller blade.
F_f	The maximum lifetime forward force on a propeller blade resulting from propeller/ice interaction, including hydrodynamic loads on that blade. The direction of the force is perpendicular to 0.7R chord line.	
Q_{smax}	The maximum lifetime spindle torque on a propeller blade resulting from propeller/ice interaction, including hydrodynamic loads on that blade.	In designing the propeller strength, the spindle torque is automatically taken into account because the propeller load is acting on the blade as distributed pressure on the leading edge or tip area.
T_b	The maximum lifetime thrust on propeller (all blades) resulting from propeller/ice interaction. The direction of the thrust is the propeller shaft direction and the force is opposite to the hydrodynamic thrust.	Is used for estimation of the response thrust T_r , T_b and T_f can be used as an estimate of excitation for axial vibration calculations. However, axial vibration calculations are not required in the rules.
T_f	The maximum lifetime thrust on	

	propeller (all blades) resulting from propeller/ice interaction. The direction of the thrust is the propeller shaft direction acting in the direction of hydrodynamic thrust.	
Q_{max}	The maximum ice-induced torque resulting from propeller/ice interaction on one propeller blade, including hydrodynamic loads on that blade.	Is used for estimation of the response torque Q_r along the propulsion shaft line and as excitation for torsional vibration calculations.
F_{ex}	Ultimate blade load resulting from blade loss through plastic bending. The force that is needed to cause total failure of the blade so that plastic hinge is caused to the root area. The force is acting on $0.8R$.	Blade failure load is used to dimension the blade bolts, pitch control mechanism, propeller shaft, propeller shaft bearing and trust bearing. The objective is to guarantee that total propeller blade failure should not cause damage to other components.
Q_{sex}	Maximum spindle torque resulting from blade failure load	Is used to ensure pyramid strength principle for the pitching mechanism
Q_r	Maximum response torque along the propeller shaft line, taking into account the dynamic behaviour of the shaft line for ice excitation (torsional vibration) and hydrodynamic mean torque on propeller.	Design torque for propeller shaft line components.
T_r	Maximum response thrust along shaft line, taking into account the dynamic behaviour of the shaft line for ice excitation (axial vibration) and hydrodynamic mean thrust on propeller.	Design thrust for propeller shaft line components.

4.4 Design Loads

4.4.1 General

1 In the design of the propeller, propulsion shafting system and power transmission system, the following are to be taken into account.

- (1) Maximum backward blade force
- (2) Maximum forward blade force
- (3) Maximum blade spindle torque
- (4) Maximum propeller ice torque
- (5) Maximum propeller ice thrust
- (6) Design torque on propulsion shafting system
- (7) Maximum thrust on propulsion shafting system
- (8) Blade failure load

- 2 The loads specified in -1 are to comply with the following:
- (1) The ice loads cover open and ducted type propellers situated at the stern of a ship having controllable pitch or fixed pitch blades. Ice loads on bow mounted propellers are to receive special consideration.
 - (2) The given loads in this chapter are expected, single occurrence, maximum values for the whole ships service life for normal operation conditions, including loads resulting from directional change of rotation where applicable. The loads do not cover off-design operational conditions, for example when a stopped propeller is dragged through ice.
 - (3) The loads apply also for propeller ice interaction for azimuthing and fixed thrusters with geared transmissions or integrated electric motors (i.e. “geared and podded propulsors”). However, such load models do not include propeller/ice interaction loads when ice enters the propeller of turned azimuthing thrusters from the side (i.e. radially) or loads when ice blocks hit the propeller hubs of pulling propellers. Ice loads resulting from ice impacts on the body of azimuthing thrusters are to be estimated on a case by case basis.
 - (4) The loads are total loads including ice-induced loads and hydrodynamic loads (unless otherwise stated) during ice interaction that are to be applied separately (unless otherwise stated) and are intended for component strength calculations only.
 - (5) The load specified in -1(1) above is the maximum force experienced during the lifetime of the ship that bends propeller blades backwards when propellers mill ice blocks while rotating ahead. The load specified in -1(2) above is the maximum force experienced during the lifetime of the ship that bends propeller blades forwards when propellers mill ice blocks while rotating ahead. Since these loads originate from different propeller/ice interaction phenomena, which do not act simultaneously, they are to be applied separately.

4.4.2 Polar Class Factors

- 1 The ice thickness H_{ice} (m) and the ice strength index S_{ice} for each polar class are to be taken as specified in Table 4.4.2-1.
- 2 The design ice block to be considered is to be obtained by the following formula:

$$H_{ice} \times 2H_{ice} \times 3H_{ice} \text{ (m)}$$
- 3 The design ice block H_{ice} and ice strength index S_{ice} are to be used for the estimation of propeller ice loads.

Table 4.4.2-1 Values of H_{ice} and S_{ice}

Polar class	H_{ice}	S_{ice}
PC1	4.0	1.2
PC2	3.5	1.1
PC3	3.0	1.1
PC4	2.5	1.1
PC5	2.0	1.1
PC6	1.75	1
PC7	1.5	1

4.4.3 Maximum Backward Blade Force

1 The maximum backward blade force which bends a propeller blade backwards when a propeller mills an ice block while rotating ahead is to be given by the following formulae:

- (1) For open propellers:

$$\text{when } D < D_{\text{limit}} \\ F_b = 27S_{ice} \left(\frac{n}{60}D\right)^{0.7} \left(\frac{EAR}{Z}\right)^{0.3} D^2 \text{ (kN)}$$

$$\text{when } D \geq D_{\text{limit}} \\ F_b = 23S_{ice}(H_{ice})^{1.4} \left(\frac{n}{60}D\right)^{0.7} \left(\frac{EAR}{Z}\right)^{0.3} D \text{ (kN)}$$

$$\text{where } D_{\text{limit}} = 0.85(H_{ice})^{1.4} \text{ (m)}$$

- (2) For ducted propellers :

$$\text{when } D < D_{\text{limit}} \\ F_b = 9.5S_{ice} \left(\frac{n}{60}D\right)^{0.7} \left(\frac{EAR}{Z}\right)^{0.3} D^2 \text{ (kN)}$$

$$\text{when } D \geq D_{\text{limit}}$$

$$F_b = 66S_{ice}(H_{ice})^{1.4} \left(\frac{n}{60}D\right)^{0.7} \left(\frac{EAR}{Z}\right)^{0.3} D^{0.6} \text{ (kN)}$$

where $D_{limit} = 4H_{ice}$ (m)

D : Propeller diameter (m)

EAR : Expanded blade area ratio

n : Nominal rotational propeller speed (rpm) at maximum continuous revolutions in free running condition for controllable pitch propellers and 85% of the nominal rotational propeller speed at maximum continuous revolutions in free running condition for fixed pitch propellers (regardless of driving engine type)

2 For ships affixed with the additional notation “Icebreaker” (abbreviated to *ICB*), the maximum backward blade force F_b specified in -1 above is to be multiplied by a factor of 1.1.

3 The maximum backward blade force F_b is to be applied as a uniform pressure distribution to an area of the blade for the following load cases as specified in [Table 4.4.5-1](#) and [Table 4.4.5-2](#).

(1) For open propellers:

(a) Load case 1 in [Table 4.4.5-1](#)

(b) Load case 2 in [Table 4.4.5-1](#)

(c) For reversible propellers, Load case 5 in [Table 4.4.5-1](#)

(2) For ducted propellers:

(a) Load case 1 in [Table 4.4.5-2](#)

(b) For reversible propellers, Load case 5 in [Table 4.4.5-2](#)

4.4.4 Maximum Forward Blade Force

1 Maximum forward blade force which bends a propeller blade forwards when a propeller interacts with an ice block while rotating ahead is to be given by the following formulae:

(1) For open propellers:

when $D < D_{limit}$

$$F_f = 250 \left(\frac{EAR}{Z}\right) D^2 \text{ (kN)}$$

when $D \geq D_{limit}$

$$F_f = 500H_{ice} \left(\frac{EAR}{Z}\right) \left(\frac{1}{1-\frac{d}{D}}\right) D \text{ (kN)}$$

$$\text{where } D_{limit} = \frac{2}{\left(1-\frac{d}{D}\right)} H_{ice} \text{ (m)}$$

(2) For ducted propellers:

when $D \leq D_{limit}$

$$F_f = 250 \left(\frac{EAR}{Z}\right) D^2 \text{ (kN)}$$

when $D > D_{limit}$

$$F_f = 500H_{ice} \left(\frac{EAR}{Z}\right) \left(\frac{1}{1-\frac{d}{D}}\right) D \text{ (kN)}$$

$$\text{where } D_{limit} = \frac{2}{\left(1-\frac{d}{D}\right)} H_{ice} \text{ (m)}$$

d : Propeller boss diameter (m)

Z : Number of propeller blades

2 The maximum forward blade force F_f is to be applied as a uniform pressure distribution to an area of the blade for the following load cases as specified in [Table 4.4.5-1](#) and [Table 4.4.5-2](#).

(1) For open propellers:

(a) Load case 3 in [Table 4.4.5-1](#)

(b) Load case 4 in [Table 4.4.5-1](#)

(c) For reversible propellers, Load case 5 in [Table 4.4.5-1](#)

(2) For ducted propellers:

(a) Load case 3 in [Table 4.4.5-2](#)

(b) For reversible propellers, Load case 5 in [Table 4.4.5-2](#)

4.4.5 Loaded area on the blade

Loaded area on the blade of the Maximum forward blade force and maximum backward blade force are to be in accordance with [Table 4.4.5-1](#) and [Table 4.4.5-2](#).

Table 4.4.5-1 Load Cases for Open Propeller

	Force	Loaded area	Right handed propeller blade seen from back
Load case 1	F_b	Uniform pressure applied on the back of the blade (suction side) to an area from $0.6R$ to the tip and from the leading edge to 0.2 times the chord length	
Load case 2	50% of F_b	Uniform pressure applied on the back of the blade (suction side) on the propeller tip area outside of $0.9R$ radius	
Load case 3	F_f	Uniform pressure applied on the blade face (pressure side) to an area from $0.6R$ to the tip and from the leading edge to 0.2 times the chord length	
Load case 4	50% of F_f	Uniform pressure applied on the propeller face (pressure side) on the propeller tip area outside of $0.9R$ radius	
Load case 5	60% of F_f or F_b which one is greater	Uniform pressure applied on propeller face (pressure side) to an area from $0.6R$ to the tip and from the trailing edge to 0.2 times the chord length	

Table 4.4.5-2 Load Cases for Ducted Propeller

	Force	Loaded area	Right handed propeller blade seen from back
Load case 1	F_b	Uniform pressure applied on the back of the blade (suction side) to an area from $0.6R$ to the tip and from the leading edge to 0.2 times the chord length	
Load case 3	F_f	Uniform pressure applied on the blade face (pressure side) to an area from the leading edge to 0.5 times the chord length	
Load case 5	60% of F_f or F_b which one is greater	Uniform pressure applied on propeller face (pressure side) to an area from $0.6R$ to the tip and from the trailing edge to 0.2 times the chord length	

4.4.6 Maximum Blade Spindle Torque

Spindle torque around the spindle axis of the blade fitting is to be calculated both for the load case specified in 4.4.3 and 4.4.4 for F_b and F_f . Where these spindle torque values are less than the default value obtained from the following formula, the default value is to be used.

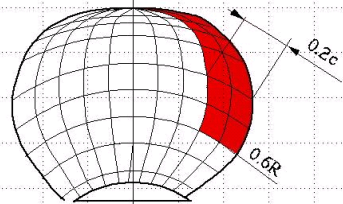
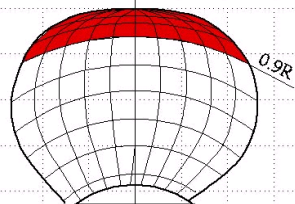
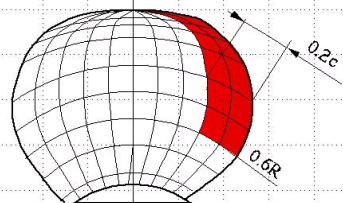
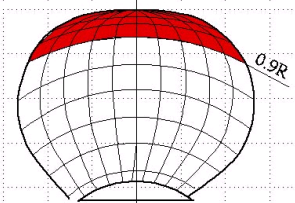
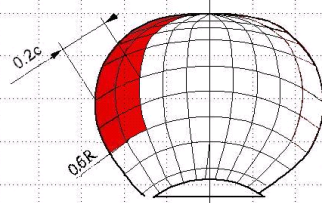
$$Q_{smax} = 0.25FC_{0.7} \text{ (kNm)}$$

where:

$C_{0.7}$: Length (m) of the blade chord at $0.7R$ radius

F : Either F_b determined in 4.4.3-1 or F_f determined in 4.4.4-1, whichever has the greater absolute value.

4.4.7 Frequent Distributions for Propeller Blade Loads

1 A Weibull-type distribution (probability that F_{ice} exceeds $(F_{ice})_{max}$), as given in Fig. 4.4.7-1, is to be used for the fatigue design of blades.

$$P\left(\frac{F_{ice}}{(F_{ice})_{max}} \geq \frac{F}{(F_{ice})_{max}}\right) = \exp\left(-\left(\frac{F}{(F_{ice})_{max}}\right)^k \ln(N_{ice})\right)$$

where

F_{ice} : Random variable for ice loads (kN) on the blade that satisfies $0 \leq F_{ice} \leq (F_{ice})_{max}$

$(F_{ice})_{max}$: Maximum ice load for ship's service life (kN)

k : Shape parameter for the Weibull-type distribution in which the following definitions apply:

Open propeller: $k=0.75$

Ducted propeller: $k=1.0$

N_{ice} : Total number of ice loads on propeller blade for ship's service life

2 A blade stress amplitude distribution in accordance with -1 above is to be determined in accordance with the formula:

$$(\sigma_{ice})_A(N) = (\sigma_{ice})_{Amax} \cdot \left(1 - \frac{\log(N)}{\log(N_{ice})}\right)^{\frac{1}{k}}$$

where

$$(\sigma_{ice})_{Amax} = \frac{(\sigma_{ice})_{fmax} - (\sigma_{ice})_{bmax}}{2}$$

Fig. 4.4.7-1 Weibull-type Distribution (probability that F_{ice} exceeds $(F_{ice})_{max}$)
Used for Fatigue Designs

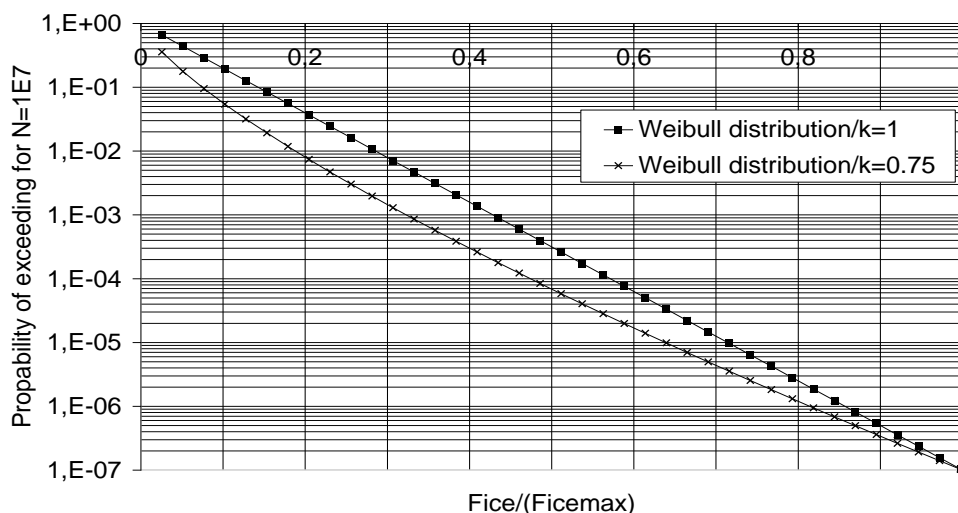

4.4.8 Number of Ice Loads

1 The number of load cycles per propeller blade in the load spectrum is to be determined according to the following formula:

$$N_{ice} = k_1 k_2 N_{class} \frac{n_n}{60}$$

where

N_{class} : Reference number of loads for ice classes, as specified in [Table 4.4.8-1](#)

n_n : Nominal propeller rotational speed at maximum continuous revolutions in free running condition (*rpm*)

k_1 : Propeller location factor, as specified in [Table 4.4.8-2](#)

k_2 : The submersion factor k_2 is determined from the following equation.

$$k_2 = \begin{cases} 0.8 - f & : f < 0 \\ 0.8 - 0.4f & : 0 \leq f \leq 1 \\ 0.6 - 0.2f & : 1 < f \leq 2.5 \\ 0.1 & : f > 2.5 \end{cases}$$

where

$$f = \frac{h_0 - H_{ice}}{D/2} - 1$$

h_0 : The depth of the propeller centreline at the lower ice waterline (*LIWL*) of the ship (*m*). If h_0 is not known,

$$h_0 = 2/D.$$

Table 4.4.8-1 Reference Number of Loads for Polar Classes N_{class}

Polar class	PC1	PC2	PC3	PC4	PC5	PC6	PC7
N_{class}	$21 \cdot 10^6$	$17 \cdot 10^6$	$15 \cdot 10^6$	$13 \cdot 10^6$	$11 \cdot 10^6$	$9 \cdot 10^6$	$6 \cdot 10^6$

Table 4.4.8-2 Propeller Location Factor k_l

Factor	Centre propeller Bow first operation	Wing propeller Bow first operation	Pulling propeller (wing and centre) Bow propeller or Stern first operation
k_l	1	2	3

2 For ships is affixed with the additional notation “Icebreaker” (abbreviated to *ICB*), the number of loads specified in -1 above is to be multiplied by a factor of 3.

3 For components that are subject to loads resulting from propeller/ice interaction with the propeller blades, the number of load cycles (N_{class}) is to be multiplied by the number of propeller blades (Z).

4.4.9 Blade Failure Load

1 Bending Force, F_{ex}

(1) Bending force is to be obtained by the following formula:

$$F_{ex} = \frac{0.3ct^2\sigma_{ref}}{0.8D-2r} \times 10^3 \text{ (kN)}$$

where

$$\sigma_{ref1} = 0.6\sigma_{0.2} + 0.4\sigma_u \text{ (MPa)}$$

σ_u : Minimum tensile stress of blade material (MPa)

$\sigma_{0.2}$: Minimum yield stress or 0.2% proof strength of blade material (MPa)

c , t and r : The actual chord length, thickness and radius of the cylindrical root section of the blade at the weakest section outside root fillet (typically will be at the termination of the fillet into the blade profile), respectively

(2) The bending force in (1) above is the minimum load required resulting in blade failure through plastic bending, and is to be calculated iteratively along the radius of the blade root to $0.5R$ assumed to be acting at $0.8R$ in the weakest direction.

(3) Blade failure loads may be obtained alternatively by means of an appropriate stress analysis, reflecting the non-linear plastic material behaviour of the actual blade. In such cases, blade failure areas may be outside root sections. Blades are regarded as having failed if their tips are bent into offset positions by more than 10 % of the propeller diameter D .

2 Spindle Torque, Q_{sex}

(1) The maximum spindle torque due to a blade failure load acting at $0.8R$ is to be determined. The force that causes blade failure typically reduces when moving from the propeller centre towards the leading and trailing edges, and maximum spindle torque will occur at certain distances from the blade centre of rotation. This maximum spindle torque is to be defined by an appropriate stress analysis or by using the following equation:

$$Q_{sex} = \max(C_{LE0.8}; 0.8C_{TE0.8})C_{spex}F_{ex} \text{ (kNm)}$$

where

$$C_{spex} = C_{sp}C_{fex} = 0.7 \left(1 - \left(\frac{4EAR}{Z} \right)^3 \right)$$

C_{sp} : Non-dimensional parameter taking into account the spindle arm

C_{fex} : Non-dimensional parameter taking into account the reduction of blade failure force at the location of maximum spindle torque

$C_{LE0.8}$: Leading edge portion of the chord length at $0.8R$

$C_{TE0.8}$: Trailing edge portion of the chord length at $0.8R$

If C_{spex} is below 0.3, a value of 0.3 is to be used for C_{spex} .

(2) Spindle torque values due to blade failure loads across the entire chord length area are shown in [Fig. 4.4.9-1](#).

Fig. 4.4.9-1 Schematic figure showing blade failure loads and related spindle torques when force acts at different locations on

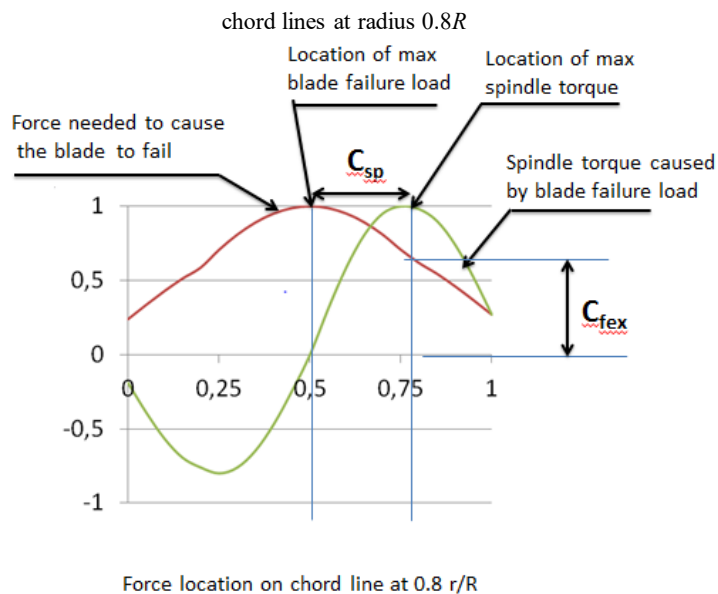

4.4.10 Maximum Propeller Ice Thrust

Maximum propeller ice torque applied to the shaft is to be given by the following formulae. However, the propeller/ice interaction loads where an ice blocks hit the propeller hubs of pulling propellers are not to be included.

- (1) Maximum forward propeller ice thrust

$$T_f = 1.1 F_f \text{ (kN)}$$

- (2) Maximum backward propeller ice thrust

$$T_b = 1.1 F_b \text{ (kN)}$$

where

F_f : As determined in 4.2.3-1

F_b : As determined in 4.2.2-1

4.4.11 Design Thrust along Propulsion Shaft Lines

1 Design thrust along the propeller shaft line is to be given by the following formulae. The greater value of the forward and backward directional load is to be taken as the design load for both directions.

- (1) Maximum shaft thrust forwards:

$$T_r = T + 2.2T_f \text{ (kN)}$$

- (2) Maximum shaft thrust backwards:

$$T_r = 1.5T_b \text{ (kN)}$$

where:

T : Propeller bollard thrust (kN) If not known, T_n is to be taken as specified in [Table 4.4.11-1](#)

T_f and T_b : Maximum propeller ice thrust (kN) determined in [4.4.10](#)

2.2 and 1.5: Thrust magnification factors due to axial vibration

- 2 For pulling type propellers the ice interaction loads on propeller hubs are to be considered in addition to -1 above.

Table 4.4.11-1 Value of T

Propeller type	T
Controllable pitch propellers (open)	$1.25T_n$
Controllable pitch propellers (ducted)	$1.1T_n$
Fixed pitch propellers driven by turbine or electric motor	T_n
Fixed pitch propellers driven by diesel engine (open)	$0.85T_n$
Fixed pitch propellers driven by diesel engine (ducted)	$0.75T_n$

Note

T_n : Nominal propeller thrust (kN) at maximum continuous revolutions in free running open water conditions

4.4.12 Maximum Propeller Ice Torque

Maximum propeller ice torque applied to the propeller is to be given by the following formulae:

(1) For open propellers:

when $D < D_{limit}$

$$Q_{max} = k_{open} \left(1 - \frac{d}{D}\right) \left(\frac{P_{0.7}}{D}\right)^{0.16} \left(\frac{n}{60D}\right)^{0.17} D^3 \quad (kNm)$$

when $D \geq D_{limit}$

$$Q_{max} = 1.9k_{open} \left(1 - \frac{d}{D}\right) (H_{ice})^{1.1} \left(\frac{P_{0.7}}{D}\right)^{0.16} \left(\frac{n}{60D}\right)^{0.17} D^{1.9} \quad (kNm)$$

where $D_{limit} = 1.8H_{ice}$ (m)

k_{open} : Factor for open propeller of each polar class is given below.

$$PC1 \text{ to } PC5 \quad k_{open} = 14.7$$

$$PC6 \text{ to } PC7 \quad k_{open} = 10.9$$

(2) For ducted propellers:

when $D < D_{limit}$

$$Q_{max} = k_{ducted} \left(1 - \frac{d}{D}\right) \left(\frac{P_{0.7}}{D}\right)^{0.16} \left(\frac{n}{60D}\right)^{0.17} D^3 \quad (kNm)$$

when $D \geq D_{limit}$

$$Q_{max} = 1.9k_{ducted} \left(1 - \frac{d}{D}\right) (H_{ice})^{1.1} \left(\frac{P_{0.7}}{D}\right)^{0.16} \left(\frac{n}{60D}\right)^{0.17} D^{1.9} \quad (kNm)$$

where: $D_{limit} = 1.8H_{ice}$ (m)

k_{ducted} : Factor for open propeller of each polar class is given below.

$$PC1 \text{ to } PC5 \quad k_{ducted} = 10.4$$

$$PC6 \text{ to } PC7 \quad k_{ducted} = 7.7$$

$P_{0.7}$: Propeller pitch (m) at $0.7R$

For controllable pitch propellers, $P_{0.7}$ is to correspond to maximum continuous revolutions in bollard condition. If not known, $P_{0.7}$ is to be taken as $0.7 P_{0.7n}$, where $P_{0.7n}$ is propeller pitch at maximum continuous revolutions in free running open water condition.

n : Rotational propeller speed (rpm) at bollard condition

If not known, n is to be taken as specified in [Table 4.4.12-1](#).

Table 4.4.12-1 Rotational Propeller Speed

Propeller type	n
Controllable pitch propellers	n_n
Fixed pitch propellers driven by turbine or electric motor	n_n
Fixed pitch propellers driven by diesel engine	$0.85n_n$

Note:

n_n : Nominal rotational speed (rpm) at maximum continuous revolutions in free running condition

4.4.13 Ice Torque Excitations

1 General

- (1) The given excitations are used to estimate the maximum torque likely to be experienced once during the service life of the ship. The load cases in this paragraph are intended to reflect the operational loads on the propulsion system when the propeller interacts with ice and the corresponding reaction of the complete system. The ice impact and system response cause loads in the individual shaft line components. The ice torque Q_{max} may be taken as a constant value in the complete speed range. When considerations at specific shaft speeds are performed a relevant Q_{max} may be calculated using the relevant speed.
- (2) Diesel engine plants without an elastic coupling are to be calculated at the least favourable phase angle for ice versus engine excitation, when calculated in time domain. In addition, engine firing pulses are to be included in the calculations and their standard steady state harmonics can be used. The phase angles between ice and gas force excitation do not need to be considered in frequency domain analyses, and misfiring does not need to be considered at all.
- (3) If there is a blade order resonance just above *MCR* speed, calculations are to cover the rotational speeds up to 105 % of *MCR* speed.
- (4) See 4.4.15.

2 Time domain calculation

- (1) The propeller ice excitation torque for shaft line transient dynamic analysis in the time domain is defined as a sequence of blade impacts which are of half sine shape and occur at the blade. The torque due to a single blade ice impact as a function of the propeller rotation angle is then given by the following formulae:

- (a) when $0 \leq \varphi - 360x \leq \alpha_i$ (deg)

$$Q(\varphi) = C_q Q_{max} \sin(\varphi(180/\alpha_i))$$

- (b) when $\alpha_i \leq \varphi - 360x \leq 360$ (deg)

$$Q(\varphi) = 0$$

where

φ : Rotation angle from when the first impact occurs

X : Integer revolutions from the time of first impact

C_q : As specified in [Table 4.4.13-1](#)

α_i : Duration of propeller blade/ice interaction expressed in rotation angle as specified in [Table 4.4.13-1](#)

- (2) Total ice torque is obtained by summing the torque of single blades, while taking account of the phase shift $360 \text{ deg} / Z$.
- (3) At the beginnings and ends of milling sequences (within the calculated duration), linear ramp functions are to be used to increase C_q to its maximum value within one propeller revolution and vice versa to decrease it to zero.
- (4) The number of propeller revolutions and the number of impacts during milling sequences are to be obtained by the following formulae.

- (a) Number of propeller revolutions:

$$N_Q = 2H_{ice}$$

- (b) The number of impacts:

$$ZN_Q$$

where

Z : Number of propeller blades

Examples of all excitation cases for different numbers of blades are showing in [Fig. 4.4.13-1](#) and [Fig. 4.4.13-2](#).

- (5) Dynamic simulation is to be performed for all excitation cases starting at *MCR* nominal, *MCR* bollard condition and just above all resonance speeds (1st engine and 1st blade harmonic), so that resonant vibration responses can be obtained. For fixed pitch propeller plants, such dynamic simulation is to also cover the bollard pull condition with a corresponding speed assuming maximum possible output of the engine.
- (6) If a speed drop occurs down to stand still of the main engine, it indicates that the engine may not be sufficiently powered for the intended service task. For consideration of loads, the maximum occurring torque during the speed drop process is to be applied. In such cases, excitation is to follow shaft speed.

Fig. 4.4.13-1 Example of the Excitation Torque due to Torsional Load for Different Blade Numbers ($Z=3$ and $Z=4$) in Polar Class $PC7$ ($H_{ice} = 1.5$)

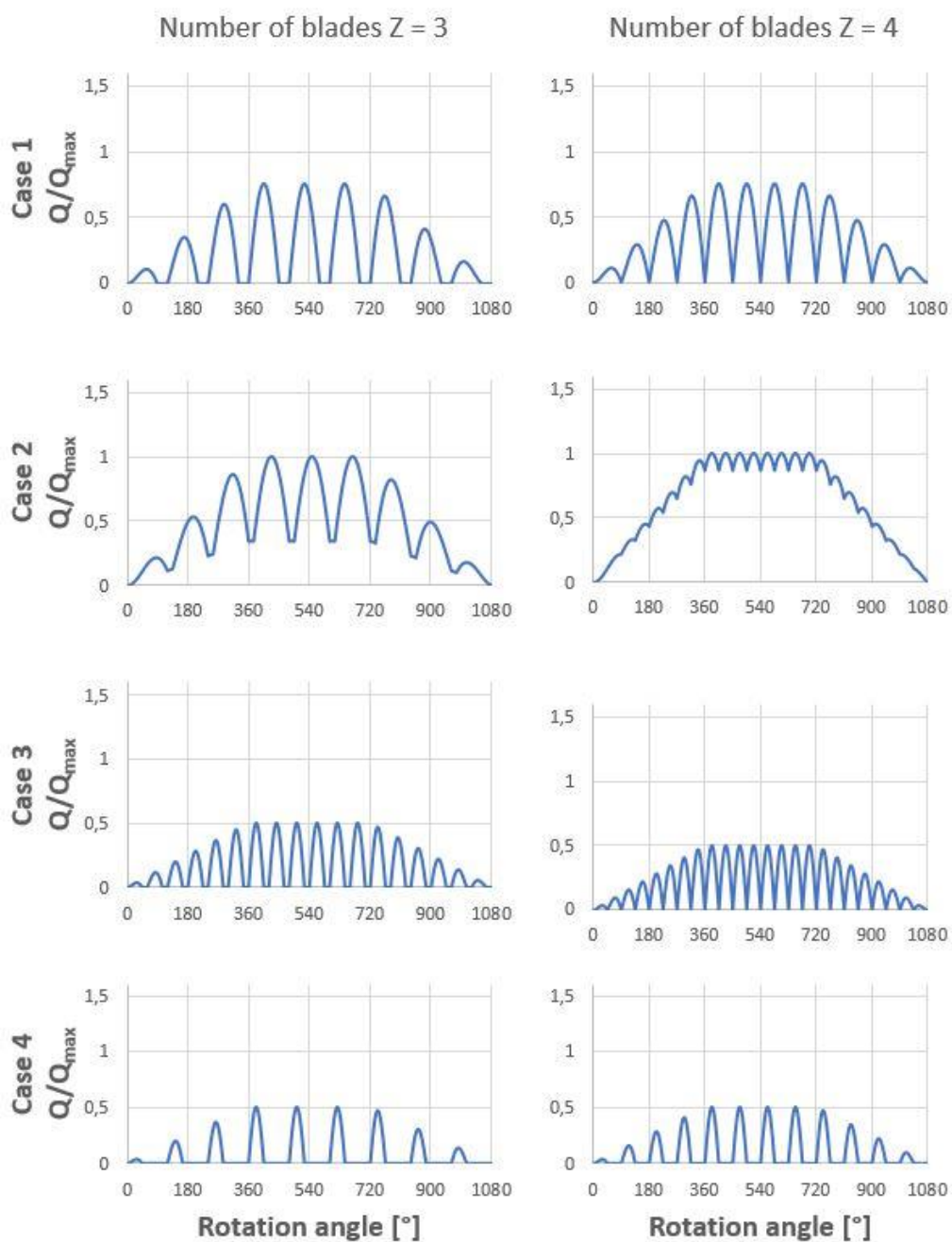
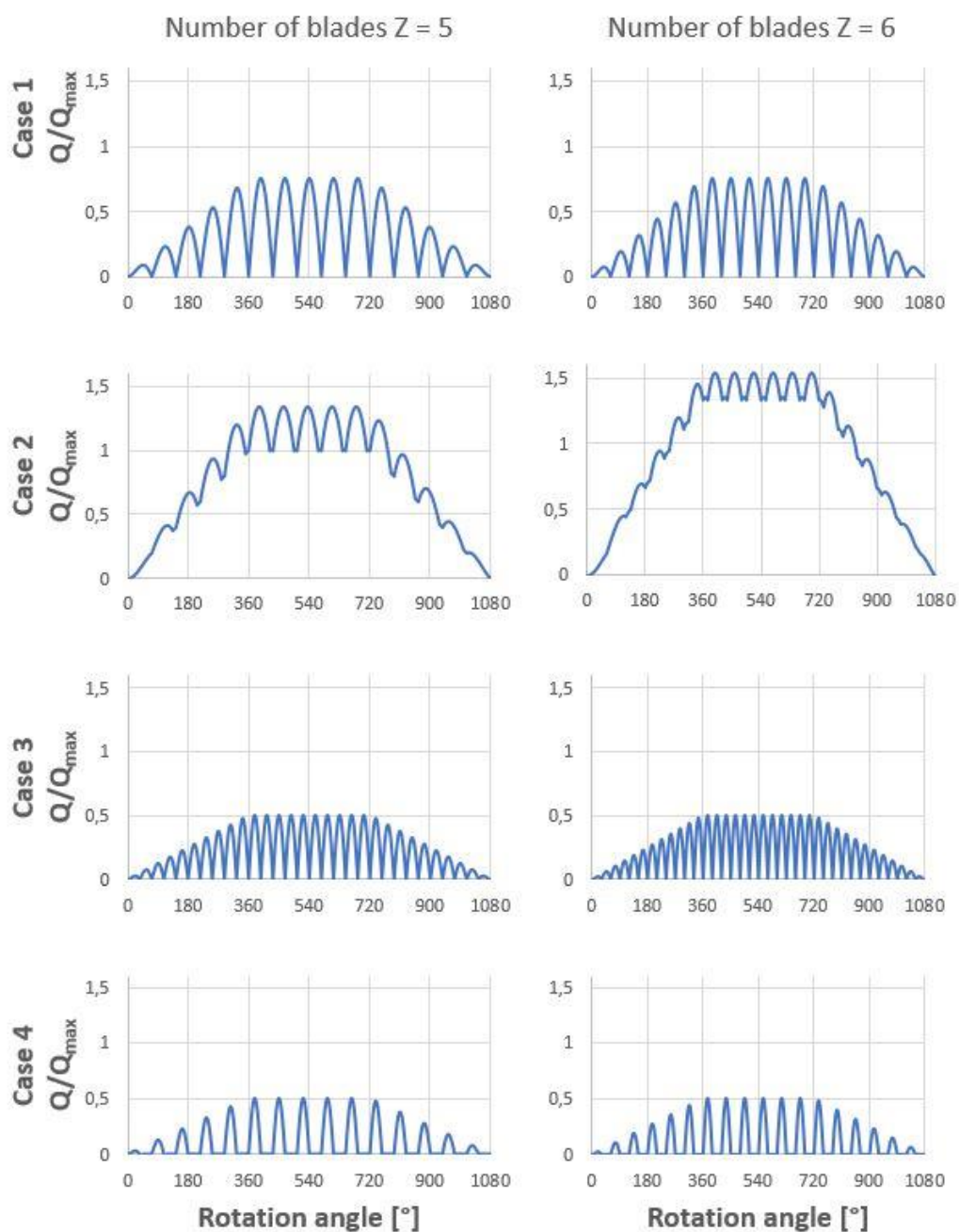

Fig. 4.4.13-2 Example of the Excitation Torque due to Torsional Load for Different Blade Numbers ($Z=5$ and $Z=6$) in Polar Class
 $PC7$ ($H_{ice} = 1.5$)

 Table 4.4.13-1 Values of C_q and a_i

Torque excitation	Propeller-ice interaction	C_q	a_i (deg)			
			Z=3	Z=4	Z=5	Z=6
Case 1	Single ice block	0.75	90	90	72	60
Case 2	Single ice block	1.0	135	135	135	135
Case 3	Two ice blocks (phase shift $360/(2 \cdot Z)$ deg)	0.5	45	45	36	30
Case 4	Single ice block	0.5	45	45	36	30

3 Frequency domain excitations

- (1) For frequency domain calculations, the torque excitation is to be given by following formula. The excitation has been derived so that the time domain half sine impact sequences have been assumed to be continuous and the Fourier series components for blade order and twice the blade order components have been derived. The frequency domain analysis is generally considered as conservative compared to the time domain simulation provided there is a first blade order resonance in the considered speed range:

$$Q_F(\varphi) = Q_{max}(C_{q0} + C_{q1}\sin(ZE_0\varphi + \alpha_1) + C_{q2}\sin(2ZE_0\varphi + \alpha_2)) \quad (kNm)$$

where

C_{q0} : Mean torque parameter, as specified in [Table 4.4.13-2](#)

C_{q1} : First blade order excitation parameter, as specified in [Table 4.4.13-2](#)

C_{q2} : Second blade order excitation parameter, as specified in [Table 4.4.13-2](#)

α_1, α_2 : Phase angles of the excitation component, as specified in [Table 4.4.13-2](#)

φ : Angle of rotation

E_0 : Number of ice blocks in contact, as specified in [Table 4.4.13-2](#)

Z : Number of propeller blades

- (2) Torsional vibration responses are to be calculated for all excitation cases.
- (3) The results of the relevant excitation cases at the most critical rotational speeds are to be used in the following. The highest response torque (between the various lumped masses in the system) is in the following referred to as peak torque Q_{peak} . The highest torque amplitude during a sequence of impacts is to be determined as half of the range from max to min torque and is referred to as Q_{Amax} . An illustration of Q_{Amax} is given in [Fig. 4.4.13-3](#). The highest torque amplitude is given by following formula:

$$Q_{Amax} = \left(\frac{\max(Q_r(time)) - \min(Q_r(time))}{2} \right) \quad (kNm)$$

Table 4.4.13-2 Values of C_{q0} , C_{q1} , α_1 , C_{q2} , α_2 , and E_0

Number of propeller blades: Z	Torque excitation	C_{q0}	C_{q1}	α_1	C_{q2}	α_2	E_0
3	Case 1	0.375	0.36	-90	0	0	1
	Case 2	0.7	0.33	-90	0.05	-45	1
	Case 3	0.25	0.25	-90	0		2
	Case 4	0.2	0.25	0	0.05	-90	1
4	Case 1	0.45	0.36	-90	0.06	-90	1
	Case 2	0.9375	0	-90	0.0625	-90	1
	Case 3	0.25	0.25	-90	0	0	2
	Case 4	0.2	0.25	0	0.05	-90	1
5	Case 1	0.45	0.36	-90	0.06	-90	1
	Case 2	1.19	0.17	-90	0.02	-90	1
	Case 3	0.3	0.25	-90	0.048	-90	2
	Case 4	0.2	0.25	0	0.05	-90	1
6	Case 1	0.45	0.36	-90	0.05	-90	1
	Case 2	1.435	0.1	-90	0	0	1
	Case 3	0.3	0.25	-90	0.048	-90	2
	Case 4	0.2	0.25	0	0.05	-90	1

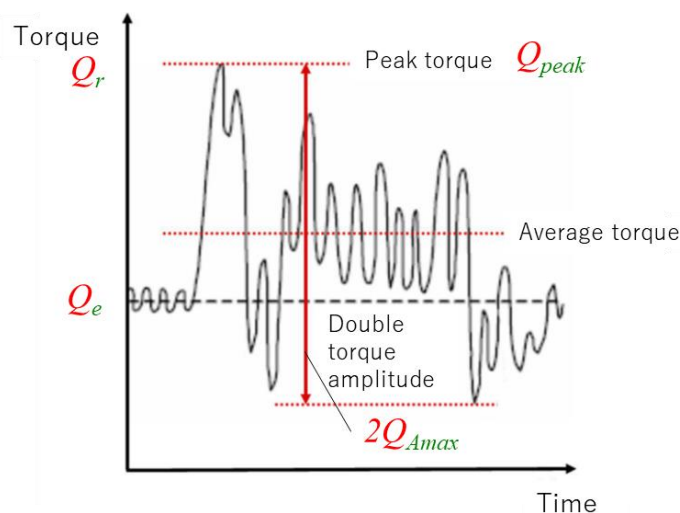
Fig. 4.4.13-3 Interpretation of Q_{Amax} in Torque Curve

4.4.14 Design Torque on Propulsion Shafting System

1 If there is not a predominant torsional resonance in the operational speed range or in the range 20 % above and 20 % below the maximum operating speed (bollard condition), the following estimation of the maximum torque can be used. All the torques and the inertia moments are to be reduced to the rotation speed of the component being examined:

Directly coupled two stroke diesel engines without flexible coupling

$$Q_{peak} = Q_{emax} + Q_{vib} + Q_{max} \frac{I}{I_t} \quad (kNm)$$

and other plants

$$Q_{peak} = Q_{emax} + Q_{max} \frac{I}{I_t} \quad (kNm)$$

where

Q_{peak} : Maximum response torque (kNm)

Q_{emax} : Maximum engine torque (kNm)

If the maximum torque, Q_{emax} , is not known, it is to be taken as specified in [Table 4.4.14-1](#)

Q_{vib} : Vibratory torque at considered component, taken from frequency domain open water torque vibration calculation (TVC)

I_e : Equivalent mass moment of inertia of all parts on the engine side of the component under consideration (kgm^2)

I_t : Equivalent mass moment of inertia of the entire propulsion system (kgm^2)

 Table 4.4.14-1 Maximum Engine Torque Q_{emax}

Propeller type	Q_{emax}
Propellers driven by electric motor	Q_{motor}
CP propellers not driven by electric motor	Q_n
FP propellers driven by turbine	Q_n
FP propellers driven by diesel engine	$0.75 Q_n$

Notes:

Q_{motor} : Electric motor peak torque (kNm)

Q_n : Nominal torque at maximum continuous revolutions in free running condition (kNm)

2 If there is a first blade order torsional resonance in the range 20 % above and 20 % below the maximum operating speed (bollard condition), the design torque of the shaft component is to be determined by means of a dynamic torsional vibration analysis of the entire propulsion line in the time domain or alternatively in the frequency domain. It is then assumed that the plant is sufficiently designed to avoid harmful operation in barred speed range.

4.4.15 Torsional Vibration Calculations

1 The aim of Torsional vibration calculations are used to estimate the torsional loads for individual shaft line components over the life time of the ship in order to determine scantlings for safe operation. The model can be taken from the normal lumped mass elastic torsional vibration model (frequency domain) including the damping. Standard harmonics may be used to consider the gas forces. The engine torque speed curve of the actual plant is to be applied.

2 For time domain analysis, the model is to include the ice excitation at the propeller, the mean torques provided by the prime mover and the hydrodynamic mean torque produced by the propeller as well as any other relevant excitations. The calculations are to cover the variation of phase between the ice excitation and prime mover excitation. This is extremely relevant for propulsion lines with direct driven combustion engines.

3 For frequency domain calculations the load is to be estimated as a Fourier component analysis of the continuous sequence of half sine load peaks. The first and second order blade components is to be used for excitation, and calculations are to cover the entire relevant shaft speed range. The analysis of the responses at the relevant torsional vibration resonances may be performed for open water (without ice excitation) and ice excitation separately. The resulting maximum torque can be obtained for directly coupled plants by the following superposition:

$$Q_{peak} = Q_{emax} + Q_{opw} + Q_{ice} \frac{I}{I_t} \text{ (kNm)}$$

where

Q_{emax} : Maximum engine torque at considered rotational speed (kNm)

Q_{opw} : Maximum open water response of engine excitation at considered shaft speed and determined by frequency domain analysis (kNm)

Q_{ice} : Calculated torque using frequency domain analysis for the relevant shaft speeds, ice excitation case 1 to case 4, resulting in the maximum response torque due to ice excitation (kNm)

4.5 Design

4.5.1 Design Principles

1 Propulsion lines are to be designed according to the pyramid strength principle. This means that the loss of a propeller blade is not to cause any significant damage to other propeller shaft line components.

2 Propulsion line components are to withstand maximum and fatigue operational loads with the relevant safety margin. The loads do not need to be considered for shaft alignment or other calculations of normal operational conditions such the torsional vibration of shafting specified in [Chapter 8, Part D of the Rules](#).

4.5.2 Fatigue Design in General

1 Design loads are to be based on ice excitation and where necessary (shafting) dynamic analysis, and described as a sequence of blade impacts ([4.4.13-2](#)). Shaft response torque is to be determined according to [4.4.14](#).

2 Propulsion line components are to be designed so as to prevent accumulated fatigue failure when considering the relevant loads using the linear elastic Miner's rule defined as follows:

$$D = \frac{n_1}{N_1} + \frac{n_2}{N_2} + \dots + \frac{n_k}{N_k} \leq 1$$

or

$$D = \sum_{j=1}^{j=k} \frac{n_j}{N_j} \leq 1$$

where

k : Number of stress level

$N_{l,k}$: Number of load cycles to failure of the individual stress level class

$n_{l,k}$: Accumulated number of load cycles of the case under consideration, per class

D : Sum of damage using Miner's rules

3 Stress distributions are to be divided into frequency load spectrums having a minimum ten stress blocks (every 10 % of the load) because calculations having five stress blocks have been found to be too conservative. In addition, maximum allowable loads are limited by σ_{ref2} for propeller blades and yield strength for all other components, and load distributions (spectrums) are to be in accordance with the Weibull distribution.

4.5.3 Propeller Blades

1 Calculations of blade stresses due to static loads are as follows:

- (1) Propeller blade stresses are to be calculated for the design loads given in 4.4.3 to 4.4.8 using Finite Element Analysis.
- (2) In the case of a relative radius $r/R < 0.5$, the blade stresses for all propellers at their root areas may be obtained by the following formula:

$$\sigma_{st} = C_1 \frac{M_{BL}}{100ct^2} \text{ (MPa)}$$

where

$$C_1: \frac{\text{stress obtained with FEM analysis result}}{\text{stress obtained with beam equation}}$$

If the actual value is not available, C_1 is to be taken as 1.6.

M_{BL} : Blade bending moment (kNm), but to be as follows in the case of a relative radius $r/R < 0.5$:

$$M_{BL} = (0.75 - r/R)RF$$

where

F : Force F_b or F_f , whichever has the greater absolute value.

- 2 The calculated blade stress σ_{st} specified in -1 above is to comply with the following:

$$\frac{\sigma_{ref2}}{\sigma_{st}} \geq 1.3$$

where

σ_{st} : Maximum stress resulting from F_b or F_f (MPa).

If Finite Element Analysis is used in estimating the stresses, von Mises stresses are to be used.

σ_{ref2} : Reference strength (MPa), whichever is less, as obtained by the following formulae:

$$\sigma_{ref2} = 0.7\sigma_u, \text{ or } \sigma_{ref2} = 0.6\sigma_{0.2} + 0.4\sigma_u$$

3 Fatigue design of propeller blades

- (1) General

- (a) For materials with two-slope S-N curves (See Fig. 4.5.3-1), the fatigue calculations specified in this section are not required if the following criterion is fulfilled.

$$\sigma_{exp} \geq B_1 \sigma_{ref2}^{B_2} \log(N_{ice})^{B_3}$$

where

σ_{exp} : Mean fatigue strength of the blade material at 10^8 cycles to failure in seawater (MPa), as given in Table 4.5.3-4

B_1, B_2 and B_3 : Coefficients, as given in Table 4.5.3-1

- (b) Where the criterion in (a) above is not fulfilled the fatigue requirements defined below apply:

- i) The fatigue design of a propeller blade is based on the estimated load distribution for the service life of the ship and the S-N curve for the blade material. An equivalent stress σ_{fat} that produces the same fatigue damage as the expected load distribution is to be calculated according to Miner's rule. An equivalent stress that produces the same fatigue damage as the expected load distribution is to be calculated and the acceptability criterion for fatigue is to be fulfilled as given in this paragraph. The equivalent stress is normalised for 10^8 cycles.

- ii) The blade stresses at various selected load levels for fatigue analysis are to be taken proportional to the stresses calculated for maximum loads given in 4.4.3 to 4.4.8. The peak principal stresses σ_f and σ_b are determined from F_f and F_b using Finite Element analysis. The peak stress range $\Delta\sigma_{max}$ and the maximum stress amplitude σ_{Amax} are respectively determined on the basis of load cases 1 and 3, and cases 2 and 4.

$$\Delta\sigma_{max} = 2\sigma_{Amax} = |(\sigma_{ice})_{fmax}| + |(\sigma_{ice})_{bmax}|$$

- iii) The load spectrum for backward loads is normally expected to have a lower number of cycles than the load spectrum for forward loads. Since taking this into account in a fatigue analysis introduces complications that are not justified considering all uncertainties involved, two types of S-N curves are to be used for calculations of equivalent stress.

- 1) Two-slope S-N curve (slopes 4.5 and 10) (See Fig. 4.5.3-1)

- 2) One-slope S-N curve (the slope can be chosen) (See Fig. 4.5.3-2)

- iv) S-N curve type is to be selected to correspond with the material properties of the blade. If the S-N curve is unknown, a two-slope S-N curve is to be used.

- (2) Equivalent fatigue stress

- (a) A more general method of determining the equivalent fatigue stress of propeller blades is described in 4.5.5, where the principal stresses are considered in accordance with 4.4.3 to 4.4.8 using the Miner's rule. For the total number of load blocks $nbl > 100$, both methods deliver the same result, therefore, are regarded as equivalent.
- (b) The equivalent fatigue stress for 10^8 cycles which produces the same fatigue damage as the load distribution is to be obtained as follows:

$$\sigma_{fat} = \rho(\sigma_{ice})_{max}$$

where

$$(\sigma_{ice})_{max} = 0.5((\sigma_{ice})_{fmax} - (\sigma_{ice})_{bmax})$$

$(\sigma_{ice})_{max}$: The mean value of the principal stress amplitudes resulting from design forward and backward blade forces at the location being studied. $(\sigma_{ice})_{fmax}$: The principal stress resulting from forward load

$(\sigma_{ice})_{bmax}$: The principal stress resulting from backward load

- (c) In the calculation of $(\sigma_{ice})_{max}$, case 1 and case 3, or case 2 and case 4 are to be considered as pairs for $(\sigma_{ice})_{fmax}$ and $(\sigma_{ice})_{bmax}$ calculations. Case 5 is excluded from the fatigue analysis.
- (d) The calculation of the parameter ρ for a two-slope S-N curve

- i) The range of the number of load cycles N_{ice} is to be given as follows. In such cases the error of the method in ii) to determine the parameter ρ is sufficiently small.

$$5 \times 10^6 \leq N_{ice} \leq 10^8$$

- ii) Parameter ρ relates the maximum ice load to the distribution of ice loads in accordance with the following regression formulae:

$$\rho = C_1(\sigma_{ice})_{max}^{C_2} \sigma_{fl}^{C_3} \log(N_{ice})^{C_4}$$

where

σ_{fl} : Characteristic fatigue strength for blade material for 10^8 load cycles(MPa) (See 4.5.3-3(3))

C_1, C_2, C_3 and C_4 : Coefficients, as given in Table 4.5.3-2

- (e) Calculations of the parameter ρ for constant-slope S-N curves

- i) In the case of materials with constant-slope S-N curves (See Fig. 4.5.3-2), the ρ parameter is to be obtained by the following formula:

$$\rho = \left(G \frac{N_{ice}}{N_R}\right)^{1/m} (\ln(N_{ice}))^{-1/k}$$

where

k : Shape parameter of the Weibull distribution to be taken as follows:

Ducted propellers: 1.0

Open propellers: 0.75

N_R : The reference number of load cycles ($= 10^8$)

m : slope for S-N curve in log/log scale

G : Values corresponding to m/k given in Table 4.5.3-3. Linear interpolation may be used to calculate the G value of m/k ratios other than those given in Table 4.5.3-3.

- (3) For the acceptance criterion for fatigue, the equivalent fatigue stresses at locations on blades area to satisfy the following acceptance criterion:

$$\frac{\sigma_{fl}}{\sigma_{fat}} \geq 1.5$$

where

σ_{fat} : Equivalent fatigue ice load stress amplitude for 10^8 stress cycles

σ_{fl} : Characteristic given by following formula:

$$\sigma_{fl} = \gamma_{\epsilon 1} \gamma_{\epsilon 2} \gamma_v \gamma_m \sigma_{exp}$$

$\gamma_{\epsilon 1}$: The reduction factor due to scatter (equal to one standard deviation)

$\gamma_{\epsilon 2}$: The reduction factor for test specimen size effect obtained by the following formula:

$$\gamma_{\epsilon 2} = 1 - a \cdot \ln\left(\frac{t}{0.025}\right)$$

where

a : The values given in Table 4.5.3-4

t : Maximum blade section thickness (m)

γ_v : The reduction factor for variable amplitude loading

γ_m : The reduction factor for mean stress obtained by the following formula:

$$\gamma_m = 1 - \left(\frac{1.4\sigma_{mean}}{\sigma_u} \right)^{0.75}$$

σ_{exp} : The mean fatigue strength of the blade material at 10^8 cycles to failure in seawater (MPa). The values in [Table 4.5.3-4](#) are to be used.

The following values are to be used as reduction factors if actual values are unavailable:

$$\gamma_{e1} = 0.67$$

$$\gamma_v = 0.75$$

$$\gamma_m = 0.75$$

Table 4.5.3-1 The Coefficients B_1 , B_2 and B_3

Coefficients	Open propeller	Ducted propeller
B_1	0.00328	0.00223
B_2	1.0076	1.0071
B_3	2.101	2.471

Fig. 4.5.3-1 Two-slope S-N Curve

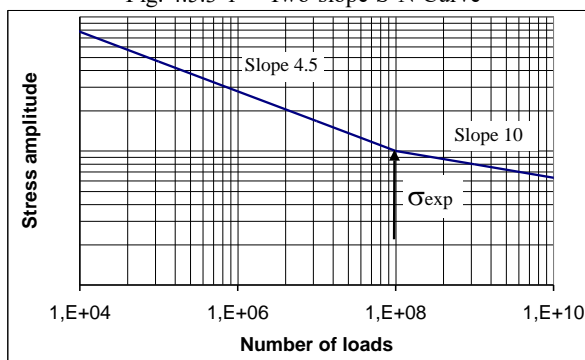

Fig. 4.5.3-2 Constant-slope S-N Curve

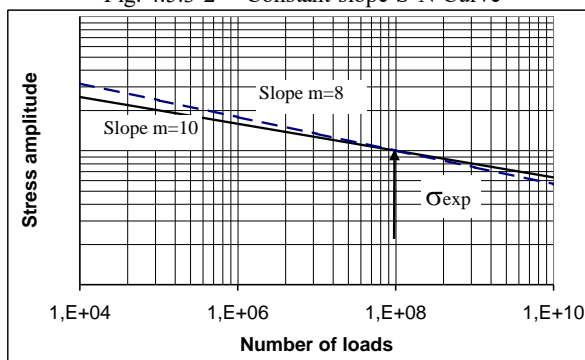

Table 4.5.3-2 The Coefficients C_1 , C_2 , C_3 and C_4

Coefficients	Open propeller	Ducted propeller
C_1	0.000747	0.000534
C_2	0.0645	0.0533
C_3	-0.0565	-0.0459
C_4	2.220	2.584

 Table 4.5.3-3 Value for the G Parameter for Different m/k Ratios

m/k	G	m/k	G	m/k	G	m/k	G
3	6	5.5	287.9	8	40320	10.5	11.899E6
3.5	11.6	6	720	8.5	119292	11	39.917E6
4	24	6.5	1871	9	362880	11.5	136.843E6
4.5	52.3	7	5040	9.5	1.133E6	12	479.002E6
5	120	7.5	14034	10	3.629E6		

 Table 4.5.3-4 Mean Fatigue Strength σ_{exp} for Different Material Types

Bronze and brass ($a = 0.01$)		Stainless steel ($a = 0.05$)	
<i>Mn</i> Bronze (<i>KHB</i> sC1)	84 MPa	Ferritic (12Cr-1Ni) (<i>KSCSP</i> 1)	144 MPa ⁽²⁾
<i>Mn-Ni</i> Bronze (<i>KHB</i> sC2)	84 MPa	Martensitic (13Cr-4Ni) (<i>KSCSP</i> 2)	156 MPa
<i>Ni-Al</i> Bronze (<i>KAIBC</i> 3)	120 MPa	Martensitic(16Cr-5Ni) (<i>KSCSP</i> 3)	168 MPa
<i>Mn-Al</i> Bronze (<i>KAIBC</i> 4)	113 MPa	Austenitic(19Cr-11Ni) (<i>KSCSP</i> 3)	132 MPa

Notes:

- (1) Values are defined from the results of constant amplitude loading fatigue tests at 10^7 load cycles and 50% survival probability and have been extended to 10^8 load cycles. Values other than those given in this table may be used, provided they are deemed appropriate by the Society. S-N curve characteristics are based on two slopes, the first slope 4.5 is from 1000 to 10^8 load cycles and the second slope 10 is above 10^8 load cycles. The maximum allowable stress for one or a low number of cycles is limited to the range in 4.5.3-2, fatigue strength σ_{fat} is the fatigue limit at 100 million load cycles.
- (2) This value may be used, provided perfect galvanic protection is active, otherwise a reduction of about 30 MPa is to be applied.

4.5.4 Blade Bolts, Propeller Hubs and CP Mechanisms

1 General

- (1) The blade bolts, CP mechanisms, propeller bosses, and fitting of propellers to propeller shafts are to be designed to withstand maximum static and fatigue design loads (as applicable) defined in 4.4.3 to 4.4.8 and 4.5.3, and safety factors are to be greater than follows unless otherwise stated.
 - (a) Safety factor against yielding: 1.5
 - (b) Safety factor against fatigue: 1.5
- (2) Safety factors for loads resulting from loss of propeller blades through plastic bending as defined in 4.4.9-1 are to be greater than 1.0 against yielding.
- (3) Provided that calculated stresses duly considering local stress concentrations are less than yield strength or a maximum of 70 %

of σ_u of the respective materials, detailed fatigue analysis is not required. In other cases, however, components are to be analysed for cumulative fatigue, and an approach similar to that used for shafting assessment may be applied (See 4.5.5).

2 Blade bolts

- (1) Blade bolts are to withstand the following bending moments considered around tangents on bolt pitch circles or other relevant axis for non-circular joints that are parallel to the root section considered:

$$M_{bolt} = SF_{ex} \left(0.8 \frac{D}{2} - r_{bolt} \right) \quad (kNm)$$

where

r_{bolt} : radius to the bolts plane

S : Safety factor, taken as 1.0

- (2) Blade bolt pre-tension is to be sufficient to avoid separation between mating surfaces when the maximum forward and backward ice loads defined in 4.4.3 to 4.4.8 (open and ducted propellers respectively) are applied. For conventional arrangements, the following formula is to be used:

$$d_{bb} = 41^z \sqrt{\frac{F_{ex}(0.8D-d) \cdot S \cdot \alpha}{\sigma_{0.2} Z_{bb} PCD}} \quad (mm)$$

where

α : Factor based on the following bolt tightening methods. Other factors, however, may be used in cases where the Society deems it appropriate.

Torque guided tightening: 1.6

Elongation guided: 1.3

Angle guided: 1.2

Other additional means: 1.1

d_{bb} : effective diameter of blade bolt in way of thread

Z_{bb} : Number of blade bolts

S : Safety factor, taken as 1.0

3 CP mechanisms

- (1) Separate means (e.g. dowel pins) are to be provided in order to withstand the spindle torque resulting from blade failure Q_{sex} (4.4.9) or ice interaction Q_{smax} (4.4.6), whichever is greater. In addition, other components of CP mechanisms are not to be damaged by the maximum spindle torques (Q_{sex} or Q_{smax}), and 1/3 of the spindle torque is to be assumed to be consumed by friction when not otherwise documented through further analysis.

- (2) Diameters of fitted pins d_{fp} between blades and blade carriers are to be obtained by the following formula:

$$d_{fp} = 66 \sqrt{\frac{(Q_s - Q_{fr})}{PCD \cdot Z_{pin} \cdot \sigma_{0.2}}} \quad (mm)$$

where

$$Q_s = \max(S \cdot Q_{smax}; S \cdot Q_{sex}) \quad (kNm)$$

S : Safety factor, taken as 1.3 for Q_{smax} and as 1.0 for Q_{sex}

Q_{fr} : Friction between connected surfaces, taken as $0.33Q_s$. Alternative Q_{fr} calculations in accordance with reaction forces due to F_{ex} or F_f and F_b , whichever is relevant, may be used by utilising a friction coefficient = 0.15. In addition, stresses in actuating pins are to be obtained by the following formula:

$$\sigma_{vMises} = \sqrt{\left(\frac{\left(\frac{F \cdot h_{pin}}{2} \right)}{\left(\frac{\pi}{32} \right)} \right)^2 + 3 \left(\frac{F}{4 \cdot d_{pin}^2} \right)^2} \quad (MPa)$$

where

$$F = \frac{Q_s - Q_{fr}}{l_m} \quad (kN)$$

l_m : Distance pitching centre of blade to axis of pin (m)

h_{pin} : Height of actuating pin (mm)

d_{pin} : Diameter of actuating pin (mm)

Q_{fr} : Friction torque in blade bearings acting on blade palms and caused by reaction forces due to F_{ex} , or F_f , F_b , whichever is relevant are to be taken as 1/3 of spindle torque Q_s

- (3) Blade failure spindle torque Q_{sex} is not to lead to any consequential damage, and fatigue strength is to be considered for parts

transmitting the spindle torque from blades to servo systems in consideration of the ice spindle torque acting on one blade. In addition, maximum amplitude Q_{smax} is to be obtained by the following formula:

$$Q_{smax} = \frac{Q_{sb} + Q_{sf}}{2} \quad (kNm)$$

where

Q_{sb} : Spindle torque due to $|F_b|$ (mm)

Q_{sf} : Spindle torque due to $|F_f|$ (mm)

4 Servo pressures

- (1) Design pressures for servo systems are to be taken as the pressures caused by Q_{smax} or Q_{sex} when not protected by relief valves on the hydraulic actuator side or reduced by relevant friction losses in bearings caused by the respective ice loads.
- (2) Design pressures are not to be less than relief valve set pressure.

4.5.5 Propulsion Line Components

1 General

- (1) The ultimate loads resulting from the total blade failure F_{ex} defined in 4.4.9 are to consist of combined axial and bending load components, wherever this is significant. In addition, the minimum safety factor against yielding is to be 1.0 for all shaft line components.
- (2) Shafts and shafting components (such as bearings, couplings and flanges) are to be designed to withstand operational propeller/ice interaction loads.
- (3) Obtained loads are not intended to be used for shaft alignment calculations, and cumulative fatigue calculations are to be conducted in accordance with Miner's rule. In addition, fatigue calculations are not necessary when maximum stress is below fatigue strength at 10^8 load cycles.
- (4) Torque and thrust amplitude distributions (spectrums) in propulsion lines are to be obtained by the following formula (Weibull exponent $k = 1.0$):

$$Q_A(N) = Q_{Amax} \left(1 - \frac{\log(N)}{\log(Z \cdot N_{ice})} \right)$$

where

ZN_{ice} : The number of load cycles in the load spectrum

- (5) The Weibull exponent to be considered is $k = 1.0$ for both open and ducted propeller torque and bending forces. Load distributions are accumulated load spectrums, and load spectrums are to be divided into a minimum of ten load blocks when using Miner's rules. The load spectrums used to count the number of cycles for 100 % load are to be the number of cycles above the next step (e.g. 90 % load) to ensure that calculations are on the conservative side, since calculated safety margins become more conservative as the number of stress blocks used decreases. An example of ice load distribution (spectrum) for shafting is shown in Fig. 4.5.5-2.
- (6) Load spectrums are to be divided into the number of load blocks (nbl) for the Miner's rules, the number of cycles for each load block is to be obtained by the following formula:

$$n_i = N_{ice} \left(1 - \frac{i}{nbl} \right)^k - \sum_{i=1}^{i-1} n_{i-1}$$

where

i : Single load block

nbl : Number of load blocks

Fig. 4.5.5-1 Cumulative Torque Distribution

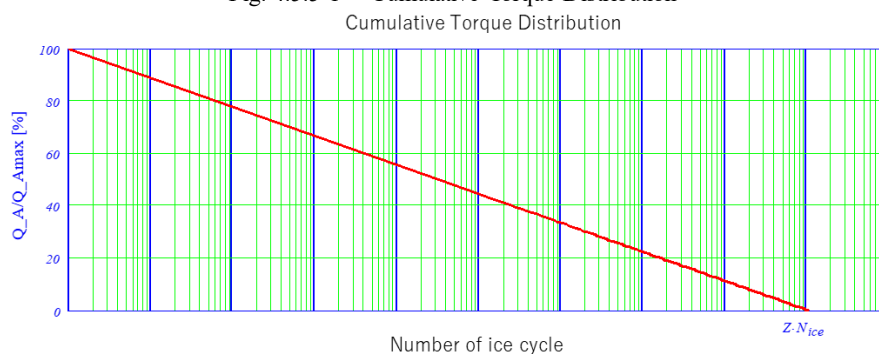
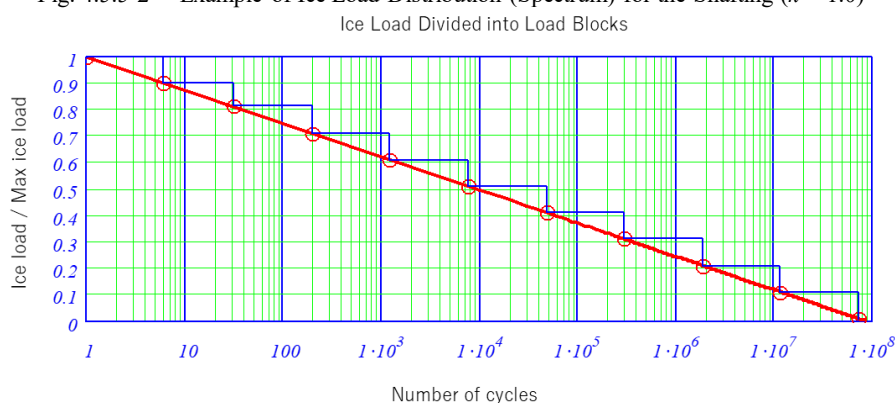
 Fig. 4.5.5-2 Example of Ice Load Distribution (Spectrum) for the Shafting ($k = 1.0$)

2 Fitting propellers to shafts

(1) Keyless cone mounting

- (a) Friction capacity at 0 °C is to be at least $S = 2.0$ times the highest peak torque Q_{peak} without exceeding the permissible hub stresses.
- (b) Necessary surface pressure $P_{0°C}$ is to be obtained by following formula:

$$P_{0°C} = \frac{2 \cdot S \cdot Q_{peak}}{\pi \cdot \mu \cdot D_s^2 \cdot L \cdot 10^3} \text{ (MPa)}$$

where

μ : Coefficient of friction between metal materials applicable only to this requirement and obtained as follows.

Coefficients are to be increased by 0.04 in cases where glycerin is used in wet mounting.

Steel and steel: 0.15

Steel and bronze: 0.13

D_s : Shrinkage diameter at the mid-length of the taper (m)

L : Effective length of taper (m)

S : Safety factor, more than 2.0

(2) Key mounting is not permitted.

(3) Flange mounting

- (a) Flange thickness is to be at least 25 % of the required aft end shaft diameter (See [6.2.4-1](#) and [-2, Part D of the Rules](#)).
- (b) Additional stress raisers such as recesses for bolt heads are not to interfere with flange fillets unless flange thickness is increased correspondingly.
- (c) Flange fillet radii are to be at least 10 % of the required shaft diameter.
- (d) The diameter of shear pins is to be obtained by the following formula:

$$d_{pin} = 66 \sqrt{\frac{Q_{peak} \cdot S}{P_{CD} \cdot z_{pin} \cdot \sigma_{0.2}}} \text{ (mm)}$$

where

d_{pin} : Diameter of shear pins (mm)

z_{pin} : Number of shear pins

S : Safety factor, taken as 1.3

- (e) Bolts are to be designed so that blade failure loads F_{ex} (4.4.9) in the backwards direction do not cause yielding of the bolts.

The following formula is to be used:

$$d_b = 41 \sqrt{\frac{F_{ex} \left(0.8 \frac{D}{PCD} + 1\right) \cdot \alpha}{\sigma_{0.2} \cdot z_b}} \quad (mm)$$

where

α : Factor based on the following bolt tightening methods. Other factors, however, may be used in cases where the Society deems it appropriate.

Torque guided tightening: 1.6

Elongation guided: 1.3

Angle guided: 1.2

Other additional means: 1.1

d_b : Diameter of flange bolt (mm)

Z_b : Number of flange bolts

3 Propeller shafts

- (1) Blade failure loads F_{ex}

- (a) Blade failure loads F_{ex} (4.4.9) applied parallel to shafts (forwards or backwards) are not to cause yielding, bending moments need not be combined with other loads. In addition, the diameter d_p in way of aft stern tube bearing are not to be less than the value of the following formula:

$$d_p = 160^3 \sqrt{\frac{F_{ex} \cdot D}{\sigma_{0.2} \left(1 - \frac{d_i^4}{d_p^4}\right)}} \quad (mm)$$

where

d_b : Propeller shaft diameter (mm)

d_i : Propeller shaft inner diameter (mm)

- (b) Forward of aft stern tube bearings, shaft diameters may be reduced based on direct calculation of the actual bending moment, or on the assumption that the bending moments caused by F_{ex} are linearly reduced to 25 % at the next bearing and in front of this linearly to zero at the third bearing.
- (c) Bending due to maximum blade forces F_b and F_f has been disregarded since the resulting stress levels are much lower than the stresses caused by the blade failure load.

- (2) Peak torque Q_{peak}

- (a) Stresses due to the peak torque Q_{peak} are to have minimum safety factors of $S = 1.5$ against yielding in plain sections and $S = 1.0$ in way of stress concentrations in order to avoid bent shafts.
- (b) Minimum shaft diameters are to be obtained by the following formula. Notched shaft diameters, however, are not to be less than required plain shaft diameters.

Plain shaft

$$d_p = 210^3 \sqrt{\frac{Q_{peak} \cdot S}{\sigma_{0.2} \left(1 - \frac{d_i^4}{d_p^4}\right)}} \quad (mm)$$

Notched shaft

$$d_p = 210^3 \sqrt{\frac{Q_{peak} \cdot S \cdot \alpha_t}{\sigma_{0.2} \left(1 - \frac{d_i^4}{d_p^4}\right)}} \quad (mm)$$

where

α_t : Local stress concentration factor in torsion

- (3) Torque amplitudes (See 4.4.13) of a corresponding number of load cycles are to be used in accumulated fatigue evaluation in which the safety factor is $S_{fat} = 1.5$. This is also to be considered when plants have high engine excited torsional vibrations (e.g. direct coupled 2-stroke engines).
- (4) Fatigue strength

- (a) The fatigue strengths σ_F and τ_F (three million cycles) of shaft materials may be assessed by the following formula on the basis of the material's yield or 0.2 % proof strength:

$$\sigma_F = 0.436 \cdot \sigma_{0.2} + 77 = \tau_F \cdot \sqrt{3} \text{ (MPa)}$$

This is valid for small polished specimens (no notch) and reversed stresses. (See "VDEH 1983 Bericht Nr. ABF11 Berechnung von Wöhlerlinien für Bauteile aus Stahl")

- (b) High cycle fatigue (*HCF*) is to be assessed based on the fatigue strengths in (a) above, notch factors (i.e. geometrical stress concentration factors and notch sensitivity), size factors, mean stress influence and at required safety factor of 1.6 at three million cycles increasing to 1.8 at 10^9 cycles.
- (c) Low cycle fatigue (*LCF*) representing 10^4 cycles is to be based on the smaller of yield or 0.7 of tensile strength $/\sqrt{3}$, and this criterion utilises a safety factor of 1.25.
- (d) The *LCF* and *HCF* given in (b) and (c) above represent the upper and lower knees in a stress-cycle diagram. Since the required safety factors are included in these values, a Miner's sum of unity is acceptable.

4 Intermediate shafts are to be designed to satisfy -3(2) to (4) above.

5 Shaft connections

- (1) Shrink fit couplings (keyless) are to be in accordance with 4.5.5-2(1). In such cases, a safety factor of 1.8 is to be used.
- (2) Key mounting is not permitted.
- (3) Flange mounting
- (a) Flange thickness is to be at least 20 % of the required shaft diameter (See 6.2.4-1 and -2, Part D of the Rules).
- (b) Additional stress raisers such as recesses for bolt heads are not to interfere with flange fillets unless flange thickness is increased correspondingly.
- (c) Flange fillet radii are to be at least 8 % of shaft diameters.
- (d) Diameters of ream fitted (i.e. light press fit) bolts are to be chosen so that peak torque is transmitted with a safety factor of 1.9 in consideration of prestress.
- (e) Pins are to transmit the peak torque with a safety factor of 1.5 against yielding (See -2(3)(d)).
- (f) Bolts are to be designed so that blade failure loads F_{ex} (4.4.9) in the backwards direction do not cause yielding.
- (4) Splined shaft connections may be applied in cases where no axial or bending loads occur. In such cases, a safety factor of $S = 1.5$ against the allowable contact and shear stresses resulting from Q_{peak} is to be applied.

6 Gear transmissions

- (1) Shafts in gear transmissions are to satisfy the same safety levels as intermediate shafts, but bending stresses and torsional stresses are to be combined (e.g. by von Mises for static loads) where relevant. Maximum permissible deflection in order to maintain sufficient tooth contact pattern is to be considered for the relevant parts of the gear shafts.
- (2) Gearing
- (a) The gearing is to satisfy the following three acceptance criteria:
- i) Tooth root stress
 - ii) Pitting of tooth flanks
 - iii) Scuffing
- (b) In addition to (a) above, criteria subsurface fatigue is to be considered, if necessary.
- (c) Common for all criteria is the influence of load distribution over face width. All relevant parameters such as elastic deflections (e.g. of mesh, shafts and gear bodies), accuracy tolerances, helix modifications, and working positions in bearings (especially for multiple input single output gears) are to be considered.
- (d) Load spectrums (See -1 above) are to be applied in such a way that the number of load cycles for output wheels are multiplied by a factor equaling the number of pinions on the wheel divided by number of propeller blades Z . For pinions and wheels operating at higher speeds, the number of load cycles is found by multiplication with the gear ratios. In addition, peak torque Q_{peak} is also to be considered during such calculations.
- (e) Cylindrical gears are to be assessed on the basis of the ISO 6336 series (i.e. ISO 6336-1:2019, ISO 6336-2:2019, ISO 6336-3:2019, ISO 6336-4:2019, ISO 6336-5:2016 and ISO 6336-6:2019), provided that "Method B" is used. Annex 5.3.1, Part D of the Rules may be applied provided that it is deemed equivalent by the Society.
- (f) The methods and standards applied to bevel gears are to be specially considered by the Society.

- (g) Tooth root safety is to be assessed against peak torque, torque amplitudes (with the pertinent average torque) and ordinary loads (open water free running) by means of accumulated fatigue analyses. The resulting safety factors are to be at least 1.5.
- (h) Safety against pitting is to be assessed in the same way as tooth root stresses but with a minimum resulting safety factor of 1.2.
- (i) Scuffing safety (flash temperature method – ref. *ISO/TR 13989-1:2000* and *ISO/TR 13989-2:2000*) based on peak torque is to be at least 1.2 when the FZG class of oil is assumed one stage below specification.
- (j) Safety against subsurface fatigue of flanks for surface hardened gears (oblique fractures from active flank to opposite roots) is to be at the discretion of the Society. (It is, however, to be noted that high overloads can initiate subsurface fatigue cracks that may lead to a premature failure.)
- (3) Bearings are to be in accordance with **-10** below.
- (4) Torque capacity is to be at least 1.8 times the highest peak torque Q_{peak} (at the rotational speed) without exceeding the permissible hub stresses of 80 % yield.

7 Clutches

- (1) Clutches are to have a static friction torque of at least 1.3 times the peak torque Q_{peak} and a dynamic friction torque 2/3 of the static friction torque.
- (2) Emergency operation of clutches after failure of operating pressure is to be made possible within a reasonably short time. If this is arranged by bolts, it is to be on the engine side of the clutch in order to ensure access to all bolts by turning the engine.

8 Elastic couplings

- (1) There is to be a separation margin of at least 20 % between the peak torque and the torque where any twist limitation is reached.
 $Q_{peak} < 0.8T_{Kmax}(N = 1)$ (kNm)
- (2) There is to be a separation margin of at least 20 % between the maximum response torque Q_{peak} (See **Fig. 4.4.13-3**) and the torque where any mechanical twist limitation or the permissible maximum torque of the elastic coupling, valid for at least a single load cycle ($N = 1$), is reached.
- (3) Sufficient fatigue strength is to be demonstrated at design torque level $Q_r(N=x)$ and $Q_A(N=x)$. This may be demonstrated by interpolation in a Weibull torque distribution (similar to **Fig. 4.5.5-1**) by the following formulae:

$$\frac{Q_r(N=x)}{Q_r(N=1)} = 1 - \frac{\log(x)}{\log(Z \cdot N_{ice})}$$

$$\frac{Q_A(N=x)}{Q_A(N=1)} = 1 - \frac{\log(x)}{\log(Z \cdot N_{ice})}$$

where

$Q_r(N=1)$ corresponds to Q_{peak} and $Q_A(N=1)$ corresponds to Q_{Amax} .

$$Q_r(N = 5E4) \cdot S < T_{Kmax}(N = 5E4) \text{ (kNm)}$$

$$Q_r(N = 1E6) \cdot S < T_{KV} \text{ (kNm)}$$

$$Q_A(N = 5E4) \cdot S < \Delta T_{max}(N = 5E4) \text{ (kNm)}$$

where

S: General safety factor for fatigue, taken as 1.5

- (4) Torque amplitude (or range Δ) is not to lead to fatigue cracking (i.e. not to exceed permissible vibratory torque). Permissible torque is to be determined by interpolation using a Weibull torque distribution in which T_{Kmax1} respectively ΔT_{max} refers to 50000 cycles and T_{KV} refers to 10^6 cycles (See **Fig. 4.5.5-3**)

$$T_{Kmax1} \geq Q_r (5 \times 10^4 \text{ load cycles}) \text{ (kNm)}$$

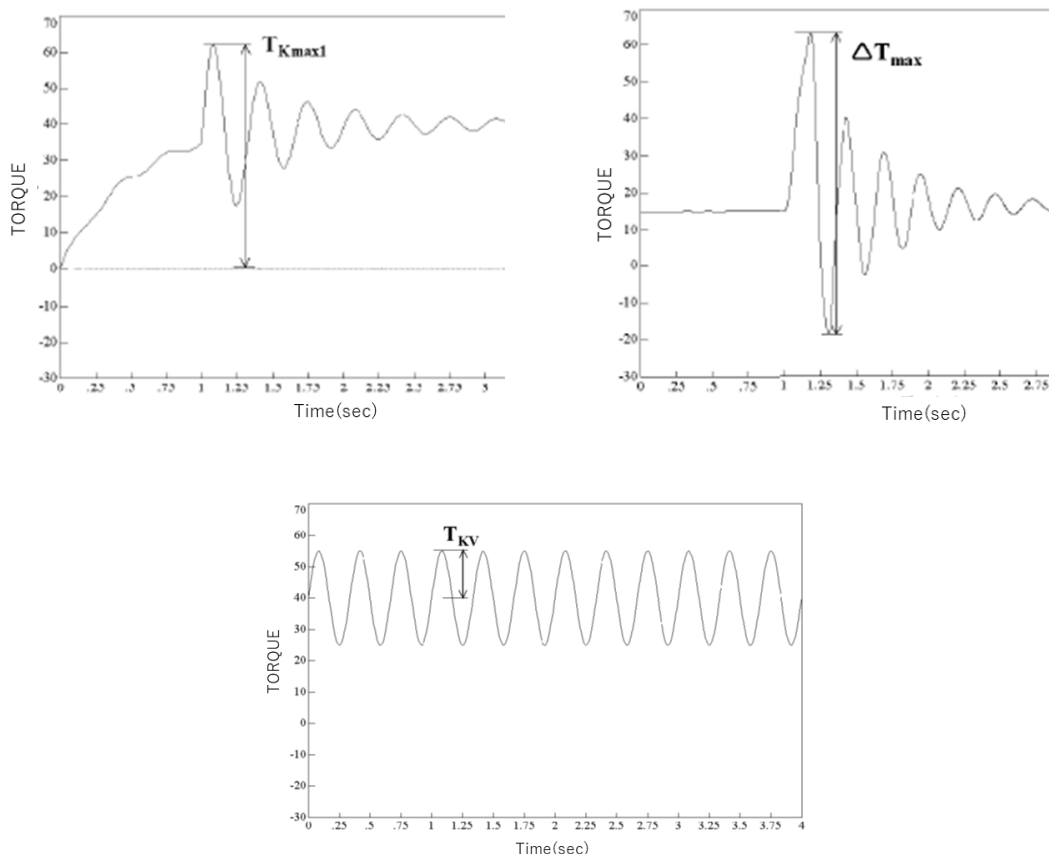
Fig. 4.5.5-3 Example of TK_{maxI} , ΔT_{max} and TKV

9 Crankshafts

Special consideration is to be given to plants with large inertia (e.g. flywheels, tuning wheels or PTO) in the non-driving end fronts of engines (opposite to main power take off).

10 Bearings

- (1) Aft stern tube bearings and next shaft line bearings are to withstand the F_{ex} given in 4.4.9 in such a way that allows ships to maintain operational capability.
- (2) Rolling bearings are to have L_{10a} lifetimes of at least 40,000 hours according to ISO 281:2007.
- (3) Thrust bearings and their housings are to be designed to withstand with a safety factor $S = 1.0$ the maximum response thrusts in 4.4.11 and the axial forces resulting from the blade failure load F_{ex} in 4.4.9. For the purpose of calculation, except for F_{ex} , shafts are assumed to rotate at rated speed. For pulling propellers, special consideration is to be given to loads from ice interaction on propeller hubs.

11 Seals

- (1) Seals are to prevent egress of pollutants and be suitable for operating temperatures. In addition, contingency plans for preventing the egress of pollutants under failure conditions are to be documented.
- (2) Seals installed are to be suitable for the intended application. Manufacturers are to provide service experience in similar applications or testing results for consideration.

4.5.6 Azimuthing Main Propulsors

In the design of the azimuthing main propulsors, the following are to be taken into account in addition to the requirements specified in 4.5.5.

- (1) Loading cases which are extraordinary for propulsion units are to be taken into account. Estimation of the loading cases is to reflect the operational realities of the ship and the thrusters (for example, loads caused by the impact of ice blocks on propeller hubs of pulling propellers). Furthermore, loads resulting from thrusters operating at oblique angles to the flow are to be

considered.

- (2) The steering mechanism, the fitting of the unit and body of the thruster are to be designed to withstand the loss of a blade without damage.
- (3) The loss of a blade is to be considered in the propeller blade position, which causes the maximum load on the studied component. Typically, a top-down blade orientation leads to maximum bending loads acting on thruster bodies.
- (4) Azimuth thrusters are to be designed for estimated loads caused by thruster body/ice interaction, and the thruster bodies are to withstand the loads obtained when the maximum ice blocks given in 4.4.2 strike the thruster body when ships are at typical ice operating speed. In addition, the design situation in which ice sheets glide along ship hulls and presses against thruster bodies is to be considered in which sheet thicknesses are taken as the thickness of the maximum ice block entering the propeller, as defined in section 4.4.2.

4.6 Prime Movers

4.6.1 Main Engines

- 1 Main engines are to be capable of being started and running propellers in the bollard condition.
- 2 Main engines are to be capable of being started and running the propeller with the controllable pitch in full pitch as limited by mechanical stoppers.

4.6.2 Starting Arrangements

- 1 The capacities of air receivers are to be sufficient to provide, without recharging, not less than 12 consecutive starts of propulsion engines, and not less than 6 consecutive starts when reversed for going astern in cases where propulsion engines do not need to be reversed for going astern. Air receivers serving other purposes in addition to starting propulsion engines are to have additional capacities sufficient for such purposes.
- 2 The capacities of air compressors are to be sufficient for charging air receivers from atmospheric to full pressure in 1 hour, except for ice class PC6 to PC1 ships for which propulsion engines need to be reversed for going astern. In such cases, compressors are to be able to charge receivers within 30 minutes.

4.6.3 Emergency Generating Sets

- 1 Provisions are to be made for heating arrangements to ensure the ready starting of emergency power units from a cold state at an ambient temperature applicable to the polar class ship.
- 2 Emergency power units are to be equipped with starting devices with stored energy capabilities of at least three consecutive starts at the temperatures specified in -1 above, and sources of stored energy are to be protected to preclude critical depletion by automatic starting systems, unless a second independent mean of starting is provided. In addition, a second source of energy is to be provided for an additional three starts within 30 minutes, unless manual starting can be demonstrated to be effective.

4.7 Fastening Loading Accelerations

4.7.1 Machinery Fastening Loading Accelerations

Supports of essential equipment and main propulsion machinery are to be suitable for the accelerations given by the following formulae. Accelerations are to be considered as acting independently.

- (1) Maximum longitudinal impact acceleration at any point along the hull girder:

$$a_l = \left(\frac{F_{IB}}{\Delta}\right) \left\{ [1.1 \tan(\gamma + \phi)] + \left[\frac{7H}{L}\right] \right\} (m/s^2)$$

- (2) Combined vertical impact acceleration at any point along the hull girder:

$$a_v = 2.5 \left(\frac{F_{IB}}{\Delta}\right) F_X (m/s^2)$$

where

$$F_X = 1.3 \text{ (at fore perpendicular)}$$

$$= 0.2 \text{ (at midships)}$$

$$= 0.4 \text{ (at aft perpendicular)}$$

$$= 1.3 \text{ (at aft perpendicular for vessels conducting ice breaking astern)}$$

Intermediate values to be interpolated linearly.

- (3) Combined transverse impact acceleration at any point along hull girder:

$$a_t = 3F_i \frac{F_X}{\Delta} \quad (m/s^2)$$

where

$$F_X = 1.5 \text{ (at fore perpendicular)}$$

$$= 0.25 \text{ (at midships)}$$

$$= 0.5 \text{ (at aft perpendicular)}$$

$$= 1.5 \text{ (at aft perpendicular for vessels conducting ice breaking astern)}$$

Intermediate values to be interpolated linearly.

where

ϕ : Maximum friction angle (*deg*) between steel and ice, normally taken as 10 degrees

γ : Bow stem angle (*deg*) at the *UIWL*

Δ : Displacement at the *UIWL* (*t*)

L : Length of ship (*m*) defined in **2.1.2, Part A of the Rules**

H : Distance (*m*) from the *UIWL* to the point being considered

F_{IB} : Vertical impact force (*kN*) defined in **3.5.2**

F_i : Force (*kN*) defined in **3.3.1-1(3)(b)**

4.8 Auxiliary Systems and Piping Systems

4.8.1 Auxiliary Systems

- 1 Machinery is to be protected from the harmful effects of ingestion or accumulation of ice or snow. Where continuous operation is necessary, means are to be provided to purge the system of accumulated ice or snow.
- 2 Means are to be provided to prevent tanks containing liquids to be damaged by freezing.
- 3 Vent pipes, intake and discharge pipes and associated systems are to be designed to prevent blockage due to freezing or ice and snow accumulation.

4.8.2 Sea Inlets and Cooling Water Systems

- 1 Cooling water systems for machinery that are essential for the propulsion and safety of the vessel, including sea chests inlets are to be designed for the environmental conditions applicable to the polar class.
- 2 The construction of the sea chests is to comply with the following requirements:
 - (1) At least two sea chests are to be arranged as ice boxes for *PC1*, *PC2*, *PC3*, *PC4* and *PC5* polar class ships.
 - (2) At least one ice box is to be arranged preferably near the centerline for *PC6* and *PC7* polar class ships.
 - (3) The calculated volume for each of the ice boxes is to be at least $1m^3$ for every $750kW$ of the engine output of the ship including the output of auxiliary engines.
 - (4) Ice boxes are to be designed for an effective separation of ice and venting of air. (See example of **Fig. 4.8.2-1**)
- 3 Sea inlet valves are to be secured directly to the ice boxes or the sea bays. The valve is to be a full bore type.
- 4 Ice boxes and sea bays are to have vent pipes and to have shut off valves connected direct to the shell.
- 5 Means are to be provided to prevent freezing of sea bays, ice boxes, ship side valves and fittings above the *LIWL*.
- 6 Efficient means are to be provided to re-circulate cooling seawater to the ice box. Total sectional area of the circulating pipes is not to be less than the area of the cooling water discharge pipe.
- 7 Detachable gratings or manholes are to be provided for ice boxes. Manholes are to be located above the *UIWL*.
- 8 Openings in ship sides for ice boxes are to be fitted with gratings, or holes or slots in shell plates. The net area through these openings is to be not less than 5 times the area of the inlet pipe. The diameter of holes and width of the slot in shell plating is to be not less than $20mm$.
- 9 Gratings of the ice boxes are to be provided with a means of cleaning with a low pressure steam connection. Cleaning pipes are to be provided with screw-down type non return valves.

Fig. 4.8.2-1 Example of the Sea Inlets and Cooling Water Systems

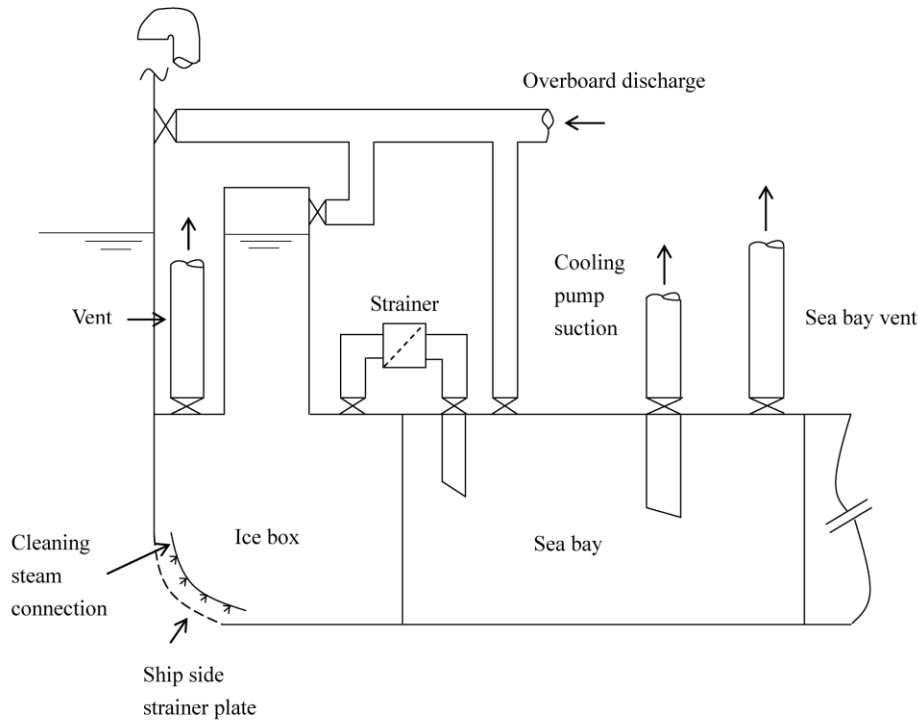

4.8.3 Ballast Tanks

Efficient means are to be provided to prevent freezing in fore and after peak tanks and wing tanks located above the *LIWL* and where otherwise found necessary.

4.9 Ventilation System

4.9.1 Ventilation System

1 The air intakes for machinery and accommodation ventilation are to be located on both sides of the ship at locations where manual de-icing is possible.

2 The air intakes specified in -1 above may be provided with a means equivalent to the manual de-icing required in -1 above when deemed appropriate by the Society.

3 Multiple air intakes are to be provided for emergency generating sets, and such intakes are to be as far apart as possible.

4 Temperature of inlet air is to be suitable for the following purposes. In addition, accommodation and ventilation air inlets are, if necessary, to be provided with means of heating.

- (1) Safe operation of machinery
- (2) Thermal comfort in accommodation spaces

4.10 Rudders and Steering Arrangements

4.10.1 Rudders and Steering Arrangements

1 An ice knife is to be fitted to protect the rudder in the centre position against ice pressure. The ice knife is to be extended below the *LIWL*.

2 Rudder stops to protect steering arrangements are to be provided, and the design ice force acting on rudders is to be transmitted to said rudder stops without damaging steering systems.

3 The components of the steering gear are to be dimensioned to stand the yield torque of the rudder stock.

4 Relief valves for hydraulic pressure of the steering arrangements are to be effective.

4.10.2 Rudder Actuators

1 Rudder actuators are to be designed for holding torque obtained by multiplying the open water torque specified in 15.2.2(1), Part D of the Rules (in consideration of a maximum speed of 18 knots) by the factors specified in Table 4.10.2-1.

2 Design pressures for calculations to determine the scantlings of rudder actuators are to be at least 1.25 times the maximum working pressure corresponding to the holding torque defined in -1 above.

3 Rudder actuators are to be protected by torque relief arrangements, assuming the turning speeds (*deg/s*) specified in Table 4.10.2-2 without undue pressure rise. If, however, rudder and actuator designs can withstand such rapid loads, such special relief arrangements are not necessary and conventional ones may be used instead.

4 For ship affixed with the additional notation “Icebreaker” (abbreviated to *ICB*), fast-acting torque relief arrangements are to be fitted in order to provide effective protection of rudder actuators in case where rudders are rapidly forced hard over against the stops.

5 For hydraulically operated steering gear, fast-acting torque relief arrangements are to be so designed that pressures cannot exceed 115 % of the set pressures of safety valves when rudders are forced to move at the speeds indicated in Table 4.10.2-3, and when taking into account oil viscosity at the lowest expected ambient temperatures in steering gear compartments.

6 For alternative steering systems, fast-acting torque relief arrangements are to demonstrate degrees of protection equivalent to that required for hydraulically operated arrangements.

7 Arrangements are to be designed such that steering capacity can be speedily regained.

Table 4.10.2-1 Factors for Holding Torque

	PC1 and PC2	PC3 to PC5	PC6 and PC7
Factor	5	3	1.5

Table 4.10.2-2 Turning Speeds of Steering Gear (Torque relief arrangements)

	PC1 and PC2	PC3 to PC5	PC6 and PC7
Turning speeds (<i>deg/s</i>)	10	7.5	6

Table 4.10.2-3 Turning Speeds of Steering Gear (Fast-acting torque relief arrangement)

	PC1 and PC2	PC3 to PC5	PC6 and PC7
Turning speeds (<i>deg/s</i>)	40	20	15

4.11 Alternative Design

4.11.1 Alternative Design

As an alternative to this chapter, a comprehensive design study may be submitted and may be requested to be validated by an agreed test programme.

Contents

GUIDANCE FOR THE SURVEY AND CONSTRUCTION OF STEEL SHIPS	2
Part I SHIPS OPERATING IN POLAR WATERS, POLAR CLASS SHIPS AND ICE CLASS SHIPS .	2
I1 GENERAL APPLICATION	2
I1.1 General.....	2
I1.2 Definitions	2
I1.3 Performance Standards (<i>Polar Code</i> , Part I-B, 2.3).....	3
I1.5 Operational Assessment (<i>Polar Code</i> , Part I-B, 2.1, 2.2)	3
I2 POLAR WATER OPERATIONAL MANUAL (PWOM).....	5
I2.3 Regulations.....	5
I3 SHIP STRUCTURE.....	6
I3.3 Regulations (with reference to <i>Polar Code</i> , Part I-B, 4).....	6
I6 MACHINERY INSTALLATIONS	7
I6.3 Regulations (Related to <i>Polar Code</i> , Part I-B, 7).....	7
I7 FIRE SAFETY/PROTECTION	8
I7.3 Regulations.....	8
I8 ICE CLASS SHIPS	9
I8.1 General.....	9
I8.3 Hull Structures and Equipment	9
I8.4 Fundamental Requirements of Machinery	13
I8.6 Design of Propellers and Propulsion Shafting Systems (Ice Classes <i>IA Super</i> , <i>IA</i> , <i>IB</i> and <i>IC</i>) 14	
I8.7 Alternative Designs	14

GUIDANCE FOR THE SURVEY AND CONSTRUCTION OF STEEL SHIPS**Part I SHIPS OPERATING IN POLAR WATERS, POLAR CLASS SHIPS
AND ICE CLASS SHIPS****11 GENERAL APPLICATION****11.1 General****11.1.2 Documentation**

1 With respect to the provisions of 1.1.2-1 and 1.1.2-2, Part I of the Rules, draughts at fore, midship and aft corresponding to the upper ice waterline and the lower ice waterline are to be indicated in the Certificate of Classification for a polar class ship.

2 With respect to the provisions of 1.1.2-1 and 1.1.2-3, Part I of the Rules, draughts at fore, midship and aft corresponding to the upper ice waterline and the lower ice waterline are to be indicated in the Certificate of Classification for an ice class ship.

11.2 Definitions**11.2.1 Terms**

“Mean Daily Low Temperature” (*MDLT*) as specified in 1.2.1(19), Part I of the Rules is to refer to Fig. 11.2.1-1.

Fig. 11.2.1-1 Mean Daily Low Temperature

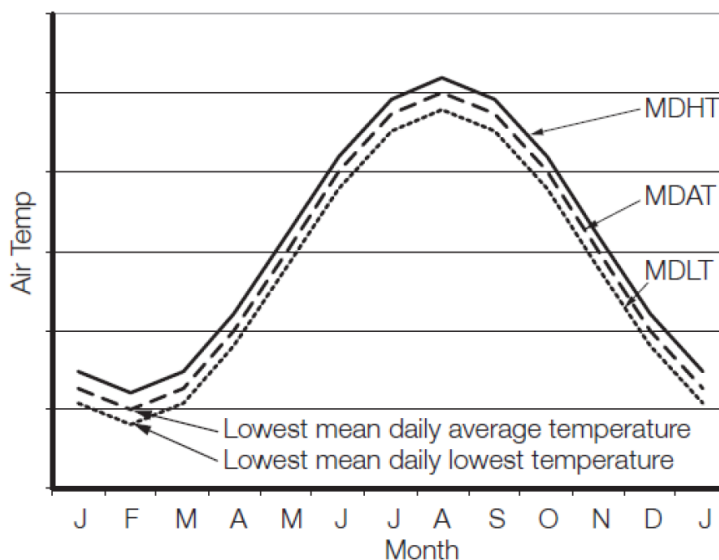

(Notes)

1. Terms used in the figure above are as follows:
 - MDHT* – Mean Daily High Temperature
 - MDAT* – Mean Daily Average Temperature
 - MDLT* – Mean Daily Low Temperature
2. *MDLT* is determined as follows:
 - (1) Determine the daily low temperature for each day for a 10 year period.
 - (2) Determine the average of the values over the 10 year period for each day.

- (3) Plot the daily averages over the year.
- (4) Take the lowest of the averages for the season of operation.

11.2.2 Ice Class Ships

1 The correspondence of ice classes specified in **1.2.2, Part I of the Rules** with those in the *Finnish-Swedish Ice Class Rules* is as given in **Table 11.2.2-1**.

2 The correspondence of ice classes specified in **1.2.2, Part I of the Rules** with those in the *Arctic Shipping Safety and Pollution Prevention Regulations* is as given in **Table 11.2.2-2**.

3 For the application of **Chapter 8, Part I of the Rules**, fore and aft perpendiculars are to be determined in the same manner as those of length L_f . The upper ice waterline specified in **1.2.1(23), Part I of the Rules** may be, in general, a broken line having different draughts fore and aft.

Table 11.2.2-1 The Correspondence of Ice Classes between the Rules and the *Finnish-Swedish Ice Class Rules*

Ice Class of the <i>Finnish-Swedish Ice Class Rules</i>	Ice Class of the Rules
IA Super	IA Super
IA	IA
IB	IB
IC	IC
II	ID No ice class

Table 11.2.2-2 The Correspondence of Ice Classes between the Rules and the *Arctic Shipping Safety and Pollution Prevention Regulations*

Ice Class of the <i>Arctic shipping Safety and Pollution Prevention Regulations</i>	Ice Class of the Rules
Type A	IA Super
Type B	IA
Type C	IB
Type D	IC
Type E	ID No ice class

11.3 Performance Standards (*Polar Code, Part I-B, 2.3*)

11.3.1 General

For “performance standards” specified in **1.3.1, Part I of the Rules**, a system previously accepted based on manufacturer certifications, classification society certifications and/or satisfactory service of existing systems may be acceptable for installation on new and existing ships if no performance or testing standards are accepted by the *IMO*.

11.5 Operational Assessment (*Polar Code, Part I-B, 2.1, 2.2*)

11.5.1 Operational Assessment

1 “Operational limitations” specified in **1.5.1, Part I of the Rules** is to be determined using systems, tools or analysis that evaluate the risks posed by the anticipated ice conditions to the ship, taking into account factors such as its ice class, seasonal changing of ice strength, icebreaker support, ice type, thickness and concentration. The ship's structural capacity to resist ice load and the ship's planned

operations are to be considered. The limitations are to be incorporated into an ice operational decision support system.

2 “Operational limitations” specified in **1.5.1, Part I of the Rules** is to be determined using an appropriate methodology, such methodologies exist, have been in use for a number of years and have been validated with service experience. Existing methodologies and other systems may be acceptable to the Society.

3 For the purpose of **1.5.1, Part I of the Rules**, operation in ice is to take into account the following:

- (1) Any operational limitations of the ship
- (2) Extended information on the ice operational methodology contained in the *PWOM*
- (3) The condition of the ship and ship’s systems
- (4) Historical weather/ice data
- (5) Weather/ice forecasts for the intended area of operation
- (6) Current conditions including visual ice observations, sea state, visibility
- (7) The judgment of qualified personnel

4 The “Operational Assessment” specified in **1.5.1, Part I of the Rules** is to be carried out by following steps:

- (1) identify relevant hazards specified in **1.4.1, Part I of the Rules** and other hazards based on a review of the intended operations;
- (2) develop a model, which is to refer to Appendix 3 of *MSC-MEPC.2/Circ.12 “Revised Guidelines for Formal Safety Assessment (FSA) for use in the IMO Rule-Making Process”* and standard *IEC/ISO 31010 “Risk management – Risk assessment techniques”*, to analyse risks considering:
 - (a) development of accident scenarios;
 - (b) probability of events in each accident scenario; and
 - (c) consequence of end states in each scenario;
- (3) assess risks and determine acceptability:
 - (a) estimate risk levels in accordance with the selected modelling approach; and
 - (b) assess whether risk levels are acceptable; and
- (4) in the event that risk levels determined in steps (1) to (3) are considered to be too high, identify current or develop new risk control options that aim to achieve one or more of the following:
 - (a) reduce the frequency of failures through better design, procedures, training, etc.;
 - (b) mitigate the effect of failures in order to prevent accidents;
 - (c) limit the circumstances in which failures may occur; or
 - (d) mitigate consequences of accidents; and
 - (e) incorporate risk control options for design, procedures, training and limitations, as applicable.

12 POLAR WATER OPERATIONAL MANUAL (PWOM)

12.3 Regulations

12.3.1 Polar Water Operational Manual (*Polar Code, Part I-B, 3.1*)

The Polar Water Operational Manual (*PWOM*) is intended to address all aspects of operations addressed by **Chapter 2, Part I of the Rules**. When appropriate information, procedures or plans exist elsewhere in a ship's documentation, the *PWOM* itself does not need to replicate this material, but may instead cross-reference the relevant reference document. A model table of contents is found in Appendix 2 of *IMO Res. MSC.385(94)* and *MEPC.264(68)* "International Code for Ships Operating in Polar Waters (*Polar Code*)" as amended. Not every section outlined below will be applicable to every polar ship. Many category *C* ships that undertake occasional or limit polar voyages will not need to have procedures for situations with a very low probability of occurrence. However, it may still be advisable to retain a common structure for the *PWOM* as a reminder that if assumptions change then the contents of the manual may also need to be updated. Noting an aspect as "not applicable" also indicates to the Society that this aspect has been considered and not merely omitted.

12.3.4 Procedures for Incidents in Polar Waters (*Polar Code, Part I-B, 3.3*)

For the purpose of **2.3.4, Part I of the Rules**, in developing the ship's contingency plans, ships are to consider damage control measures arrangements for emergency transfer of liquids and access to tanks and spaces during salvage operations.

12.3.6 Procedures for Icebreaker Assistance (*Polar Code, Part I-B, 3.2*)

With respect to navigation with icebreaker assistance specified in **2.3.6, Part I of the Rules**, the following are to be considered:

- (1) while approaching the starting point of the ice convoy to follow an icebreaker/icebreakers or in the case of escorting by icebreaker of one ship to the point of meeting with the icebreaker, ships are to establish radio communication on the VHF channel 16 and act in compliance with the icebreaker's instructions;
- (2) the icebreaker rendering the icebreaker assistance of ship ice convoy is to command ships in the ice convoy;
- (3) position of a ship in the ice convoy is to be determined by the icebreaker rendering the assistance;
- (4) ship within the ice convoy, in accordance with the instructions of the icebreaker rendering the assistance, is to establish communication with the icebreaker by VHF channel indicated by the icebreaker;
- (5) the ship, while navigating in the ice convoy, is to ensure compliance with the instructions of the icebreaker;
- (6) position in the ice convoy, speed and distance to a ship ahead is to be as instructed by the icebreaker;
- (7) the ship is to immediately notify the icebreaker of any difficulties to maintain the position within the ice convoy, speed and/or distance to any other ship in the ice convoy; and
- (8) the ship is to immediately report to the icebreaker of any damage.

I3 SHIP STRUCTURE

I3.3 Regulations (with reference to *Polar Code, Part I-B, 4*)

I3.3.1 Materials of Structures

1 For the purpose of **3.3.1, Part I of the Rules**, “other standards offering an equivalent level of safety” are to comply with the following -2 to -7 below.

2 “Other standards offering an equivalent level of safety” are to be determined by the following.

- (1) The basic approach for considering equivalency for categories *A* and *B* ships can be the same for both new and existing ships.
- (2) For ice classes under category *C*, additional information on comparisons of strengthening levels is available for the guidance.
- (3) The responsibility for generating the equivalency request and supporting information required is to rest with the owner/operator.
- (4) Review/approval of any equivalency request is to be undertaken by the Society.
- (5) If there is not full and direct compliance, then an equivalent level of risk are to be as deemed appropriate by the Society.
- (6) An increase in the probability of an event can be balanced by a reduction in its consequences. Alternatively, a reduction in probability could potentially allow acceptance of more serious consequences. Using a hull area example, a local shortfall in strength level or material grade could be accepted if the internal compartment is a void space, for which local damage will not put the overall safety of the ship at risk or lead to any release of pollutants.

3 The scope of a simplified equivalency assessment (referring to paragraphs -5(1) to (3) below) is expected to be limited to materials selection, structural strength of the hull and propulsion machinery.

4 For existing ships, service experience can assist in risk assessment. As an example, for an existing ship with a record of polar ice operations a shortfall in the extent of the ice belt (hull areas) may be acceptable if there is no record of damage to the deficient area; i.e. a ship that would generally meet *PC5* requirements but in limited areas is only *PC7* could still be considered as a category *A, PC5* ship. In all such cases, the ship’s documentation is to make clear the nature and scope of any deficiencies.

5 The assessment procedure for equivalency

- (1) select the target Polar Class for equivalency;
- (2) compare materials used in the design with minimum requirements of the Polar Class; identify any shortfalls; and
- (3) compare strength levels of hull and machinery components design with requirements of the Polar Class; quantify levels of compliance.

6 Where gaps in compliance are identified in steps -5(1) to (3) above, additional steps are to be necessary to demonstrate equivalency, as outlined below:

- (1) identify any risk mitigation measures incorporated in the design of the ship;
- (2) where applicable, provide documentation of service experience of existing ships, in conditions relevant to the target ice class for equivalency; and
- (3) undertake an assessment, taking into account information from steps -5(1) to (3) and -6(1) and (2), as applicable, and on the principles outlined in paragraphs -2 to -5 above.

7 Documentation provided with an application for equivalency is to identify each stage that has been undertaken, and sufficient supporting information to validate assessments.

I3.3.2 Hull Structures

“Other standards offering an equivalent level of safety” specified in **3.3.2(1)(b)** and **(2)(b), Part I of the Rules** are to comply with the requirements in **13.3.1**.

16 MACHINERY INSTALLATIONS

16.3 Regulations (Related to *Polar Code*, Part I-B, 7)

16.3.1 General

In applying **6.3.1(3), Part I of the Rules**, the seawater supplies for machinery systems “designed to prevent ingestion of ice” are to be in accordance with *MSC/Circ.504*.

16.3.2 Ships intended to Operate in Low Air Temperatures

The wording “other standards offering an equivalent level of safety” specified in **6.3.2(3)(b), Part I of the Rules** means those in accordance with **I3.3.1**.

16.3.3 Ice Strengthened Ships

The wording “other standards offering an equivalent level of safety” specified in **(1)(b)** and **(2)(b)** of **6.3.3(3), Part I of the Rules** means those in accordance with **I3.3.1**.

I7 FIRE SAFETY/PROTECTION

I7.3 Regulations

I7.3.3 Ships Intended to Operate in Low Air Temperatures

The wording “acceptable to the Society” specified in **7.3.3(2), Part I of the Rules** means those as follows:

- (1) Materials taking into account **Chapter 2, Annex 1, Part I of the Rules** “**Special Requirements for the Materials, Hull Structures, Equipment and Machinery of Polar Class Ships**”; or
- (2) Materials taking into account other standards offering an equivalent level of safety to those specified in **(1)** above based on the polar service temperature.

I8 ICE CLASS SHIPS

18.1 General

18.1.1 Application

1 For ice class ships trading in the Northern Baltic in the winter under the control of the regulation “*Finnish-Swedish Ice Class Rules*”, The “*Guidelines for the Application of the Finnish-Swedish Ice Class Rules*” may be applied. Regard needs to be paid to the following as extracted from said guidelines.

- (1) The Finnish and Swedish administrations provide icebreaker assistance to ships bound for ports in these two countries during the winter season. Depending on the ice conditions, restrictions are enforced with regard to the size and ice class of ships entitled to icebreaker assistance.
- (2) It should not be assumed that mere compliance with these regulations guarantees a certain degree of capability to advance in ice without icebreaker assistance, or to withstand heavy ice compression in the open sea, where the ice field may move due to high wind speeds.
- (3) It should be noted that the ice-going capacity of small ships may be somewhat lower than that of larger ships in the same ice class.
- (4) Notch towing is often the most efficient way of assisting ships of moderate size (with a displacement not exceeding 30,000 tons).
- (5) Ice class ships with a bulb protruding more than 2.5m forward of the forward perpendicular, ice class ships with too blunt of a bow shape and ice class ships with an ice knife fitted above the bulb are often difficult for notch towing.
- (6) If the bow is too high in ballast condition, the ship could be trimmed to lower the bow.
- (7) An ice strengthened ship is assumed to operate in open sea conditions corresponding to a level ice thickness not exceeding h_0 . The design ice load height (h) of the area actually under ice pressure at any particular point of time is, however, assumed to be only a fraction of the ice thickness. The values for h_0 and h are given in [Table I8.1.1-1](#).

Table I8.1.1-1

Ice Class	h_0 (m)	h (m)
<i>IA Super</i>	1.00	0.35
<i>IA</i>	0.80	0.30
<i>IB</i>	0.60	0.25
<i>IC</i>	0.40	0.22

2 For the ice class ship to be entitled to an ice notation, calculation sheet of main propulsion engine output is to be submitted in addition to drawings and data for reference in [2.1.3-1\(2\)](#), [Part D of the Rules](#).

18.3 Hull Structures and Equipment

18.3.2 General Requirements for Frames

1 With respect to the provisions of [8.3.2-2](#), [Part I of the Rules](#), where longitudinal frames are running through supporting structures such as web frames or transverse bulkheads, brackets are to be fitted on both sides of the supporting structures. (See [Fig. I8.3.2-1](#)) Where transverse frames are running through supporting structures such as deck or ice stringers within the ice belt, it is recommended that brackets are also fitted on the above side of the supporting structures. (See [Fig. I8.3.2-2](#)) The standard arm length of a bracket is not to be less than the depth of a frame web.

2 For *IA Super* and *IA* ice class ships, it is recommended that the distance d between the lower edge of the collar plate and the surface of shell plating at the point where a frame is running through the supporting structure in the ice strengthening area be 0 (see [Fig. I8.3.2-3](#)).

3 With respect to 8.3.2-3(4), Part I of the Rules, if either the angle of the frame inclination or the principal axis of the frame (without attached plating) deviates more than 15° from normal to the plating, support against tripping is required.

Fig. I8.3.2-1 Brackets for Longitudinal Side Frames

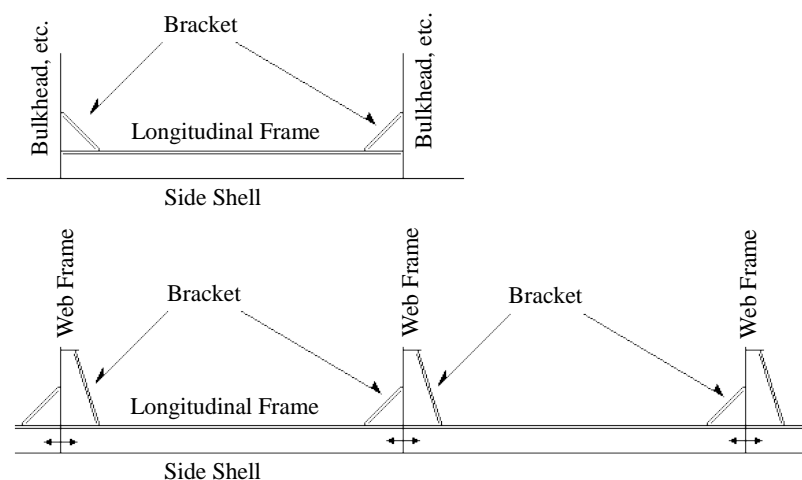
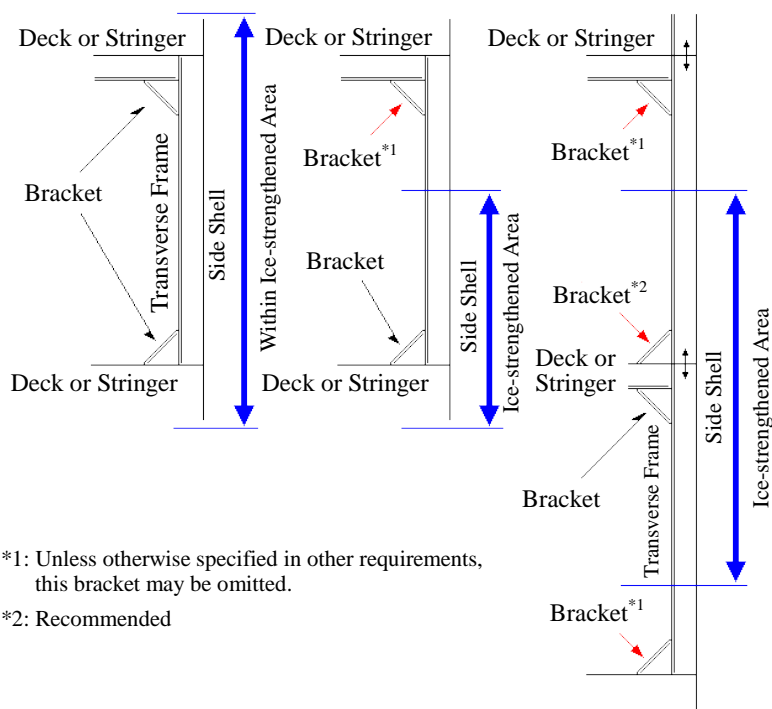
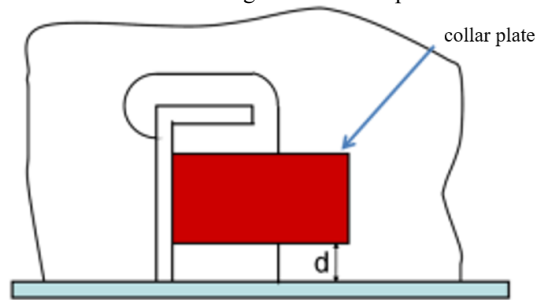

Fig. I8.3.2-2 Brackets for Transverse Side Frames



*1: Unless otherwise specified in other requirements, this bracket may be omitted.

*2: Recommended

Fig. I8.3.2-3 Distance d between the lower edge of the collar plate and the surface of shell plating

18.3.4 Longitudinal Frames

1 With respect to the provisions of [8.3.4, Part I of the Rules](#), vertical extension of ice strengthening of longitudinal framing may be limited to longitudinal frames within the ice belt specified in [8.3.1-1, Part I of the Rules](#) and those just above and below the edge of the ice belt, except where deemed necessary by the Society. In this case, the spacing of longitudinal frames just above and below the edge of the ice belt is to be the same as the frame spacing in the ice belt. Notwithstanding the above, the longitudinal frames just above and below the edges of the ice belt are closer than 50% of s to the upper and lower edges of the ice belt respectively, where s is the frame spacing in the ice belt s is to be extended to the second longitudinal frame above and below the ice belt.

2 With respect to the provisions of [8.3.4-1, Part I of the Rules](#), boundary condition factor m for frames in conditions deviating from those of continuous beam is to be determined in accordance with the following:

- (1) For conditions deemed as those fixed at both ends: $m = 12$
- (2) For conditions deemed as those simple supported at both ends: $m = 8$
- (3) For conditions other than (1) or (2), boundary condition factor m is to be determined by calculation using simple beam theory, but in no case that m is not to be greater than 13.3.

18.3.5 Ice Stringers

With respect to the provisions of [8.3.5, Part I of the Rules](#), boundary condition factor m for ice stringers in conditions deviating from those of continuous beam is to be determined in accordance with [I8.3.4-2](#).

18.3.6 Web Frames

With respect to the provisions of [8.3.6-4, Part I of the Rules](#), when the direct analysis is not based on beam theory, the allowable shear stress is to be τ_y .

18.3.8 Arrangements for Towing

The wording "special consideration" specified in [8.3.8, Part I of the Rules](#) refers to the following:

- (1) The towing arrangement uses a thick wire which is split into two slightly thinner wires as shown in [Fig.I8.3.8-1](#).
- (2) Two fairleads are to be fitted symmetrically off the centreline with one bollard each.
- (3) The distance of the bollards from the centreline is approximately 3 m . The bollards are to be aligned with the fairleads allowing the towlines to be fastened straight onto them.
- (4) Bollards or other means for securing towlines are structurally designed to withstand the breaking force of the towline of the ship.

Fig. 18.3.8-1 The Typical Towing Arrangement

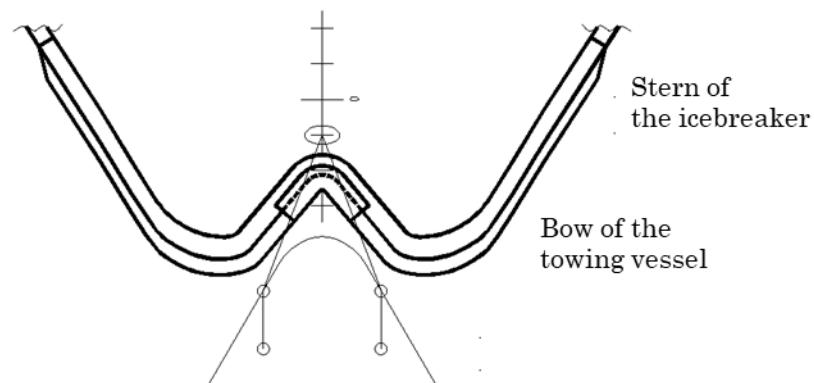

18.3.9 Stern

1 The clearance between the propeller blade tip and the stern frame is not to be less than $0.5m$ to prevent high loads from occurring on the blade tip. The ice clearance between the propeller blade tip and the bottom of the level ice sheet is to be positive when the level ice thickness is taken as specified in [Table 18.1](#). (See [Fig. 18.3.9-1](#))

2 A wide transom stern extending below the *UIWL* will seriously impede the capability of the ship to astern in ice. Therefore, a transom stern is not to be extended below the *UIWL* if this can be avoided. If unavoidable, the part of the transom stern below the *UIWL* is to be kept as narrow as possible. The part of a transom stern situated within the ice belt is to be strengthened at least as for the midbody region.

Fig. I8.3.9-1 The Clearance between the Stern Frame and the Propeller (left) and the Ice Sheet and the Propeller when the Ship is at *LIWL* (right)

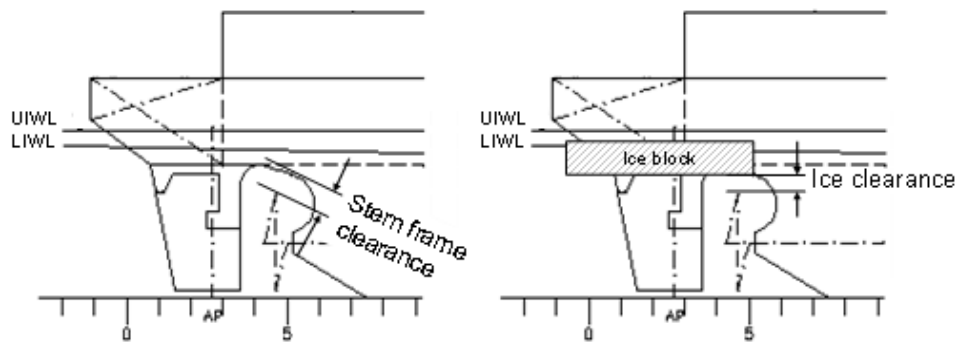

18.3.10 Bilge Keel

The wording “special consideration” specified in **8.3.10, Part I of the Rules** refers to the following:

- (1) The connection of bilge keels to the hull is to be so designed that the risk of damage to the hull, in case a bilge keel is ripped off, is minimized.
- (2) Bilge keels are recommended to be constructed as shown in **Fig. I8.3.10-1**.
- (3) It is recommended that bilge keels are cut up into several shorter independent lengths.

Fig. I8.3.10-1 An Example of Bilge Keel Construction

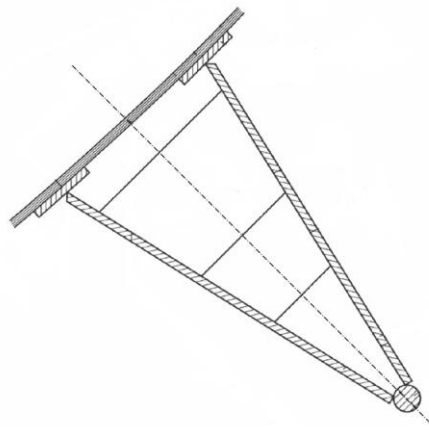

18.4 Fundamental Requirements of Machinery

18.4.3 Rudders and Steering Arrangements

The wording “Ice knife” specified in **8.4.3-3, Part I of the Rules** refers to the following and special consideration is to be given to the strength and proper shape of the ice knife.

- (1) The ice knife bottom is to be below water in all draughts
- (2) Where the ship is not intended to go astern in ice at some draught, a smaller ice knife may be used.
- (3) An ice knife is recommended to be installed on all ships with ice class *IA Super* or *IA*.

Fig. I8.4.3-1 An Example of an Adequate Ice Knife Design

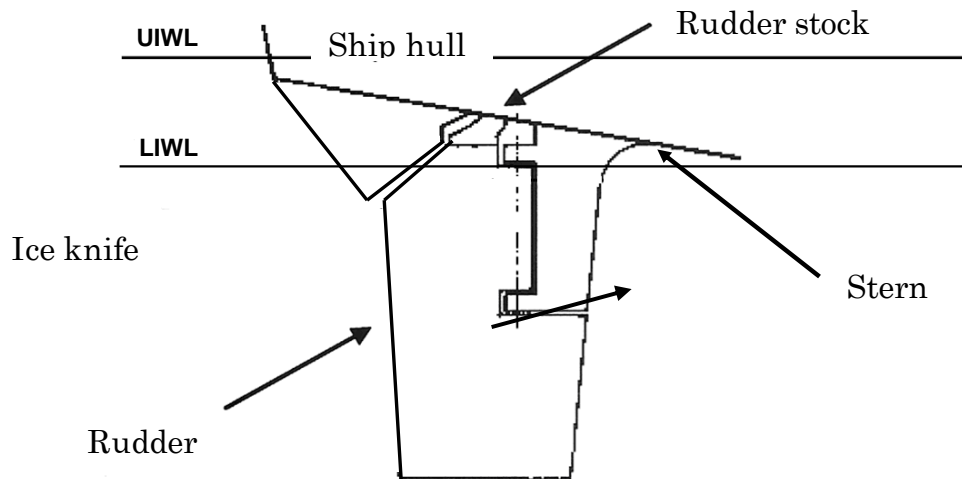

18.6 Design of Propellers and Propulsion Shafting Systems (Ice Classes IA Super, IA, IB and IC)

18.6.3 Propeller Bossing and CP Mechanism

Where the propeller is force-fitted on the propeller shaft without key, the lower limit of pull-up length is to be determined according to 7.3.1-1, Part D of the Rules, substituting F'_V given by following formula for F_V and the thrust T is to be determined according to maximum thrust T_r given by 8.5.7, Part I of the Rules:

$$F'_V = F_V + 4.46 \frac{Q_{max}}{R_0} \times 10^5 \text{ (N)}$$

where:

Q_{max} : Maximum propeller ice torque (kNm) specified in 8.5.8, Part I of the Rules.

R_0 : Radius (mm) of the propeller shaft cone part at the mid-length

F_V : Tangential force (N) acting on contact surface specified in 7.3.1-1, Part D of the Rules.

18.6.5 Azimuthing Main Propulsors

The value of "A" specified in 8.6.5(2)(b), Part I of the Rules according to load cases given in Table I8.25, Part I of the Rules is to comply with following (1) to (3) respectively:

- (1) In the case of T1c (non-symmetric longitudinal ice impact on nozzle), the value of "A" is the nozzle thickness (H_{nz}) \times the contact height (H_{ice}).
- (2) In the case of T3a (symmetric lateral ice impact on thruster body), the value of "A" is the area of the circle whose diameter is equal to the pod body diameter.
- (3) In the case of T3b (non-symmetric lateral ice impact on thruster body or nozzle), the followings are to apply.
 - (a) In the case of ice impact on thruster body, the value of "A" is the area of the circle whose diameter is equal to the pod body diameter.
 - (b) In the case of ice impact on nozzle, the value of "A" is the area of the circle whose diameter is equal to the nozzle length (L_{nz}).

18.7 Alternative Designs

18.7.1 Alternative Design

The examination specified in 8.7, Part I of the Rules, may be according to the following (1) to (3).

- (1) The study has to be based on ice conditions given for the different ice classes specified in 8.5, Part I of the Rules. It has to include both fatigue and maximum load design calculations and fulfill the pyramid strength principle, as given in 8.5.1, Part I of the Rules.

(2) Loading

Loads on propeller blades and propulsion systems are to be based on acceptable estimations of hydrodynamic and ice loads.

(3) Design levels

- (a) Analysis is to confirm that all components transmitting random (occasional) forces, excluding propeller blade, are not subjected to stress levels in excess of the yield stress of the component material, within a reasonable safety margin.
- (b) Cumulative fatigue damage calculations are to give reasonable safety factors. Due account is to be taken of material properties, stress raisers, and fatigue enhancements.
- (c) Vibration analysis is to be performed and demonstrate that overall dynamic systems are free of the harmful torsional resonances resulting from propeller/ice interaction.